

# AUTOMATED WATER ANALYSIS

## APPLICATIONS OF CONTINUOUS-FLOW ANALYZERS

In laboratories around the world, the Bran+Luebbe analyzers measure all types of water - quickly, accurately and automatically.

### HIGH SPEED

Up to 120 samples per hour, with simultaneous measurement of multiple parameters:

- ☐ 250 results per hour on a 5-channel AutoAnalyzer 3 for nutrients in seawater
- ☐ 400 results per hour on a 4-channel QuAAtro for drinking water

### LOW DETECTION LIMIT

The segmented-flow technology used in the AutoAnalyzer allows complete reaction and long measurement time. Combined with the high-resolution detector this results in the ability to measure very low concentrations.

- ☐ Nitrate in drinking water: 70 ng/L as N
- ☐ Phosphate in seawater: 95 ng/L as P
- ☐ Silicate in boiler water: 130 ng/L as SiO<sub>2</sub>
- ☐ Phenol in tap water: 0.5 µg/L

### HIGH REPRODUCIBILITY

Electronically controlled air injection and sophisticated peak-reading algorithms provide low Relative Standard Deviation.

- ☐ 5 mg/L Ammonia in waste water at 100 samples per hour: 0.3% R.S.D.
- ☐ 200 µg/L Cyanide in waste water with on-line distillation: 0.4% R.S.D.



Bran+Luebbe applications are constantly being developed in our laboratories.

### ALL TYPES OF SAMPLE

- ☐ Drinking water
- ☐ Waste water
- ☐ River water
- ☐ Ground water
- ☐ Sea water
- ☐ Ultra-pure water

# AUTOMATING SAMPLE PREPARATION AND ANALYSIS

## DIALYSIS

Dialyzers automatically remove interference from dirty or colored samples such as waste water.

A dialysis membrane with pore size about 4 nm allows small ions and molecules to pass through to the measuring stream but separates solids, colloids, proteins, humic acids and other large molecules.

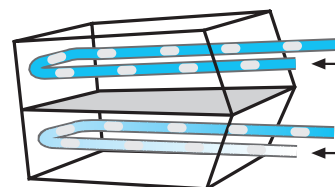

## DISTILLATION

Automated on-line distillation is used in the ISO standard methods for phenol and cyanide, and also for fluoride, ammonia and other analytes to purify the sample and remove interference.

The sample is heated to 150°C in a special heating coil, then the vapour is separated from the residue in a separation column.

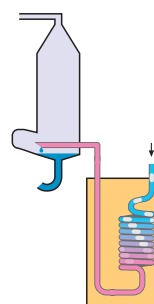

## HEATING UP TO 120°C

For reactions such as the hydrolysis of inorganic polyphosphates. The heating coil is available in different sizes to automate the specific heating requirements of each chemistry.

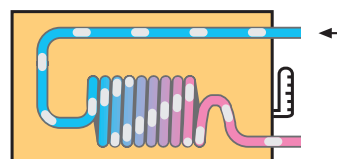

## SOLVENT EXTRACTION

Used in the ISO standard methods for anionic surfactants and phenol index.

Aqueous and organic liquids are pumped through the same tubing and extraction quickly takes place in the small segments formed. The phases are then separated by gravity and the wanted phase is pumped to the next stage of the analysis.

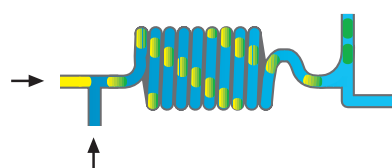

## REACTION TIME UP TO 20 MINUTES

Slow reactions such as the determination of ammonia and phosphate can proceed to completion. This ensures maximum sensitivity and lowest detection limit.

Many different coils are available for different delay times and special applications.

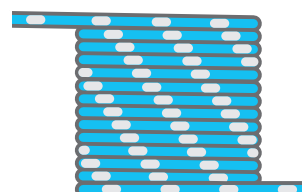

## UV DIGESTION

On-line UV digestion is used for the fully automatic determination of Total N, Total P and DOC.

The sample, with an oxidising reagent if necessary, is pumped through a quartz coil surrounding a low-wave-length UV lamp.

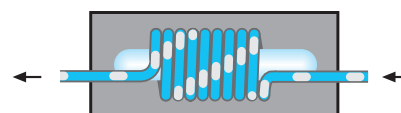

# SOLUTIONS TO LABORATORY NEEDS



*2-channel AutoAnalyzer 3 in a water testing laboratory.*

## AUTOMATIC DIGESTION

### LAB NEED

Total N and P determinations require pre-digestion, a time-consuming manual procedure.

### SOLUTION

On-line UV digestion methods such as the ISO standard procedure for Total P digest and analyze samples automatically.

UV digestion is also used in the EPA and ISO standard methods for total cyanide, to break down complex cyanides to  $CN^-$  ions.

## ON-LINE DISTILLATION

### LAB NEED

Samples for tests like phenol, cyanide and fluoride must be distilled before analysis to eliminate interference.

### SOLUTION

The on-line distillation module automates distillation for continuous-flow analysis.

EPA and ISO standard methods are available.

## FEW SAMPLES, MANY DIFFERENT TESTS

### LAB NEED

Up to 50 samples per day have to be analyzed for several different parameters, but funds do not allow the purchase of a large multi-channel system.

### SOLUTION

Multitest methods can analyze many different parameters without the need to buy separate hardware for each test.

Only the reagents and colorimeter filter need to be changed between tests. Tests needed only occasionally can be run at low cost and effort.

# SYSTEMS FOR LARGE AND SMALL LABORATORIES

Different laboratories have different needs. With its modular design, multi-channel configuration and choice of samplers, the AutoAnalyzer is easily adaptable to the needs of different labs. When requirements change or workloads increase, the analyzer can easily be adapted or expanded.

## FOR LABS REQUIRING ECONOMY AND HIGH FLEXIBILITY

A 1-channel or 2-channel AutoAnalyzer 3 with MT7 or MT15 multitest brings the accuracy of segmented-flow analyzers to 14 different tests. EPA and ISO methods are available.

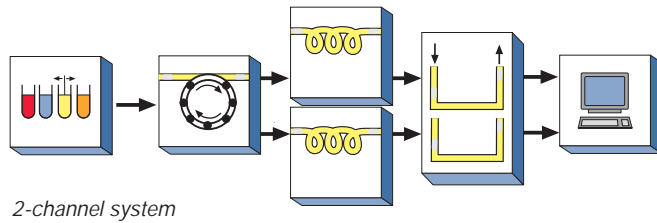
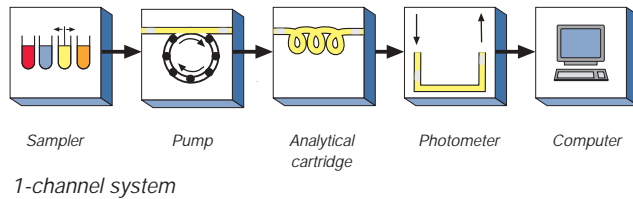

### Analysis rate:

50 - 60 samples per hour. See the MT7 table for details of concentration ranges

- |                                     |  |
|-------------------------------------|--|
| <input type="checkbox"/> Alkalinity | <input type="checkbox"/> Nitrogen, total (Kjeldahl or persulfate digest)   |
| <input type="checkbox"/> Ammonia    | <input type="checkbox"/> Phosphate   |
| <input type="checkbox"/> Boron      | <input type="checkbox"/> Phosphorus, total (Kjeldahl or persulfate digest) |
| <input type="checkbox"/> Calcium    | <input type="checkbox"/> Silicate  |
| <input type="checkbox"/> Chloride   | <input type="checkbox"/> Sulfide   |
| <input type="checkbox"/> Iodide     |  |
| <input type="checkbox"/> Iron       |  |
| <input type="checkbox"/> Nitrate    |  |
| <input type="checkbox"/> Nitrite    |  |



## ECOANALYZER

Economical system with the advantages of segmented-flow analysis at an economical price.



## QUAATRO

Up to 120 samples per hour, with innovative automation before, during and after the analysis.

## FOR LABS WITH A HIGH WORKLOAD

A system with dedicated methods can run up to 8 different tests at the same time, allowing hundreds of samples to be processed in one day.

An example of a multi-channel system is the 5-channel analyzer for nutrients in seawater.

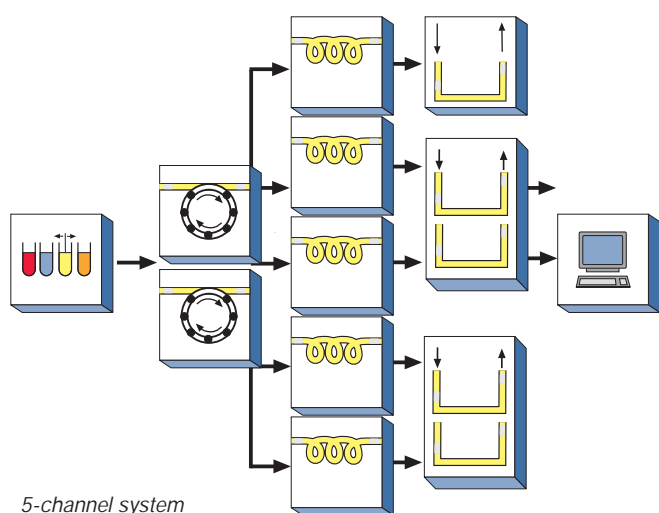

## FOR LABS WITH A WIDE VARIETY OF SAMPLES

The routine tests opposite can be extended with further tests simply by adding extra analytical cartridges such as these methods for contaminated water:

### ANIONIC SURFACTANTS

- Range: 0-0.5 to 0-5 mg/L or higher as SDS
- Detection limit: 10 µg/L

### CYANIDE (FREE OR TOTAL)

- Range: 0-60 to 0-600 µg/L or higher
- Detection limit: 0.2 µg/L

### PHENOL

- Range: 0-150 to 0-13000 µg/L or higher
- Detection limit: 0.2 µg/L

## SEA WATER

These state-of-the-art methods, developed in conjunction with the University of Hamburg, the Netherlands Institute for Oceanographic Research (NIOZ) and the Ocean University of Qingdao in China offer the best performance available for seawater analysis. They can be augmented with fully automated methods for Total N and P with on-line digestion.

Ammonia	0.025	µMol
Nitrate	0.005	µMol
Nitrite	0.005	µMol
Phosphate	0.0014	µMol
Silicate	0.015	µMol



## AUTOANALYZER 3

Lowest detection limit and widest range of applications.



# MULTI-RANGE MULTI-TEST METHODS

## MEDIUM AND HIGH CONCENTRATIONS

For drinking water, river water, ground water and waste water: these multi-range methods incorporate a dialyser for the high range to eliminate interference from suspended solids, colloids, dissolved protein and other large or coloured compounds in waste water. A heating bath and 7-minute reaction time ensure complete reaction and maximum sensitivity on all methods. Automatic range changeover is possible with the range-switch option. All the parameters below can be analyzed with one MT7 multitest cartridge: only the reagents and the colorimeter filter have to be changed between tests. The high range can easily be extended by a factor of 2 or 3 by changing the sample pump tube.



*Built-in dialyzers eliminate interference from dirty water samples.*

PARAMETER	LOW RANGES	HIGH RANGES (WITH DIALIZER)
Alkalinity	0-300 to 0-700 mg/L as CaCO <sub>3</sub>	-
Ammonia (DIN)	0-0.25 to 0-7 mg/L	0-2.5 to 0-35 mg/L as N
Boron	0-1 to 0-15 mg/L	0-5 to 0-70 mg/L
Calcium	-	0-12 to 0-120 mg/L
Chloride	0-10 to 0-150 mg/L	0-25 to 0-350 mg/L
Iron	0-1 to 0-10 mg/L	0-10 to 0-120 mg/L
Nitrate	0-0.25 to 0-3 mg/L	0-0.9 to 0-15 mg/L as N
Nitrite	0-0.25 to 0-3 mg/L	0-0.9 to 0-15 mg/L as N
Nitrogen, total (Kjeldahl or persulfate digest)	0-0.6 to 0-9 mg/L	0-2.5 to 0-35 mg/L
Phosphate	0-1 to 0-10 mg/L	0-6 to 0-70 mg/L as P
Phosphorus, total (Kjeldahl or persulfate digest)	0-1.7 to 0-9 mg/L	0-6 to 0-70 mg/L as P
Silicate	0-4 to 0-65 mg/L	0-25 to 0-350 mg/L as SiO <sub>2</sub>
Sulfide	0-0.5 to 0-6 mg/L	0-2 to 0-15 mg/L as S

*Methods and ranges with MT7 multitest cartridge on the AutoAnalyzer.*

## LOW AND MEDIUM CONCENTRATIONS AND SEAWATER

All these parameters can be analyzed with MT18 and MT19 multitest cartridges in an economical 2-channel system.

These methods were specially designed for low detection limit and wide range. A heating bath and 5-minute reaction time ensure stability and maximum sensitivity. Automatic changeover between ranges is possible with the range-switch option.



*Bran+Luebbe analyzers are used world-wide to check the quality and purity of drinking water.*

PARAMETER	LOW RANGES	HIGH RANGES	DETECTION LIMIT
Ammonia	0-42 to 0-1500 µg/L	0-0.35 to 0-15 mg/L as N	0.6 µg/L
Nitrite	0-4.2 to 0-400 µg/L	0-84 to 0-3500 µg/L as N	0.03 µg/L
Nitrate	0-9 to 0-700 µg/L	0-70 to 0-3000 µg/L as N	0.1 µg/L
Nitrogen, total (persulfate digests)	0-9 to 0-700 µg/L	0-70 to 0-3000 µg/L	0.4 µg/L
Phosphate	0-15 to 0-1500 µg/L	0-0.15 to 0-5 mg/L as P	0.2 µg/L
Phosphorus, total (persulfate digests)	0-15 to 0-1500 µg/L	0-0.15 to 0-5 mg/L	0.5 µg/L
Silicate	0-90 to 0-7500 µg/L	0-1.5 to 0-50 mg/L as SiO <sub>2</sub>	0.7 µg/L

*Methods and ranges with MT18 and MT19 multitest cartridges.*

# METHODS

	US EPA APPROVED METHOD	ISO APPROVED METHOD*	AUTOANALYZER	QUAATRO
Acidity			•	
Alkalinity	•		•	•
Aluminium Al		•	•	•
Ammonia NH <sub>3</sub>	•	•	•	•
Anionic surfactants (MBAS)		•	•	
Carbon (DOC)			•	
Chloride Cl <sup>-</sup>	•	•	•	•
Chlorine Cl <sub>2</sub>			•	
Chromium		•	•	•
C.O.D.	•		•	
Cyanide CN (free or total)	•	•	•	
Fluoride F	•		•	
Hardness (Ca, Mg)	•		•	•
Iron Fe			•	•
Manganese Mn			•	•
Nitrate NO <sub>3</sub>	•	•	•	•
Nitrite NO <sub>2</sub>	•	•	•	•
Nitrogen, total (Kjeldahl digests)	•		•	•
Nitrogen, total (K <sub>2</sub> S <sub>2</sub> O <sub>8</sub> digests)			•	•
Nitrogen, total (automated UV digestion)			•	
Phenol C <sub>6</sub> H <sub>5</sub> OH	•		•	
Phosphate PO <sub>4</sub>	•		•	•
Phosphorus, total (Kjeldahl digests)	•		•	•
Phosphorus, total (K <sub>2</sub> S <sub>2</sub> O <sub>8</sub> digests)		•	•	•
Phosphorus, total (automated UV digestion)		•	•	
Potassium K			•	•
Silicate SiO <sub>2</sub>	•	•	•	•
Sodium Na			•	•
Sulfate SO <sub>4</sub>			•	
Sulfide S			•	•
Uranium U			•	
Urea CHONH <sub>2</sub>			•	

\* Some pending; new methods planned.