

Wind Monitor Series

R.M Young's 05103, 05103-45, 05106, 05305



RM Young's Wind Monitors are light-weight instruments that measure wind speed and direction. Their design emphasizes simplicity and lightweight construction. The Wind Monitors are made out of rigid UV-stabilized thermoplastic with stainless steel and anodized aluminum fittings. The thermoplastic material resists corrosion from sea air environments and atmospheric pollutants. The Wind Monitors use stainless steel precision-grade ball bearings for the propeller shaft and vertical shaft bearings. Cabled for use with our dataloggers, the Wind Monitors are compatible with all of our contemporary dataloggers and many of our retired dataloggers (e.g., CR10X, CR510, CR23X).

Wind Speed

The wind speed sensor for all the Wind Monitors is a helicoid-shaped, four-blade propeller. Rotation of the propeller produce an ac sine wave that has a frequency directly proportional to wind speed. The ac signal is induced in a transducer coil by a six-pole magnet mounted on the propeller shaft. The coil resides on the non-rotating central portion of the main mounting assembly, eliminating the need for slip rings and brushes.

Wind Direction

All of the Wind Monitors use a potentiometer to measure wind direction. The datalogger applies a known precision excitation voltage to the potentiometer element. The output signal is an analog voltage directly proportional to the azimuth angle.

Model Descriptions

05103 Wind Monitor

The 05103 Wind Monitor is a sturdy instrument for measuring wind speed and direction in harsh environments. Its simplicity and corrosion-resistant construction make it ideal for a wide range of wind measuring applications.

05103-45 Alpine Wind Monitor

The 05103-45 Wind Monitor is a rugged instrument designed for harsh alpine conditions. To discourage ice-buildup, the sensor's housing is black and covered with an ice-resistant coating.

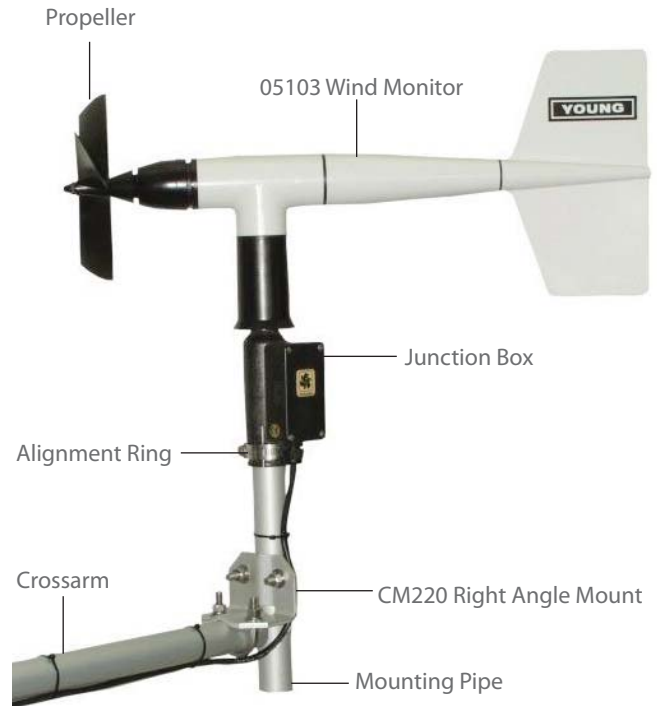

This 05103 Wind Monitor is attached to a crossarm via a CM220 Right Angle Mount and a mounting pipe (shipped with the sensor).



The 05103-45 is designed to prevent ice buildup allowing the sensor to provide accurate measurements in harsh alpine conditions.

Model Descriptions (continued)

05106 Wind Monitor-MA

The 05106 Wind Monitor-MA is a robust instrument designed for offshore and marine applications. It features waterproof bearing lubricant and a sealed, heavy-duty cable pigtail instead of the standard junction box.

05305 Wind Monitor-AQ

The 05305 Wind Monitor-AQ is a high performance wind speed and direction sensor designed specifically for air quality measurements. It provides a lower starting threshold, faster response, and higher accuracy than the other wind monitors. However, to achieve the superior performance, the 05305 is less ruggedly constructed.

The Wind Monitor-AQ meets or exceeds the requirements published by the following regulatory agencies:

- **U.S. Environmental Protection Agency**— Ambient Monitoring Guidelines for Prevention of Significant Deterioration (PSD) and On-Site Meteorological Instrumentation Requirements to Characterize Diffusion from Point Sources
- **U.S. Nuclear Regulatory Agency**—NRC Regulatory Guide 1.23 Meteorological Programs in Support of Nuclear Power Plants
- **American Nuclear Society**—Standard for Determining Meteorological Information at Nuclear Power Plants

Mounting

The Wind Monitors can be attached to a CM202, CM204, or CM206 crossarm via a 17953 NU-RAIL fitting or CM220 Right Angle Mounting Bracket. Alternatively, the Wind Monitors can be attached to the top of our stainless-steel tripods via the CM216 Sensor Mounting Kit.

Wind Profile Studies

Wind profile studies measure many wind sensors. For these applications, the LLAC4 4-Channel Low Level AC Conversion Module can be used to increase the number of Wind Monitors measured by one datalogger. The LLAC4 allows datalogger control ports to read the wind speed sensor's ac signals instead of using pulse channels. Dataloggers compatible with the LLAC4 are the CR200-series (ac signal ≤ 1 kHz only), CR800, CR850, CR1000, CR3000, and CR5000.



This 05106 Wind Monitor-MA is attached to a crossarm via a 17953 NU-RAIL fitting and a mounting pipe (shipped with the sensor).



An innovative method of discouraging interference from birds was used at a station at St. Peter and St. Paul Rocks (Brazil). Photo courtesy Dr. Silvia L. Garzoli (Director of the Physical Oceanography Division of the Atlantic Oceanographic and Meteorological Laboratory of NOAA).

Ordering Information

Wind Monitors

- 05103-L** Wind Monitor with user-specified cable length. Specify the cable length, in feet, after the L. For example, 05103-L13 orders a 13 ft lead length. A cable termination option is required (see below).
- 05103-45-L** Wind Monitor, Alpine Version with user-specified cable length. Specify the cable length, in feet, after the L. For example, 05103-45-L13 orders a 13 ft lead length. A cable termination option is required (see below).
- 05106-L** Wind Monitor-MA for marine applications with user-specified cable length. Specify the cable length, in feet, after the L. For example, 05106-L13 orders a 13 ft lead length. A cable termination option is required (see below).
- 05305-L** Wind Monitor-AQ for air quality applications with user-specified cable length. Specify the cable length, in feet, after the L. For example, 05305-L13 orders a 13 ft lead length. A cable termination option is required (see below).

Cable Termination Options (choose one)

- PT** Cable terminates in stripped and tinned leads for direct connection to a datalogger's terminals.
- PW** Cable terminates in connector for attachment to a prewired enclosure.

Mounts

- 17953** 1-inch x 1-inch NU-RAIL Fitting for attaching the Wind Monitor to a crossarm, such as a CM202, CM204, or CM206 crossarm.
- CM220** Right Angle Mounting Bracket for attaching the Wind Monitor to a crossarm, such as a CM202, CM204, or CM206 crossarm.
- CM216** Sensor Mounting Kit for attaching sensor to atop a CM110, CM115, or CM120 stainless-steel tripod.

Wind Profile Accessory

- LLAC4** 4-Channel Low-Level AC Conversion Module



The 05305 Wind Monitor-AQ provides high accuracy measurements, typically for air quality applications.



The LLAC4 is often used to measure up to four Wind Monitors, and is especially useful for wind profiling applications.

Recommended Cable Lengths

CM6	CM10	CM110	CM115	CM120	UT10	UT20	UT30
10 ft	13 ft	13 ft	19 ft	24 ft	13 ft	24 ft	34 ft

These lead lengths assume the sensor is mounted atop the tripod/tower via a CM202 crossarm.

Specifications

	05103 Wind Monitor¹	05103-45 Wind Monitor-Alpine¹	05106 Wind Monitor-MA¹	05305 Wind Monitor-AQ¹
<i>Wind Speed</i>				
Range	0 to 224 mph (0 to 100 m s ⁻¹)	0 to 224 mph (0 to 100 m s ⁻¹)	0 to 224 mph (0 to 100 m s ⁻¹)	0 to 112 mph (0 to 50 m s ⁻¹)
Accuracy	±0.6 mph (±0.3 m s ⁻¹) or 1% of reading	±0.6 mph (±0.3 m s ⁻¹) or 1% of reading	±0.6 mph (±0.3 m s ⁻¹) or 1% of reading X	±0.4 mph (±0.2 m s ⁻¹) or 1% of reading
Starting Threshold	2.2 mph (1.0 m s ⁻¹)	2.2 mph (1.0 m s ⁻¹)	2.4 mph (1.1 m s ⁻¹)	0.9 mph (0.4 m s ⁻¹)
Distance Constant (63% recovery)	8.9 ft (2.7 m)	8.9 ft (2.7 m)	8.9 ft (2.7 m)	6.9 ft (2.1 m)
Output	ac voltage (3 pulses per revolution); 1800 rpm (90 hz) =19.7 mph (8.8 m s ⁻¹)	ac voltage (3 pulses per revolution); 1800 rpm (90 hz) =19.7 mph (8.8 m s ⁻¹)	ac voltage (3 pulses per revolution); 1800 rpm (90 hz) =19.7 mph (8.8 m s ⁻¹)	ac voltage (3 pulses per revolution); 1800 rpm (90 hz) =20.6 mph (9.2 m s ⁻¹)
<i>Wind Direction</i>				
Range	0-360° mechanical, 355° electrical (5° open)	0-360° mechanical, 355° electrical (5° open)	0-360° mechanical, 355° electrical (5° open)	0-360° mechanical, 355° electrical (5° open)
Accuracy	±3°	±5°	±3°	±3°
Starting Threshold @ 10° displacement	2.4 mph (1.1 m s ⁻¹)	2.4 mph (1.1 m s ⁻¹)	2.4 mph (1.1 m s ⁻¹)	1.0 mph (0.5 m s ⁻¹)
Damping Ratio	0.3	0.3	0.3	0.3
Damped Natural Wavelength	24.3 ft (7.4 m)	24.3 ft (7.4 m)	24.3 ft (7.4 m)	16.1 ft (4.9 m)
Undamped Natural Wavelength	23.6 ft (7.2 m)	23.6 ft (7.2 m)	23.6 ft (7.2 m)	14.4 ft (4.4 m)
Output	analog dc voltage from potentiometer—resistance 10 kohms; linearity 0.25%; life expectancy 50 million revolutions	analog dc voltage from potentiometer—resistance 10 kohms; linearity 0.25%; life expectancy 50 million revolutions	analog dc voltage from potentiometer—resistance 10 kohms; linearity 0.25%; life expectancy 50 million revolutions	analog dc voltage from potentiometer—resistance 10 kohms; linearity 0.25%; life expectancy 50 million revolutions
Power	switched excitation voltage supplied by datalogger	switched excitation voltage supplied by datalogger	switched excitation voltage supplied by datalogger	switched excitation voltage supplied by datalogger
<i>Physical</i>				
Operating Temperature	-50° to +50°C, assuming non-riming conditions	-50° to +50°C, assuming non-riming conditions	-50° to +50°C, assuming non-riming conditions	-50° to +50°C, assuming non-riming conditions
Overall Height	14.6 inch (37 cm)	14.6 inch (37 cm)	14.6 inch (37 cm)	15.0 inch (38 cm)
Overall Length	21.7 inch (55 cm)	21.7 inch (55 cm)	21.7 inch (55 cm)	25.6 inch (65 cm)
Main Housing Diameter	2.0 inch (5 cm)	2.0 inch (5 cm)	2.0 inch (5 cm)	2.0 inch (5 cm)
Propeller Diameter	7.1 inch (18 cm)	5.5 inch (14 cm)	7.1 inch (18 cm)	7.9 inch (20 cm)
Mounting Pipe Description	1.34 inch (34 mm) OD; standard 1.0" IPS schedule 40	1.34 inch (34 mm) OD; standard 1.0" IPS schedule 40	1.34 inch (34 mm) OD; standard 1.0" IPS schedule 40	1.34 inch (34 mm) OD; standard 1.0" IPS schedule 40
Weight	3.2 lbs (1.5 kg)	2.2 lbs (1 kg)	3.2 lbs (1.5 kg)	2.5 lbs (1.1 kg)
¹ Manufactured by RM Young (Traverse City, MI) and cabled by Campbell Scientific for use with our dataloggers.				

