

RRS *James Cook* 073 Cruise Report

Changing Oceans Expedition

18 May - 15 June 2012



March 2013



**UK Ocean Acidification
Research Programme**

Suggested citation: Roberts JM and shipboard party (2013) Changing Oceans Expedition 2012. RRS *James Cook* 073 Cruise Report. Heriot-Watt University. 224 pp.

Cover image: A greater forkbeard (*Phycis blennoides*) swims above cold-water coral reefs of the Logachev Mound Province (S Rockall Bank).

Contents	Page		
1. Introduction and acknowledgements	4		
2. Personnel	6		
3. Itinerary, cruise track and study sites	7		
4. Narrative	10		
5. Equipment reports	21		
5.1 Remotely Operated Vehicle	21		
5.2. CTD & associated sensors	27		
5.3 Stand-Alone Pumping System	32		
5.4 Moving Vessel Profiler	33		
5.5 Acoustic Doppler Current Velocity	35		
5.6 Acoustic Surveys	37		
5.7 SPI camera	42		
5.8 Box coring	43		
5.9 Gravity coring	48		
5.10 Spreaders	50		
5.11 Eddy lander	51		
5.12 Moorings	51		
5.13 Geographic Information System	51		
6. Initial results & further analysis planned	52		
6.1 Habitat survey & sampling	52		
6.2 Ship-board ocean acidification experiments	52		
6.3 Trophic and reproductive ecology of <i>Lophelia pertusa</i>	67		
6.4 Analysis of DMS and DMSP	74		
6.5 Microbiological sampling and analysis	78		
6.6 Sponge ecophysiology and trophic ecology	97		
6.7 Aquatic eddy correlation measurement of <i>in situ</i> benthic oxygen flux	101		
6.8 Oxygen microgradients in <i>Lophelia pertusa</i> polyps	110		
6.9 Sediment Profile Imagery (SPI) survey	112		
6.10 Spatial distribution and habitat use by deep-sea fish	118		
6.11 CTD hydrodynamics & carbon biogeochemistry	125		
7. Outreach activities	135		
8. References	137		
Appendix 1: Station list	143	Appendix 6: Instrument specifications	197
Appendix 2: CTD configuration	159	Appendix 7: Computing report	201
Appendix 3: Box core photographs	162	Appendix 8: BODC-fitted systems	206
Appendix 4: ROV track-plots	168	Appendix 9: Surfmet sensors	208
Appendix 5: Blog posts	181	Appendix 10: NetCDF description	210

1. Introduction and acknowledgements

JC073 set out to study the functional ecology of cold-water coral habitats at contrasting sites in the North Atlantic west of Scotland and Ireland. The overriding objectives of the cruise were to examine the potential impacts of ocean acidification and warming on the reef framework-forming coral *Lophelia pertusa* since this coral engineers complex habitats sustaining many other species. Specific objectives:

- Complete ROV surveys, sampling and *in situ* experimentation to support a variety of cruise objectives
- Conduct ship board experiments with CO₂-enriched seawater examining growth and metabolic responses of *L. pertusa* gathered by ROV
- Examine the microbial ecology of *L. pertusa* using samples collected with a purpose-built sampler unit
- Examine trophic and reproductive ecology of *L. pertusa*
- Investigate use of dimethylsulphide (DMS) and dimethylsulphoniopropionate (DMSP) by cold-water corals
- Examine the ecophysiology and biogeochemistry of deep-sea sponges
- Conduct hydrographic surveys to examine the water column properties (CTD + O₂) and carbonate chemistry above each site
- Examine the biogeochemical properties of the near-bed particle field using SAPS collection
- Complete surveys of the sediment-water interface along transects crossing different habitats associated with cold-water coral sites (SPI camera)
- Measure *in situ* O₂ consumption of reef fauna using eddy correlation lander (ROV deployed)
- Measure *in situ* uptake of stable isotope labelled compounds into reef fauna (spreader chambers & clod cards)
- Gather material to examine the growth history of reef mounds and recover fossil coral carbonate using gravity coring
- Examine the effect of coral habitat on local biodiversity patterns (box coring)
- Resample historic benthic biodiversity station on Hebrides continental slope (box coring)
- Complete novel habitat mapping using both ship and ROV-based multibeam echosounder surveys
- Examine spatial distribution and habitat use by deep-sea fish

In addition to the purely scientific objectives JC073 incorporated outreach activities including a 4-hour visit at sea by school children and teachers from Sgoil Lionacleit secondary school on Benbecula and a BBC One television crew. During the planning phase JC073 was extended by two days to complete ROV habitat surveys of the Hebrides Terrace Seamount on behalf of the UK Joint Nature Conservation Committee (JNCC).

All work at sea was recorded in UTC. Work patterns and plans were organised around the availability of the *Holland-1* ROV system which was mobilised with enough crew for a maximum of 12 hours ROV work in any 24 hour period. Before the cruise it was agreed that the science party would be divided into two 12-hour watches running from 0000-1200 and 1200-0000. The cruise was planned so that a CTD cast would take place at 1100 and ROV operations would begin at 1200 and end no later than 0000. Night shift operations varied from acoustic mapping, box coring, gravity coring, SPI camera transects, MVP surveys and CTD/SAPS deployments.

1200-0000	0000-1200
Attard, Karl	Alt, Claudia
Boyle (Milligan), Rosanna	Birchenough, Silvana (watch leader)
Byrne, Rowan	Büscher, Janina
Cook, Geoff	Donohue, Penelope
Cotton, Anne	Findlay, Helen
Hennige, Sebastian (watch leader)	Fitzek, Sarah
Huvenne, Veerle	Lyman, Nigel
Kazanidis, Georgios	Moreno Navas, Juan
Orejas, Covadonga	Victorero, Lissette
Polanski, John	Wicks, Laura

Acknowledgements

JC073 was funded through the UK Ocean Acidification (UKOA) research programme's Benthic Consortium project. Additional funding was secured from both the UKOA's national and international added-value award schemes and the Heriot-Watt University Principal's prize for public engagement. The added-value awards allowed the cruise programme to be significantly expanded to incorporate international scientific participation from Denmark, Germany, Spain and the USA. The HW public engagement prize covered the costs of the school childrens' visit at sea. Murray Roberts and participants from Heriot-Watt University acknowledge support from the University's Environment & Climate Change team and Silvana Birchenough acknowledges additional support from Cefas (contract DP309). The ROV surveys of the Hebrides Terrace Seamount were carried out on behalf of the JNCC with the agreement of the Natural Environment Research Council.

The Science Party acknowledge the significant efforts of Bill Richardson (Master) and the entire crew of the RRS *James Cook* who ensured a successful expedition. Further thanks are due Will Handley and the ROV team for their good humour and perseverance in the face of many challenging technical problems. Thanks are also due to Cruise Manager Darren Young and all at NMFSS for their careful help in the year leading up to the JC073 and to everyone involved in helping organise the school and BBC visit at sea.

2. Personnel

Name	Institution	Role/expertise
Science		
1. Alt, Claudia	National Oceanography Centre, UK	Benthic ecology and coring
2. Attard, Karl	University of Southern Denmark	Eddy correlation lander
3. Birchenough, Silvana	Cefas, UK	Watch Leader, SPI camera
4. Boyle (Milligan), Rosanna	University of Glasgow, UK	Deep-sea fish
5. Büscher, Janina	GEOMAR, Germany	OA and coral biology
6. Byrne, Rowan	Heriot-Watt University, UK	OA and coral biology
7. Cook, Geoffrey	Fish & Wildlife Service, USA	Microbiology & genetics
8. Cotton, Anne	University of Hull, UK	Microbiology
9. Donohue, Penelope	University of Glasgow, UK	OA and coral biology
10. Findlay, Helen	Plymouth Marine Laboratory, UK	Carbonate chemistry
11. Fitzek, Sarah	Heriot-Watt University, UK	OA and coral biology
12. Hennige, Sebastian	Heriot-Watt University, UK	Watch Leader, OA and coral biology
13. Huvenne, Veerle	National Oceanography Centre, UK	Mapping and log keeping
14. Kazanidis, Georgios	University of Aberdeen, UK	Deep-sea sponge biology
15. Lyman, Nigel	Cefas, UK	SPI camera
16. Moreno-Navas, Juan	Heriot-Watt University, UK	Hydrography, GIS and OFOP logging
17. Orejas, Covadonga	Instituto Español de Oceanografía, Spain	OA and coral biology
18. Polanski, John	University of Aberdeen, UK	Deep-sea sponge biology
19. Roberts, J Murray	Heriot-Watt University, UK	Principal Scientist
20. Wicks, Laura	Heriot-Watt University, UK	OA and coral biology
21. Victoreo Gonzalez, Lisette	Heriot-Watt University, UK	OA and coral biology
ROV		
22. Edge, Dave	National Marine Facilities Sea Systems, UK	ROV pilot
23. Handley, Will	Irish Marine Institute contractor	Team Leader, ROV pilot
24. Loukes, Richie	Irish Marine Institute contractor	ROV pilot
25. McCaffrey, Paul	Irish Marine Institute contractor	ROV pilot
26. Rowse, Martyn	Irish Marine Institute contractor	ROV pilot
Technical		
27. Burris, James	NMFSS, UK	CTD, MVP
28. Edwards, Terry	NMFSS, UK	Science Liaison, CTD, moorings
29. Maltby, Mark	NMFSS, UK	IT, ship's systems logging
30. Phipps, Richie	NMFSS, UK	Coring, dredging
31. Sneddon, Jon	NMFSS, UK	IT, ship's systems logging
32. Young, Darren	NMFSS, UK	Cruise Manager, coring
Ship		
33. Cantile, Ian	NMFSS, UK	Seaman
34. Davitt, Frank	NMFSS, UK	3 rd Engineer
35. Haughton, John	NMFSS, UK	Head Chef
36. Jenkins, Eric	NMFSS, UK	Senior Electro-technical Officer
37. Hood, Mike	NMFSS, UK	2 nd Officer
38. Kemp, Christopher	NMFSS, UK	2 nd Engineer
39. Link, Walter	NMFSS, UK	Chef
40. Lucas, Bob	NMFSS, UK	Chief Engineer
41. MacKenzie, William	NMFSS, UK	Seaman
42. MacLean, Andy	NMFSS, UK	Chief Petty Officer Deck
43. McDougall, Paula	NMFSS, UK	Purser
44. Mingary, Graham	NMFSS, UK	Steward
45. Minnock, Mick	NMFSS, UK	Chief Petty Officer Scientific
46. Piper, Carl	NMFSS, UK	Catering Assistant
47. Price, Dave	NMFSS, UK	Petty Officer Deck
48. Richardson, William	NMFSS, UK	Master
49. Sims, Kenneth	NMFSS, UK	Seaman
50. Slater, Gary	NMFSS, UK	3 rd Engineer
51. Smith, Pete	NMFSS, UK	Seaman
52. Smyth, John	NMFSS, UK	Engine Room Petty Officer
53. Tulloch, Daniel	NMFSS, UK	3 rd Officer
54. Warner, Richard	NMFSS, UK	Chief Officer

OA, ocean acidification; NMFSS, National Marine Facilities Sea Systems

3. Itinerary, cruise track and study sites

17 May 2012 scheduled cruise departure delayed by technical problems with ROV

18 May 2012 cruise departs King George V Dock, Govan

15 June 2012 cruise returns King George V Dock, Govan

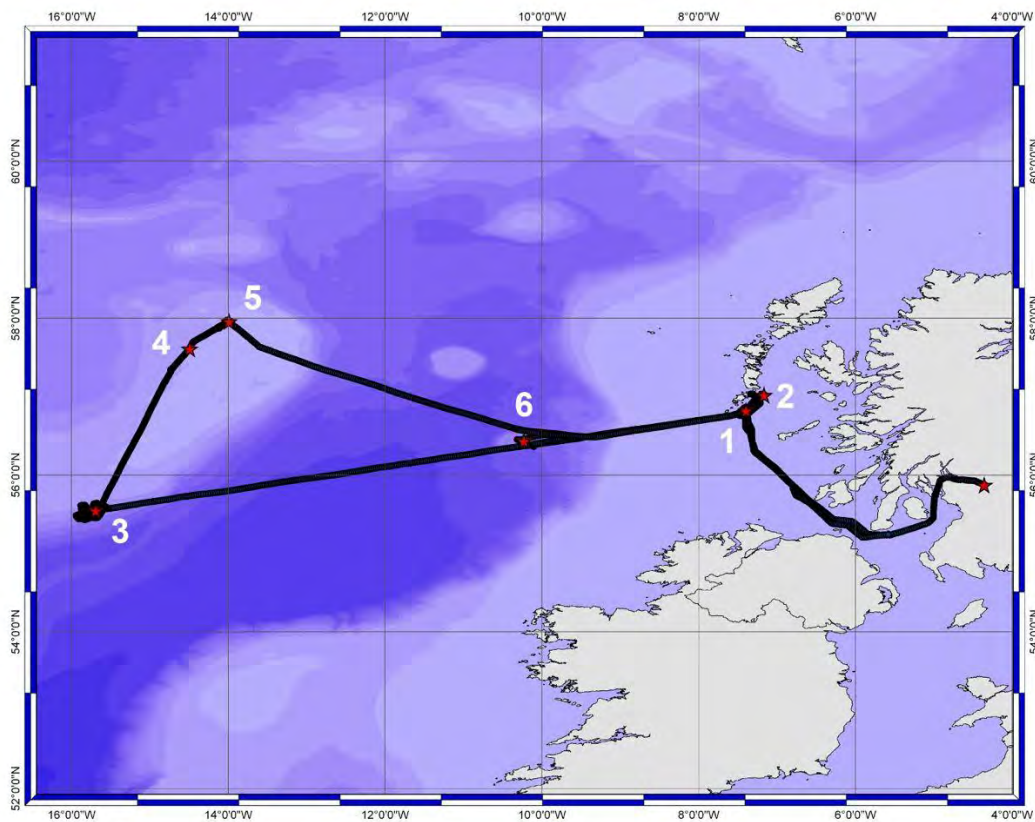

Figure 3.1 JC073 cruise track. (1) Mingulay Reef Complex, (2) Hellisay, (3) Logachev Mound Province, (4) *Pisces 9* dive site, (5) Marine Science Scotland Site 03, (6) Hebrides Terrace Seamount.

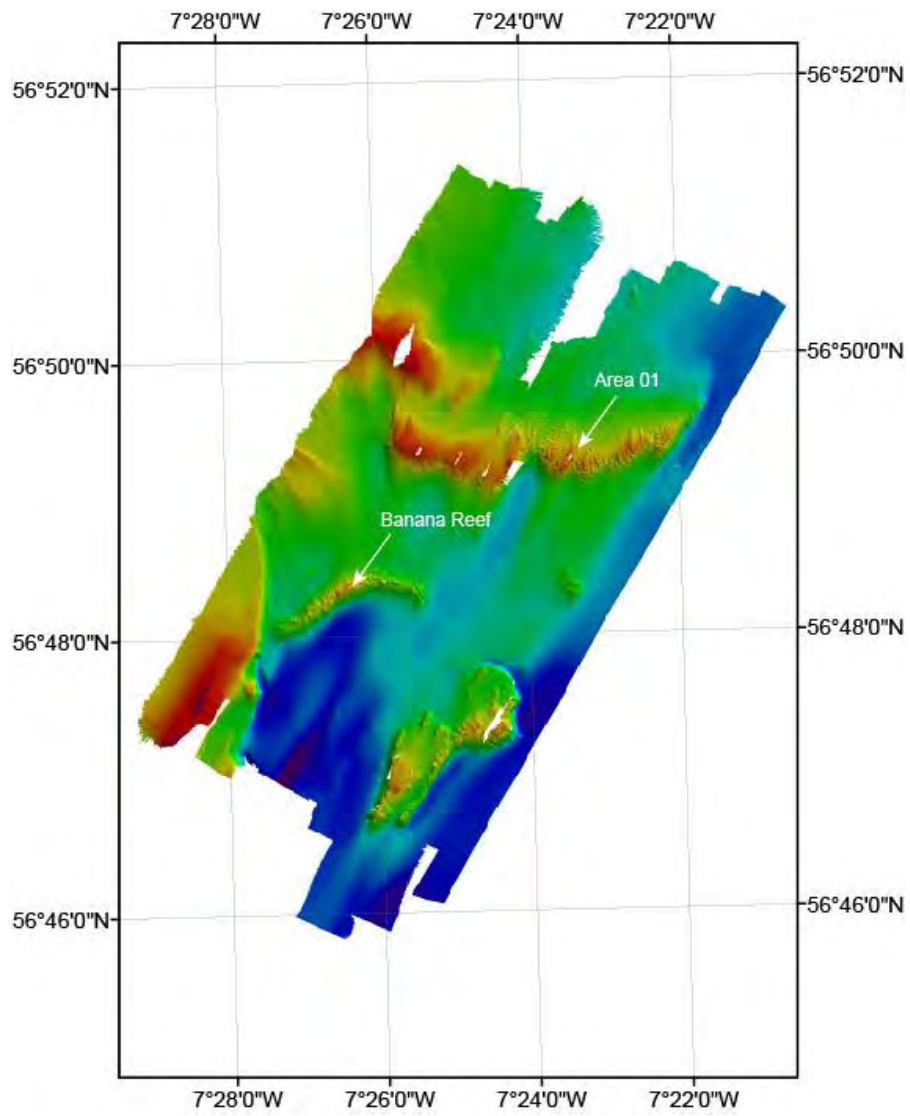

Figure 3.2 Study sites within the Mingulay Reef Complex

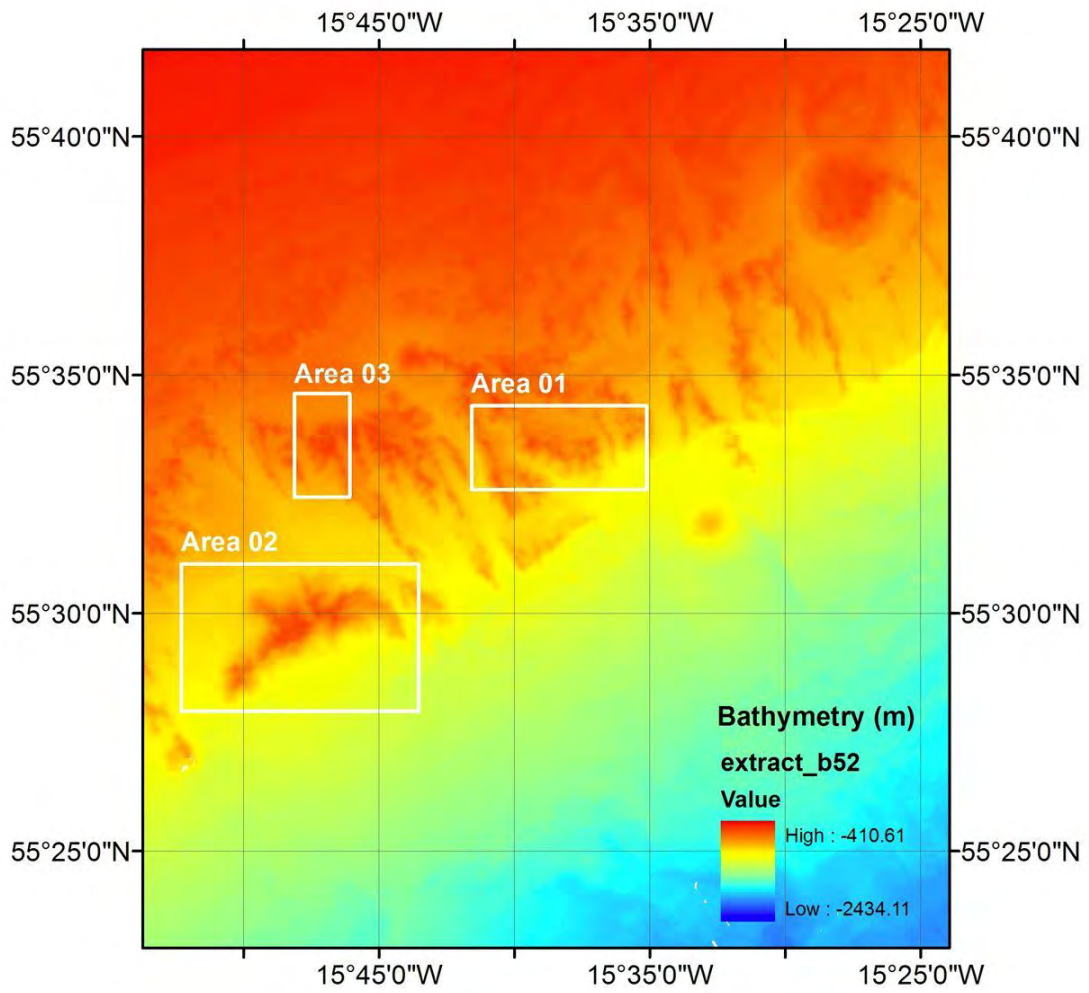

Figure 3.3 Study sites within the Logachev Mound Complex

4. Narrative

Thursday 17 May: Cruise departure scheduled for 0800z but delayed due to technical problems in the installation and integration of the *Holland-1* ROV system. The most significant of these issues included: (1) electrical fault within the ROV winch; (2) integration of the hired Reson multibeam system; (3) technical problems with the ROV Gyro unit (Phins Ixsea); (4) faults within the ROV tether management system (TMS); (5) loss of data transfer through one of the umbilical fibres. During the installation work it also became clear that the bottom-tracking Doppler unit was only operating with 3 of its 4 beams. The decision was made to progress the installation and rely on these 3 beams, most critical for near-bed multibeam surveys. Ship's Electro-Technical Officer was able to resolve the ROV main winch issue, tracing to a faulty connection on an emergency stop circuit. Following this the vessel's ETO was brought in once again and traced a fault in the tether management system to an incorrect electrical phase supply. Progress with ROV installation re-assessed at 1400z and decision made to delay departure till morning of Friday 18 May. Given these delays the school party and BBC film crew due to boat transfer and visit the ship on Saturday 19 May were warned that this operation was likely to be delayed.

Friday 18 May: Departure in the morning proved impossible and work on the ROV continued for most of the day with the ship still docked in Govan. Delays were compounded due to need to find an o-ring for a replacement connector needed for ROV Gyro Unit (Phins Ixsea). The boat-transfer was set back 24 hours. All involved were able to reschedule. The ship sailed at 1800z, 34 hours later than anticipated. Our ETA at the first station above the Mingulay Reef Complex (Area 1) is 1300z 19 May.

Saturday 19 May: Good progress made during our overnight transit with speeds over ground of around 11 kn. A Moving Vessel Profiler (MVP) calibration exercise was completed during the transit. This MVP calibration run took the vessel approximately 7 nm north of the first sampling station and after returning activities began at this station with a CTD cast including the GEOMAR deep-water pump. This pump was used to fill deck tanks with water from 40 m depth ready for the coral collections. The CTD and water pumping were followed by a trial SPI camera deployment which returned successful sediment profiles showing a rocky seabed with conspicuous crinoids. The secondary seabed imaging camera failed to operate correctly during this first trial. ROV operations (Dive #1) began at 1830z and concluded at 2300z. The dive successfully proved the high definition and stills cameras and succeeded in sampling live *Lophelia pertusa* for ship-board experiments. With the ROV on deck the vessel began its transit towards the Sound of Hellisay for the multibeam echosounder (MBES) survey planned overnight. This survey also places the *James Cook* close the location of the boat-transfer planned for tomorrow.

Sunday 20 May: Overnight MBES proceeded according to plan but no clear evidence for *Lophelia* coral reef was seen on the unprocessed bathymetric data. The survey was curtailed before the entire area was surveyed leaving the question of whether any reefs occur on the E-W trending contours at the eastern edge of the survey. The ship then repositioned to meet the *Boy*

James and boat-transfer the film crew from the BBC and a party of school children and teachers from Benbecula. This boat transfer took place in sheltered waters near North Bay (Barra) since winds gusting to 20 kn made it unsafe to consider a boat transfer over the reef survey site. With the visitors on board 11 members of the science party left the ship with the *Boy James* so that the total number allowed on the *James Cook* was not exceeded. The ship then made a transit south to Mingulay Reef Area 1 for ROV Dive #2. The ROV dived at 1033z while BBC and School visitors watched in the Main Laboratory area. Given the time needed to return to the boat transfer area, this dive was restricted to just 2 hours during which no sampling operations were planned. The visit proved successful and the visitors left at 1400z. The ship then returned from the boat-transfer area to reposition once again on Mingulay Reef Area 01 ROV Dive #3. This dive began at 1703z and ended at 2005z. The dive was largely unsuccessful due to significant problems in controlling the ROV manipulators. After approaching 2 hours only eight small sponge samples had been collected. Attempts to use a newly made 'coral sampler' proved futile because the sampler was too long and the manipulators were moving unpredictably. The decision was made to end the dive so the ROV team could investigate. Upon recovery the bio-box containing the only samples drained because of leaks exposing the sponges to the air. This negates the purpose of a bio-box and limited the samples use in ship-board experiments. Remaining ROV time was then used for CTD and water sampling using the GEOMAR pump to fill the deck tanks, starting at 2030. This was followed by CTD deployments and testing the stand-alone pumps (SAPS) in deck tanks of seawater. CTD sampling concluded at 0040z (21 May).

Monday 21 May: Today's work began with a series of four very successful SPI camera transects covering a variety of habitats around Mingulay Reef Area 01. These deployments continued until 1135z. At the 0830z daily briefing the ROV team reported that the vehicle was unable to dive since its hydraulic systems were malfunctioning. Having worked through their trouble-shooting guides the team had isolated the fault to three potential causes: a valve, a pump or a software control issue. Advice from the ROV manufacturers was being sought by telephone. Given this the decision was made to switch from ROV work to a CTD deployment with a trial SAPS deployment to assess the pumping times needed for this site. Following this an MVP survey was begun at 1412z. This survey was designed to follow a Scanfish survey loop carried out in 2009 during RRS *Discovery* 340b. The loop was completed in clockwise direction covering Mingulay Reef Area 01, Area 5 and Banana Reef. During this time the ROV team continued working to repair the vehicle and by early afternoon had been able to confirm the hydraulic pump was working correctly. They also reported that although the spares list indicated a replacement valve was on board, in fact the valve was not the correct type. From ~1800z onwards discussions involving the Master, PSO and ROV team revolved around securing and delivering a replacement valve using the *Boy James* boat-transfer vessel from Barra. The MVP survey was concluded at approximately midnight upon which activities shifted to box coring positions around Mingulay Area 01 to provide sediment for bioturbation experiments in areas where SPI camera surveys had been completed.

Tuesday 22 May: Box coring continued until 0538z but no cores were obtained. Although the SPI camera work, and previous surveys, indicated bioturbated muddy habitats were present we were not able to obtain a usable core. Without visually guided samplers coring in such heterogenous areas as the Mingulay Reef Complex is always an unpredictable activity. Work then moved to a six hour period of CTD casts with SAPS samples taken every two hours to examine both the carbonate chemistry and nature of suspended particulates associated with the pronounced tidal downwelling found across Mingulay Reef Area 01. CTD operations ended at 1228z and ROV diving began. The first dive of the day (#4) was intended to sample live coral, gather microbiological coral samples and survey for the eddy lander deployment. Live coral sampling to the bioboxes proceed well with a total of 11 samples taken. By comparing a ship-built coral sampling scoop with the ROV's suction sample the decision was made to use the suction sampler to retrieve small coral fragments, retain them on the nozzle's mesh and transfer them to the bioboxes. At 1430z the ROV motor failed and despite attempts to restart the dive had to be aborted and the ROV was recovered to deck at 1502z. The ROV team then worked on the vehicle until while the ship stood by. The ROV was again launched for Dive #5 at 1639z. This dive made 30 slurp sample collections of live coral, 6 microbiological samples to the Cook Sampler (named for its creator Dr Geoff Cook) and gathered 6 sponge samples for the Oceanlab team. All the samples were gathered with one manipulator on the port side of the vehicle since the starboard arm was not operating. The success of the port side manipulator sampling shows that the ROV team have successfully overcome many of the hydraulic pressure issues that were preventing manipulator use on 21 May.

Wednesday 23 May: Operations today began with CTD deployments with stand-alone pump (SAPS) sampling every two hours. This was followed by a brief (~1h) sub-bottom profiler survey to identify suitable sites for gravity coring sites on the edge of the Mingulay Area 01 reefs. Recoveries varied from just 0.5 m from the one reef core to 2.5 m off reef. Coring was followed by ROV operations with the first dive of the day (#6) dedicated to deploying the eddy correlation lander. The lander deployment frame prevented any sampling operations during this dive. The lander was successfully deployed at 1345z with a fix taken using a USBL beacon attached to the lander frame. Anticipated second ROV dive of the day at 1500z was delayed to 1548z due to light and thruster repairs and time required to reset sample drawers after inadvertently over-extending them after the eddy lander deployment. This dive (#7) completed a video transect from west to east along the crest of the Banana Reef. Poor visibility limited the value of this transect so the decision was made to relocate to Mingulay Area 01 and survey the eastern portion of the reefs where little visual survey data exist. The final dive of the day (#8) followed a transect designed to cross a range of habitats up and downslope. Once again visibility was relatively poor but the survey succeeded in imaging the habitats in this previously unsurveyed area. Alongside *Lophelia* reef habitat areas of cobbles and erect sponge were recorded.

Thursday 24 May: Work began with an 11 hour period of SPI camera transects crossing habitats around the Banana Reef. In total three transects were completed. Following the SPI deployments the CTD was deployed with the SAPS to sample the particle field above the Banana

Reef. ROV operations then began with the first dive (#9) to recover the eddy lander. The ROV reached the seabed at 1401z, the lander was located at 1407z, secured to the ROV at 1505z and recovered safely to the deck at 1520z. Data were downloaded and by early evening the first preliminary oxygen flux estimates were available. The last dive (#10) planned at the Mingulay site targeted live sponge and *Lophelia* microbiological sampling, alongside gathering high quality video and stills imagery. The ROV again dived Mingulay Area 01 and, now with two functional manipulators, quickly collected 9 sponge samples before moving to survey very large and extensive live *Lophelia* colonies some of which extended vertically for up to 3-5 m in height above surrounding seabed. At the end of the dive closely neighbouring orange and white *Lophelia* colonies were examined and the orange coral was sub-sampled for microbiology. The dive was ended at ~1800z to allow time to deploy a long-term current meter mooring to the north of the main reef complex at Mingulay Area 01. This single point current meter mooring was deployed at 1855z. Activities then shifted to box coring in the 250 m deep waters south of Banana Reef before leaving the Mingulay Area to steam to Rockall Bank. Despite several attempts and using both the USNEL and NIOZ corers no complete cores were taken, the only sample being of cobbles and mud recovered by the NIOZ corer. The decision was made to abandon coring and, slightly earlier than planned, begin the 288 nm transit to the Logachev Mound Province.

Friday 25 May: The science party met at 1000z to review progress made in the first six days of JC073. Despite the initial technical problems with the ROV the vehicle was now working very much more reliably, with a huge improvement in sampling rate now that both port and starboard manipulators can be used. The delays at the start of the cruise have meant that it was not possible to deploy the Oceanlab Spreader chambers and technical difficulties in integrating the near-bed Reson multibeam mean that these planned activities have not been achieved, and no sediment samples were obtained for bioturbation experiments. Despite these three setbacks all other objectives have been achieved and there was general agreement in the science party that work was proceeding well and most planned ship-board experiments were now begun using the live corals and other invertebrates sampled at Mingulay. Excellent weather during the transit allowed the ship to make good progress towards the Logachev Mounds and the ship arrived on station at 2322z where work began with a CTD deployment deploying the GEOMAR deep water pump to refill the deck tanks ahead of ROV sampling operations.

Saturday 26 May: Following water pumping a series of CTD and SAPS deployments were made over the first Logachev station (Logachev 01). This station is positioned over a coral carbonate mound selected west of previous NIOZ-RV *Pelagia* box core stations and seismic lines. The mound is 1.3 km W-E and approximately 0.8 km N-S. It rises from ~670 to 770 m giving an overall height of >100 m from the surrounding seafloor. The CTD-SAPS deployments were concluded at 0609z when activities switched to a sub-bottom profiler and EM120 multibeam echosounder surveys across the carbonate mound. Little clear evidence for fine-grained sediments suitable for bioturbation studies was found. The acoustic surveys ended at 1028z and the vessel repositioned to deploy a short-term current meter mooring before ROV dive #11

began to conduct a near-bed Reson 7125 multibeam echosounder survey planned to last ~10 hours. This dive began just 15 minutes late at 1215z and concluded at 2353z when the ROV left the seabed. This was the first time the Reson system had been integrated and used with the *Holland-1* ROV. The survey went relatively smoothly although was halted for phone calls to be made to Reson and to trouble-shoot navigational issues. On initial review it was clear that the data would require considerable post-processing and work to get good navigational information. For these reasons, the survey will not be able to inform any dive planning in the near future, somewhat limiting its immediate value at sea. During the ROV dive, the vehicle did approach the seabed confirming the mound supported coral framework. Since the multibeam transducers prevent near-bed survey it was not possible to examine the seabed in any detail.

Sunday 27 May: Activities began today with an 11 hour period set for SPI camera transects around and across the carbonate mound that forms the central site of activities for Logachev Area 01. A total of 2 transects were run, although the second transect gathered no data since the pins securing the SPI camera were accidentally left in place preventing profiles being produced. Delays in concluded the SPI transect used the time set aside for today's CTD deployment and activities moved straight to ROV deployment beginning at 1207z. In total three dives (#12, #13, #14) were completed today. These revealed a rich carbonate mound fauna with extensive areas of live coral and evidence for a clear zonation in the fauna that will be explored in later transects upslope. Dive #13 deployed two 'clod card' units from Dr Christina Müller and Dr Dick van Oevelen of the Netherlands Institute for Sea Research (NIOZ). These will be left in place for 5 days to examine flux of stable isotope enriched ammonium, glucose and bacteria to the carbonate mound fauna. The last dive of the day (#14) deployed the Eddy Correlation lander system. Using two grab handles and two manipulators to deploy proved less satisfactory than the single central handle used at Mingulay and unfortunately the lander was dropped on the seabed. Since no sign of damage could be seen in the high definition video the lander was deployed close the summit of this carbonate mound and the ROV recovered to deck at 2333z.

Monday 28 May: Today's work began with five gravity cores on mound summit and flank planned to last for a six hour period. Five cores were attempted with two cores recovering 0.9 m and 1.6 m respectively. Of the failed cores, some recovered coral fragments in the core catcher which were labelled and retained. Following coring a series of CTD and SAPS deployments were made between 0553z and 1217z. Today's ROV work was intended to deploy the Oceanlab Spreader systems. This dive was planned to follow a relatively long transect from off-mound (~900 m) up slope. However, this first dive with the spreaders (#15) was aborted after 2.5 hours because the spreaders were proving very hard to deploy due to their tendency to tip over on the seabed. The ROV was recovered to the deck and while lead was added to the spreader bases the dive schedule was replanned to insert an additional dive continuing the transect while sampling at selected locations. This dive lasted approximately four hours and succeeded in sampling live coral (*Madrepora oculata*) and sponges for ship-board experiments. The ROV was again recovered to deck to transfer these samples to deck tanks. A final dive then attempted for a second time to deploy the modified spreaders. However, this also failed because the lids of the

spreaders repeatedly detached from the cylindrical bodies. After 2.5 hours the ROV dive shift ended and the vehicle was brought back to the surface. One spreader was lost and it seems unlikely that further attempts will be made to deploy this equipment given that the time can be better used recovering sponge samples for ship-board experiments.

Tuesday 29 May: Today's activities began with a programme of 11 hours box-coring across three stations from off to on-mound. Despite using the larger NIOZ corer which has been used on the Logachev Mounds successfully in past NIOZ cruises our attempts were largely unsuccessful, although a few reasonable recoveries of coral framework and underlying sediment were made. At approximately 1000z the ROV team reported that their pre-dive checks had revealed noticeable cracking in welds within the Tether Management System (TMS). Given this ROV dives were put on hold while the team began repair work. CTD casts for carbonate chemistry and deep-water pumping took place 1120-1330z. Box coring then continued throughout the afternoon although most attempts were unsuccessful. However, at the end of this period two very good recoveries were obtained from the base of the mound with cores filled with an epifauna-rich reef framework and underlying sediment. At 1900z the ROV dived to collect the Eddy Lander (Dive #18). After several attempts during which the lander was knocked over it was secured to the ROV and recovered to deck. Although both electrodes were broken during recovery the lander instrumentation was intact. Given the time taken to recover the lander there was no time remaining for a sampling dive and a MVP survey was begun shortly after 2200z to complete a 14 hour survey loop crossing the Logachev 01 carbonate mound.

Wednesday 30 May: The MVP survey was ended at 1055z to allow the vessel to reposition for the first ROV dive to survey a large coral carbonate mound to the SW of the smaller Logachev 01 Mound that has been the focus of activities so far. This larger Logachev 02 Mound is separated from the main clusters of mounds by up to 4 km. It is a large 6 km long mound likely to have formed from the intergrowth of neighbouring mounds. Two transects were planned to survey the western and eastern flanks of this structure. Science activities during the first dive did not begin for approx. 1 hour while the ROV team configured a Doppler Velocity Log needed to improve ROV navigation, in particular for the near-bed ROV-multibeam deployments. Following this, the transect proceeded well ending at 1916z. The ROV was deployed for the second transect at 2047z and the transect continued through until 2348z. The final stages of this second transect seem to have reached the mound summit revealing extensive areas of reef framework, although little time remained to explore this area in much detail.

Thursday 31 May: Today's activities began with a series of SPI camera transects continuing the work started around the Logachev 01 Mound on Sunday 27 May. In total 14 transects were completed although the final transect was sampled less frequently to keep on schedule for the planned 1100z CTD cast. The CTD cast was taken in the deeper waters just south of Logachev 01 Mound above the off-mound site identified for the Eddy Lander deployment. The ROV dive was scheduled to begin at 1200z but did not begin until 1333z. This dive (#21) was to deploy the eddy lander system off-mound. A suitably flat deployment site was identified soon after reaching bottom and the lander deployed successfully using a lifting rope above the frame. The

ROV was then recovered to deck (1543z) for a survey/sampling transect across a previously uninvestigated coral carbonate mound. This dive (#22) began at 1640z but the ROV was recalled to the deck because the Bridge reported that the ship no longer had an operational starboard propeller. This problem was investigated but by 1720z the issue was not resolved and the dive was aborted. Work then moved to deploy the CTD and deep water pump to refill deck tanks and a contingency Science Plan to investigate particle flux from the carbonate mounds was developed using CTD-SAPS deployments North and South of the Logachev Area 01 site. Before this plan was brought into play the Bridge reported that the starboard propeller issue had been resolved by rebooting the control system and ROV activities were resumed. The survey and sampling dive was abandoned and the final planned dive of the day to sample around the clod cards deployed on 27 May was brought forward. This dive (#23) began at 2103z and ended at 2356z have successfully relocated and sampled around both clod card sites. During both dives today the ROV's port manipulator was not working due to a fault in the control unit.

Friday 1 June: Work today began with a box coring campaign to sample three sites from mound summit, flank and off-mound (large carbonate mound Logachev 02). The coring was not very successful with only 3 samples from a total of 8 deployments. Following the coring a CTD cast was taken at 1113z after which it was decided that the sea state and upcoming forecast (swell 2 m, rising to 3 m; wind 20 rising to 30 kn) precluded ROV work. Given this a MVP survey was assembled to replicate the previous design. In essence this runs a loop extending from the lower flanks of Rockall Bank in the north, crossing the large isolated coral carbonate mound (Logachev 02) and extending into 1000 m deep waters before returning north. This survey was designed to last 12 hours. The weather outlook was for sea states to worsen slightly so the Science Party agreed an alternate contingency plan to follow the MVP survey with CTD-SAPS deployments north and south of Logachev 02. The MVP survey proceeded smoothly until the Optical Plankton Counter (OPC) developed a fault and the towfish was recovered to assess at approximately 1800z. The OPC was replaced with a spare and the fish redeployed from 1930 - 0000z when it was recovered once again since the profiling unit was not gathering full profiles.

Saturday 2 June: Weather conditions deteriorated overnight and the rising swell made it unsafe to redeploy the MVP. The ship hove to until 1216z when multibeam and echosounder surveys were begun covering the area above Logachev sites 01 and 02. During today wind speeds increased to between 30 and 40 kns with swells up to 5-6 m. Acoustic surveys continued throughout the day with lines running with the swell producing useful data but lines against the weather had to be re-run. Given this progress was slow but steady throughout Saturday.

Sunday 3 June: Acoustic survey lines were concluded at 0957z whereupon work moved to carry out a CTD-SAPS study north and south of the large isolated coral carbonate mound (Logachev Area 02). This work began at 1114z with water pumping to refill deck tanks. Over the next 24 hours a total of 11 CTD casts and 6 SAPS deployments were made to examine the influence of tidal flows across the mound and whether there was any detectable evidence for particle transport from the mound itself. Wind gusts of up to 30 kns and heavy swell prevented any ROV operations.

Monday 4 June: CTD-SAPS operations ended at 1047z and since wind and swell conditions had moderated ROV operations could begin again. At 1211z ROV dive #24 began to recover the eddy lander system following its off-mound deployment. The lander was picked up at 1334z and the ROV recovered on schedule at 1402z. Following this, two dives were made to run survey and sampling transects across a previously unexplored coral carbonate mound. These revealed extensive areas of carbonate crust as well as steep expanses of coral framework ridges interspersed with flatter plateaus. The summit area of the mound revealed areas slightly deeper than the fringing ridge of coral framework with large expanses of sandy sediment. The varied facies seen during these dives made it an interesting target for ROV multibeam survey.

Tuesday 5 June: After two dives (#25, 26) the ROV was recovered to deck at 0014z and SPI camera transect work was begun at 0132z. These surveys were put on hold at 0435z since wind speeds had climbed to reach peaks of 30-40 kns. Later in the morning wind speeds lessened and SPI camera transects were resumed at 0719z. The swell was too great for ROV operations to begin at 1100z so SPI transects continued until 1249z when the ship repositioned to recover the current meter mooring deployed 2 km east of Logachev Area 01 on 26 May. The mooring was brought back to deck at 1440z and the ship repositioned to the ROV dive site. Although the vessel's heave had lessened a long, rolling swell meant that vessel pitch was close to 3, the safe limit for ROV deployment. Given this it was decided that the conditions were marginal for deployment and ROV work was put on hold with the ROV team agreeing to dive earlier tomorrow (1000z) if conditions allowed. In the meantime the vessel repositioned once again to begin an 18 hour campaign of CTD casts with SAPS deployments to fill in time points missed on 1 June in the survey north and south of Logachev 02.

Wednesday 6 June: The CTD-SAPS deployments were brought to an end at 1037z since weather conditions had moderated enough for ROV dives to resume. ROV dive #27 began at 1153z but was aborted after just a few minutes because the slurp sampler detached from its holster. The ROV dived again (#28) at 1215z and completed a 5-hour dive surveying and sampling Logachev Area 01 (transect running from N off mound to S reaching mound summit, a dive aborted on 31 May by the failure of the ship's starboard propeller). ROV dive #29 was intended to ground-truth sinuous terraces seen in the near-bed ROV-multibeam collected from Logachev Area 01. Unfortunately dive #29 was aborted at 170 m depth because of excessive movement of the ROV and TMS caused by vessel movement in the swell. Given the heavy swell and the forecast of worse weather developing south of the working area the decision was made to end operations at the Logachev Mounds and transit north to the *Pisces* Dive 9 site.

Thursday 7 June: Vessel arrived at first waypoint south of the *Pisces* Dive 9 site at 0630z and following a sound velocity probe deployment began an acoustic swath survey (EM710 and EM120 multibeam) while also deploying the MVP. The unprocessed swath data revealed the heavy iceberg scouring of this region of Rockall Bank. The first ROV dive (#30) of the day began at 1113z but was terminated at 1221z because the slurp sampler was drawn into the starboard side forward thruster. The ROV was recovered to deck to remove the slurp where it became clear that the thruster guards had been removed before this dive. The ROV team replaced the

thruster guards and the ROV dived again (#31). These first two dives both successfully located, surveyed and sampled the small *Lophelia* patch reefs ('Wilson rings') described by John Wilson during his 1973 *Pisces* manned submersible dives. The final dive of the day (#32) examined an area of circular raised topography in the south of the newly-gathered multibeam survey. During the dives it appeared that the coral frameworks had trapped significant sediment and were forming significant local build-ups, suggesting they are forming early stage coral mounds. The ROV was recovered to deck at 2359z.

Friday 8 June: Following ROV recovery work shifted to a swath mapping survey while steaming from the *Pisces* Dive 9 dive site NE towards the MSS_03 site supplied before the cruise by Marine Science Scotland. Upon reaching the MSS_03 site the series of swath lines were run across the area before the acoustic surveys were ended at 0858z. A CTD cast was then taken, with water from near-surface samples filtered and stored to see whether the very distinctive aquamarine tint to the seawater in this region relates to a coccolithophore bloom (an idea later borne out by satellite images sent from Plymouth Marine Laboratory showing a senescent bloom in this area). ROV dives (#33) resumed at 1035z using calibrated sidescan maps supplied by Veerle Huvenne from JC060. The transects were very successful in showing how well this 400 kHz sidescan record allowed ploughmark and coral reef features to be identified. Dive #33 ended at 1352z and the ship repositioned to ground-truth a second area of the 400 kHz sidescan. Dive #34 began at 1505z but was ended early because rapidly increasing swell conditions made it unsafe to continue with the dive. Given the weather conditions the decision was made to move on from Rockall Bank and begin the 15 hour transit to the Hebrides Terrace Seamount. This transit passed within view of Rockall, allowing many on board to glimpse the Rock through the mist.

Saturday 9 June: The ship arrived at the first dive site on the Hebrides Terrace Seamount at 0619z where work began with a CTD deep-water pump deployment to refill deck tanks with seawater. The CTD was then recovered, pump removed and redeployed to complete a full-depth cast sampling water at 1930, 1500, 1000, 500, 250, 50 and 10 m. After recovering the CTD at 0942z the ship repositioned to box core the first Hebrides Terrace slope site (1800 m) because swell conditions were too great to allow ROV dives. The box corer was only deployed once (approx. 30 cm deep, fine mud, partially slumped) before swell had reduced enough for ROV dive operations to begin. The vessel relocated and ROV dive #35 began at 1336z. The ROV's descent was greatly slowed by the sometimes significant (up to 45) roll on the ROV and TMS unit. However, after carefully considering vessel movement trends and weather prospects the dive continued with the vehicle reaching the seabed at 1539z. This first visual survey of the Hebrides Terrace Seamount followed a transect for the Joint Nature Conservation Committee running 3.3 km upslope on the seamount's NE flank. The survey revealed a diverse range of sub-habitats including coral reef framework, 'coral gardens' (bamboo, other gorgonian, black corals), exposed igneous rock, sediment-draped rock, gravel and areas with finer sediment. The end of this transect traversed up onto the mound summit where a relatively homogenous landscape of sediment, scattered stones and frequent xenophyophores (probably *Syringammina fragilissima*)

was found. The ROV left the seabed at 2238z and was recovered on deck at 2319z. The vessel then repositioned to continue box coring the 1800 m station begun earlier today.

Sunday 10 June: Box coring continued throughout the early morning using the USNEL corer. Of 4 deployments only 2 recovered any significant amount of sediment, and both these cores had slumped inside the box and were partially washed. Although imperfect these cores were processed and preserved. Box coring ended at 0821z to allow time for the ship to reposition for further JNCC habitat survey transect ROV dives on the Hebrides Terrace Seamount. The first dive (#36) began at 1010z to survey the seamount summit. The ROV reached the seabed at 1101z and completed a successful transect before leaving bottom at 1326z and recovering to deck at 1359z. The ship then repositioned to complete a transect up the southern slope of the seamount. This dive (#37) began at 1513z and ended at 2344z when the ship again repositioned to continue box coring upslope along the Hebrides Terrace at 1400 m water depth.

Monday 11 June: Following the problems obtaining reliable cores with the USNEL corer box coring was now carried out using the NIOZ corer. The first core failed to fire (wire wrapped around corer) but the subsequent two cores succeeded in recovering cores with overlying water that were processed and preserved. The vessel then transited to the next ROV dive station (northern transect on the Hebrides Terrace Seamount). The CTD with water pump were then deployed to replenish deck tanks. During this period the ROV team reported that there was evidence for further movement around the damaged welds in the TMS and given this deep dives would no longer be possible. The vessel then relocated to the 1800 m box core site and a third core was obtained at 1305z to finish the 3 cores needed from this site. The ship then moved upslope to the 1400 m site where box coring resumed at 1535z. Three further cores were taken at 1400 m before the vessel relocated to core at the 1000 m station with the first core taken at 2333z.

Tuesday 12 June: Box coring continued with the required three cores collected at 1000 m by 0432z. The vessel then began transit returning to the Mingulay Reef Complex where the next planned activity was an ROV near-bed multibeam survey. The ship arrived on station at 1140z and the ROV was deployed at 1216z. However, technical problems with the near-bed MBES system prevented its use until updated firmware was installed in the middle of the afternoon. While waiting for the technical issues to be resolved two CTD casts were taken to gather near-bed water for oxygen measurement (Winkler titration to support eddy lander data interpretation) and to refill deck tanks. After 2 hours while the vessel was on stand-by, the multibeam issues were resolved and a new dive began at 1603z. This dive (#39) was to produce high resolution bathymetric and backscatter maps of the coral mounds and trails within Mingulay Area 01 (including the site where the eddy lander was deployed).

Wednesday 13 June: Dive #39 ended at 0100z having completed the the near-bed multibeam survey across Mingulay Area 01. The ship then repositioned before beginning a multibeam swath survey across the Mingulay Reef Complex to collect EM710 bathymetric and backscatter data. This survey ended as planned at 1127z having covered the known coral reef complexes.

The ship then repositioned for the last day's ROV dives. The first dive (#40) completed a transect from west to east approaching Mingulay Area 01. Most of the coral mounds along this transect consisted of dead coral rubble and framework, although some large hemispherical colonies were found and sampled for microbiological and on-going physiological work. Additional samples of dead framework were taken to add to on-going studies of epifaunal species turnover across the reef complex. Dive 40 ended at 1919z and the ROV was recovered to deck to remove the microbiological sampler and live corals. The final dive of JC073 (#41) began at 2005z and ended at 2350z. This dive achieved its objectives in sampling more live coral for physiological work at Heriot-Watt University.

Thursday 14 June: The last planned activity for JC073 was a period of 6 hours swath mapping to add to the EM710 dataset covering the Mingulay Reef Complex. Swath lines began at 0006z and ended at 0600z whereupon the drop keel was recovered and the vessel began transit towards Govan. During the day the science party packed and cleaned the laboratory areas and finalised their contributions to the Cruise Report. The post-cruise assessment meeting took place at 1100z. The meeting reviewed the first draft post-cruise assessment form and the PSO's 5-page factual report outlining *Holland-1* ROV planning, mobilisation and operation at sea (see Section 5.1). This ROV report had been already agreed as a fair factual record during earlier discussions between the PSO, Captain and head of ROV team at sea (William Handley). Underway sampling was ended at 1800z.

5. Equipment Reports

5.1 Remotely Operated Vehicle (Murray Roberts)

5.1.1 Background and programmatic context

The UK Ocean Acidification programme's NERC Benthic Consortium applied and was granted two periods of seetime to be administered, as with other NERC awards, through National Marine Facilities Sea Systems (NMFSS) at the National Oceanography Centre (NOC, Southampton). The first seetime period allocated 3-days to collect cold-water corals (*Lophelia pertusa*) to establish a long-term experiment. These three days were programmed as RRS *Discovery* cruise 367 which was added to the Pelagic Consortium's month-long cruise D366 in 2011. The second seetime period granted was a month-long ISIS ROV cruise to survey, sample and experiment within cold-water coral habitats at the Mingulay Reef Complex (Hebrides) and Logachev Mounds (Rockall Bank). This second cruise was scheduled for summer 2012 but following the loss of the ISIS vehicle, the cruise was without an ROV. In late 2011 and early 2012 NMFSS and the PSO corresponded over a suitable replacement ROV. Two vehicles were considered, a Ministry of Defence SubAtlantic Commanche and the Irish Marine Institute SMD Quasar 'Holland-1'. After initial discussions and a site visit to see the Commanche ROV and meet the operators it was decided to focus plans on the *Holland-1* system. All contractual negotiations took place between NMFSS and the Irish Marine Institute.

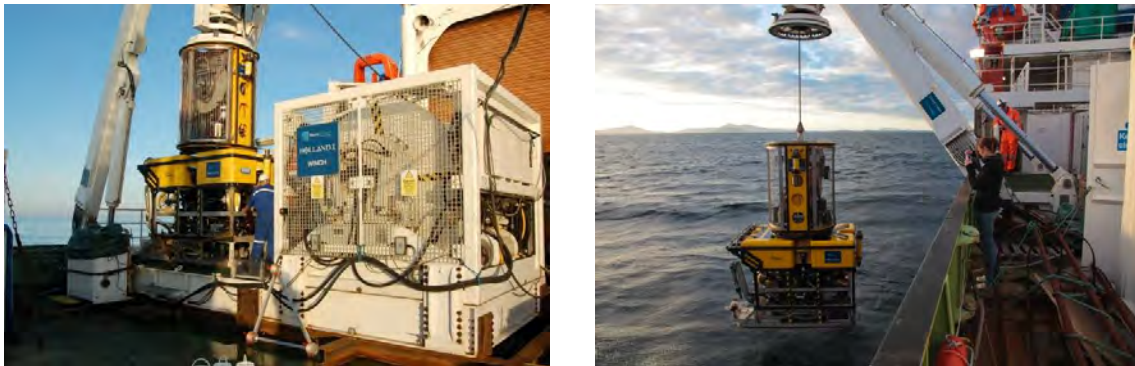

Figure 5.1 *Holland-1* remotely operated vehicle. Launch and recovery system on board JC073 (left). ROV being deployed to dive the Mingulay Reef Complex (right). The tether management system is the cylindrical unit above the main vehicle.

5.1.2 Activities pre-cruise

ROV operations during JC073 were planned before the cruise through the PSO, the ISIS team (NMFSS) and the Irish Marine Institute (Aodhan Fitzgerald & Will Handley). Following cruise planning meetings and earlier email and telephone correspondence the work needed to plan ROV dive schedules and gear integration proceeded smoothly. In the months leading up to the cruise discussions between researchers bringing equipment to interface with *Holland-1* and the ROV team increased. This aspect of the planning process went smoothly and, with the exception of one system (the Oceanlab 'spreader' units), the other scientific equipment was successfully

deployed and recovered as planned during JC073. The Reson 7125 multibeam unit hired for this cruise was mechanically integrated before mobilisation but the transducer head and electronic integration not undertaken until mobilisation in Govan.

Thanks are due to all involved for the time taking in this pre-cruise planning which undoubtedly made work at sea far smoother.

5.1.3 ROV mobilisation

ROV mobilisation began with general cruise mobilisation in Govan on Saturday 12 May. Heavy rain and high winds on Sunday 13 May meant construction of the steel frame for the ROV's Launch and Recovery System (LARS) was delayed by a day. The ship's main crane was not operational during the mobilisation and was not available during the cruise. This also meant that the ROV and Tether Management System (TMS) could not be easily unstacked at sea if this had become necessary, without additional risk assessment and liaison with NMFSS regarding the crane's use at sea. Mobilisation of science party's equipment and supplies began on the morning of Monday 14 May, and the ship was scheduled to sail at 0800z on Thursday 17 May. However, technical difficulties and missing spares meant the ROV system could not be declared operational in time and the cruise departure was delayed.

The most significant of the technical issues included: (1) electrical fault within the ROV winch; (2) integration of the hired Reson multibeam system; (3) need to integrate an Ixsea Phins inertial measurement unit supplied later than requested as a replacement for the originally planned Octans gyro unit; (4) establishing optical fibre continuity through the ROV tether management system (TMS); (5) time needed to attempt repair of Marine Institute's HD camera system followed by integration of the NMFSS Mini Zeus HD camera in its place. During the installation work it also became clear that the bottom-tracking Doppler unit had one faulty beam (of 4 in total). The decision was made to progress the installation and rely on the 3 functional beams, most critical for near-bed multibeam surveys. The ROV team asked the Ship's Electro-Technical Officer (ETO) to assist with the ROV winch fault and he was able to trace the problem to a faulty connection within the high oil temperature cut-out circuit.

Progress with ROV installation re-assessed at 1400z on Thursday 17 May and decision made to delay departure until the following morning. Given these delays the school party and BBC film crew due to boat transfer and visit the ship on Saturday 19 May were warned that this operation was likely to be delayed.

Departure in the morning of Friday 18 May proved impossible and work on the ROV continued for most of the day with the ship docked in Govan. Delays were compounded due to need to find an o-ring for a replacement connector needed for main fibre connector to the ROV pod, since the spare connector was not complete with o-rings. The boat-transfer was set back 24

hours. All involved were able to reschedule. The ship sailed at 1800z, 34 hours later than anticipated.

A further implication of the delays in the mobilisation was that the scientific party were unable to finalise protocols for handling video media and other data with the ROV team until the ship had sailed.

5.1.4 Work at sea

The second ROV dive (Sunday 20 May) of the cruise was limited by difficulties in controlling the two manipulator arms. This led to slow sample recovery (e.g. 8 small sponges collected over a 2 hour period). Upon recovery the ROV bioboxes drained exposing the contents to the air and, in the case of sponge samples intended for physiological experiments, making them unusable. On Monday 21 May ROV operations were halted while the team investigated the problems with the ROV manipulator arms. The team isolated the fault to three potential causes: a valve, a pump or a software control issue. Advice from the ROV manufacturers SMD was sought by telephone and no ROV dives were carried out leading to 12 hours ROV down-time. The following day ROV operations resumed at 1258z but were ended at 1430z when the ROV motor tripped. Dive #3 was aborted when the motor could not be restarted. The ship stood-by while advice was sought from SMD. Following this adjustments were made and dive operations resumed at 1639z after 4 hours ROV down-time. Only the port manipulator arm was working on this dive. ROV work then continued largely as planned and by Thursday 24 May with both manipulator arms working. Although not thought to be causing any problems a spare hydraulic valve was delivered to the ROV team using the *Boy James* from Castlebay in the early evening of Wednesday 23 May.

The first dive in the Logachev Mound area completed a near-bed multibeam survey. This dive (#11) began just 15 minutes late at 1215z and concluded at 2353z when the ROV left the seabed. This was the first time this generation of Reson system had been integrated and used with the *Holland-1* ROV. The survey went relatively smoothly although was halted for phone calls to be made to Reson and to trouble-shoot navigational issues. On initial review it was clear that the data would require considerable post-processing and work to get good navigational information. For these reasons, the survey results could not inform any dive planning during the cruise, limiting its immediate value at sea.

On Tuesday 29 May the ROV team reported significant cracking in welds within the Tether Management System (TMS). ROV dives were put on hold while the team installed supporting tie rods to strengthen these welds. ROV operations resumed at 1900z (7 hours ROV downtime). Dives on Thursday 31 May were limited to using the starboard manipulator arm since the control unit for the port arm had developed a fault in its control unit. The port manipulator was repaired on Saturday 2 May, and sampling operations were greatly improved following this.

The last deep dive of the cruise was cancelled on Monday 11 June because the ROV team reported that the damage associated with the cracked TMS welds showed signs of worsening. This meant that the dive designed to sample along a seamount transect was not possible, and given that the earlier dives were focussed upon habitat survey the level of sampling achieved at the seamount was far lower than desired (9 hours ROV downtime).

The last near-bed multibeam dive of the cruise was delayed by 4 hours because, despite successful pre-dive checks, the hired Reson 7125 system failed to operate correctly when the ROV was deployed. Following phone calls to Reson the fault was traced to corrupted firmware and once this was supplied by email attachment from Reson the system was restored and the dive resumed. This work took 4 hours during which CTD activities were brought forward for 2 hours and ship stood-by for 2 hours.

Other operational issues:

- One more ROV pilot would have given 24 hours operations. This would have doubled the potential dive time during JC073 and eliminated the need to schedule dives according to watch patterns as opposed to scheduling dives when weather and swell conditions were most appropriate.
- During JC073 there was an on-going discrepancy between ROV depth display and depth logged by on board CTD.
- There were several KiPro digital video recorder crashes in ROV van. The science team needed to use digital video tape back-up since there was no back-up KiPro with the *Holland-1* system. Two hours of high definition video were completely lost because of this issue.
- There was frequently a visible shake seen in High Definition video camera pan & tilt unit. This limits usefulness of video, especially when zoomed into smaller subjects.
- The pan & tilt unit is limited in its controllability with rapid and jerky movements of the camera leading to limited finesse in its filming.
- ROV CTD unit failed and was replaced with an NMFSS microCAT instrument from a JC073 mooring.
- It was not possible to maintain a reliable ROV main camera feed to the Bridge during JC073.

5.1.5 Downtime due to ROV issues

Lost science time (no scientific activities):	36 hours
Cancelled ROV dives (other scientific activities brought forward)	30 hours
<i>Total downtime associated with ROV mob/operational delays</i>	<i>66 hours</i>

5.1.6 Conclusions

Given the substantial technical difficulties noted above the ROV team are to be congratulated on their hard work and commitment to delivering a successful series of science dives. The entire team showed an extremely positive and helpful attitude throughout, and in the latter stages of the cruise agreed to make the ROV available for an additional 2 hours per day to catch up on some of the time lost to technical issues (while remaining within statutory hours of rest requirements).

The High Definition video proved its worth throughout the cruise and even a quick review of the footage is revealing cryptic species and other important details. Similarly the digital stills taken during the cruise are of very high quality and will provide a valuable resource for all the cruise participants and for future publications. Sampling activities were hampered initially by technical problems with manipulator arms but once these issues were resolved and the ROV pilots gained more experience with their use the rate of sampling improved noticeably. The clear-comms communication between ROV van, Main Laboratory area and Bridge was very effective.

The most significant concern during ROV operations on JC073 was the potential for the cracked TMS welds to bring an end to all ROV operations. Unusually fine weather conditions allowed dives to continue, but if that had not been the case the reduced weather window imposed by this damage would have severely curtailed scientific activities. The evidence for worsening damage reported on 11 June led to the loss of the deepest planned dive of the cruise and the loss of most of the planned sampling time on the Hebrides Terrace Seamount. This will impact upon future research planned with the coral *Desmophyllum dianthus* (seen on earlier seamount dives), including a recently-funded NERC grant application between NOC and Heriot-Watt University.

The implications of damage to the TMS would have been greatly amplified by: (1) the lack of ROV umbilical floats on board; (2) the risk that the ship's main crane might not have been permitted to perform the lift needed to unstack the ROV and TMS. Thus the vessel would have had to return to port to collect floats to deploy the ROV without its TMS (live boating). A conservative estimate is that this would have cost at least 2 days of shiptime.

5.1.7 Recommendations

- Any future cruises with *Holland-1* should employ one additional ROV pilot and provide 24 hour operations. This would fully capitalise on the significant mobilisation and operational cost of the system and allow deployments as and when weather is suitable.
- Cruise planning meetings involving deep-water ROV mobilisations should take place earlier to allow sufficient lead time for supplies such as cables to be manufactured.
- More time is needed to mobilise this system and account for any weather-related downtime than was provided for JC073.

- Complex technical integrations such as multibeam sonar need to be carried out before mobilisation on the ship.
- There is a clear need to ensure sufficient spares & supplies are shipped to avoid delays in mobilisation.
- A multi-chamber slurp sampler would greatly improve versatility of sampling options.
- It would be valuable to allow the scientists in the ROV van the option of taking control of the digital stills camera during dives.
- NERC vessel ROV cruises should use clear comms as a matter of course to maintain clear open communication between ROV van, Main Lab and Bridge.
- The Bridge should as a matter of course be able to see the ROV main camera output.
- The vessel's main crane should be fully operational before embarking on any deep-water ROV work where there is the potential need to unstack ROV and TMS while at sea for repair, maintenance or to move to live boat deployment.
- When mobilised, the *Holland-1* system should be equipped for live boating with a full set of main umbilical floats.

5.1.8 ROV Imaging Systems

Primary Cameras

High definition video camera:	Insite Mini Zeus camera with direct HDSI fibre output
Digital stills camera:	Kongsberg 14-208
Pilot pan and tilt:	Kongsberg 14-366
Fixed zoom camera:	Insite Pegasus plus

Lights

2x 400 Watt Deep-sea Power & Light SeaArc2 HMI lights
 2x 25,000 lument Cathx Ocean APHOS LED lights

Lasers

2x Deep-sea Power & Light lasers 100 mm spacing

5.1.9 ROV dive personnel and logging

All ROV dives involved two pilots and two scientists. The lead scientist was responsible for ensuring dive objectives were met and the assistant was responsible for electronic log keeping and video media management. Dives were recorded both on paper logsheets and also by keeping a running electronic event log on the Ocean Floor Observation Protocol (OFOP) system supplied by Heriot-Watt University. Calibrated maps were prepared before each dive for the OFOP system. Following each dive the High Definition main camera video and all DVDs from other camera feeds were copied to 6TB My Book hard drives.

5.2. CTD & associated sensors (Helen Findlay)

5.2.1. Instrument configuration

The instrument configuration was as follows:

- Sea-Bird *9plus* underwater unit, s/n: 09P-46253-0869
- Frequency 1 - Sea-Bird 3 Premium temperature sensor, s/n: 3P-4782
- Frequency 2 - Sea-Bird 4 conductivity sensor, s/n: 4C-2580
- Frequency 3 - Digiquartz temperature compensated pressure sensor, s/n: 100898
- Frequency 4 - Sea-Bird 3 Premium temperature sensor, s/n: 3P-2674
- Frequency 5 - Sea-Bird 4 conductivity sensor, s/n: 4C-2231
- V0 - Sea-Bird 43 dissolved oxygen sensor, s/n: 43-0619
- V2 - Benthos PSA-916T 7Hz altimeter, s/n: 41302
- V3 - WET labs Turbidity sensor, s/n: 759R
- V5 – Biospherical/Licor PAR/Irradiance sensor, s/n: 11
- V6 - Chelsea Aquatracka MKIII fluorimeter, s/n: 088195
- V7 - Chelsea Aquatracka MKIII Transmissometer, s/n: 161048

Ancillary instruments & components:

- Sea-Bird *11plus* deck unit, s/n: 11P-19817-0495
- Sea-Bird 24-position Carousel, s/n: 32-31240-0423
- 24 x Ocean Test Equipment 10 L water samplers, s/n: 01B to 24B inc.
- Stand Alone Pumps, SAPS (Challenger Oceanic)

5.2.2. CTD Operations

A total of 51 CTD casts were completed on this cruise numbered sequentially, and additionally associated with a cruise activity number JC073_XXX. See Table 5.1. for dates, cast numbers and activities.

The pressure sensor was located 30 cm below the bottom and approximately 75 cm below the centre of the 10 L Niskin water sampling bottles.

The carousel was fitted with a complete set of 24 water samplers, except on casts when the Stand Alone Pump (SAP) was fitted for organic carbon (POC and DOC) sampling (see SAP section 5.3.). The SAP was fitted in place of two of the Niskins (#20 and #21). See table 5.1 for dates and cast numbers of when SAP was fitted on casts.

The deep-water pump was attached to the carousel for filling the coral deck tanks. See table 5.1. for dates and cast numbers of when deep-water pump was fitted to the carousel. When the deep-water pump was used, the CTD was lowered to approximately 40 m and the pumping took place for as long as was required to fill the water containers (approx. 1 h). No bottles were fired during these casts and full water column profiles were not carried out.

The configuration file used was the JC073_pri_cond_NMEA.xmlcon (see Appendix 2). No sensor failures were noted.

Table 5.1 CTD carousel activities and cast list

Date	Activity No.	Cast	Event
20/05/12	JC073_001	1	Deep-water pump
20/05/12	JC073_008	2	Deep-water pump
21/05/12	JC073_009	3	CTD & water sampling (yoyo, CTD 3a-3g)
21/05/12	JC073_015	4	SAP, CTD & water sampling
22/05/12	JC073_023	5	SAP, CTD & water sampling
22/05/12	JC073_024	6	SAP, CTD & water sampling
22/05/12	JC073_025	7	SAP, CTD & water sampling
23/05/12	JC073_028	8	SAP, CTD & water sampling
23/05/12	JC073_029	9	SAP, CTD & water sampling
23/05/12	JC073_030	10	SAP, CTD & water sampling
24/05/12	JC073_044	11	SAP, CTD & water sampling
25/05/12	JC073_052	12	Deep water pump
26/05/12	JC073_053	13	SAP, CTD & water sampling
26/05/12	JC073_054	14	SAP, CTD & water sampling
28/05/12	JC073_068	15	SAP, CTD & water sampling
28/05/12	JC073_069	16	SAP, CTD & water sampling
28/05/12	JC073_073	17	SAP, CTD & water sampling
29/05/12	JC073_087	18	CTD & water sampling
29/05/12	JC073_088	19	Deep-water pump
31/05/12	JC073_098	20	CTD & water sampling
31/05/12	JC073_101	21	Deep-water pump
01/06/12	JC073_111	22	CTD & water sampling
03/06/12	JC073_114	23	SAP, CTD & water sampling
03/06/12	JC073_115	24	CTD profile only
03/06/12	JC073_116	25	SAP, CTD & water sampling
03/06/12	JC073_117	26	CTD profile only
03/06/12	JC073_118	27	SAP, CTD & water sampling
04/06/12	JC073_119	28	SAP, CTD & water sampling
04/06/12	JC073_120	29	CTD profile only
04/06/12	JC073_121	30	SAP, CTD & water sampling
04/06/12	JC073_122	31	CTD profile only
04/06/12	JC073_123	32	SAP, CTD & water sampling
04/06/12	JC073_123	33	CTD profile only
05/06/12	JC073_131	34	CTD & water sampling
05/06/12	JC073_132	35	CTD & water sampling
05/06/12	JC073_133	36	SAP, CTD & water sampling
06/06/12	JC073_134	37	SAP, CTD & water sampling
06/06/12	JC073_135	38	CTD profile only
06/06/12	JC073_136	39	CTD profile only
06/06/12	JC073_137	40	CTD profile only
06/06/12	JC073_138	41	CTD profile only
06/06/12	JC073_138	42	CTD profile only
06/06/12	JC073_138	43	CTD profile only
06/06/12	JC073_138	44	CTD profile only

06/06/12	JC073_139	45	SAP, CTD & water sampling
07/06/12	JC073_149	46	CTD & water sampling
09/06/12	JC073_152	47	Deep-water pump
09/06/12	JC073_153	48	CTD & water sampling
11/06/12	JC073_165	49	Deep-water pump
12/06/12	JC073_175	50	CTD & O ₂ water sampling only
12/06/12	JC073_176	51	CTD profile only

5.2.3. Data processing

The CTD cast data were post-processed using the SBE Data Processing (V7.21g) software. The raw data files were converted through the following steps as recommended by BODC basic on-board data processing guidelines for SBE-911 CTD (version 1.0, October 2010):

- Data Conversion
- Bottle file generation
- Filter
- Align CTD
- Cell Thermal Mass
- Loop Edit
- Derive
- Bin Average: 0.5 seconds (“2 Hz”) and 0.5 m intervals (“halfm”)

Data available:

- Temperature (°C)
- Conductivity (S/m)
- Pressure (db)
- Salinity (PSU)
- Beam transmission (%)
- Oxygen (mg/L)
- Turbidity (m⁻¹/sr)
- Fluorescence (µg/L)
- Density (Kg/m³)
- PAR/Irradiance

5.2.4. Cross-calibration for oxygen (Karl Attard)

Oxygen measurements were made from the water column to compare with the CTD. Dissolved oxygen was measured using the automated Winkler titration, with a polarographic electrode sensor, using standard methods (Hansen, 1999) summarised below.

Collection and fixation of the oxygen samples: 250 ml borosilicate glass bottles with ground glass stoppers were used for oxygen sampling from the CTD rosette. Bottles were filled with water by siphoning water from the Niskin bottles. At least twice the volume of the sample bottle was run to waste to displace air bubbles. 1 cm³ manganous sulphate, followed by 1 cm³ alkaline iodide solution was added to each bottle. Immediately after the second reagent was added, the stopper was replaced, ensuring no air bubbles were included in the sample. The bottle was shaken to allow the manganous hydroxide to precipitate, settle and then shaken again.

Standardisation of sodium thiosulphate reagent: Standardisation was carried out by titrating sodium thiosulphate against an accurate volume of potassium iodate solution of accurately known concentration. Using a glass pipette 5 ml potassium iodate standard solution was added to the reaction vessel. One ml alkaline iodide solution and 1 ml of 5 M sulphuric acid was then added, before adding a stirring magnet, and auto-titrating with sodium thiosulphate solution. This was repeated 3 times to reduce variation on the titre volume, until consistent by 0.005 ml or less.

Titration of the sample: The stopper was carefully removed from the sample bottle, and 1 ml of 5 M sulphuric acid was pipetted into the sample. A magnetic stirrer was placed into the sample bottle and auto-titration was carried out using sodium thiosulphate solution with an accurately determined molarity, as explained above.

Calibration was carried out at the start and at the end of the cruise. The metadata are shown in Table 5.2, and comparison with the CTD O₂ concentration data are shown in Figure 5.1. Except for on cast 11, at 15 m, the CTD O₂ concentration is consistently lower than the O₂ concentration sampled from the bottles and using the Winkler titration method.

Table 5.2 Metadata for sample collection for Winkler analysis

Date	CTD Cast No.	Depth (m)	O ₂ conc. (mg/l)
24/5/2012	11	15	9.120
24/5/2012	11	15	9.092
24/5/2012	11	15	9.008
24/5/2012	11	130	8.567
24/5/2012	11	130	8.748
24/5/2012	11	130	10.119*
12/6/2012	50	16	8.524
12/6/2012	50	16	8.535
12/6/2012	50	16	8.540
12/6/2012	50	170	10.072
12/6/2012	50	170	10.067
12/6/2012	50	170	10.026

*Precipitate did not dissolve completely after acid addition- excluded from calibration

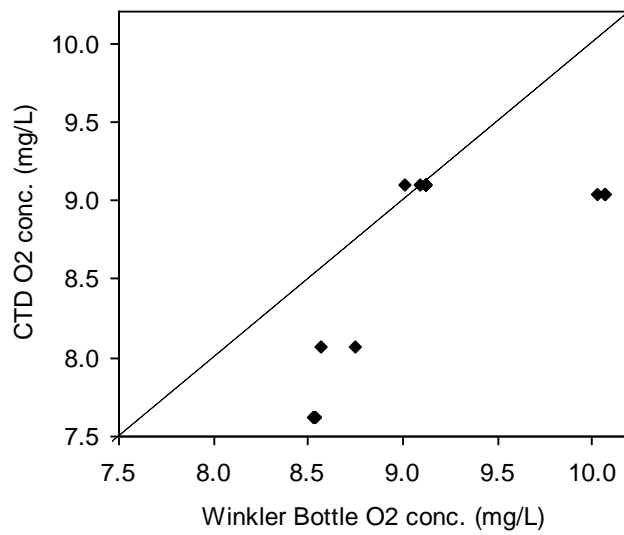

Figure 5.2 Comparison curve between CTD O₂ values and the O₂ concentrations from Winkler titration of bottle samples.

5.2.5. Salinometry (Terry Edwards)

The salinometer 8400B serial number 65764 was sited in the electronics workshop due to low temperature work in the CT lab. Ambient temp was 21 degrees. Salt samples were taken at irregular intervals based around scientific requirements. Only 24 samples were taken. Figure 5.3 shows corrected errors.

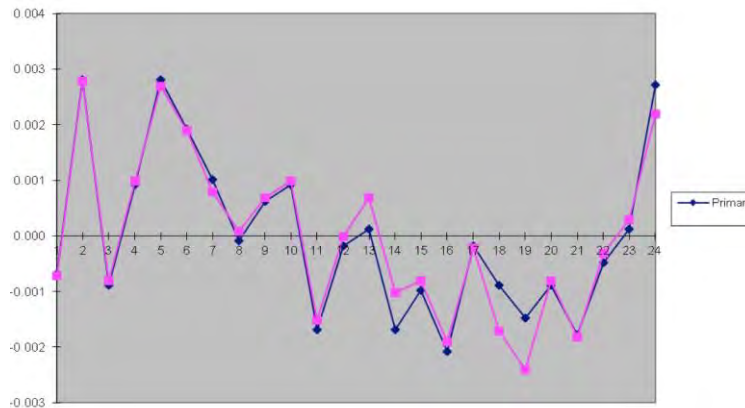

Figure 5.3 Corrected errors for the CTD primary and secondary salinity sensors

5.3 Stand-Alone Pumps (Laura Wicks)

To collect large volumes of seawater, and examine the particulate organic carbon and nitrogen above the coral reefs, we used stand-alone pumps or SAPs (Challenger Oceanic) following the approach of Kiriakoulakis *et al.* (2004). The battery powered water pumps were fitted with two pre-combusted 293 mm GF/F filters (Fisher Scientific), which will later be analysed for particulate and dissolved organic carbon. The SAPs was programmed with a delay time and a pump time and then deployed clamped to the CTD array. The volume of water pumped was recorded in UK gallons and converted to litres. Units following analysis will be $\text{g C l}^{-1} \text{h}^{-1}$.

Equipment report: Equipment performed as expected. Initial tests produced some torn filters, but this was rectified by altering the pumping time.

Table 5.3 Stand-alone pump deployment summary

Date	Site	Station	Water depth (m)	Time in water (GMT)	Delay (min)	Pump time (min)	Vol. pumped (l)	Heriot-Watt no.
21/05/12	Mingulay	15	122	11.53	24	30	309	HWU20120521/SAPS/001
22/05/12	Mingulay	23	144	6.16	24	18	259	HWU20120522/SAPS/001
22/05/12	Mingulay	24	144	8.33	24	18	268	HWU20120522/SAPS/002
22/05/12	Mingulay	25	142	1105	24	18	127	HWU20120522/SAPS/003
23/05/12	Mingulay	28	122	0015	24	12		HWU20120523/SAPS/001
23/05/12	Mingulay	29	123	0240	24	18	205	HWU20120523/SAPS/002
23/05/12	Mingulay	30	123	0456	24	18	255	HWU20120523/SAPS/003
24/05/12	Mingulay - Banana	44	142	1138	24	18	268	HWU20120524/SAPS/001
26/05/12	Logachev 1	53	678	0150	42	24	245	HWU20120526/SAPS/001
26/05/12	Logachev 1	54	678	0428	42	24	368	HWU20120526/SAPS/002
28/05/12	Logachev 1	68	574	0549	42	24	355	HWU20120528/SAPS/001
28/05/12	Logachev 1	69	574	0823	42	24	295	HWU20120528/SAPS/002
28/05/12	Logachev 1	73	544	1033	42	24	291	HWU20120528/SAPS/003
03/06/12	Logachev S	114	765	1114	42	24	305	HWU20120603/SAPS/001
03/06/12	Logachev S	116	772	1604	42	24	305	HWU20120603/SAPS/002
03/06/12	Logachev S	118	786	1954	42	24	300	HWU20120603/SAPS/003
04/06/12	Logachev N	119	780	2306	42	24	318	HWU20120604/SAPS/001
04/06/12	Logachev N	121	782	0356	42	24	305	HWU20120604/SAPS/002
04/06/12	Logachev N	123	782	0757	42	24	295	HWU20120604/SAPS/003
05/06/12	Logachev N	133	779	2138	54	24	305	HWU20120605/SAPS/001
05/06/12	Logachev N	134	780	2350	54	24	309	HWU20120605/SAPS/002
06/06/12	Logachev S	141	767	0850	54	24	309	HWU20120606/SAPS/001

5.4 Moving Vessel Profiler (Juan Moreno Navas)

The Moving Vessel Profiler (MVP) mounted in the RRS *James Cook* is the MVP300 system, a self-contained profiling system capable of sampling water column profiles to more of 300 m depth or more depending on vessel speed. The system provides vertical profiles of oceanographic data such as sound velocity, CTD and particle counts. The MVP300 is completely autonomous and can be controlled remotely without the requirement for personnel on deck. The system consists of a single, dual or multi sensor free-fall fish, and integrated winch and hydraulic power unit, towing boom and remotely located user interface controller. The LOPC is a real time plankton counter while being towed in an oceanographic environment and in addition of plankton counter can also record the shape outlines and sizes of particles.

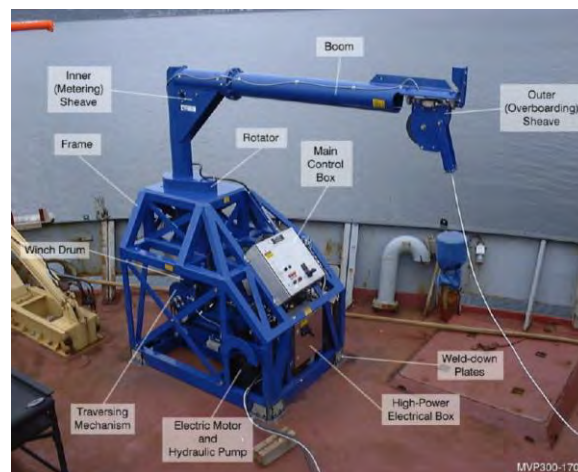

Figure 5.4 Moving Vessel Profiler unit on deck. Image reproduced from Figure 1 in the MVP manual (ODIM BROOK OCEAN).

During the JC073 cruise a multi sensor free fall fish was used with CTD micro sensor (Applied Microsystems Limited), fluorometer (Chelsea Instrument limited, MINITRACCA) and Laser Optical Plankton Counter (ODIM BROOKE OCEAN).

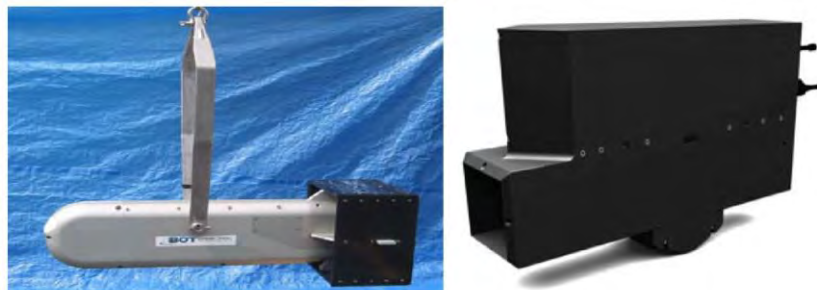

Figure 5.5 Towfish (right) and laser optical plankton counter (LOPC). Images reproduced from the MVP and LOPC manuals (ODIM BROOKE OCEAN).

5.4.1 Deployments

Four MVP deployments were carried out in four areas: Mingulay reef, Logachev Mounds, *Pisces* 9 and MSS. During the MVP transects at Mingulay the depth was controlled by the operator varying the maximum towfish deployments to depths between 50 and 130 m. The maximum water depth during the Logachev Mounds transects was fixed at 450 m. The maximum number of profiles was 69 with a ship speed of 5 knots in all deployments. Table 5.4 summarises the MVP deployments.

Table 5.4. Summary of MVP deployments

Activity No	Start Date	Start Time GMT	Start Lat deg N	Start Lon deg W	End Lat deg N	End Lon Deg W	Event No
MVP01	21/05	14:23:45	56 49.47962	07 23.61209	56.82466	-7.39353	JC073_016_MVP
MVP02	29/05	22:05:00	55 32.53657	15 38.77198	55.54228	-15.6462	JC073_094_MVP
MVP03	01/06	13:00:00	55 29.0917	15 47.72064	55.48486	-15.7953	JC073_112_MVP
MVP04	07/06	07:33:46	57 20.71958	14 43.93508	57.34533	-14.7323	JC073_144_MBES/MVP
MVP05	08/06	00:15:00	57 36.09651	14 30.26385	57.60161	-14.5044	JC073_148_MBES/MVP

The MVP oceanographic data were initially processed within the MVP controller software (v2.380) to produce colour intensity plots. Data were exported to ASCII format. The LOPC software version 1.39 was used for data collection, processing and display.

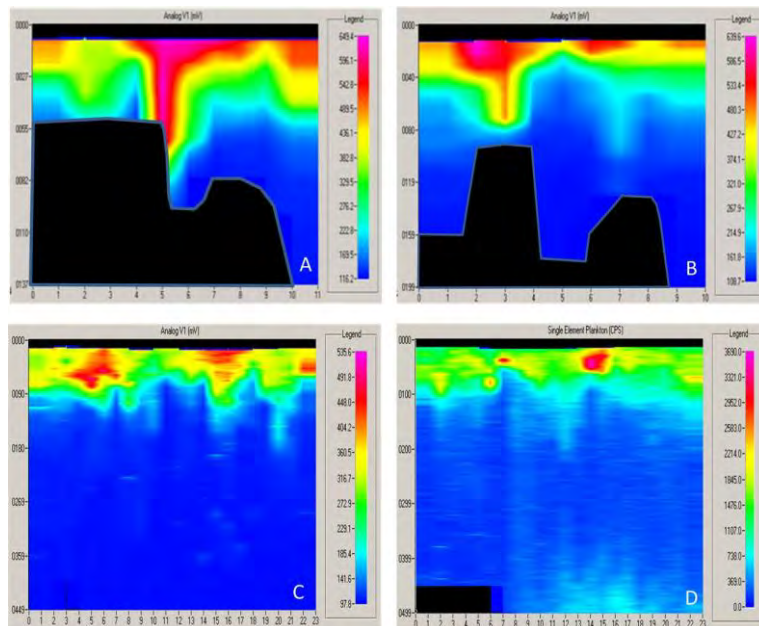

Figure 5.6 Examples of Moving Vessel Profiler raw data. Panels A, B and C show preliminary values of fluorescence (mV) and Panel D shows single element plankton (counts per sec). Data were recorded from several lines across the Mingulay reefs (Panels A and B, event No JC073_16_MVP) and Logachev mounds (Panels C and D, event No JC073_094_MVP).

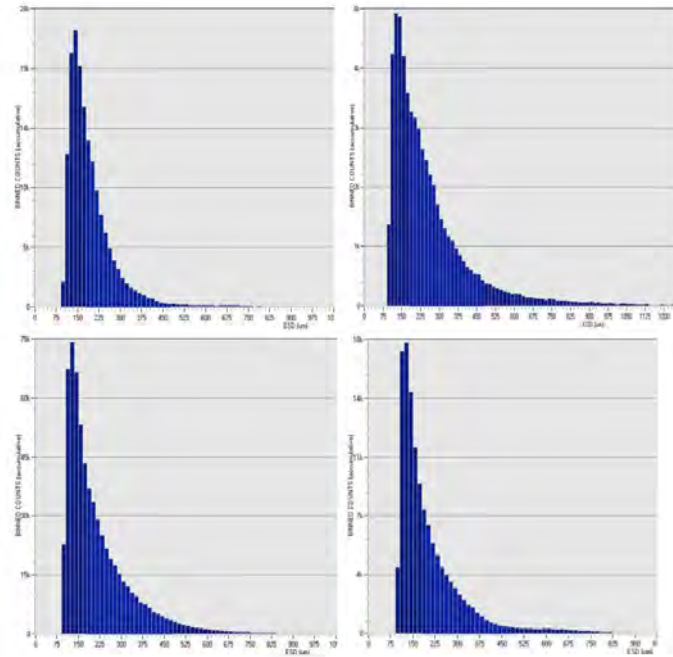

Figure 5.7 Preliminary histograms of the cumulative particle counts of the four MVP deployment lines derived from the laser optical plankton counter (LOPC) across the Mingulay Reefs (Event No JC073_16_MVP).

5.5 Acoustic Doppler Current Velocity (Juan Moreno Navas)

Two vessel-mounted RD Instruments ADCPs (VM-ADCP) were installed on the port drop keel. The 75 kHz Ocean Surveyor (OS75) was positioned in front of the 150 kHz Ocean Surveyor ADCP (OS150). The latter was situated behind a plate and thus roughly 10 cm higher than the OS75 which was aligned with the bottom of the hull. The draft of the ship was 6.9 m. When lowered, the keel extended 2.8 m below the hull. The resulting transceiver depths were 6.9 m and 6.8 m for the OS75 and the OS150 respectively when the keel was retracted, and 9.7 m (OS75) and 9.6 m (OS150) when the keel was lowered. The ADCPs were controlled using the proprietary RDI VmDas software, version 1.42. The software was installed on the ADCP PCs in the main lab. The ADCPs were controlled via VmDas on two separate laptops. The VmDas can be used for data acquisition, archiving, processing, display and reporting. During JC073 the ADCP setup, data logging, preliminary screening and mapping of beam data onto Earth coordinates were done with VmDas. The primary visualization was performed with WINADCP and the final processing will be performed using a set of Matlab routines.

General settings: During JC073 we ran both the OS75 and OS150 in Narrowband mode with bottom tracking. The bin size for the OS150 was 4 m, number of bins was set to 50, and the blanking distance was again 6 m. The time between pings was 2 seconds (to be set in VmDas). For the OS75, profiling was set to 60 bins with a bin depth of 8 m and a blanking distance at the surface of 8 m shallow waters (Hebrides) and 16 m bins depth with 60 bins during the rest of the

cruise. The time between pings was 2 seconds. During JC073, both ADCPs were used to gather data throughout most of the cruise.

ADCP setup tab:

ADCP setup from file (enter the required command file) time between ping ensembles: 2 seconds

Nav tab:

NMEA Ship Position (GGA) Source: Enable, choose NMEA2 from drop down menu
disable NMEA Ship Speed (VTG) Source

Transform tab:

Heading Source: NMEA HDA, Fixed Heading set to 0

Tilt Source: Fixed Tilts 0 Fixed Pitch, 0 Fixed Roll (don't enable tilt correction)

Heading Sensor Magnetic/Electrical Corrections: 0 EV: Primary Heading Error, 0 EV Backup

Heading Error disable all other corrections

Averaging tab:

check Temporal

The STA interval was set to 120 seconds, LTA to 600 seconds

Profile Ping Normalisation Reference Layer was enabled and set to start bin = 3, end bin = 10

Output data format:

The filename structure followed this format ADCPxx_BTon_yyyyyy.END, where xx is the ADCP (75 or 150), yyyyyy is a number automatically set by VmDas starting at 0 and increasing when the file size becomes larger than max size (100MB) and a new file is created. END is the filename extension. The following list shows all the different file types that were created during JC073:

- ENR: binary; raw ADCP data file.
- STA: binary; average ADCP data, short time period specified with VmDas.
- LTA: binary; average ADCP data, long time period specified with VmDas.
- ENS: binary; ADCP data after screening for RSSI and correlation. VmDas or adjusted by user, and navigation data from. NMS file.
- ENX: binary; ADCP single-ping data and navigation data, after having been bin-mapped, transformed to Earth coordinates and screened for error velocity, vertical velocity and false targets.
- N1R: ASCII text; raw NMEA data.
- N2R: ASCII text; raw NMEA data.
- NMS: binary; navigation data after screening and pre-averaging.
- VMO: ASCII text; option setting used for collection the data.
- LOG: ASCII text; all logging output and error messages.

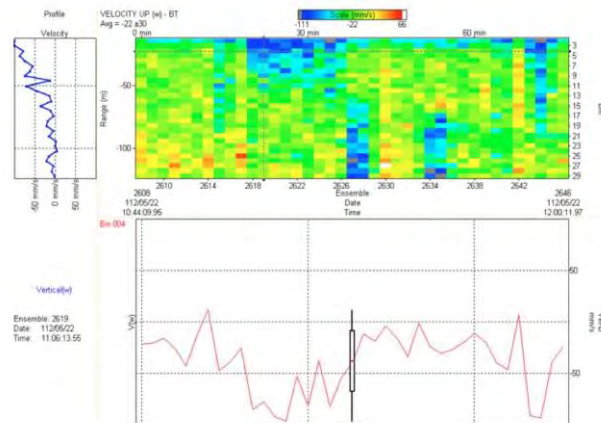

Figure 5.8 Example of time series (22/05/2012) and profiles from WINDADCP software showing vertical current speed values (mm/s) recorded during a survey above the Mingulay Reef Complex.

Comments:

- VmDas software controlling the OS75 crashed on 27/05/2012 and 5/06/2012 and for the OS150 crashed on 5/06/2012 and 6/06/2012
- The OS75 was set up with a new setting for deeper waters on the 27/05/2012
- The OS75 was disconnected during the multibeam echosounder surveys
- During 5 to 8 of May the logging was intermittent due to a variety of reasons including multibeam echosounder surveys and software failure.

5.6 Acoustic Surveys (Veerle Huvenne)

5.6.1 Introduction & Rationale

Throughout JC073 several acoustic surveys were carried out, using either the shipboard systems or a specific Reson7125 multibeam echosounder on the ROV. They are summarised in Table 5.5. The rationale behind the surveys ranged from reconnaissance mapping (Hellisay, Logachev1), work during adverse weather (Logachev2) to actual dedicated habitat mapping (Logachev ROV, *Pisces* 9, NW Rockall Bank, Mingulay ROV, Mingulay EM710). Although each of the surveys provides supporting spatial information for the experimental and observational work of this cruise, the dedicated habitat mapping surveys will be incorporated within the European Research Council's CODEMAP project. The main aim CODEMAP is to develop an integrated, robust and fully 3-dimensional methodology to map complex deep-sea habitats, to quantify their heterogeneity and to test if heterogeneity measures derived at different scales reflect epibenthic megafauna biodiversity. The project focuses on submarine canyons, but other complex deep-sea environments (such as cold-water coral reefs) are targeted as well.

The motivation behind this work is the fact that human impact on the deep ocean is rapidly increasing, with largely unknown consequences. Effective management and conservation, based

on ecosystem approaches, is hampered by our poor understanding of the deep-sea. Measuring biodiversity, the main indicator of ecosystem status and functioning, is a major challenge in deep water: traditional sampling schemes are expensive and time-consuming, and their limited coverage makes it difficult to relate the results to regional patterns. Complex deep-sea environments are especially problematic: ecosystem hotspots such as canyons or cold-water coral reefs contain true 3D morphology that cannot be surveyed with conventional techniques. By evaluating habitat heterogeneity as a proxy for biodiversity, and by developing quantitative correlations between data collected at a variety of scales, CODEMAP aims to provide a substantial contribution towards the sustainable management of our deep seas.

Table 5.5 Acoustic Surveys

Site	Date	Event Gear Code	Final sample number	Comments
Hellisay	20/05/12	EM120 EM710 SBP	JC073_005_MBES JC073_005_MBES/710 JC073_005_MBES/SBP	Exploratory mapping to search for <i>Lophelia</i> reef occurrence
Mingulay1	23/05/12	SBP	JC073_031_SBP	SBP120 survey to find good coring sites
Logachev1	26/05/12	EM120 SBP	JC073_055_MBES JC073_055_MBES/SBP	Short survey of Logachev area to find coring stations
Logachev1	26/05/12	ROV	JC073_057_ROV11	ROV dive for multibeam mapping - no OFOP record
Logachev2	02/06/12	EM120 SBP	JC073_113_MBES JC073_113_MBES/SBP	Multibeam and SBP survey to cover bad weather period
<i>Pisces</i> 9	07/06/12	EM120 EM710 SBP	JC073_144_MBES JC073_144_MBES/710 JC073_144_MBES/SBP	Swath survey and simultaneous MVP survey
NW Rockall Bank	08/06/12	EM120 EM710 SBP	JC073_148_MBES JC073_148_MBES/710 JC073_148_MBES/SBP	Multibeam and MVP survey from <i>Pisces</i> 9 site to MSS3 (NW Rockall Bank protected area - JC060 Autosub sidescan patch)
Mingulay	12/06/12	ROV	JC073_177_ROV39	ROV dive for multibeam mapping - no OFOP record
Mingulay	13/06/12	EM710 SBP	JC073_178_MBES/710 JC073_178_MBES/SBP	Multibeam survey for habitat mapping
Mingulay	14/06/12	EM710 SBP	JC073_181_MBES/710 JC073_181_MBES/SBP	Filling in gaps from previous survey & extension

5.6.2 Methods and equipment performance

Deep-water multibeam: For surveys in water depths of 200 m or more, the shipboard Simrad EM120 system was used, with its standard settings. Data acquisition was through the Simrad software SIS. Before each of the surveys, a sound velocity profile was acquired, and entered in the SIS software to ensure the most correct data acquisition. The system performed very well in calm weather conditions (surveys around Hellisay and Logachev1), but had more trouble during later surveys. A calibration exercise was carried out at the start of the first survey (Hellisay), and it was found that the system had a pitch offset of -3° . This value was incorporated during the processing stage (see below).

Shallow-water multibeam: For surveys in waters up to 500 m, the aim was to use the shipboard Simrad EM710. Due to its higher frequency, it is supposed to provide better resolution and backscatter data than the EM120 in those water depths. However, during the first survey (Hellisay), the EM710 recorded very noisy data, and it was decided to use the EM120 data instead to create the bathymetric map of the area. Only later during the cruise (*Pisces 9* survey), it was established that one of the system settings had prevented the multibeam from acquiring good quality data (i.e. the 'mammal protection' setting was on, preventing the system from using sound pulses at the appropriate amplitude). This was then rectified and good quality data were collected after that. No further calibration exercises were carried out with the EM710, but the overlap between lines in the survey on NW Rockall Bank meant that a roll offset of -0.55° could be established. This was corrected for during the processing. All of the EM710 surveys were carried out with the dropkeel out, to make sure any potential noise caused by bubble streams under the hull was minimised.

Sub-bottom profiler: During each of the shipboard multibeam surveys, and in addition on one occasion at the start of the cruise, the shipboard SBP120 system was used to obtain information about the seabed nature in terms of sediment depth (guidance for coring operations) and morphology. The system used the depth below the ship detected with the EM120 multibeam as a guidance for its bottom tracking algorithms. Standard settings were used, and provided good quality profiles.

ROV-mounted multibeam: In order to obtain high-resolution maps of the coral systems under study, a Reson 7125 multibeam system was installed on the *Holland-1* ROV. The Reson7125 is a dual frequency system with both a 200 and 400 kHz transducer, and 512 beams. Data recording was carried out through the Reson software PDS2000, and was supported by the inputs of the ROV depth sensor (Digiquartz, measuring depth in dbar), MRU (Phins), Doppler navigation and USBL navigation (Sonardyne). The relative offsets of each of these pieces of equipment vs. a common reference point on the vehicle (middle front of the ROV, top of the bottom bar) are listed in Table 2. An estimate of the sound velocity was obtained in real time from the ROV-borne CTD.

Table 5.6 Offsets of the ROV multibeam and attitude sensors

	X (m)	Y (m)	Z (m)
Digiquartz	-0.370	-2.280	0.400
Phins	0.600	-1.210	0.120
Reson 7125	-0.600	-0.220	-0.105
Doppler	0.590	-1.740	-0.040
USBL	0.00	-3.100	1.450

The ROV multibeam surveys were initially carried out at an average speed of 0.4 kn, but during the second survey a speed of 0.5 kn was used to allow a larger coverage in the same time frame. The ROV height above the bottom was kept at ca. 25 to 30 m, as far as possible. Major problems were encountered with the navigation during the first multibeam dive (Logachev ROV), which were caused by the Doppler system not being calibrated correctly. The incoming Doppler data were used within the Kalman filter of the USBL navigation, making the ROV apparently shift off track, and affecting the guidance for the pilots in the Helmsman display. For the second survey (Mingulay ROV), a different set-up was chosen. The Doppler information was no longer fed into PDS2000, but was diverted to the software DVLNAV, which provided a plot of both USBL and Doppler position against a .jpg background map of the area, in addition to several other parameters derived from the system (COG, heading, SOG, vertical velocity etc.). Those data were also logged in a separate logfile. Once the Doppler system was properly calibrated, it provided a stable navigation system for the pilots to fly the ROV during the survey. The PDS2000 Helmsman display, on the other hand, was not so reliable as the system seemed to buffer data and only showed the ROV progress in ‘jumps’.

A multibeam calibration exercise was included in each of the ROV multibeam surveys, with varying results. The outcome was incorporated during the processing stage (see below).

A major problem occurred at the start of the second survey: the system lost uplink communication with both transducers. Following consultation with our Reson contact, a firmware update was installed which repaired the problem. After that the dive and the survey could continue without trouble.

5.6.3 Acoustic Data Processing

Shipboard multibeam bathymetry: Processing of the EM120 and EM710 data were carried out in CARIS HIPS & SIPS v.7, although the calibration was performed under the IFREMER software CARAIBES v.3.6, because its calibration function is more user-friendly. The survey lines were loaded into different projects for the different areas, the navigation and attitude data were checked (but were all of good quality) and for initial shipboard processing a zero tide was applied. The data were gridded using a BASE surface (Bathymetry Associated with Statistical

Error), and initial data cleaning was carried out under a combination of the Swath Editor and the Subset Editor. The grids were then exported to ASCII txt files and imported into ArcGIS to support further cruise planning.

ROV-borne multibeam bathymetry processing: Processing of the Reson ROV-borne multibeam data was initially attempted in Caris HIPS & SIPS, but was eventually carried out in CARAIBES as this allows the user closer access to the actual raw data. It became apparent very quickly that the first dataset had a few problems that needed rectification. The navigation included the Doppler steering, and therefore showed a large number of errors and a sort of saw-tooth pattern. This was replaced by USBL navigation recorded directly under the Sonardyne software. The second problem related to the ROV depth sensor, which appeared to have stalled regularly, therefore compromising the calculation of the depth of entire sections of several pings. Careful cleaning and interpolation of the depth records certainly improved the data, but further processing will be necessary to obtain a good map. Initial results are presented in Fig. 5.9. The second dataset was only collected at the very end of the cruise, and apart from an initial quality check (merely to establish that all the data had been recorded correctly), no further processing was carried out on board.

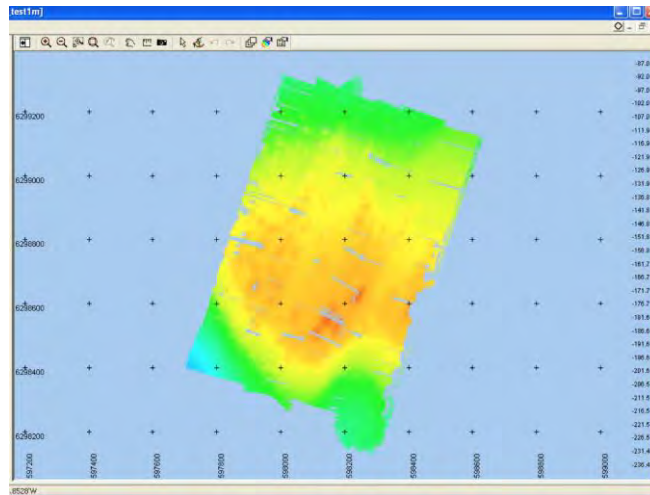

Figure 5.9 Screenshot of PDS2000 software with datagrid of the Mingulay ROV multibeam echosounder survey. See corresponding ROV dive track 39 in Appendix 4.

5.6.4 Acoustic survey future analysis

Further refinement of the bathymetry processing, both of the shipboard and the ROV-based surveys will be carried out at NOC, using a combination of the Caris, Caribes and MBSYSTEM software. Backscatter processing will be carried out at NOC, based upon the in-house software PRISM. The resulting maps will be loaded into ArcGIS and combined with video interpretation

records and sampling information. This will form the basis for further quantitative analysis and habitat mapping under the CODEMAP project.

5.7 SPI camera (Silvana Birchenough)

The SPI camera works like an inverted periscope, which has a wedge-shaped prism with a plexi-glass faceplate and an internal light provided by a flash strobe (Figure 5.10). The back of the prism has a mirror mounted at a 45° angle, which reflects the image of the sediment-water interface at the faceplate up to the camera.

The wedge-shaped prism enters the bottom and is driven into the sediment by its weight. A "passive" hydraulic piston ensures that the prism enters the bottom slowly and does not disturb the sediment-water interface. A mass of 250 kg is used aid penetration. On impact with the bottom, a trigger activates a time-delay on the camera shutter release and a photograph is taken when the prism comes to rest. For JC073 the initial delay was set to 15s with a second photo being taken after a further 15s (Figure 2).

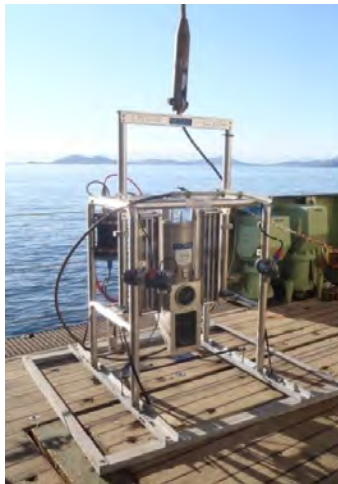

Figure 5.10 Image showing the Cefas Sediment Profile Camera (SPI) including a camera and light attached to the frame for acquiring plan view images.

The SPI system used on JC073 was supplied by Cefas. It was an Ocean Imaging Systems Inc. (Massachusetts, USA) SPI system based around a Nikon D90 digital SLR, which has 11Mpixel resolution. The system has an additional video camera which is set to give a real time image of the seabed. This allows the operator to be selective when deploying the SPI, which both enables better science and protects the camera from damage. The additional video camera is a Bowtech L3C 550c colour with a SeaLED light used for illumination.

The SPI system was deployed on the RRS *James Cook* Deep Tow Cable which is approximately 7000 m long. It is an armoured cable with 3 power conductors and 3 single mode fibre optics. A

Fibrelink 3621A was used for transmission and reception of the video signal over one of the fibres.

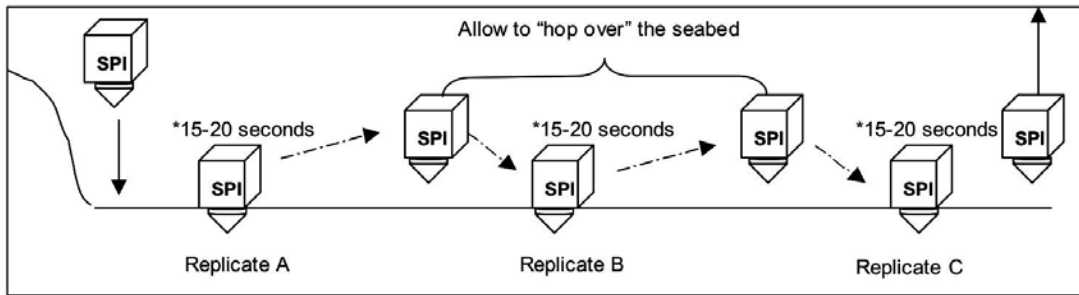

Figure 5.11 Schematic representation of the SPI deployment and collection of 3-5 replicate images.*time allowed for prism penetration at each site.

5.8 Box coring

Two different box corers were available, the SMBA Box Corer and the NIOZ Box Corer. Although very similar, they have slightly different triggering mechanisms. The **SMBA Box Corer** consists of a gimbaled sample box and spade assembly, where the box is lowered onto the seabed and the sample bucket is forced into the sediment by the weight of the corer. As the SMBA Box Corer is slowly pulled out of the sediment, a mechanism allows the spade to swing below the sample box, sealing in the sediment. Simultaneously, spring loaded flaps above the sample box close to prevent the sample being disturbed during recovery. The **NIOZ Box Corer** works on a similar basis as the SMBA Box Corer, with the difference that two spades are operated from either side of the sample box. This corer is also heavier than the SMBA Corer.



Figure 5.12 NIOZ Box Corer (left), photo: Murray Roberts. SMBA Box Corer (right), photo: Rosanna Milligan

5.8.1 Box Coring at the Mingulay Reef Complex

Team: Claudia Alt, Silvana Birchnough, Nigel Lyman, Karl Attard

Objective: The objective at this site was to collect undisturbed sediment samples for a bioturbation experiment onboard the RRS *James Cook*. Sample sites were initially chosen along a transect line heading vertically away from the reef system and coinciding with one of the SPI transects. Locations were chosen based on available bathymetry data and SPI images. The aim was to create a dataset, combining *in situ* bioturbation rate (Claudia Alt); SPI image analyses (Silvana Birchnough & Nigel Lyman); total oxygen flux, oxygen micro profiles (to estimate the faunal contribution) and dissolved organic carbon (Karl Attard).

Unfortunately, there were no successful deployments at the site and the project had to be abandoned. It was not possible to collect a similar dataset at the Logachev site, as no suitable sediment was found close to the coral carbonate mounds. The closest potential sites exceeded 800 m in depth. Such a pressure difference would not have allowed for a realistic assessment of bioturbation rates, even if animals had still been alive.

No box core logsheets for these deployments were retained at sea.

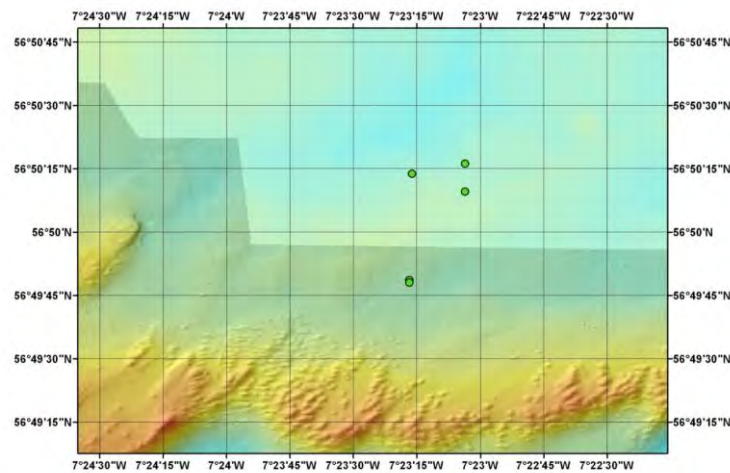

Figure 5.13: Map of the Mingulay area showing locations of box cores, courtesy of Juan Moreno Navas

Table 5.7 Box Corer stations at Mingulay with notes on deployment success

Station	Latitude	Longitude	Comment
JC073/017	56°49.81'N	07°23.28'W	SMBA Box Corer Fired but rock wedged into spade, preventing sealing, drained all sediment, and damaged the box
JC073/018	56°49.80'N	07°23.28'W	SMBA Box Corer Fired but rock wedged into spade, preventing sealing, drained all sediment, and damaged the box
JC073/019	56°49.80'N	07°23.28'W	SMBA Box Corer Fired but rock wedged into spade, preventing sealing, drained all sediment, and damaged the box
JC073/020	56°50.16'N	07°23.06'W	SMBA Box Corer Triggering mechanism did not fire. The assumption was that the sediment was not soft enough, resulting in a change of corer
JC073/021	56°50.27'N	07°23.06'W	NIOZ Box Corer Triggering mechanism did not fire
JC073/022	56°50.23'N	07°23.27'W	NIOZ Box Corer Triggering mechanism fired, but did not retrieve any samples
JC073/048	56°48.05'N	07°26.72'W	SMBA Box Corer Triggering mechanism did not fire
JC073/049	56°48.05'N	07°26.72'W	SMBA Box Corer Triggering mechanism did not fire
JC073/050	56°48.05'N	07°26.70'W	SMBA Box Corer Triggering mechanism did not fire
JC073/051	56°48.05'N	07°26.70'W	NIOZ Box Corer Triggering mechanism did fire, but had several rocks wedged into the mechanisms, preventing the sealing of the corer

5.8.2 Box Coring at the Logachev Mounds

Team: Claudia Alt, Silvana Birchenough, Penelope Donohue, Lisette Victorero Gonzalez, Nigel Lyman, Laura Wicks, Janina Büscher, Juan Moreno-Navas, Sebastian Hennige, Veerle Huvenne, Anne Cotton, Rosanna Milligan, Rowan Byrne, Geoffrey Cook, Karl Attard.

Objective: The aim for box coring at the Logachev Mounds was to collect coral frameworks for biodiversity analyses. The **NIOZ box corer** was used for this, as it is better suited for sampling in heterogeneous sediment.

Processing: The content of the box corers were sieved through 1 mm and 0.5 mm sieves. Samples were stored according to size fraction and fixed in formalin. Deck photographs of the box cores are given in Appendix 3.

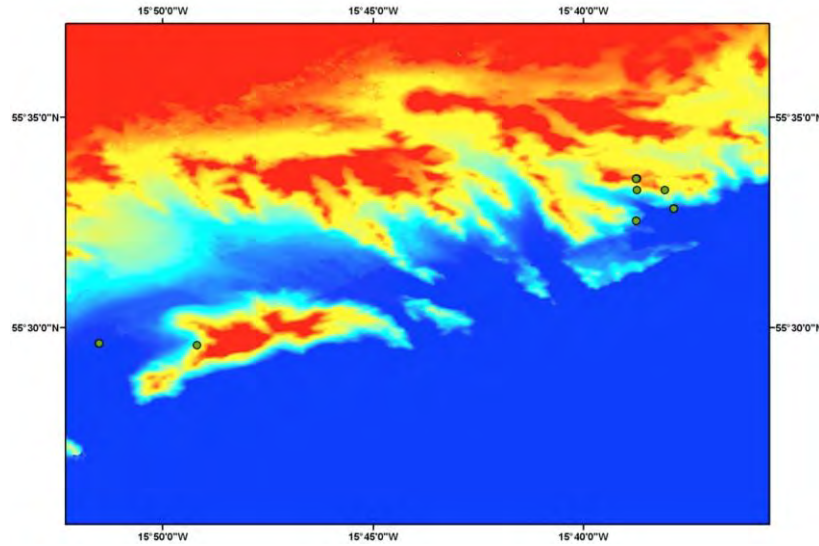

Figure 5.14 Map of the Logachev coral carbonate mound sampling area, courtesy of Juan Moreno Navas

Table 5.8 Box Corer stations at Logachev Mounds with notes on deployment success.

Station	Depth	Latitude	Longitude	Comment
JC073/077	874 m	55°32.84'N	15°37.85'W	Sample collected
JC073/078	877 m	55°32.83'N	15°37.85'W	Sample collected
JC073/079	874 m	55°32.83'N	15°37.85'W	Sample collected
JC073/080	697 m	55°33.27'N	15°38.72'W	Triggering mechanism did not fire – no sample
JC073/081	589 m	55°33.55'N	15°38.72'W	Triggering mechanism did not fire – no sample
JC073/082	588 m	55°33.55'N	15°38.72'W	Coral Framework collected
JC073/083	595 m	55°32.55'N	15°38.74'W	Triggering mechanism did not fire – no sample
JC073/084	589 m	55°33.55'N	15°38.74'W	Triggering mechanism did not fire – no sample
JC073/085	590 m	55°32.54'N	15°38.74'W	Triggering mechanism did not fire – no sample
JC073/086	595 m	55°33.54'N	15°38.74'W	Triggering mechanism did not fire – no sample
JC073/089	590 m	55°33.54'N	15°38.74'W	Triggering mechanism did not fire – no sample
JC073/090	590 m	55°33.54'N	15°38.74'W	Fired, but no sample
JC073/091	661 m	55°33.27'N	15°38.06'W	Full Box Core recovered
JC073/090	659 m	55°33.27'N	15°38.06'W	Full Box Core recovered
JC073/103	884 m	55°29.63'N	15°51.53'W	Fired, but no sample
JC073/104	884 m	55°29.63'N	15°51.53'W	Fired, but no sample
JC073/105	883 m	55°29.63'N	15°51.52'W	Fired, but no sample. Box got damaged quite badly by catching a large rock
JC073/106	696 m	55°29.58'N	15°49.19'W	Small sample with mainly coral fragments and only little sediment

JC073/107	693 m	55°29.58'N	15°49.19'W	About half full box
JC073/108	702 m	55°29.58'N	15°49.19'W	no sample, due to winch issues
JC073/109	696 m	55°29.58'N	15°49.19'W	Triggering mechanism did not fire – no sample
JC073/110	694 m	55°29.58'N	15°49.19'W	Very little sample

5.8.3 Box Core Sampling at the Hebrides slope

Team: Claudia Alt, Silvana Birchenough, Penelope Donohue, Lisette Victorero Gonzalez, Nigel Lyman, Laura Wicks, Janina Büscher, Sarah Fitzek, Juan Moreno-Navas, Sebastian Hennige, Veerle Huvenne, Anne Cotton, Rosanna Milligan, Rowan Byrne, Geoffrey Cook, Karl Attard, Georgios Kazanidis, John Polanski, Covadonga Orejas.

Objective: The aim of the survey at the Hebrides slope was to revisit a historic sampling site from the 1980s and to monitor the temporal change that occurred over the past 30 years. The SMBA box corer had originally been used for this area and was therefore chosen initially, but after encountering some problems the box corer was changed to the NIOZ Box Corer.

Processing: The samples were sliced into depths 0-2 cm and 2-10 cm, the remainder of the core was discarded. The 0 to 2 cm were put into formalin in order to toughen the macrofauna. The 2-10 cm were sieved straight away using 1 and 0.5 mm sieves, while the upper layer was sieved after the fauna had time to toughen, with the same size fractions.

Table 5.9 Box Corer stations at Hebrides slope with notes on deployment success.

Station	Depth	Latitude	Longitude	Comment
JC073/154	1803 m	56°30.88' N	09°58.72'W	SMBA Box Corer Successful core, sieved for 0-2 cm, and 2-10 cm, with 1 and 0.5 mm
JC073/156	1804 m	56°30.89' N	09°58.64'W	SMBA Box Corer Wire got tangled up in core, no sample
JC073/157	1803 m	56°30.89' N	09°58.64'W	SMBA Box Corer Fired, very disturbed sample that had to be discarded, because the box didn't seal and drained out most of the sediment
JC073/158	1803 m	56°30.89' N	09°58.64'W	SMBA Box Corer Box core successful although a little drained.
JC073/159	1806 m	56°30.89' N	09°58.64'W	SMBA Box Corer Box corer successful, although a little drained.
JC073/162	1419 m	56°29.94' N	09°36.37'W	NIOZ Box Corer box core did not fire and wire got tangled
JC073/163	1418 m	56°29.94' N	09°36.38'W	NIOZ Box Corer

				Perfect box core
JC073/164	1418 m	56°29.94' N	09°36.38'W	NIOZ Box Corer Perfect box core
JC073/166	1801 m	56°30.89' N	09°58.64'W	NIOZ Box Corer Successful core
JC073/167	1421 m	56°29.95' N	09°36.49'W	NIOZ Box Corer Successful core
JC073/168	1421 m	56°29.95' N	09°36.49'W	NIOZ Box Corer Successful core
JC073/169	1422 m	56°29.95' N	09°36.49'W	NIOZ Box Corer Successful core
JC073/170	1029 m	56°28.93' N	09°19.15'W	NIOZ Box Corer Successful core
JC073/171	1028 m	56°28.92' N	09°19.15'W	NIOZ Box Corer Successful core
JC073/172	1027 m	56°28.92' N	09°19.15'W	NIOZ Box Corer Successful core
JC073/173	1027 m	56°28.92' N	09°19.15'W	NIOZ Box Corer Successful core

5.9 Gravity coring (Claudia Alt, Veerle Huvenne)

Team: Claudia Alt, Veerle Huvenne, Lisette Victorero Gonzalez, Silvana Birchenough

The gravity corer on JC073 consisted of a weight with steel tube sections attached to it. The weight can vary 100 to 1000 kg, depending on the type of sediment that needs to be penetrated. The length of the sample tube is also selected based upon sediment type. The gravity corer is lowered into the sediment at a set speed, and once retrieved the liner encasing the sample is removed and cut into sections. Three sites were chosen at the Mingulay and the Logachev complexes, based on multibeam and bottom profiler data. For the current study the sample tubes used ranged between 2 and 3 m length. Once gravity cores were recovered, the inner lining was cut every meter, or less where less sediment had been caught inside the liner. The samples were labelled and stored in the cooling container, together with the core catcher.



Figure 5.15 Gravity corer being deployed during JC073.

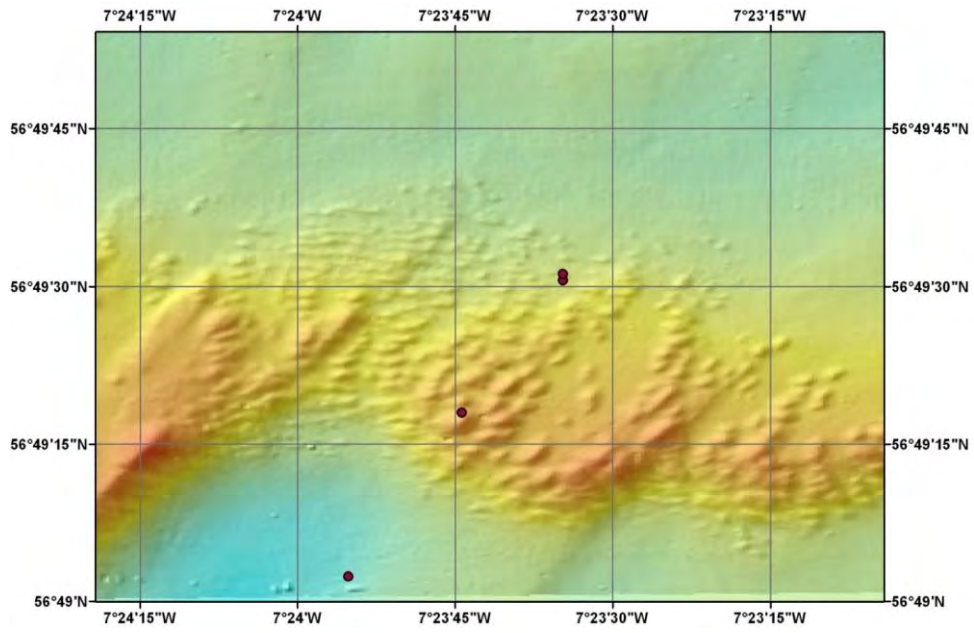

Figure 5.16 Gravity core positions at Mingulay

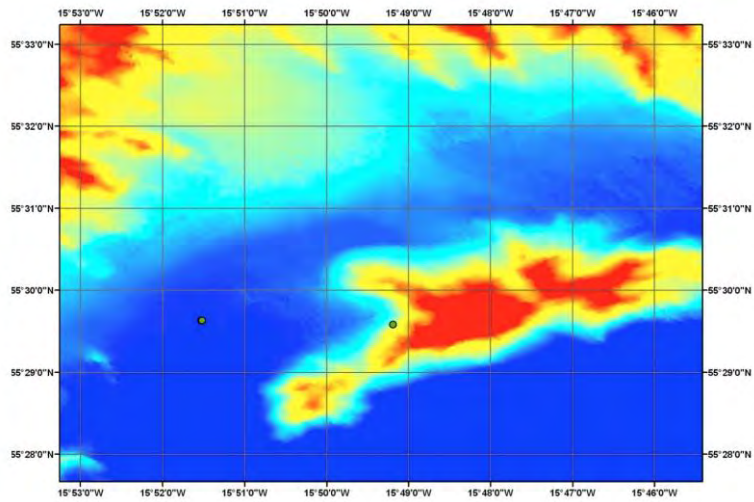

Figure 5.17 Gravity core positions at Logachev Mounds

Table 5.10 Stations for the gravity core with notes on deployment success.

Station	Date	Latitude	Longitude	Area	Comment
JC073/032	23 rd May	56°49.04'N	07°23.92'W	Mingulay	Core over-penetrated; about 1.75 m
JC073/033	23 rd May	56°49.04'N	07°23.92'W	Mingulay	Disturbed, corer had to be hammered out, About 1.60 m
JC073/034	23 rd May	56°49.30'N	07°23.74'W	Mingulay	About 0.5 m sediment
JC073/035	23 rd May	56°49.51'N	07°23.58'W	Mingulay	About 1 m sediment
JC073/036	23 rd May	56°49.52'N	07°23.58'W	Mingulay	About 1 m sediment
JC073/037	23 rd May	56°49.04'N	07°23.92'W	Mingulay	About 2.5 m sediment
JC073/063	28 th May	55°33.66'N	15°39.32'W	Logachev	Core failed, with only a little bit of gravel at the catcher
JC073/064	28 th May	55°33.66'N	15°39.32'W	Logachev	
JC073/065	28 th May	55°33.32'N	15°39.32'W	Logachev	Just under 1 m
JC073/066	28 th May	55°33.32'N	15°39.32'W	Logachev	About 1.60 m
JC073/067	28 th May	55°33.66'N	15°39.32'W	Logachev	Unsuccessful with a few coral fragments

5.10 Spreaders (Georgios Kazanidis, John Polanski)

Spreaders are used for *in situ* incubation studies and are normally deployed on soft sediment. The spreaders consist of an acrylic cylinder together with an acetyl lid on which is mounted an ROV grab-handle and combined algae injector/lid separation mechanism. In previous cruises the spreaders have usually been transported to the seabed using an elevator, but an elevator was not available on JC073 so the spreaders were carried to the seabed on the *Holland-1* ROV.

Deployment on coral debris from the ROV raised a number of problems and their use was ultimately unsuccessful. Both the cylinder and lid had to be reduced in size on all three spreaders before deployment due to restrictions in the bio-box dimensions on the ROV for recovery. Also the spreader cylinder and lid had to be able to separate in order to fit in the bio-box. On transit to the sea floor they were mounted on the ROV tool tray.

On the first deployment the spreader was placed over a suitable sponge but was unstable as the cylinder could not penetrate the coral debris. This, combined with a high current in this area, resulted in it toppling over before any further operations could be carried out. The consensus was that the spreader's centre of gravity needed to be lowered. On recovery ~2 kg of lead strips were placed around the base of the cylinder, just above the collar which was 2.5 cm from the base. On the second deployment the additional weight placed too much strain on the bungee

cords and the lid separated from the cylinder while being moved through the water by the ROV arm and could not be repositioned. After this the deployment was abandoned and the ROV returned to the surface.

Concluding, for *in situ* incubations on sponges in this type of terrain, a redesigned spreader could be constructed, that would be effective, especially considering the valuable first-hand experience gained.

5.11 Eddy lander

A full report including sensor details, settings and initial results is provided in Section 6.7.

5.12 Moorings

Two single point current meter moorings were deployed during JC073, one just to the north of Area 01 (Roberts *et al.* 2005) at Mingulay on 24 May and one within the Logachev Mounds on 26 May. The Logachev Mound mooring was recovered during the cruise on 5 June but the Mingulay mooring was left in place for recovery in spring/early summer of 2013. Each mooring consisted of a 350 kg anchor weight, 5 m chain, acoustic release, 3 Benthos glass sphere floats, 5 m chain, an Aanderaa 11 Recording Current Meter, 4 Benthos glass sphere floats and a 15 m rope pick-up line with a single Benthos glass sphere float. The current meters were therefore deployed 15 m above the seabed.

5.13 Geographic Information System

All spatial data were mapped using Geographic Information System (ESRI, v9.3) projects. The GIS projects were organised by site (Mingulay, Logachev, Pisces/MSS, Hebrides Terrace Seamount) and are available with the electronic records from JC073. These projects were used to generate the maps and ROV track plots in this report.

6. Initial results & further analysis planned

6.1 Habitat survey & sampling

Track plots for each ROV dive are given in Appendix 4. During each dive, whenever sampling occurred, the time, sampling method (claw or suction sampler) and designated receptacle were noted on logsheets and on the OFOP electronic dive log. Upon return to the surface, buckets filled with seawater were taken to the ROV to offload live coral samples into individual buckets. The live corals were then placed in labelled baskets in hangar tanks so colonies could be traced back to the locations sampled. Other samples were preserved as needed (formalin-fixed, ethanol-fixed, frozen or dried). Sampling events are recorded alongside station data in Appendix 1.

6.2 Ship-board ocean acidification experiments (Janina Büscher, Rowan Byrne, Penelope Donohue, Sebastian Hennige, Lissette Victorero, Laura Wicks)

Ocean acidification will affect the availability of carbonate ions that form the skeletal structures of many marine organisms via calcification. Cold-water corals have large and robust calcium carbonate (CaCO_3) skeletons that form complex three-dimensional structures which act as habitats for more than 1300 species (Roberts *et al.* 2006). Many cold-water coral habitats are found at high latitudes and deeper depths, which exhibit lower saturation state of calcium carbonate (Guinotte *et al.* 2006). However, it is anticipated that more than 70% of the cold-water coral bioherms known today will be exposed to waters undersaturated with respect to aragonite by the end of the century (Guinotte *et al.* 2006). Therefore, not only might calcification of cold-water corals be hampered but the crucial balance between processes that promote reef framework growth and processes that degrade the structure (bioerosion and dissolution) may be altered.

To assess the effect of future warming and ocean acidification on cold-water corals, live *Lophelia pertusa* colonies were collected from the Mingulay Reef Complex and the Logachev Mounds. Additionally, *Madrepora oculata* was collected from the Logachev mounds. Fragments of each species were used in short-term OA and warming experiments during the cruise, with various physiological measurements taken at set time points. The Heriot-Watt University (HWU) experiments ran for 21 days with *L. pertusa* from Mingulay (with a time-point for measurements after 9 days), 13 days for *M. oculata* from Logachev, and 9 days for *L. pertusa* from Logachev). Colonies of *Lophelia pertusa* from the Mingulay Reef Complex were transported to HWU for additional experiments. The Glasgow University experiments ran for 21 days with *L. pertusa* from Mingulay (with time point measurements after 7, 10 and 14 days) and 14 days with *L. pertusa* from Logachev (with time points measurements after 10 days).

Further physiological analyses by Janina Büscher (GEOMAR) encompassed fitness (RNA/DNA ratio) and respiration measurements (oxygen consumption) of *Lophelia pertusa* samples incubated at different experimental conditions.

In addition, the NIOZ box core collected specimens of an unknown species of solitary cold-water coral. Due to their good condition, baseline physiological measurements were taken and their physiological response to warming examined.

6.2.1 Coral physiology, proteomics & skeletal analysis (Janina Büscher, Penelope Donohue, Sebastian Hennige, Laura Wicks)

Like any stressor, the impact of ocean acidification on benthic organisms may be shown in different components of their energy budget, from energy intake and metabolism, through to calcification and reproductive output. Knowledge of organism-level responses is essential for understanding how stressors cause adverse biological effects, how a population will respond, and the strategies adopted by organisms to tolerate stress. To this end, we examined various parameters of the energy budget of two cold-water corals, and how they changed in response to OA and warming over a 9-21 day period.

Our specific aims were to:

1. Assess changes in the carbon budget and fitness of *Lophelia pertusa* from the Mingulay Reef Complex in response to OA and warming.
2. Compare changes in respiration and calcification in *L. pertusa* from a shallow and deep site, in response to OA and warming.
3. Assess changes in the respiration and calcification of *Madrepora oculata* in response to OA and warming.
4. Compare respiration and calcification in *L. pertusa* from different depths, and corresponding pH levels.

All living organisms respond to environmental changes through changes in the expression of multiple genes and proteins. These on-going anthropogenic environmental changes (including OA and rising seawater temperatures) represent additional environmental stimuli which may induce expression changes in marine organisms. The proteomics studies during JC073 examined how OA and elevated temperature might have a synergistic effect on the molecular physiology of *L. pertusa* and to highlight the importance of using a systems based approach to identify key physiological processes within marine organisms that will be impacted by global climate change.

The proteomics work was carried out by the University of Glasgow (UG), in collaboration with the team from Heriot Watt University (HWU). Specific aims investigated:

1. Intraspecific variation in the molecular physiology of the cold water coral *Lophelia pertusa* in response to global climate change.

2. The impact of food availability on the response of *Lophelia pertusa* to global climate change.
3. Intraspecific physiological variation between distinct populations of *Lophelia pertusa* in response to natural differences in environmental conditions.

Further collaboration with Geoff Cook (US Fish and Wildlife Service) and Anne Cotton (University of Hull) will examine the effect of OA on rRNA expression in corals with identification of key proteins carried out in at UG. This collaboration will provide greater understanding of the effects of global climate change on the molecular physiology of cold-water corals.

Cold-water corals produce an aragonite (calcium carbonate) skeleton, the formation of which depends on the availability of carbonate ions. Under predicted scenarios for future climatic conditions, it is anticipated that many marine organisms will be exposed to undersaturated water, with regards to aragonite and a decrease in the availability of carbonate ions. This change in environmental conditions may hinder the calcification process and result in a change to the structure of the skeleton, with regards to the chemical composition and/ or the physical structure. Therefore structural analysis of coral skeletons is anticipated to become an important aspect of post-cruise research.

6.2.2 Methods

a. Coral collection by ROV: During dives, whenever sampling occurred, the time, method (manipulator claw or suction sampler) and designated receptacle were noted on logsheets. Upon return to the surface, individually labelled buckets filled with seawater were taken to the ROV to transfer live corals in water to the holding tanks. Samples were then placed in labelled baskets within the tanks so colonies could be traced back to the locations sampled. For Heriot-Watt Ocean Acidification Research, *Lophelia pertusa* was collected from Mingulay (Dive 004, JC073/026, HWU20120522/ROV/001), Logachev (Dive 19, JC073/095, HWU20120530/ROV/001) and *Madrepora oculata* from Logachev (Dive 19, JC073/095, HWU20120530/ROV/001). Fragments of each coral collected were sub-sampled and stored in either 4% buffered formalin for future histological analysis, or 96% ethanol for future genetic analysis.

b. Treatment tanks: Four 600 l incubation tanks (Figure 6.1) were fitted with external pumps (EHEIM Universal 1260) and chillers (Aqua-Medic Titan 500) to maintain water temperature at ambient seabed temperature, and the predicted temperature for the end of the century. Air bubbled into two of the tanks was from a Clarke Shhh2 air compressor. The air bubbled into the other two tanks was then combined with CO₂ using a gas mixer (see sub-section c below) to reflect the predicted CO₂ for the end of the century (750 ppm). The four treatments were thus:

380 ppm and 9°C (ambient)
750 ppm and 9°C

380 ppm and 12°C
750 ppm and 12°C

Once corals had been added to experimental tanks, the temperature in the two 12°C tanks were ramped 1°C every other day until the required temperature was reached. Water was circulated in each tank using submerged pumps (EHEIM Universal 1260). Every other day, a 50% of the seawater in each tank was changed. All seawater used in the tanks and during experiments was collected from 40-50 m depth using a submersible pump (KPZ GmbH, supplied by GEOMAR) attached to the CTD rosette frame in place of two of the Niskin bottles (Figure 6.2). The pH, temperature and salinity of each tank were recorded four times each day. The CO₂ levels being pumped into the treatment tanks were measured using a Licor 820 gas analyser.

In addition to the *p*CO₂ and temperature treatments some corals were kept in unfed conditions within the tanks. This was achieved by placing them in holding baskets lined with 15 µm mesh to exclude plankton and other small food particles present in the pumped seawater. The rest of the corals were in unlined baskets that allowed free movement of any plankton and other food particles. No other food was added to the tanks during the cruise.



Figure 6.1 Experimental tanks, chillers and pumps in the hangar of the *James Cook*.



Figure 6.2 Deep-sea pump attached to the CTD. Photo: J. Büscher

c. Gas mixing: Two high precision gas mixing pumps for corrosive gases (H. Wösthoff Messtechnik GmbH, Bochum – Germany) were used to produce climate change-relevant future scenario CO₂-air gas mixtures in the experimental incubation tanks. These gas mixing pumps were installed to enrich each of the two high CO₂ tanks to 750 µatm, the value projected to occur until the end of this century (Salomon *et al.*, 2007). The pumps were provided by GEOMAR (Research Department 2, Marine Biogeochemistry within Research Division Biological Oceanography led by Prof. Dr. Ulf Riebesell). These DIGAMIX piston pumps, type 5KA 36A/9 (Serial No. 26.075), are designed to produce two component gases discharging approximately 246.3 litres per hour.



Fig. 6.3 Gas-mixing pumps with air compressor to the right. Photo: J. Büscher

d. Coral ecophysiology: Physiological measurements of *L. pertusa* from the Mingulay Reef Complex were taken following 24 h in holding tanks. Specifically, we measured respiration rates, calcification rates using ⁴⁵Ca and the alkalinity anomaly technique (AAT), mucus excretion and feeding. Twenty-six fragments were added to each treatment tank in labelled autoclave baskets on the 24th May. After nine days, we measured respiration and calcification using the alkalinity anomaly technique in eight fragments from each treatment. After 21 days, respiration, calcification, and mucus excretion were measured in the remaining fragments.

Lophelia pertusa from the Logachev mounds were also added to the treatment tanks on the 31st May, following measurements of respiration and calcification (AAT). After nine days in treatment tanks, measurements of respiration and calcification were repeated, to allow for comparison with *L. pertusa* collected from the shallower site (Mingulay).

Respiration and calcification rates of freshly collected *Madrepora oculata* were determined on the 30th May. Eight fragments of *M. oculata* were then added to each treatment tank. Following 12 days incubation, respiration and calcification were again determined.

Additional measurements of respiration and calcification (AAT) were conducted on *M. oculata* and *L. pertusa* collected from *Pisces* 9 on the 6th June. ⁴⁵Ca calcification was also determined in *M. oculata*.

e. Respiration: Rates of oxygen consumption were assessed in coral fragments placed within 220 ml incubation chambers each fitted with a magnetic stirrer and oxygen optode connected to a temperature-compensated oxygen analyser (Oxy-4 Mini with Temp-4, Presens & Loligo systems). Chambers were filled with tank seawater and corals allowed to acclimate for 2 hours. Corals were not fed for 48 h before any respiration measurements. Oxygen consumption was recorded for a 40 minute period for each fragment, during which oxygen saturation did not fall below 80%. Following incubations, fragments were removed and preserved at -20°C for subsequent weight determination. Upon return to Heriot-Watt University, dry weight and ash free dry weight (450°C for 4 hours) were determined, and rates of oxygen consumption converted to $\mu\text{g C g tissue}^{-1} \text{ h}^{-1}$ using a respiratory quotient of 0.8 (equal to CO_2 eliminated/ O_2 consumed, Hatcher 1989). As the precise *in situ* diet of the corals is unknown, the RQ represents the mean value reported for several benthic marine invertebrates (Hatcher 1989).

f. Alkalinity anomaly technique: Calcification rates of *L. pertusa* and *Madrepora oculata* were determined using the alkalinity anomaly technique (Smith & Key 1975, Ohde and Hossain 2004) in which coral fragments were incubated in stirred 220 ml chambers for a 4 h period. Samples of incubation water were taken at the beginning and end of the experimental period, and total alkalinity determined using an automatic titrator (Metrohm 702 SM Titrino). Calcification ($\mu\text{mol CaCO}_3 \text{ g h}^{-1}$) was estimated using the equation:

$$\text{Calcification} = 0.5(\Delta\text{TA}) \bullet V / \Delta T / \text{TDW}$$

where ΔTA is the change of total alkalinity (mol/kg), W is the weight of experimental seawater (kg) and ΔT is the experimental period (h).

g. Calcification: Calcification rate in *L. pertusa* were also measured by incorporation of ⁴⁵Ca, whereby fragments of live corals were placed in tubes with 30 ml filtered seawater (FSW) maintained at ambient tank temperature (9°C or 12°C). After 1 h acclimation, 120 μl was added to each tube to a final activity of 3 kBq ml^{-1} (Al-horani *et al.* 2005), including a control tubes with 30 ml FSW. Ship movement and a pump attached to the chiller maintained gentle movement of the tubes. Immediately following addition and mixing of 120 μl , 100 μl of incubation water was removed and added to 4 ml of Optisafe scintillation cocktail to assess total activity. Following 6 h incubation, another 100 μl was taken to assess total activity in incubation water, and the coral fragments were rinsed twice to remove unbound tracer. Corals were then preserved at -20°C for subsequent weight determination (see Section e. *Respiration*).

h. Mucus excretion: To quantify release rates of DOC and POC, coral fragments were incubated as per Wild *et al.* (2008). Briefly, eight fragments were separately transferred to 1 l beakers containing 800 ml of filtered seawater, with two chambers remaining empty to act as controls. All polyps expanded during the incubations indicating the corals had recovered from collection

and fragmentation disturbance. Ship movement gave sufficient water motion. Following 4 hour incubation, coral fragments were removed and preserved at -20°C for subsequent weighing. The incubation water was homogenised by gentle stirring and subsamples for analysis were taken in two ways. Firstly, 20 ml was filtered (0.2 µm Millex Nylon membrane filters) into pre-combusted 30 ml brown glass vials (before this another 2 ml aliquot of each incubation volume was pre-filtered and discarded in order to clean the filter). Samples were immediately frozen at -20°C and kept frozen until DOC analysis. Secondly, 200 ml incubation water was filtered onto pre-combusted GF/F filters (Whatman, 25 mm in diameter; combusted for 4 to 6 h at 500°C). The filters were preserved at -20°C. Following return to Heriot-Watt University the filters were freeze-dried and transferred to Kostas Kirakoulakis at Liverpool John Moores University for analysis of DOC and POC.

i. Feeding: Following acclimation to aquaria conditions, feeding experiments were conducted on both *Lophelia pertusa* from the Mingulay Reef Complex and Logachev mounds, and *Madrepora oculata* from the Logachev Mounds in individual 220 ml cylindrical PVC chambers fitted with stirrers to create a circular flow. *Artemia* nauplii were cultured in filtered seawater, and a stock solution of freshly hatched nauplii was prepared. Quantified sub-samples of *Artemia* nauplii were filtered through pre-combusted pre-weighed GF/F filters, and the carbon content determined *as per* POC of mucus samples. Live algae (*Skeletonema costatum* (now *S. marinoi*), CCAP Strain 1077/5) were also cultured and brought to sea so that aliquots could be used in feeding experiments. Five live coral fragments were placed in the chambers filled with filtered seawater. An additional two chambers acted as controls, one remained empty and one contained a dead bleached coral skeleton. Following 30 minutes acclimation, 1 ml of *Artemia*, algae or mixed prey stock solution was added to each chamber. Every 30 minutes for a 2-hour period, 1 ml of chamber water was removed and preserved in 4% formalin for subsequent counts. Skeletons were preserved at -20°C for weight determination.

j. Fitness and respiration (GEOMAR): Fitness of the corals will be determined after the cruise using fluorometric RNA/DNA ratio measurements. Polyps of *Lophelia pertusa* and *Madrepora oculata* were either fixed in RNAlater® and stored in the freezer at -20°C or directly preserved by being frozen in their surrounding seawater. In order to reduce stress-induced changes in RNA/DNA ratios after collection, coral polyps were preserved immediately after a dive. In addition, some polyps were incubated for a week in the experimental tanks, which were then also preserved in RNAlater® and seawater.

Respiration rates of *Lophelia pertusa* fragments from the Mingulay Reef Complex were measured using an optode based oxygen analyser (Oxy-10 mini, PreSens GmbH) before and after incubation in the four different experimental treatment tanks. Oxygen consumption was assessed in five 800 ml stirred respiration chambers equipped with an oxygen sensor spot (PreSens oxy-SP-PSt3-NAU-D7-YOP). A water bath containing the chambers was re-filled with pumped seawater from 40-50 m depth before each measurement. Four replicates of each of the four treatments were measured simultaneously. One chamber remained empty during each measurement as a blank. After the initial measurement of each four fragments, replicates were

incubated for 10 days within the specific treatment conditions. Fragments were slowly acclimatised to either higher CO₂ or higher temperature conditions, or both synergistically, before treatment incubation. Within the measurement tank coral fragments were allowed to acclimatise for twelve hours before the 24 hours oxygen measurement period with closed lids began. The experimental measurement tank was equipped with a stream pump (Hydor Koralia Nano 900) for water circulation and an adjustable aquarium heater (MP No. H600162) as well as a chiller (TECO® TR10) to maintain the desired water temperature. Before pre-acclimatisation of the replicates in the second measurement period (repeated measurement after 10 days incubation), the measurement tank was adjusted to the specific treatment conditions. Following incubations, fragments were frozen at -20°C for subsequent weight determinations at GEOMAR.

k. Proteomics and skeletal analysis: Fragments of *Lophelia pertusa* were collected from two sites (Mingulay and Logachev). Five colonies of *L. pertusa* were identified from each site (Mingulay and Logachev) and four fragments from each colony were allocated to one of the four treatments. In addition, each of the four treatments had a replicate that was fed (corals had access to food naturally available in the seawater) and unfed (corals in baskets lined with 15 µm mesh net to exclude plankton and food particles). Before the start of the experiment one polyp from each fragment was removed and immediately frozen in liquid nitrogen to obtain T₀ information. Temperature, salinity and pH were monitored in collaboration with HWU (see above methods). In addition, water samples were taken from the experimental tanks throughout the duration of the experiment for analysis of dissolved inorganic carbon (DIC) and total alkalinity (TA). Coral fragments for proteomic analysis were 'snap frozen' in liquid nitrogen and then stored in -80°C freezer to be transported back to the University of Glasgow. Fragments of *L. pertusa* were placed in each of the four treatments. Fragments of *L. pertusa* from each of the four treatments were removed after 21 days and air-dried before skeletal analysis (e.g. SEM) at the University of Glasgow.

6.2.3 Initial Results

a. Coral ecophysiology (HWU): Rates of oxygen consumption were determined in *Lophelia pertusa* from Mingulay and the Logachev mounds, and in *Madrepora oculata* from the Logachev mounds. Table 1 summarises fragments in which oxygen depletion rates were measured. No results are presented for any physiological studies since all data need to be correctly normalised to respiring tissue biomass, determinations that will be made after the cruise.

Table 6.1 Respiration measurements conducted during JC073. Code refers to the experiment the fragments were from: LT: long-term experiment, B: Baseline

Date	No. of samples	Coral	Site	Code	Treatment
25/05/2012	8	<i>Lophelia</i>	Mingulay	LT	Control
28/05/2012	8	<i>Madrepora</i>	Logachev 1	B	-
30/05/2012	8	<i>Madrepora</i>	Logachev 1	LT	Control
30/05/2012	2	<i>Madrepora</i>	Logachev 1	LT	Control
31/05/2012	8	<i>Lophelia</i>	Logachev 1	LT	Control
02/06/2012	8	<i>Lophelia</i>	Mingulay	LT	Control
02/06/2012	8	<i>Lophelia</i>	Mingulay	LT	750ppm, 9°C
02/06/2012	8	<i>Lophelia</i>	Mingulay	LT	380ppm, 12°C
02/06/2012	8	<i>Lophelia</i>	Mingulay	LT	750ppm, 12°C
06/06/2012	8	<i>Madrepora</i>	Logachev 1	B	-
06/06/2012	8	<i>Lophelia</i>	Logachev 1	B	-
09/06/2012	8	<i>Lophelia</i>	Logachev 1	LT	Control
09/06/2012	8	<i>Lophelia</i>	Logachev 1	LT	750ppm, 9°C
09/06/2012	8	<i>Lophelia</i>	Logachev 1	LT	380ppm, 12°C
09/06/2012	8	<i>Lophelia</i>	Logachev 1	LT	750ppm, 12°C
11/06/2012	8	<i>Madrepora</i>	Logachev 1	LT	Control
11/06/2012	8	<i>Madrepora</i>	Logachev 1	LT	750ppm, 9°C
11/06/2012	8	<i>Madrepora</i>	Logachev 1	LT	380ppm, 12°C
11/06/2012	8	<i>Madrepora</i>	Logachev 1	LT	750ppm, 12°C
12/06/2012	8	<i>Lophelia</i>	Mingulay	LT	Control
12/06/2012	8	<i>Lophelia</i>	Mingulay	LT	750ppm, 9°C
12/06/2012	8	<i>Lophelia</i>	Mingulay	LT	380ppm, 12°C
12/06/2012	8	<i>Lophelia</i>	Mingulay	LT	750ppm, 12°C
13/06/2012	8	<i>Lophelia</i>	Mingulay	LT	750ppm, 9°C, unfed
13/06/2012	8	<i>Lophelia</i>	Mingulay	LT	750ppm, 12°C, unfed

b. Alkalinity Anomaly Technique (HWU): Rates of calcification, measured as the change in total alkalinity, were determined in *Lophelia pertusa* from Mingulay and the Logachev mounds, and in *Madrepora oculata* from the Logachev mounds. Table 6.2 summarises fragments in which the change in total alkalinity was recorded.

Table 6.2 Calcification measurements, measured as the change in total alkalinity, conducted during JC073. Code refers to the experiment the fragments were from: LT: long-term experiment, B: Baseline

Date	No. of samples	Coral	Site	Duratio n	Code	Treatment
25/05/2012	8	<i>Lophelia</i>	Mingulay	4.2	LT	Control
28/05/2012	8	<i>Madrepora</i>	Logachev 1	4	B	-
30/05/2012	8	<i>Madrepora</i>	Logachev 1	4	LT	Control
30/05/2012	8	<i>Madrepora</i>	Logachev 1	4.25	LT	Control
31/05/2012	8	<i>Lophelia</i>	Logachev 1	4.75	LT	Control
02/06/2012	8	<i>Lophelia</i>	Mingulay	4.75	LT	Control
02/06/2012	8	<i>Lophelia</i>	Mingulay	4	LT	750ppm, 9°C
02/06/2012	8	<i>Lophelia</i>	Mingulay	4	LT	380ppm, 12°C
02/06/2012	8	<i>Lophelia</i>	Mingulay	4	LT	750ppm, 12°C
06/06/2012	8	<i>Madrepora</i>	Logachev 1	4	B	-
06/06/2012	8	<i>Lophelia</i>	Logachev 1	4	B	-
09/06/2012	8	<i>Lophelia</i>	Logachev 1	4	LT	Control
09/06/2012	8	<i>Lophelia</i>	Logachev 1	4.25	LT	750ppm, 9°C
09/06/2012	8	<i>Lophelia</i>	Logachev 1	4.25	LT	380ppm, 12°C
09/06/2012	8	<i>Lophelia</i>	Logachev 1	3.75	LT	750ppm, 12°C
11/06/2012	8	<i>Madrepora</i>	Logachev 1	4	LT	Control
11/06/2012	8	<i>Madrepora</i>	Logachev 1	4	LT	750ppm, 9°C
11/06/2012	8	<i>Madrepora</i>	Logachev 1	4	LT	380ppm, 12°C
11/06/2012	8	<i>Madrepora</i>	Logachev 1	4	LT	750ppm, 12°C
12/06/2012	8	<i>Lophelia</i>	Mingulay	4	LT	Control
12/06/2012	8	<i>Lophelia</i>	Mingulay	4	LT	750ppm, 9°C
12/06/2012	8	<i>Lophelia</i>	Mingulay	4	LT	380ppm, 12°C
12/06/2012	8	<i>Lophelia</i>	Mingulay	4	LT	750ppm, 12°C
13/06/2012	8	<i>Lophelia</i>	Mingulay	4	LT	750ppm, 9°C, unfed
13/06/2012	8	<i>Lophelia</i>	Mingulay	4	LT	750ppm, 12°C, unfed

c. Calcification (HWU): Calcification was also measured using the isotope ^{45}Ca , in *Lophelia pertusa* from Mingulay at the beginning and end of the experimental incubations, and in *Madrepora oculata* from the Logachev mounds. Table 6.3 summarises fragments in which calcification was determined.

Table 6.3 Calcification measurements, measured by ^{45}Ca , conducted during JC073.

Date	No. of samples	Coral	Site	Experiment
25/5/12	8	<i>Lophelia</i>	Mingulay	Long-term
6/6/12	8	<i>Madrepora</i>	Logachev	Baseline
12/6/12	8	<i>Lophelia</i>	Mingulay	Long-term, control
12/6/12	8	<i>Lophelia</i>	Mingulay	Long-term, 9°C, 750ppm
13/6/12	8	<i>Lophelia</i>	Mingulay	Long-term, 12°C, 380ppm
13/6/12	8	<i>Lophelia</i>	Mingulay	Long-term, 12°C, 750ppm

d. Mucus excretion (HWU): The amount of carbon excreted as mucus was determined in *Lophelia pertusa* from Mingulay at the beginning and end of the experimental incubations, and in *Madrepora oculata* from the Logachev mounds. Table 6.4 summarises fragments in which mucus excretion rates were determined.

Table 6.4 Mucus excretion incubations conducted during JC073.

Date	No. of samples	Coral	Site	Experiment
24/5/12	6	<i>Lophelia</i>	Mingulay	Long term
29/5/12	6	<i>Madrepora</i>	Logachev 1	Baseline
12/6/12	8	<i>Lophelia</i>	Mingulay	Long-term, 9°C, 380ppm
12/6/12	8	<i>Lophelia</i>	Mingulay	Long-term, 9°C, 380ppm
12/6/12	8	<i>Lophelia</i>	Mingulay	Long-term, 12°C, 380ppm
12/6/12	8	<i>Lophelia</i>	Mingulay	Long-term, 12°C, 750ppm

e. Fitness and respiration (GEOMAR): Samples for fitness analysis were taken from *Lophelia pertusa* from Mingulay and the Logachev mounds, and from *Madrepora oculata* from the Logachev mounds. Table 6.5 summarises the sampling regime of preserved coral polyps.

Table 6.5 Date and location details of collected and preserved *Lophelia pertusa* and *Madrepora oculata* samples/polyps for RNA/DNA analysis.

Date	Station	Dive #	Location	Treatment	Coral	Replicates	Preserved
22/05/12	026	4	Mingulay	ambient	<i>Lophelia</i>	4	RNAlater
22/05/12	026	4	Mingulay	ambient	<i>Lophelia</i>	4	seawater
22/05/12	026	4	Mingulay	ambient	<i>Lophelia</i>	2	RNAlater
22/05/12	026	4	Mingulay	ambient	<i>Lophelia</i>	2	seawater
22/05/12	027	5	Mingulay	ambient	<i>Lophelia</i>	2	RNAlater
22/05/12	027	5	Mingulay	ambient	<i>Lophelia</i>	2	seawater
22/05/12	027	5	Mingulay	ambient	<i>Lophelia</i>	4	RNAlater
22/05/12	027	5	Mingulay	ambient	<i>Lophelia</i>	4	seawater
05/06/12	126	25	Logachev	ambient	<i>Lophelia</i>	5	RNAlater
05/06/12	126	25	Logachev	ambient	<i>Lophelia</i>	7	seawater
05/06/12	126	25	Logachev	ambient	<i>Madrepora</i>	1	RNAlater
05/06/12	126	25	Logachev	ambient	<i>Madrepora</i>	1	seawater
05/06/12	127	26	Logachev	ambient	<i>Lophelia</i>	2	RNAlater
05/06/12	127	26	Logachev	ambient	<i>Lophelia</i>	3	seawater
05/06/12	127	26	Logachev	ambient	<i>Madrepora</i>	4	RNAlater
05/06/12	127	26	Logachev	ambient	<i>Madrepora</i>	11	seawater
13/06/12	026/027	4/5	Mingulay	380µatm,9°C	<i>Lophelia</i>	1	RNAlater
13/06/12	026/027	4/5	Mingulay	380µatm,9°C	<i>Lophelia</i>	2	seawater
13/06/12	126/127	25/26	Logachev	380µatm,9°C	<i>Lophelia</i>	1	RNAlater
13/06/12	126/127	25/26	Logachev	380µatm,9°C	<i>Lophelia</i>	5	seawater
13/06/12	026/027	4/5	Mingulay	380µatm,12°C	<i>Lophelia</i>	1	RNAlater
13/06/12	026/027	4/5	Mingulay	380µatm,12°C	<i>Lophelia</i>	4	seawater
13/06/12	126/127	25/26	Logachev	380µatm,12°C	<i>Lophelia</i>	1	RNAlater
13/06/12	126/127	25/26	Logachev	380µatm,12°C	<i>Lophelia</i>	4	seawater
13/06/12	026/027	4/5	Mingulay	750µatm,9°C	<i>Lophelia</i>	1	RNAlater
13/06/12	026/027	4/5	Mingulay	750µatm,9°C	<i>Lophelia</i>	3	seawater
13/06/12	126/127	25/26	Logachev	750µatm,9°C	<i>Lophelia</i>	1	RNAlater
13/06/12	126/127	25/26	Logachev	750µatm,9°C	<i>Lophelia</i>	3	seawater
13/06/12	026/027	4/5	Mingulay	750µatm,12°C	<i>Lophelia</i>	1	RNAlater
13/06/12	026/027	4/5	Mingulay	750µatm,12°C	<i>Lophelia</i>	4	seawater
13/06/12	126/127	25/26	Logachev	750µatm,12°C	<i>Lophelia</i>	1	RNAlater
13/06/12	126/127	25/26	Logachev	750µatm,12°C	<i>Lophelia</i>	3	

Oxygen consumption rates were measured in *Lophelia pertusa* samples from Mingulay and the Logachev mounds, and in *Madrepora oculata* from the Logachev mounds. Table 6.6 summarises fragments in which oxygen depletion rates were measured.

Table 6.6 Location and measurement schedule of corals used for oxygen consumption determination

Station	Dive #	Location	Species	Treatment	Replicate	Date 1 st measurement	Date 2 nd measurement
26/27	4/5	Mingulay	<i>Lophelia</i>	380µatm, 9°C	R1	25/05/2012	06/06/2012
26/27	4/5	Mingulay	<i>Lophelia</i>	380µatm, 9°C	R2	25/05/2012	06/06/2012
26/27	4/5	Mingulay	<i>Lophelia</i>	380µatm, 9°C	R3	25/05/2012	06/06/2012
26/27	4/5	Mingulay	<i>Lophelia</i>	380µatm, 9°C	R4	25/05/2012	06/06/2012
26/27	4/5	Mingulay	<i>Lophelia</i>	380µatm, 12°C	R1	27/05/2012	08/06/2012
26/27	4/5	Mingulay	<i>Lophelia</i>	380µatm, 12°C	R2	27/05/2012	08/06/2012
26/27	4/5	Mingulay	<i>Lophelia</i>	380µatm, 12°C	R3	27/05/2012	08/06/2012
26/27	4/5	Mingulay	<i>Lophelia</i>	380µatm, 12°C	R4	27/05/2012	08/06/2012
26/27	4/5	Mingulay	<i>Lophelia</i>	750µatm, 9°C	R1	01/06/2012	12/06/2012
26/27	4/5	Mingulay	<i>Lophelia</i>	750µatm, 9°C	R2	01/06/2012	12/06/2012
26/27	4/5	Mingulay	<i>Lophelia</i>	750µatm, 9°C	R3	01/06/2012	12/06/2012
26/27	4/5	Mingulay	<i>Lophelia</i>	750µatm, 9°C	R4	01/06/2012	12/06/2012
26/27	4/5	Mingulay	<i>Lophelia</i>	750µatm, 12°C	R1	30/05/2012	10/06/2012
26/27	4/5	Mingulay	<i>Lophelia</i>	750µatm, 12°C	R2	30/05/2012	10/06/2012
26/27	4/5	Mingulay	<i>Lophelia</i>	750µatm, 12°C	R3	30/05/2012	10/06/2012
26/27	4/5	Mingulay	<i>Lophelia</i>	750µatm, 12°C	R4	30/05/2012	10/06/2012
127	26	Logachev	<i>Madrepora</i>	ambient	R1	13/06/2012	-
127	26	Logachev	<i>Madrepora</i>	ambient	R2	13/06/2012	-
127	26	Logachev	<i>Madrepora</i>	ambient	R3	13/06/2012	-
127	26	Logachev	<i>Madrepora</i>	ambient	R4	13/06/2012	-

f. Proteomics and skeletal analysis: In addition to the sampling for proteomics and skeletal analysis, the University of Glasgow also sampled seawater for total alkalinity and DIC analysis. Water samples were taken from all the coral experimental tanks at time 0 and after 7, 10, 14 and 22 days.

Treatment	Collection location (no. of fragments collected)	Sampling points (days):				
		T0	7	10	14	22
FED: 9°C & 12°C(380, 750)		Mingulay (80) Logachev (40)	Mingulay	Mingulay Logachev	Mingulay Logachev	Mingulay
NON-FED: 9°C, 380 ppm		Mingulay (40)	-	Mingulay	-	DEAD*
9°C, 750 ppm			-	DEAD*	-	DEAD*
12°C (750, 380 ppm)			-	Mingulay	-	Mingulay
	Number of polyps/ fragments sampled	One polyp from each fragment	5 fragments from each treatment	5 fragments from each treatment	5 fragments from each treatment	5 fragments from each treatment

Fig. 6.4 Schematic illustrating the number of *Lophelia pertusa* coral fragments transferred to the experimental tanks and the subsequent sampling for proteomics. *indicates treatments that were not sampled due to coral mortality.

Table 6.7 Summary of all the *Lophelia pertusa* collected from three different locations in the North Atlantic to be used for comparison of protein expression between sites.

Collection site	Depth (m)	Sample details
Mingulay	135	TØ samples from OA/temp experiment
Logachev	844	TØ samples from OA/temp experiment
	640	5 fragments, from 5 colonies
	706	5 fragments, from 5 colonies
<i>Pisces 9</i>	258	5 fragments, from 5 colonies
	265	5 fragments, from 5 colonies

Table 6.8 Summary of *Lophelia pertusa* collected for skeletal analysis. *indicates mortality in treatment with samples were collected and dried on day 17 of the experiment.

Treatment	Number of Fragments
FED: 9°C & 12°C (380, 750 ppm)	5 per treatment
UNFED: 9°C (380*, 750 ppm) & 12°C (750)	5 per treatment

6.2.4 Further analysis planned

a. Coral ecophysiology (HWU): To predict how cold-water corals will respond to ocean warming and acidification conditions predicted for the end of the century, we will examine changes in respiration, calcification and excretion of *Lophelia pertusa* from the Mingulay Reef Complex between the OA and warming treatments over the 21-day period of the experiment at sea. These changes will be compared to changes in *L. pertusa* from the Logachev mounds over a 9-day period, and *Madrepora oculata* over a 14-day period.

We aim to construct a carbon budget for *Lophelia pertusa* from Mingulay, and *Madrepora oculata* from the Logachev mounds. Additionally, we will compare respiration and calcification rates of both species between the sites from which we collected on this cruise, and previous work onboard the FS *Poseidon* in 2011.

b. Fitness and respiration (GEOMAR): Analysis of preserved coral samples taken on this cruise will take place after the cruise using fluorometric determination of the RNA and DNA content according to Clemmesen (1993) and Belchier *et al.* (2004). Adaptations of these methods for cold-water coral material have been developed by Gutperlet (2008). Tissues of *Lophelia pertusa* and *Madrepora oculata* will be processed with an RNA/DNA analyser (Fluoroskan Ascent®, Thermo) in the laboratories at GEOMAR in Kiel. As specimens for fitness measurements were collected at different sites and fixed in the stabilising solution immediately after they came up with the ROV, the general *in situ* fitness status of *Lophelia pertusa* in terms of RNA/DNA ratios from different locations (shallow Mingulay areas (150 – 200 m) vs. deeper reef systems, e.g.

Logachev Mound (600-800 m) in the Rockall Banks) with distinct flow velocities, chemistry and food availability, will be compared. Moreover, *in situ* baseline measurements will be compared with polyps that were incubated for 10 days in the different future climate change tank conditions.

Frozen fragments that were used for respiration measurements will be normalised following the protocols described by Dodds (2007). Oxygen consumption being measured immediately after the corals were collected on board the vessel will be compared with the rates after they have been for 10 days in the experimental conditions.

c. Proteomics and skeletal analysis (Glasgow): All proteomic analysis will be carried out at the University of Glasgow including identification of proteins involved in key biological processes and quantification of protein concentration and expression. Seawater samples from the experimental tanks will also be transported to the University of Glasgow where analysis will take place. Additional carbonate parameters ($p\text{CO}_2$, calcite and aragonite saturation, $[\text{HCO}_3^-]$ and $[\text{CO}_3^{2-}]$) will be calculated from total DIC and TA values using the software program CO2SYS (Pierrot *et al.* 2006) with dissociation constants from Mehrbach *et al.* (1973) refit by Dickson & Millero (1987) and $[\text{KSO}_4]$ using Dickson (1990).

6.3 Trophic and reproductive ecology of *Lophelia pertusa* (Covadonga Orejas)

Lophelia pertusa is the most abundant reef framework-forming cold-water coral (CWC). This CWC is known to form important structural habitats in shelf and seamount habitats around the world. However, there are still key aspects of its ecology and functionality in deep-sea benthic communities that remain unclear. There are particular gaps in our understanding of the trophic ecology of this species, one of the most important aspects of the functional role any species under the wider ecosystem approach. Thus the main aim of this research was to gain insight into the trophic ecology of *L. pertusa*. This information will enable further understanding in relation to its ecological role and functioning in deep-water ecosystems.

6.3.1 Aims and objectives

The work conducted was focused on two aspects of the ecology of *Lophelia pertusa*:

(1) The influence of trophic ecology on L. pertusa reproduction: single colony response, inter-colony and inter-site variability.

Azooxanthellate coral species such as *L. pertusa* obtain energy by filter feeding particulate organic matter (POM), as well as by capturing phyto- and zooplankton (Roberts *et al.* 2009b). The energy derived is used by the coral to satisfy its energetic demand, with the energy surplus being invested into growth and reproduction, thus resulting in a direct interdependence between trophic ecology, growth, and reproduction. The main aim of this study was to establish relationships (correlations) between: (1) the energetic state of *Lophelia pertusa* colonies, (2) their main food sources, (3) their reproductive output, and (4) the quality of the produced gametes. Moreover, complementary genetic analysis would also be performed to explore potential differences in the genotypes observed to correlate with the energetic state and/or the reproductive output. To our knowledge, this study is one of the first ones focusing on the specific characteristics of each single coral colony, their inter-colony variability with emphasis on the ecological responses to food quality and availability.

(2) The quantification of Particulate Organic Matter (POM) uptake by L. pertusa in experimental chambers at different current speeds.

In the last 5 years, advances in trophic ecology research for understanding food supply to cold-water corals (CWC) have been achieved (e.g. Davies *et al.* 2009, Dodds *et al.* 2009, van Ovelen *et al.* 2009, Tsounis *et al.* 2010, Purser *et al.* 2010). The currently available evidence, together with former experiments developed in Polar and deep waters with different suspension feeders (e.g. ascidians: Tatián *et al.* 2002, cnidarians: Orejas *et al.* 2001, 2003, sponges: Pile & Young 2006) contribute to our knowledge on the trophic ecology of suspension feeder organisms from deep waters habitats.

Previous collaborative research supported via two EU ASSEMBLE projects (www.assemblemarine.org) was to expand our current knowledge on the feeding ecology of *L. pertusa*. These feeding experiments were set-up with zooplankton and algal sources at three current speeds (e.g. 2, 5 and 10 cm/s). This EU research provided the basis to understand initial feeding response of *Lophelia pertusa*, which characterised as a suspension feeding species. Therefore, this coral may have the capacity to capture particulate organic matter (POM), which it is believed to cover (at least partially) their energetic demand, although this work remains in its infancy. However, studies such as those conducted by Coma *et al.* (1995) show some indication that this fraction is captured by some suspension feeders. Therefore, a major objective of this work was to quantify the uptake of POM by *Lophelia pertusa* under experimental conditions (in chambers), to enable a better understanding of the trophic ecology of this species.

6.3.2 Methods

(1) *The influence of trophic ecology on L. pertusa reproduction: single colony response, inter-colony and inter-site variability.*

Samples from different *Lophelia pertusa* colonies (three samples from each colony, Figure 6.5) were collected at different study sites (see Table 6.9). A total of 24 colonies were preserved: 9 colonies from Mingulay reef, 8 colonies from Logachev mounds (Rockall Bank) and 7 colonies from Pisces 9 location.

The samples collected for the assessment of the energetic state of the colonies and their main sources of food were stored at -20°C, whilst samples to be analyzed for to determine reproductive output and the quality of the produced gametes (using histochemical techniques) were preserved in 10% formalin (to study its reproduction) and in Davidson's solution (quality of produced gametes) for 48 hours. These samples were transferred to 70% ethanol for preservation. Samples for genetic analyses were preserved in 100% ethanol (one sample from each colony).

The energetic state of each colony will be quantified through the total biochemical analyses of the coral tissue composition in proteins, carbohydrates and lipids (Ben-David-Zaslow & Benayahu 1999, Rossi *et al.* 2006, Gori *et al.* 2007). The main food source for each colony will be assessed by analyzing fatty acids and stable isotopes (Kiriakoulakis *et al.* 2005, Carlier *et al.* 2009, Dodds *et al.* 2009).

The reproductive output of each colony will be assessed in terms of number and volume of the gametes by histological analyses (Burgess and Babcock 2005, Waller and Tyler 2005). The quality of the gametes, in terms of amounts of lipids stored in the eggs, will be quantified by histochemical, stereological and calorimetric methods (Cáceres-Puig *et al.* 2009, Angel-Dapa *et al.* 2010).

A summary of the sampled stations and number of colonies can be seen in Table 6.9. The corresponding coordinates and depth of each sampling station with further details on each activity can be also found in the complete station list (see Appendix 1).

Table 6.9 Summary of samples collected during the cruise. Abbreviations as follows: MR= Mingulay Reef, LM= Logachev Mounds, P9= *Pisces* 9

Date	Area	Activity no.	Gear	Gear No	Samples	Histochemistry	Biochem. & stable isotopes	Reproduction	Genetics	Skeletal density
19/05	MR1	6	ROV	2	colony 1	X	X	X	X	
20/05	MR1	7	ROV	3	colony 2	X	X	X	X	
22/05	MR1	26	ROV	4	colony 3	X	X	X	X	
22/05	MR1	27	ROV	5	colony 4	X	X	X	X	
22/05	MR1	27	ROV	5	colony 5	X	X	X	X	
22/05	MR1	27	ROV	5	colony 6	X	X	X		
22/05	MR1	27	ROV	5	colony 7	X	X	X	X	
22/05	MR1	27	ROV	5	colony 8	X	X	X	X	X
13/06	MR 1	180	ROV	41	colony 24	X	X	X	X	
27/05	LM1	60	ROV	12	colony 9	X	X	X	X	X
29/05	LM1	91	Box corer	23	colony 10	X	X	X	X	
29/05	LM1	92	Box corer	24	colony 11	X	X	X	X	
30/05	LM2	95	ROV	19	colony 12	X	X	X	X	
30/05	LM2	95	ROV	19	colony 13	X	X			
30/05	LM2	95	ROV	19	colony 14	X	X	X	X	X
04/06	LM3	127	ROV	26	colony 15	X	X			
06/06	LM1	141	ROV	28	colony 16	X	X			
07/06	P9	145	ROV	30	colony 17	X	X	X	X	
07/06	P9	146	ROV	31	colony 18	X	X	X	X	
07/06	P9	146	ROV	31	colony 19	X	X	X	X	
07/06	P9	146	ROV	31	colony 20	X	X	X	X	
08/06	P9	147	ROV	32	colony 21	X	X	X	X	X
08/06	P9	147	ROV	32	colony 22	X	X	X	X	X
08/06	P9	147	ROV	32	colony 23	X	X	X	X	X

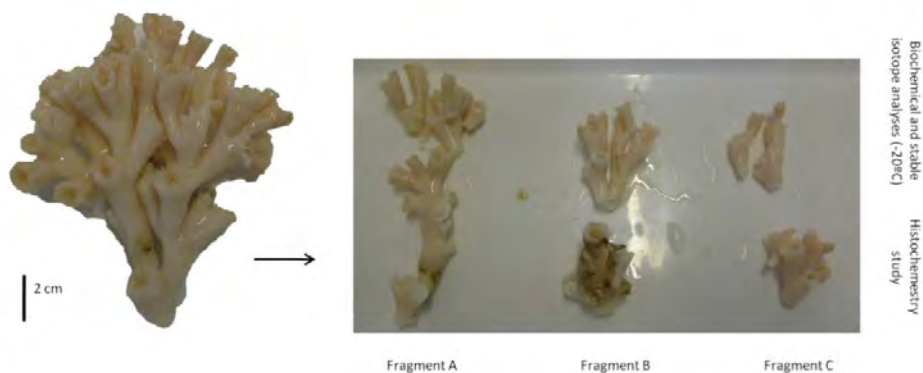

Figure 6.5 Examples of sampling processing for biochemical, stable isotope analyses and for histochemistry work.

*(2) The quantification of Particulate Organic Matter (POM) uptake by *L. pertusa* in experimental chambers at different current speeds.*

Feeding experiments were carried out in the CT room on board RRS *James Cook*. The experimental chambers (Figure 6.6) and all material employed in the experiments were carefully cleaned with 1% HCl to remove all organic matter and rinsed with MilliQ water. The chambers were then filled with chilled (8-9°C) filtered sea water (0.2 µm). Each trial consisted of three experimental chambers (each containing 2 coral nubbins, with approximately 9 to 10 polyps total) and one control chamber (containing a dead *Lophelia* nubbin). Chambers were also supplied with a stirrer to control flow speed inside the chamber. Every trial was conducted at a fixed current speed of 2, 5 or 10 cm/s. The overall duration of each experiment was 4 hours.

The experiment started when polyps expanded. When the polyps were open (a minimum of at least 50% of polyps in each chamber), a known concentration of food (5 mg of algae extract, which represented a total of 200 µg Particulate Organic Matter, POM), was added with a Pasteur pipette to each chamber. A water sample (2 litres) was taken immediately after adding the food to each chamber (Ti), and at the end (Tf) of the experiment (after four hours). The activity of the coral polyps (degree of expansion) was monitored every hour. The 2 litre water sample from each chamber was filtered through GFF/F filters (Figure 6.7) and preserved in criovials at -20°C. The content of POC extracted in the filters will be analysed later in the laboratory with a CHN analyzer.

A total of 8 experiments were conducted on board with the following speeds, these were: i) three at 2cm/s and ii) three at 5 cm/s and iii) two at 10 cm/s. This work will complement previous experimental research conducted to understand the feeding ecology of *L. pertusa* conducted during the two previous EU ASSEMBLE projects (in cooperation with SAMS and the HWU) with zooplankton and algae as prey.

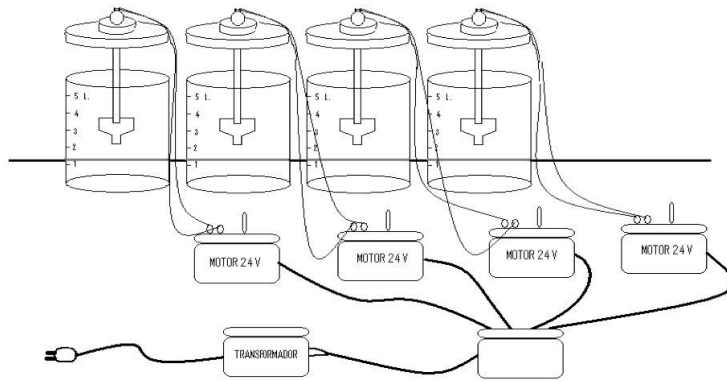

Figure 6.6 Top: Schematic illustration of the experimental chambers. Bottom: (Left) experimental set up on board RRS *James Cook* and (right), image showing the expanded polyps of a *L. pertusa* nubbin in the experimental chambers during one of the experiments.



Figure 6.7 Filtration set-up used on board RRS *James Cook*. The bottles contain the sampled water used in each experimental and control chambers.

6.3.3 Results and initial conclusions

The work conducted whilst on board was focused upon data collection. However, although no results will be available until the samples are processed the outcome of the work is summarised below.

(1) The influence of trophic ecology on L. pertusa reproduction: single colony response, inter-colony and inter-site variability

The opportunity of sampling a large number of colonies at each of the visited sites (minimum number of colonies sampled per site $n=3$, see Table 6.8) as well as the number of sampling sites (a total of 4 areas) will allow the proposed intra-colonial, inter-colonial and inter-site analysis as originally planned.

(2) The quantification of Particulate Organic Matter (POM) uptake by L. pertusa in experimental chambers at different current speeds.

During the cruise it was possible to carry out a total number of 8 experimental trials. This level of data will enable a good trophic ecology assessment of *L. pertusa* to be completed.

6.3.4 Future analysis planned

To place the experimental results into a wider context ('scaling up'), we would like to complement our results with the abiotic parameters of the study areas where the coral samples were originally collected. We will use the CTD, ADCP and mooring data as well as the results from the SAPS filters.

We would also like the opportunity to complement our experimental results with the results of the ecophysiological experiments carried out on board by HWU, (e.g. respiration rates and acidification treatments under different feeding conditions) on *L. pertusa*. We also would like to add value with our results and take the opportunity to complement with the sponge feeding ecology experiments conducted by Georgios Kazanidis (University of Aberdeen). We would like to compare consumption rates of an active suspension feeder (sponge) with the results obtained for the passive suspension feeder *L. pertusa*.

We have also identified a potential way to relate our experimental results to the natural sampled environments. For example, the information obtained on coral density could be used to obtain an approximate idea on the consumption rates of these animals in the system, and the trophic impact they can have in the adjacent water layers. This information could be obtained from the results collected during the video transects.

Scientific collaborations established during and beyond the JC073 cruise

A collaborative work has been discussed during the cruise with Prof. J. M. Roberts (HW University) and Dr S. Birchenough (CEFAS) to analyze the results of the optical surveys (e.g. SPI Camera and video data), which will provide complementary information on different scales and to place experimental results into wider context.

A series of histochemical analyses of *L. pertusa* samples will be developed in collaboration with the Dr. P. Saucedo and Dr. C. Jaramillo from the Centro de Investigaciones Biológicas del Noroeste (CIBOR, Mexico).

Samples for skeletal density analyses will be send to Dr. Marina Carreiro (University of Azores) as part as a collaborative work already on going.

6.4 Analysis of DMS and DMSP (Penelope Donohue)

Dimethylsulphoniopropionate (DMSP) and its enzymatic cleavage product dimethylsulphide (DMS) have been shown to contribute significantly to the global sulphur cycle and climate and their production in phytoplankton and macroalgae are well studied. However, the source, distribution and physiological function of DMS and DMSP in marine invertebrates have received little attention. Benthic tropical coral reef organisms have been found to be an important localised source of DMS (see Broadbent & Jones 2004) and DMSP has been shown to mediate important ecological interactions between marine organisms, for example foraging in reef fish (DeBose *et al.* 2008). In addition, DMSP has been shown to occur in several other macroinvertebrates, including examples with and without endosymbiotic algae (Van Alstyne & Puglisi 2007). Endosymbionts are thought to be a major source of DMSP and diet may be an important source for those organisms that lack endosymbionts. Several cellular functions for DMSP in algae have been proposed, including cryoprotectant, antioxidant and osmolyte (Andreae 1990, Sunda *et al.* 2002) and DMSP levels have been shown to increase in marine invertebrates in response to environmental stress (Yost *et al.* 2010). In the context of global climate change, it is hypothesised that DMSP may play an important role in combating the adverse effects of rising temperatures and ocean acidification in marine organisms.

The following project will determine the primary source of DMSP and DMS in *Lophelia pertusa* (i.e. from diet or produced by the coral). In addition, it will compare the production of DMSP and DMS in corals incubated in a control treatment (9°C, CO₂ = 380 ppm) with those in (1) a high temperature treatment (12°C, CO₂ = 380 ppm) (2) a high CO₂ treatment (9°C, CO₂ = 750 ppm) and (3) with a combination of high temperature and high CO₂ (12°C, CO₂ = 750 ppm). The treatments were chosen to reflect the increase in ocean temperature and atmospheric CO₂ predicted to occur by the end of the century.

6.4.1 Methods

The experimental treatments were nominally maintained at 9°C and 380 ppm (control), 9°C and 750 ppm (increased CO₂), 12°C and 380 ppm (increased temperature) and 12°C and 750 ppm (increased temperature and CO₂). These levels were chosen to mimic predicted values that may be encountered by benthic organisms under ocean acidification scenarios (750 ppm) and increased temperature (12°C). Fragments of *L. pertusa* were collected from two distinct sites (Mingulay and Logachev). Five colonies of *Lophelia pertusa* were identified from each population (Mingulay and Logachev) and even numbers of fragments from each colony (four fragments) and each population were allocated to one of the four treatments. In addition, each of the four treatments had a replicate that was fed (corals had access to food naturally available in the seawater) and unfed (no particulate food was available to corals for the duration of the experiment), see Section 6.2.2b. Prior to the start of the experiment one polyp from each

fragment, used in the experiment, was removed and immediately frozen in liquid nitrogen to obtain T₀ information.

Temperature, salinity and pH were monitored in collaboration with HWU (see methods section in coral physiology for full details). In addition, water samples were taken from the experimental tanks throughout the duration of the experiment for analysis of dissolved inorganic carbon (DIC) and total alkalinity (TA).

a. DMS(P) coral sample preparation: Dimethylsulphide (DMS) and dimethylsulphoniopropionate (DMSP) are analysed in algae and water using gas chromatography. Samples of seawater from the experimental tanks and coral polyps were sampled throughout the experiment and will be transported back to the University of Glasgow's DMSP analytical facility. The method here describes sample preparation such that DMS and DMSP can be analysed as one.

The following equipment was used:

- 50 ml crimp top vials
- Pharma-Fix 20 mm crimp top lids
- 20 mm vial crimper
- NaOH (10M concentration – 40 g pellets in 100 ml water)
- Pasteur pipette
- Milli-Q water
- Mass balance (resolution: at least 2 decimal places)
- Forceps

Protocol:

1. Add ~2 ml 10 M NaOH to each vial and fill to the shoulder with Milli-Q water
2. Break one polyp off the colony, record the mass and add to the vial
3. Fill the vial to the brim with Milli-Q water
*Fill enough to ensure **NO** bubbles remain in the vial once crimped*
4. Quickly place the lid on the vial and crimp shut
To crimp: be firm but do not over tighten
NaOH hydrolyses DMSP to DMS – DMS is volatile gas therefore DMS will be lost if the vial is not sealed quickly and correctly

b. DMS(P) mesocosm water sample preparation: Equipment required as listed above with in addition:

- Water filtering holder

Protocol:

1. Add ~2 ml 10M NaOH to each vial to be used (2 per water sample). Label each set of two with DMSPd or DMSPp

2. Fill all DMSPp vials to the shoulder with Milli-Q water
3. Place a filter in the filter holder
4. Withdraw ~10 ml of sample water using a glass syringe and rinse. Discard water and repeat
5. Withdraw >50 ml sample water and invert syringe to remove all air bubbles. Eject water until at the 50 ml line ensuring no air bubbles remain in the syringe
6. Attach the filter holder to the syringe and filter 50 ml into the DMSPd vial. Fill to the brim with Milli-Q and crimp

A white precipitate will form

7. Using forceps, transfer the filter to the DMSPp vial, fill to the brim with Milli-Q water and crimp

c. DMSP Incubations: In addition to measuring the DMS(P) in the experimental water and coral polyps, incubations in air-tight chambers were performed with coral fragments from each treatment. These incubations will allow the rate of DMS(P) release to be calculated and will ascertain the source of DMSP (i.e. the coral polyp or the coral's food source).

Fragments from each treatment (nominally 9 °C, 380 ppm, 12 °C, 380 ppm, 9 °C, 750 ppm, 12 °C, 750 ppm, N = 8) were placed in incubation chambers (volume = 220 ml) containing seawater corresponding to the respective experimental conditions (380 ppm or 750 ppm). Temperature of the incubation chambers was maintained using a water bath, water of which was re-circulated through an external water chiller (HWU) set to the respective experimental conditions (9 °C or 12 °C). For incubations with coral fragments from the 'unfed' treatment, seawater was filtered (0.2 µm) to ensure removal of all the particulates. Within each incubation chamber the water was stirred continuously using a submerged magnetic stirrer. After coral fragments were placed into the incubation chambers they were given two hours to recover from any imposed handling stress, after which the lid was sealed making the chamber air-tight and the coral fragments were left for a further two hours. Water was sampled for DMS(P) before and after the incubation period and processed as per the methods described above for sampling mesocosm seawater. The fragments used in the incubations will be taken back to HWU to determine the tissue mass of each fragment in order to normalise data collected on DMS(P).

6.4.2 Results and initial conclusions

All of the samples will be shipped back to the University of Glasgow for analysis. Figures 1 & 2 detail all the samples collected for analysis.

Treatment	Samples	Sampling points (days):			
		TØ	10	14	21
FED: 9°C & 12°C(380, 750)	Water Samples taken:	5 replicates	5 replicates	5 replicates	5 replicates
	Polyp samples taken:	5 replicates	5 replicates	5 replicates	5 replicates
NON-FED: 9°C , 380 ppm	Water samples taken:	-	5 replicates	-	DEAD*
	Polyp samples taken :	-	5 replicates	-	DEAD*
9°C, 750 ppm	Water samples taken:	-	DEAD*	-	DEAD*
	Polyp samples taken:	-	5 replicates	-	5 replicates
12°C (750, 380 ppm)	Water samples taken:	-	5 replicates	-	5 replicates
	Polyp samples taken:	-	5 replicates	-	5 replicates

Figure 6.8 Schematic illustrating the *Lophelia pertusa* and experimental water samples taken during the 21 day exposure to high-CO₂ and increased temperature. *indicates corals had died during the experiment.

Treatment	Number of replicates
FED: 9 °C 380 ppm	8
FED: 12 °C, 380 ppm	4
FED: 9 °C, 750 ppm	6
FED: 12 °C, 750 ppm	8
UNFED: 9 °C, 750 ppm	8
UNFED: 12 °C, 750 ppm	8

Figure 6.9. Schematic illustrating the water samples collected for DMS(P) analysis after incubations. TØ samples were collected for each treatment at the beginning of each incubation.

6.5 Microbiological sampling and analysis (Anne Cotton & Geoff Cook)

The symbiotic microbial assemblages associated with scleractinian corals are thought to perform a number of important functions for the holobiont (Ainsworth *et al.* 2010). Whilst much research has focused on microorganisms associated with shallow-water corals confined to the tropics, comparatively little is known about the composition and function of microbial communities associated with deep-water coral species (Kellogg *et al.* 2009, Neulinger *et al.* 2009, Schöttner *et al.* 2009). Of the few studies that have examined the microbial assemblages of the cold-water coral *Lophelia pertusa*, most have been conducted in the Gulf of Mexico (Kellogg *et al.* 2009; Galkiewicz *et al.* 2011) and Norway (Neulinger *et al.* 2008; Neulinger *et al.* 2009; Schöttner *et al.* 2009; Schöttner *et al.* 2012).

Despite extensive *Lophelia* reefs inhabiting the numerous areas across the northeast Atlantic Ocean, the microbial communities associated with these corals have only been the focus of a single investigation (Großkurth 2007). Whilst providing some initial insight into the composition of coral-associated bacterial communities from the Mingulay Reef Complex this study presents limited information because it did not taxonomically identify any of the bacteria. Further, Großkurth (2007) used coral fragments obtained by dredges, corers and video-grabs—collection devices that are not ideal for investigating the composition of coral-associated microbial communities because these instruments do not prevent cross-contamination among different coral fragments or between coral fragments and sediment, fauna, or the overlying water column (Kellogg *et al.* 2009). Lastly, Großkurth (2007) only examined fragments of *L. pertusa* obtained from the Mingulay Reef Complex. However, *L. pertusa* is found at numerous sites across the NE Atlantic such as Rockall Bank.

The geographical distances separating the Mingulay Reef Complex and various *Lophelia* reefs around Rockall Bank provide a unique opportunity for examining the biogeography of *Lophelia*-associated microbes. Quantifying environmental attributes of these areas affords the opportunity to identify key abiotic variables influencing the structure and function of *Lophelia*-associated bacteria. Because coral tissue is required to study the associated bacterial communities, collection efforts across this geographical area also enable investigating genetic connectivity among the cnidarian hosts. Consequently, a study design that employs collection methods to prevent cross-contamination among samples as well as analytical techniques that increase the taxonomic resolution would be useful.

Seeking a deeper understanding of the taxonomic composition, diversity, and biogeographical distribution of microbial communities associated with *L. pertusa* naturally leads into probing their function within the coral holobiont. To date, no investigations have examined symbiotic bacterial communities for the presence and activity of genes responsible for nitrogen cycling. Culture-independent techniques have already revealed functional attributes about the microbial communities in terrestrial sediments and have the potential to improve our understanding of the *Lophelia*-associated microbial communities (Smith *et al.* 2007; Dong *et al.* 2009).

It has also been established that bacterial communities associated with corals can be distributed among different tissue groups. A standard method used to characterize the distribution of microbes on and within coral tissues is fluorescent *in situ* hybridisation (FISH). This technique was recently used to study the location of bacterial classes (e.g., *Alphaproteobacteria* and *Gammaproteobacteria*) in *Lophelia* but has the potential to locate individual bacterial strains (Neulinger *et al.* 2008). Therefore, FISH presents a particularly powerful technique, especially when used in conjunction with high-resolution taxonomic information generated from deep sequencing of the coral microbiome.

In an attempt to expand the successes of previous investigations, this project aimed to further the current understanding of deep-water coral-associated microbial communities by addressing some of the questions outlined above. Using a remotely operated vehicle (ROV), fragments of *L. pertusa* were obtained from various sites within the Mingulay Reef Complex and around Rockall Bank. These sites were specifically chosen because of habitat heterogeneity, depth gradients, and for enabling small- and large-scale geographical comparisons.

Various culture-independent techniques, such as next generation sequencing (NGS), FISH, and Length-Heterogeneity PCR (LH-PCR) will be used to characterize the bacterial assemblages associated with *L. pertusa*. Each *Lophelia* colony sampled will also be genotyped in order to investigate genetic connectivity as well as patterns of association between microbial community(-ies) and their cnidarian hosts (Morrison *et al.* 2008). Aspects of *Lophelia*-associated microbial ecology will also be assessed by screening for the presence and diversity of functional genes related to nitrogen cycling. Detailed environmental metadata collected from each sample site will contribute to the development of predictive models and guide the formation of testable hypotheses that explain the roles of abiotic variables in establishing, maintaining, and altering the physiology of the deep-water coral holobiont.

6.5.1 Methods

a. Sample acquisition: Fragments of *L. pertusa* were opportunistically collected from multiple colonies inhabiting three different geographic locations in the northeast Atlantic Ocean: the Mingulay Reef Complex, the Logachev Carbonate Mounds, and the *Pisces* 9 Site (Table 6.10). Using the RRS *James Cook* as a platform, the deep-water ROV *Holland I* was outfitted with a custom design and custom built sampling chamber (Figures 6.10 and 6.11). Microbiological sampling positions at Mingulay are illustrated in Figure 6.12 and at the Logachev Mounds in Figure 6.13.

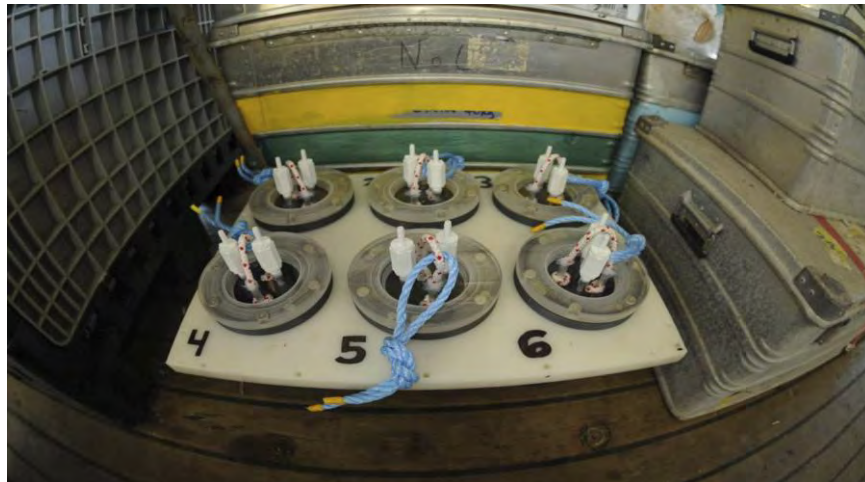

Figure 6.10 The custom-made coral sampler used during the JCO73 Changing Oceans Expedition. The sampler is composed of six individual canisters with magnetically sealing lids. All canisters are retained in a polypropylene sheet to create an array. The array is then bolted to the top of standard biological box.



Figure 6.11 The sampling array, nested within a standard biological box, attached to the forward starboard footprint of the ROV *Holland-1*.

Table 6.10 Spatial and temporal metadata from sites where microbiological samples of *L. pertusa* were collected during the JCO73 research cruise. Positioning information (degrees decimal minutes) indicates the location of both the RRS *James Cook* and ROV *Holland-1* when the ROV arrived at the seabed, thereby marking the beginning of each transect. M, Mingulay; M(BR), Mingulay (Banana Reef); LM, Logachev Mounds; P9 *Pisces* 9.

Date (2012)	Site	ROV Dive #	Station #	Ship Lat. (at bottom)	Ship Long. (at bottom)	Sub Lat. (at bottom)	Sub Long. (at bottom)	Ship Sounding (m)	UTC Time (ROV at bottom)
22/5	M	5	27	56°49.3	-7°23.7093	56°49.0	-7°23.7022	131	16:48:35
23/5	M(BR)	7	39	56°48.1	-7°27.0293	56°48.1	-7°27.0066	155	16:00:34
24/5	M	10	46	56°49.4	-7°23.7235	56°49.4	-7°23.6922	123	16:16:09
27/5	LM	13	61	55°33.5	-15°39.3229	55°33.5	-15°39.3431	563	16:29:22
28/5	LM	16	75	55°33.0	-15°37.9173	55°33.0	-15°37.9498	793	18:24:43
30/5	LM	19	95	55°29.6	-15°49.3870	55°29.7	-15°49.3762	857	12:12:38
4/6	LM	25	126	55°34.3	-15°47.2824	55°34.3	-15°47.2471	800	15:35:39
5/6	LM	28	141	55°34.0	-15°39.2128	55°34.0	-15°39.2640	706	12:38:29
7/6	P9	32	147	57°35.7	-14°30.7484	57°35.7	-14°30.7576	266	19:42:54
8/6	P9	34	151	57°58.2	-14°01.2664	57°58.2	-14°01.2932	229	15:15:48
13/6	M	40	179	56°49.3	-7°25.7339	56°49.0	-7°25.7578	118	12:25:54

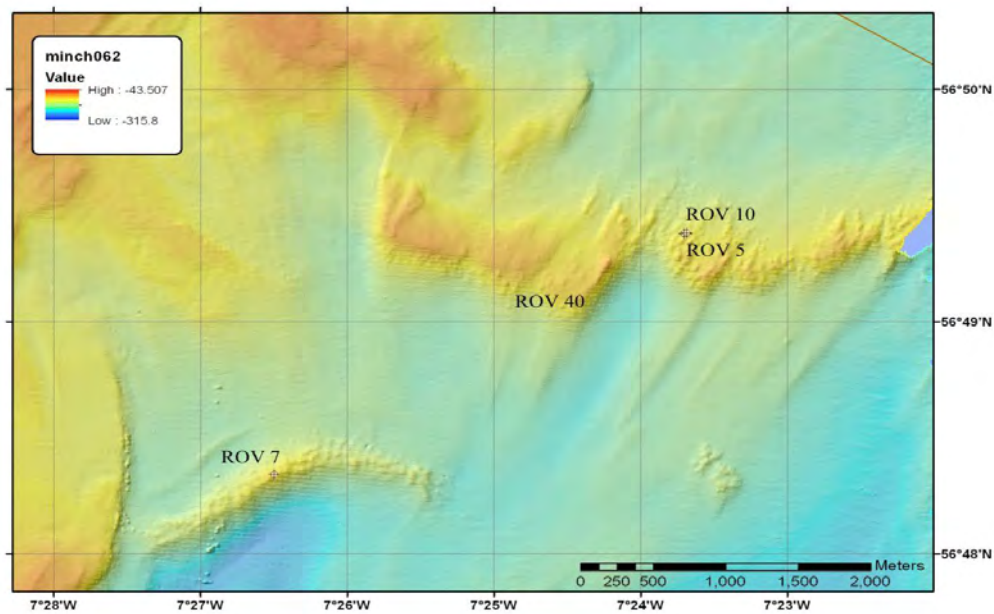

Figure 6.12: A benthic relief map showing the location and relative depths of those areas where *L. pertusa* fragments were collected from the Mingulay Reef Complex.

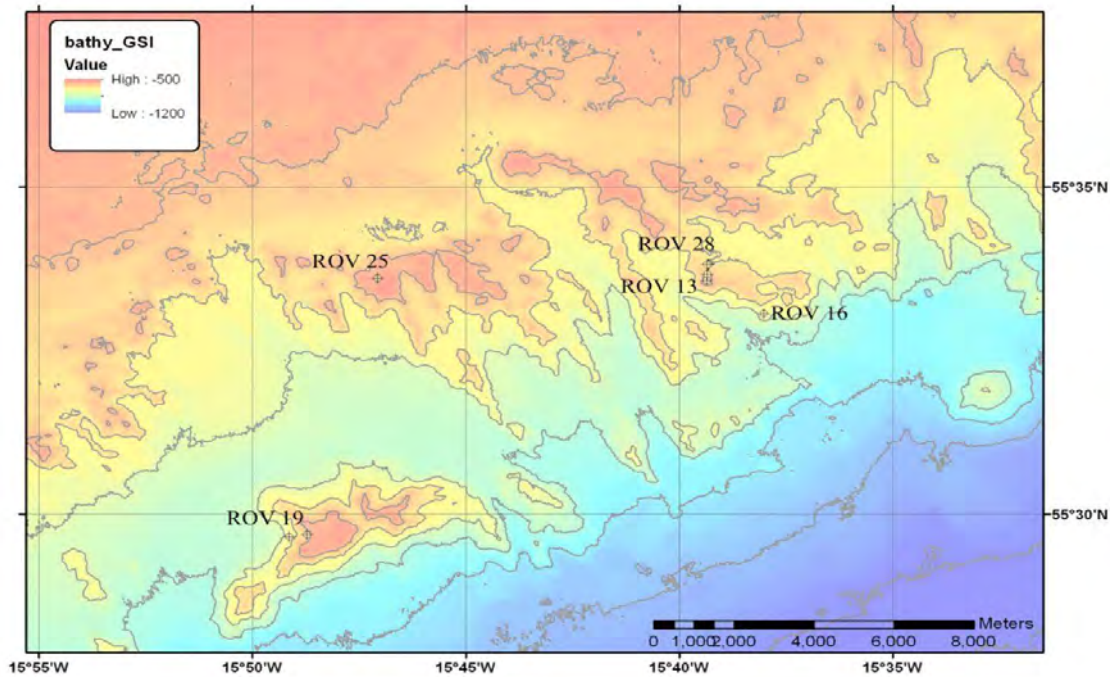

Figure 6.13 A bathymetric map depicts the location and relative depths of those areas where *L.pertusa* fragments were collected from the Logachev Carbonate Mounds.

The custom-built sampling unit, herein referred to as “the sampler”, enabled triplicate collections of coral fragments from individual *Lophelia* colonies while simultaneously preventing cross-contamination among intra-colony coral samples, between inter-colony replicates, and from the surrounding environment.

Before being loaded onto the ROV, all components the sampler that could potentially contact coral fragments were cleaned with a 10% bleach solution followed by diluted ethanol (70% ETOH) and finally rinsed with three separate washes of MilliQ water. Each canister was then over-filled with MilliQ water and sealed. Sealing full canisters served to counteract the negative, potentially catastrophic, effects of extreme atmospheric pressures encountered at all sampling depths. As a precaution, components of the ROV that would contact the coral fragments (e.g., the slurp gun) were also cleaned as previously described.

When a *Lophelia* colony was identified for sampling the ROV would come to a full stop in front of the colony. If necessary, the ROV would remain motionless before commencing with specimen collection to allow ample time for any disturbed sediment to settle out of the water column. When conditions were deemed acceptable, the port and starboard tooling skids were extended from underneath the ROV. The starboard manipulator arm was then used to remove the lid from canister #1 in the array. This was achieved by grasping a knot made in positively buoyant polypropylene rope that was tied to each lid (Figure 6.12). After removing a lid, the MilliQ water inside a canister was immediately displaced by dense ambient seawater. This could be visually confirmed by watching freshwater rise out of each canister (Figures 6.13 & 6.14).

Sample collection would begin only when no additional freshwater could be seen escaping a canister.

With a lid securely clenched by the starboard manipulator arm, the port manipulator arm was engaged and used to prepare the vacuum suction mechanism, herein referred to as the “slurp gun” (Figure 6.14). Mild suction was generated via the slurp gun mechanism and used to retain small coral pieces fragmented off the distal tips of a *Lophelia* colony. A metal screen was positioned behind the acrylic sampling container fixed at the terminus of the vacuum hose. This mesh screen prevented coral fragments from being sucked down the length of the vacuum hose and deposited in an bio-box aquarium at the rear of the ROV.

Selection of a *Lophelia* colony was predicated on size, accessibility, habitat type, and overall appearance of the colony. For example, colonies needed to be large enough to ensure triplicate samples could be secured. Further, three different locations within each colony were desired: (1) Cans 1/4 contained distal fragments collected from the colony’s base; (2) Cans 2/5 contained distal fragments collected from the middle of colony; and (3) Cans 3/6 contained distal fragments collected from the colony’s apex (Figure 6.15). Colonies also needed to be situated on the reef in such a way as to permit safe, relatively easy access. The primary concern regarding accessibility was preventing damage to other marine organisms and disturbance of the sediment by the ROV.



Figure 6.12 The starboard manipulator arm grasps positively buoyant rope and removes a lid from one of the canisters in the sampling array. Freshwater is immediately displaced by seawater, as can be seen by the cloudy disturbance next to the arrow in the above photograph.



Figure 6.13: Moving the lid away from each canister allows the complete overturn of freshwater to ambient seawater. Freshwater rising out of canister #2 can be seen next to the arrow in the above photo.



Figure 6.14 With a lid held securely by the starboard manipulator arm, the port manipulator arm grasped the ROV's slurp gun—seen in the upper left corner of the above photograph—in preparation for collecting live coral samples.

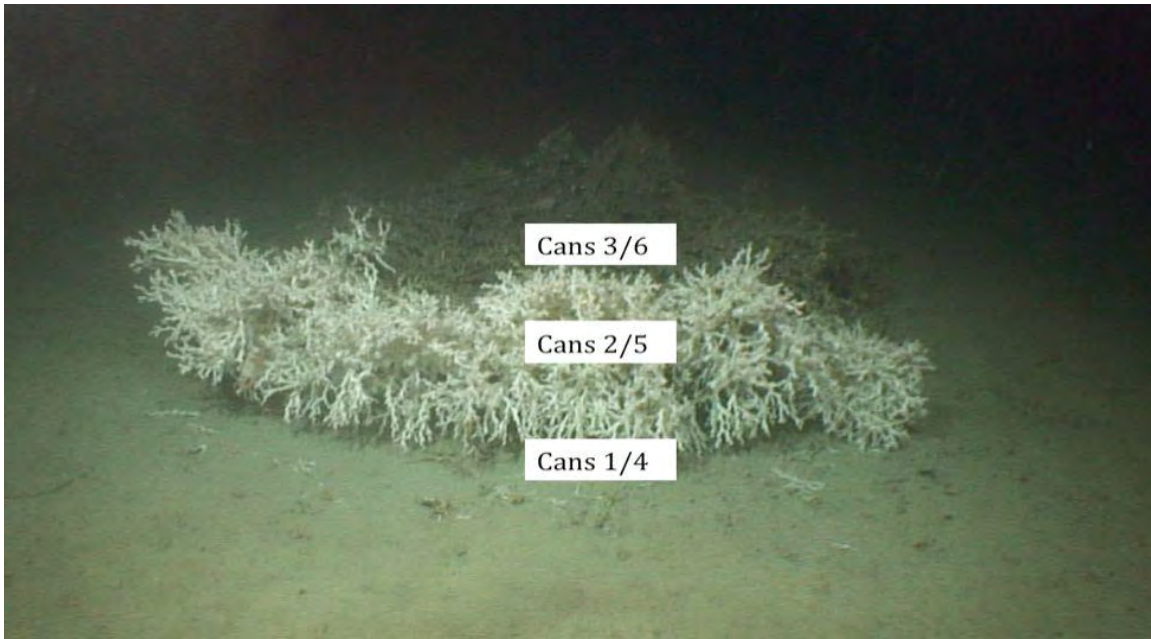

Figure 6.15 Fragments of live *Lophelia* were collected from three different areas within each colony. Distal branches growing near the base of a colony were placed in either canister 1 or 4; distal branches growing mid-colony were placed in either canister 2 or 5; and distal fragments growing near the apex of a colony were placed in canister 3 or 6.

Triplicate samples were collected from, at most, two coral colonies during ROV dives 5, 19, 28, and 32 (Table 6.11). Either vertical or horizontal spatial gradients separated the colonies targeted for sampling. For example, at the Logachev Carbonate Mounds the first colony was always off-mound, in deeper water, while the second colony was located on-mound in shallower water. When significant depth gradients within a site did not exist, such as at the Mingulay Reef Complex, a horizontal distance was inserted between sampling events. An *a priori* assumption about these spatial gradients is they span different benthic habitats and exploit some of the variability in the associated geological, hydrological, and physicochemical attributes that *L. pertusa* encounters. Due to various environmental limitations, such as surface conditions, or logistical restrictions, such as time of day or length of transect, only a single *Lophelia* colony was sampled during dives 7, 10, 13, 16, 25, and 34 (Table 6.11).

If these physical and spatial requirements were satisfied then the ROV would commence sampling. Beginning at the base of a colony, the slurp gun would be moved into position and gentle suction applied. The manipulator arm would then graze the mouth of the slurp gun's acrylic extension tube across the distal portions of the coral colony to liberate multiple fragments from a single, yet highly focused, area (Figure 6.15). These fragments would slowly move down the acrylic cylinder until they encountered the metal screen (Figure 6.16).

Once 5-10 coral fragments had been obtained, the slurp gun was positioned over the mouth of a dedicated canister containing ambient seawater (Figure 6.17). Vacuum suction was stopped which allowed the fragments to fall into a canister. The slurp gun was then moved away from

the canister into the water column while the starboard manipulator arm replaced the container's lid (Figures 6.18-21). Full suction was applied to the slurp gun before sampling the next area of a *Lophelia* colony. This precaution was taken in an attempt to remove residual biological material from the mesh screen. This entire process was repeated twice more until all three intra-colony samples had been secured.

Table 6.11 Spatial and temporal data associated with all microbiological samples of *Lophelia pertusa* obtained during the JCO73 expedition. All information was recorded at the moment of collection.

Canister	Sample Name	Dive Event #	Date	GMT	Ship Long.	Ship Lat.	Sub Long.	Sub Lat.	Depth (m)
1	ROV5_C1	31	5.22.2012	21:07:54	-7°23.68728	56°49.35744	-7°23.703618	56°49.37754	133
2	ROV5_C2	32	5.22.2012	21:26:59	-7°23.68806	56°49.35888	-7°23.70348	56°49.37757	133
3	ROV5_C3	33	5.22.2012	21:43:03	-7°23.68883	56°49.359	-7°23.703402	56°49.377	133
4	ROV5_C4	34	5.22.2012	22:06:14	-7°23.68692	56°49.35834	-7°23.702838	56°49.380108	131
5	ROV5_C5	35	5.22.2012	22:17:19	-7°23.68746	56°49.35792	-7°23.70219	56°49.380072	131
6	ROV5_C6	36	5.22.2012	22:34:56	-7°23.6877	56°49.35852	-7°23.70117	56°49.380078	131
1	ROV7_C1	2	5.23.2012	18:21:59	-7°26.52426	56°48.3282	-7°26.493918	56°48.341652	132
2	ROV7_C2	3	5.23.2012	18:33:53	-7°26.5233	56°48.32904	-7°26.494278	56°48.342012	132
3	ROV7_C3	4	5.23.2012	18:43:56	-7°26.52258	56°48.32886	-7°26.49426	56°48.341928	132
4	No sample	No sample	No sample	No sample	No sample	No sample	No sample	No sample	No sample
5	No sample	No sample	No sample	No sample	No sample	No sample	No sample	No sample	No sample
6	No sample	No sample	No sample	No sample	No sample	No sample	No sample	No sample	No sample
1	ROV10_C1	10	5.24.2012	17:43:39	-7°23.70582	56°49.3683	-7°23.682972	56°49.381122	128
2	ROV10_C2	11	5.24.2012	17:46:09	-7°23.70606	56°49.36806	-7°23.68368	56°49.38126	128
3	ROV10_C3	12	5.24.2012	17:51:06	-7°23.70612	56°49.3683	-7°23.684112	56°49.381392	128
4	No sample	No sample	No sample	No sample	No sample	No sample	No sample	No sample	No sample
5	No sample	No sample	No sample	No sample	No sample	No sample	No sample	No sample	No sample
6	No sample	No sample	No sample	No sample	No sample	No sample	No sample	No sample	No sample
1	ROV13_C1	13	5.27.2012	19:34:29	-15°39.336462	55°33.571422	-15°39.335622	55°33.571098	589
2	ROV13_C2	14	5.27.2012	19:47:59	-15°39.336162	55°33.571422	-15°39.335262	55°33.571662	589
3	ROV13_C3	5	5.27.2012	19:52:46	-15°39.33564	55°33.57153	-15°39.33564	55°33.57153	589

4	No sample	No sample	No sample	No sample	No sample	No sample	No sample	No sample	No sample
5	No sample	No sample	No sample	No sample	No sample	No sample	No sample	No sample	No sample
6	No sample	No sample	No sample	No sample	No sample	No sample	No sample	No sample	No sample
1	ROV16_C1	12	5.28.2012	19:34:29	OFOPS Failed	OFOPS Failed	-15°38.00502	55°33.06738	753
2	ROV16_C2	13	5.28.2012	19:47:59	OFOPS Failed	OFOPS Failed	-15°38.00448	55°33.06492	753
3	ROV16_C3	14	5.28.2012	19:52:46	OFOPS Failed	OFOPS Failed	-15°38.00448	55°33.06492	753
4	No sample	No sample	No sample	No sample	No sample	No sample	No sample	No sample	No sample
5	No sample	No sample	No sample	No sample	No sample	No sample	No sample	No sample	No sample
6	No sample	No sample	No sample	No sample	No sample	No sample	No sample	No sample	No sample
1	ROV19_C1	6	5.30.2012	14:57:13	-15°49.14288	55°29.65116	-15°49.126302	55°29.65761	769
2	ROV19_C2	7	5.30.2012	15:03:32	-15°49.13862	55°29.6511	-15°49.12641	55°29.657292	769
3	ROV19_C3	8	5.30.2012	15:09:57	-15°49.1403	55°29.65098	-15°49.125018	55°29.65764	769
4	ROV19_C4	17	5.30.2012	17:03:47	-15°48.69186	55°29.67762	-15°48.711612	55°29.689788	604
5	ROV19_C5	18	5.30.2012	17:10:37	-15°48.69282	55°29.67804	-15°48.712248	55°29.68917	604
6	ROV19_C6	19	5.30.2012	17:16:00	-15°48.69084	55°29.67792	-15°48.71235	55°29.688678	604
1	ROV25_C1	2	6.4.2012	18:54:00	-15°47.05428	55°33.6105	-15°47.05548	55°33.60897	551
2	ROV25_C2	3	6.4.2012	18:59:00	-15°47.0523	55°33.60864	-15°47.05548	55°33.60894	551
3	ROV25_C3	4	6.4.2012	19:01:00	-15°0.784174	55°0.560156	-15°0.7842382	55°0.560154	551
4	No sample	No sample	No sample	No sample	No sample	No sample	No sample	No sample	No sample
5	No sample	No sample	No sample	No sample	No sample	No sample	No sample	No sample	No sample
6	No sample	No sample	No sample	No sample	No sample	No sample	No sample	No sample	No sample
1	ROV28_C1	1	6.6.2012	13:49:02	-15°39.28122	55°33.8421	-15°39.29832	55°33.820908	677
2	ROV28_C2	2	6.6.2012	13:51:58	-15°39.27972	55°33.84258	-15°39.300342	55°33.816702	677
3	ROV28_C3	3	6.6.2012	13:57:23	-15°39.2811	55°33.84162	-15°39.34104	55°33.816582	677
4	ROV28_C4	14	6.6.2012	15:21:17	-15°39.3045	55°33.69528	-15°39.3282	55°33.668598	582
5	ROV28_C5	15	6.6.2012	15:24:05	-15°39.30264	55°33.69432	-15°39.328248	55°33.66879	582

6	ROV28_C6	16	6.6.2012	15:26:35	-15°39.3036	55°33.69486	-15°39.328878	55°33.668862	582
1	ROV32_C1	1	6.7.2012	20:14:30	-14°30.69648	57°35.64906	-14°30.72528	57°35.63445	269
2	ROV32_C2	2	6.7.2012	20:14:30	-14°30.69648	57°35.64906	-14°30.72528	57°35.63445	269
3	ROV32_C3	3	6.7.2012	20:14:30	-14°30.69648	57°35.64906	-14°30.72528	57°35.63445	269
4	ROV32_C4	4	6.7.2012	21:08:43	-14°30.67794	57°35.58294	-14°30.683412	57°35.56317	273
5	ROV32_C5	5	6.7.2012	21:20:20	-14°30.67956	57°35.58282	-14°30.68274	57°35.56227	273
6	ROV32_C6	6	6.7.2012	21:22:53	-14°30.6798	57°35.58288	-14°30.683622	57°35.562798	273
1	ROV34_C1	1	6.8.2012	16:02:26	-14°1.35042	57°58.32342	-14°1.39275	57°58.319838	233
2	ROV34_C2	2	6.8.2012	16:04:50	-14°1.35588	57°58.32492	-14°1.393908	57°58.320288	233
3	ROV34_C3	3	6.8.2012	16:08:39	-14°1.35426	57°58.32276	-14°1.392828	57°58.32024	233
4	No sample	No sample	No sample	No sample	No sample	No sample	No sample	No sample	No sample
5	No sample	No sample	No sample	No sample	No sample	No sample	No sample	No sample	No sample
6	No sample	No sample	No sample	No sample	No sample	No sample	No sample	No sample	No sample
1	ROV40_C1_FISH	4	6.13.2012	16:07:20	-7°24.4616	56°49.0774	-7°24.4616	56°49.0771	122
2	ROV40_C2_FISH	5	6.13.2012	16:14:51	-7°24.4610	56°49.0774	-7°24.4610	56°49.0770	122
3	ROV40_C3_FISH	6	6.13.2012	16:19:36	-7°24.4615	56°49.0770	-7°24.4615	56°49.0770	122
4	ROV40_C4_FISH	8	6.13.2012	18:45:23	-7°23.9225	56°49.3455	-7°23.46732	56°49.3348	148
5	ROV40_C5_FISH	9	6.13.2012	18:47:46	-7°23.9224	56°49.3457	-7°23.46732	56°49.3348	148
6	ROV40_C6_FISH	10	6.13.2012	18:51:52	-7°23.9219	56°49.3456	-7°23.46732	56°49.3348	148



Figure 6.15 The acrylic extension tube of the suction sampling mechanism is gently grazed across a colony of *L. pertusa*. A mild vacuum lifts small coral fragments away from the substrate and holds them against a mesh screen positioned at the base of the extension tube.



Figure 6.16 Fragments of *L. pertusa* being held against a metal mesh screen at the base of the acrylic extension tube.



Figure 6.17 The slurp gun and associated coral fragments are positioned in the mouth of a dedicated canister. As can be seen in the above photograph, the coral fragments gently slide into a container when vacuum suction is stopped.



Figure 6.18 The slurp gun is moved away from the canister to allow replacement of the lid.



Figure 6.19 The self-seating lid easily adheres to the open-end of the canister.



Figure 6.20 With only a modest amount of encouragement from the starboard manipulator arm, the lid is pushed into position to create a watertight seal that retains the *Lophelia* fragments at constant ambient water temperature and salinity.



Figure 6.21 The slurp gun is pointed into the water column and full suction applied. This procedure serves to remove any residual biological material from the mesh screen before proceeding to collect additional samples.

b. Initial processing of coral fragments: After each dive, and immediately after the ROV returned and was secured to the deck, the sampling array was removed and transferred to a constant temperature room maintained at 9°C in darkness. The temperature and salinity of seawater retained in the samplers' canisters were assessed with a standard probe prior to removal from the constant temperature room. The average (mean \pm SD) temperature of retained seawater was 9.3°C \pm 0.2°C while average salinity was 35.5 ‰ \pm 0.5 ‰.

The contents of each canister were then transferred to a dedicated, pre-sterilized 2 L plastic tub (Figure 6.22). Each tub was rinsed in triplicate with site water from a dedicated canister. This step was always performed before coral fragments and seawater were transferred to a tub. A high-resolution digital photograph of the coral fragments was then taken to provide a visual record of each sample's appearance, including color of the coral fragments and the presence of organisms other than *Lophelia*. All coral fragments were then split into individual polyps using sterile wire cutters, tweezers, and needle-nose pliers.



Figure 6.22 Multiple coral fragments collected from a *Lophelia* colony.

c. Genetic sampling: Two intact polyps from each canister were preserved for genetic analyses of the *Lophelia* colonies sampled. Each polyp was photographed and then separately preserved on a circle of a QIAcard FTA® Four Spots card (Qiagen, Crawley, UK) consisting of special paper impregnated with preservative buffer designed to stabilize and preserve DNA without refrigeration (Figures 6.23-24). Tissue was removed from each polyp using sterilized tweezers, transferred to a dedicated circle on the FTA card, and smeared into the paper. Smearing was achieved by using the tweezers to mix the tissue onto the circle then folding the protective flap down over the card and gently rubbing. FTA cards were left to air dry before being stored in an airtight plastic bag.

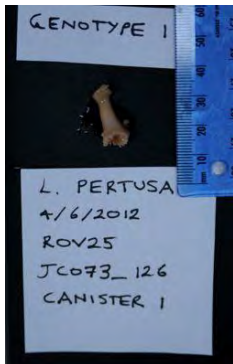

Figure 6.23 Coral fragments were pruned to generate individual polyps. At least two polyps per sample were preserved for coral genotyping and population connectivity analyses.

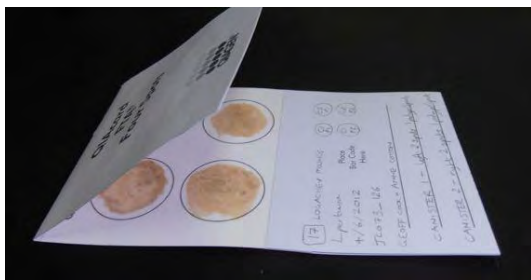

Figure 6.24 QIAcard FTA® Four Sports card. DNA from individual coral polyps was smeared onto individual circles, thereby preserving this material for subsequent genetic analysis.

d. FISH sampling: One polyp from each canister was preserved for FISH analysis of associated Gram-positive bacteria and an additional polyp preserved separately for analysis of coral-associated Gram-negative bacteria.

Gram-positive: Individual coral polyps were photographed then immediately immersed in a 50% (vol/vol) solution of ethanol (ETOH) in Phosphate buffered saline (PBS). These samples were immediately transferred to a -20 °C freezer where they were stored upright.

Gram-negative: Polyps were photographed then immediately immersed in 4% paraformaldehyde (PFA) in PBS. After a three-hour incubation, PFA was gently removed by aspirating with a Pasteur pipette. The polyp was then immersed in PBS wash for one minute after which this solution was removed via gentle pipetting. This process was repeated two more times to ensure all residual PFA was removed. Finally, the polyp was immersed in 50% (vol/vol) solution of ethanol in phosphate buffered saline (PBS) and stored at -20°C.

e. Metagenomics & transcriptomic sampling: Approximately 10 live *Lophelia* polyps from fragments in one of the three canisters collected per coral colony were combined into a sterile 50 ml falcon tube and immersed in approximately 25 ml of RNALater™ (Ambion, U.S.A.). RNALater™ is a solution that has been previously used to successfully preserve both RNA and DNA from samples of *L. pertusa*

(Morrison 2011 pers. comm., Kellogg 2011 pers. comm.). These were left overnight at 4°C to allow the solution to impregnate the tissue and then stored at -20°C.

Four fragments from three distinct sampling events (n = 12) were split into baskets and subjected to the four shipboard ocean acidification (OA) and temperature challenge experiments (A = 380 ppm, 9°C; B = 380 ppm 12 °C; C = 750 ppm 9°C; D = 750 ppm 12°C).

One polyp from fragments collected during each sampling event was collected and preserved for genotyping as described previously. One fragment from each sampling event was immediately preserved in RNALater to characterize *Lophelia's in situ* transcriptome. The coral fragments were then allowed to acclimatize for six days in aquaria kept at ambient partial pressure of CO₂ and 9°C. On May 25, 2012, all fragments were distributed to the four respective treatment tanks. Prior to being placed in these aquaria, a second round of fragments from each sampling event were preserved in RNALater to establish "Time 0" and quantify any changes to the transcribing genome after the acclimatization period. All fragments were kept in their respective aquaria until June 14, 2012 (i.e., 21 days). Fragments were subsequently removed and preserved in RNALater for further analyses of the *Lophelia* transcriptome.

f. Analysis of the *Lophelia*-associated microbiome: Remaining live *Lophelia* polyps were placed into 50 ml falcon tubes and immediately stored at -80°C. If samples contained a mixture dead and live *Lophelia* or other organisms (e.g. stylasterids, worms, brittle stars, bivalves, anemones) these were carefully removed and also preserved separately in plastic tubes at -80°C.

6.5.2 Results and initial conclusions

All samples will require further processing before results are available. We have no reason to believe the samples were compromised or contaminated in any way either during *in situ* collections or initial processing. Further, the preservation methods we employed have been extensively used and published in relevant literature. As such, we have every reason to believe that the material destined for all culture-independent analyses will reflect the *in situ* environment.

6.5.3 Future analyses

Coral genotyping: The FTA cards containing preserved coral DNA will be used to genotype one polyp from each of the three samples from each *L. pertusa* colony. DNA will be extracted from the cards and a subset of microsatellite loci will be amplified as described in Morrison *et al.* (2008).

Bacterial community analysis: Coral polyps stored at -80°C will be thawed and crushed. DNA will be extracted from the resulting slurry using techniques previously used in other studies of *L. pertusa* microbial communities (Kellogg pers. comm.). The bacterial community of the resulting DNA extracts will be characterized using next generation sequencing, targeting 16S rRNA genes. The exact platform used for this will depend upon the availability of resources but is likely to be either achieved using either the Roche GS FLX sequencer (454 Life Sciences) or an Illumina MiSeq.

Sequence results will be compared to nucleotide entries in the NCBI database and subjected to phylogenetic analysis to determine identity.

Functional gene analysis: The presence, diversity and abundance of nitrogen cycling functional guilds associated with the *Lophelia* samples will be described and quantified by amplification of functional genes from the DNA extracts. The exact processes and genes to be targeted remain to be chosen but are likely to include the following: nitrification (amoA genes), denitrification: (nirS, nosZ and nirK) and anammox (hzoA and anammox-bacteria-specific 16S rRNA genes).

FISH analysis: Using the next generation sequence data, bacterial strains of particular interest will be selected on the basis of their abundance or putative identities. FISH probes will be designed which hybridize to these sequences. These will then be applied to the polyps fixed for FISH analysis to determine the exact location of bacteria within the coral tissue.

6.6 Sponge ecophysiology and trophic ecology (Georgios Kazanidis & John Polanski)

Recent investigations of cold-water coral reefs in the northeastern Atlantic Ocean and Mediterranean Sea have revealed the presence of a diverse sponge community (Phylum Porifera) (e.g. Longo *et al.* 2005; van Soest *et al.* 2007). The extensive presence of this type of organism (mainly filter feeders) is considered to play an important role in various ecological aspects within the reef systems (van Soest and Lavaleye 2005; van Oevelen *et al.* 2009). Firstly, sponge morphology supports the establishment of both infaunal (e.g. polychaetes) and epifaunal organisms (e.g. ophiuroids, bryozoans) enhancing overall reef biodiversity (Klitgaard 1995; Buhl-Mortensen *et al.* 2010). In addition, although quantitative studies are almost absent, sponges are regarded as having a major role in carbon cycling pathways within the reef ecosystem (van Oevelen *et al.* 2009). Studies from non-cold-water coral regions have revealed that deep-sea sponges (e.g. the hexactinellid *Aphrocallistes vastus*) are able to process large volumes of seawater extracting organic particles with high efficiency (Pile & Young 2006; Yahel *et al.* 2007). Furthermore, the role of sponges in cold-water coral food web has gained additional importance since recent findings revealed the (supplementary to particulate organic carbon) assimilation of dissolved organic carbon (DOC) from species bearing symbiotic microorganisms (e.g. the demosponge *Higginsia thielei*, van Duyl *et al.* 2008).

In the cold-water coral reefs of Mingulay Reef Complex and Rockall Bank, surveys have revealed the existence of more than 100 sponge species (van Soest *et al.* 2007; Roberts *et al.* 2009a) (Fig. 6.2.5). Despite their abundance, basic aspects of sponges' biology— i.e. trophodynamics, respiration - is not well understood (van Duyl *et al.* 2008; van Oevelen *et al.* 2009). This situation hinders our understanding around the role of these organisms in CWRs and especially in the structure and functionality of the food web. Taking into account this paucity of information, the present study focuses on the contribution of sponges to C cycling as well as their role in the food web in the Northeast Atlantic Ocean.



Figure 6.25 Erect and encrusting sponges colonising a large glacial dropstone photographed during JC073 surveys of the Logachev Mounds province at 870 m depth. Note the prominent, feathery organism is an antipatharian coral (probably *Leiopathes*).

6.6.1 Methods

On board “pulse-chase” experiments with labelled substrates: Specimens of an unidentified demosponge (Figure 6.26) were collected on the Logachev Mounds (55.49423°N, 15. 8221°W) with the ROV “Holland 1” between depths 747-810 m in May 2012. All the individuals were found to be attached to dead fragments of the scleractinian corals *Madrepora oculata* and *Lophelia pertusa* as well as on unidentified hydrocorals (Stylasteridae). Following recovery on deck, sponge specimens were placed on a holding tank for overnight acclimation at 9°C.



Figure 6.26 Demosponge specimen on dead coral fragments.

Preparation of labelled substrates: In this study four labelled substrates were used: glucose (^{13}C), ammonium (in the form of $^{15}\text{NH}_4\text{Cl}$), *Thalassiosira rotula* microalgae and bacteria (both double-labelled with ^{13}C and ^{15}N). Ammonium was added to a concentration of 0.2 μM while other substrates were added to a concentration of 100 μM (Kiriakoulakis *et al.* 2007; van Duyl *et al.* 2008).

Incubation experiments: Sponges of similar size attached to dead coral fragments were placed into 6 L incubation chambers filled with GF/F filtered seawater. Chambers were made from transparent polycarbonate tubes with acetal plastic lids, each equipped with a stirrer and an optode (AANDERAA 3930), see Figure 6.27. Oxygen concentration and temperature values were recorded every 5 min. In all experiments, the final oxygen concentration did not drop below 70% of the initial concentration. For each treatment (i.e. type of substrate) three replicates and one control (i.e. chamber without a sponge) were used. Incubations were conducted in the ship’s CT room in darkness at 9°C for a time period of 24 h.

In order to quantify respiration of the added substrates, water samples (5 ml) were taken for DI^{13}C analysis. Samples were taken after the addition of the labelled substrates ($t=0$) and at the end of the experiment ($t=24$). Sampled water was replaced with GF/F filtered seawater. The water samples taken for DI^{13}C analysis were filtered through a 0.2 μm syringe filter and stored in 3.6 ml exetainers. Saturated HgCl_2 was added (0.2% v/v) in order to stop bacterial activity. Storage took place in 4°C until further analysis. At the end of incubation the total wet weight of the sponges was measured (± 0.01 g). Tissue was collected in food freezer bags and stored in -20°C until further processing.

Abundance of prokaryotes in sponge tissue: Samples of sponge tissue were preserved according to van Duyl *et al.* (2008) to investigate the potential presence and abundance of bacterial symbionts. Treatment included: (i) fixation of samples in a 1:1 (v/v) phosphate buffered saline (PBS) and

paraformaldehyde solution for a period <12 h at 4°C, (ii) washing of samples twice with 1xPBS, and (iii) storage at -20°C with PBS:ethanol (1:1 v/v).

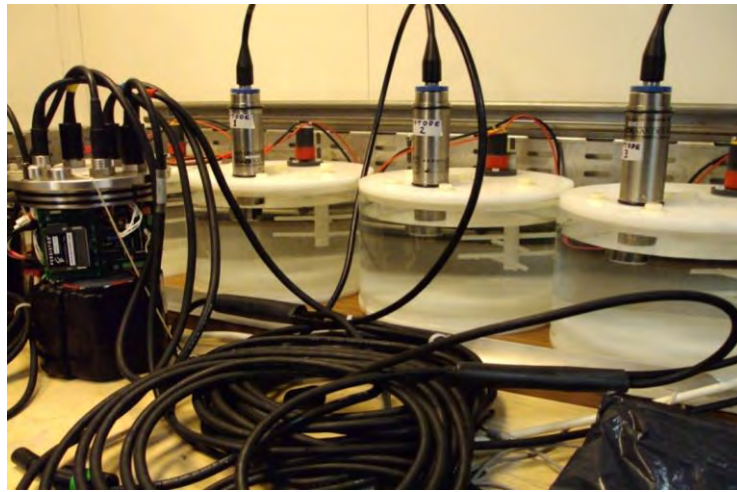

Figure 6.27 Incubation chambers.

Trophic relationships between sponge's epifaunal groups: Specimens of an unidentified demosponge (Fig. 6.28) were collected on the Mingulay Reef Complex (56.82316°N, 7.39491°W) and Logachev Mounds (55.49423°N, 15. 8221°W) with the ROV *Holland-1* in May 2012. At Mingulay, collection took place between 123-128 m depth while at the Logachev Mounds depths were between 747-810 m. Individuals were attached to dead fragments of various cold-water corals (*L. pertusa*, *M. oculata*, *Stylaster* sp.) and were colonised by a diverse epifaunal community. All the “assemblages” (i.e. sponge and associated fauna) were fixed in 10% formalin for future processing.



Figure 6.28 Demosponge attached to dead coral fragments. This sponge is colonised by a diverse epifaunal community including ophiuroids, zooanthids and annelids.

6.6.2 Results and initial conclusions

On board “pulse-chase experiments”: The assimilation of the various substrates as well as DI^{13}C values will be examined using relevant techniques in the laboratory (Moodley *et al.* 2000).

Respiration: Oxygen consumption values will be available after assessment of sponge dry mass and ash-free dry mass to allow data normalisation (Gatti *et al.* 2002).

Sponge epifauna taxonomic identification: Preliminary observations on the sponge’s epifauna revealed the presence of the following taxa:

Phylum Cnidaria

- Class Hydrozoa
- Class Anthozoa

Phylum Annelida

- Class Polychaeta

Phylum Mollusca

- Class Gastropoda
- Class Bivalvia

Phylum Echinodermata

- Class Ophiuroidea

Phylum Bryozoa

- Class Gymnolaemata

Phylum Hemichordata

- Class Ascidiacea

6.6.3 Future analysis planned

Pulse-chase experiments with labelled substrates:

- Drying of sponge material, homogenisation, dry weight/carbon and nitrogen content determination
- Measurements of DI^{13}C , $\delta^{13}\text{C}$ and $\delta^{15}\text{N}$ of sponge tissue (Moodley *et al.* 2000)
- Extraction and preparation of fatty acid methyl esters (Masood *et al.* 2005)

Abundance of bacterial symbionts:

- Dissociation of sponge cells and harvesting of bacteria (van Duyl *et al.* 2008)

Trophic relationships between sponge’s epifaunal groups:

- Determination of ^{13}C and ^{15}N isotopic signatures of each epifaunal group

6.7 Aquatic eddy correlation measurement of *in situ* benthic oxygen flux (Karl Attard)

The benthic O₂ exchange rate is the most widely applied measure of integrated biological activity at the seabed, encompassing primary production, faunal and microbial respiration rates as well as the chemical oxidation of reduced products of anaerobic decay processes. With the addition of the Aquatic Eddy-Correlation (AEC) lander system, the benthic O₂ exchange rate can now also be resolved in complex and hard benthic substrates, although to date very few studies in these environments exist. The AEC lander system offers an opportunity to investigate habitats such as cold-water coral reefs and may provide valuable *in situ* information on large-scale (m²) reef community O₂ consumption rates.

The AEC lander is an autonomous system capable of resolving areal-averaged O₂ fluxes under true *in situ* conditions with a temporal resolution on the order of minutes. The system measures high-frequency (up to 64Hz) 3-dimensional current velocity and O₂ concentrations and integrates a large area of the seabed between 50-100 m². Being completely non-invasive it can be used in regions with fine or coarse sediments, and in areas dominated by macroalgae or macrofauna. The AEC technique is currently capable of resolving fluxes for dissolved oxygen, temperature, conductivity, nitrate and hydrogen sulphide.

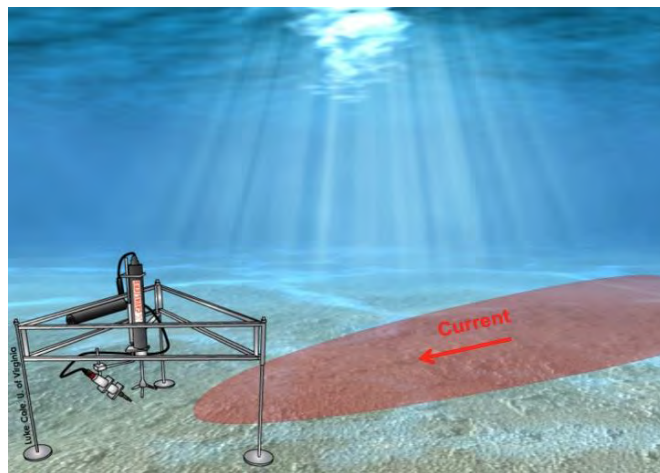

Figure 6.29 The aquatic O₂ eddy-correlation system measures the benthic O₂ exchange rate without affecting the natural hydrodynamics and, if applicable, light conditions on the seabed.

The main components of the AEC lander system comprise an Acoustic Doppler Velocimeter (ADV, Nortek AS, Norway) and Clark-type O₂ microelectrodes (University of Southern Denmark) connected to a picoamplifier (GEOMAR/Univ. S. Denmark). For redundancy purposes, the AEC system used during JC073 was configured with two sets of amplifiers and electrodes. Each amplifier was connected to one of the ADV's two analogue ports and powered by an external battery canister. Apart from logging velocity data, the ADV simultaneously logs the O₂ data from the electrodes. The configuration of the AEC lander used on JC073 allowed for almost 3 days of continuous data recording at 64 Hz, limited by the ADV's 361 MB internal memory capacity.

These instruments were mounted on a specially-constructed stainless-steel tripod frame with the ADV aligned perpendicularly to the seabed (Fig. 6.30) and the picoamplifier/electrode system positioned in such a way that the tip of the microelectrode was 5-10 mm from the edge of the ADV measuring volume (Fig. 6.31).

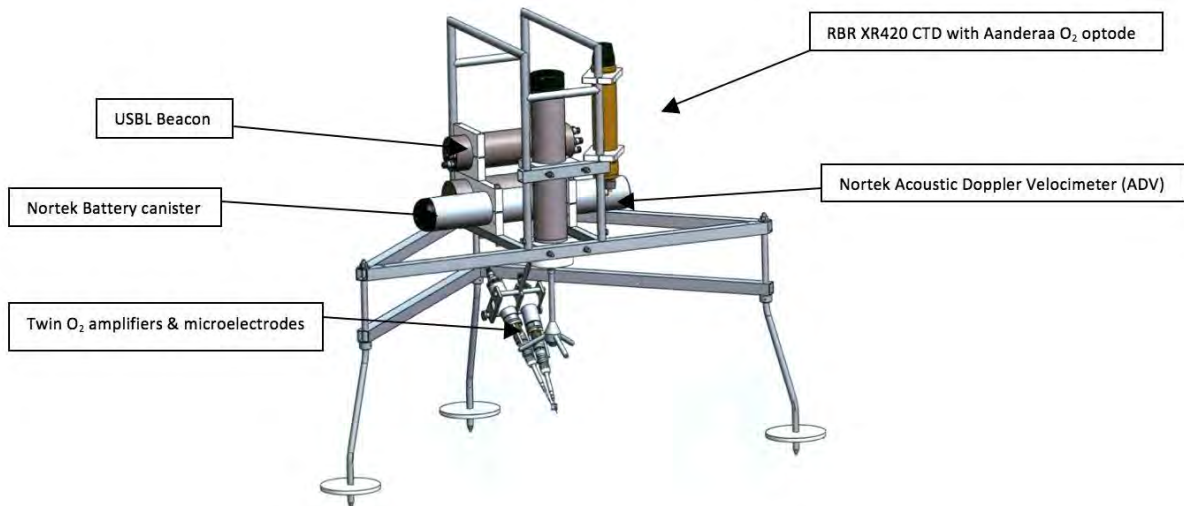

Figure 6.30 The AEC setup used during JC073 (image courtesy R. Schwartz, GEOMAR)

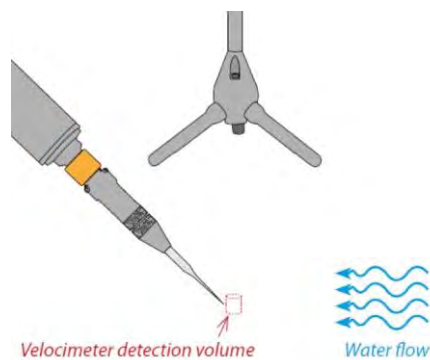

Figure 6.31 The microelectrode tip was positioned about 1 cm from the 1.5 cm x 1.5 cm cylindrical measuring volume located 14.9 cm below the centre of the ADV centre sensor.

Since the JC073 AEC lander system was to be deployed by ROV, a new frame (modified slightly from the original design by GEOMAR/Univ. S. Denmark) was fabricated for this purpose in consultation with the ROV team. Furthermore a triangular mounting frame was constructed to keep the AEC lander legs firmly on the ROV's extendable front apron during deployment and recovery (Fig. 6.32).



Figure 6.32 The JC073 AEC lander system mounted onto the *Holland-1* ROV ready for deployment.

6.7.1 Methods

The JC073 AEC lander system was powered by six Nortek 12V 5Ah Li-ion rechargeable batteries. Two of these were wired in parallel and placed inside the ADV housing to power the ADV, whilst the other four batteries, also wired in parallel, were placed inside the external battery canister to power the picoamplifiers.

Clark-type oxygen microelectrodes measure dissolved oxygen (DO) based on an electrical current generated by the oxidation of DO on the cathode of the microelectrode. The current produced (in picoamps) has a linear relationship with the dissolved oxygen partial pressure in the water. This signal is amplified to arbitrary units (counts) and in order to convert this to DO concentration, a two-point calibration was carried out using a sodium dithionite solution for the 0% DO saturation value prior to deployment and the CTD O₂ optode for the *in situ* DO concentration after the lander was recovered. *In situ* DO values were confirmed by comparing the optode values to those obtained from regular profiles carried out by the ship CTD as well as Winkler titrations from recovered bottom water samples (see Section 5.2.4).

Microelectrodes used during JC073 were pressure compensated, and were fitted with guard cathodes that oxidize diffused oxygen present in the electrolyte behind the measuring cathode. Before deployment the microelectrodes were polarized at -0.8V overnight to ensure there was no drift in the signal as a result of residual DO in the electrolyte. The microelectrode terminals were housed within a pressure-compensated watertight acrylic housing filled with paraffin oil (GEOMAR/Univ. S. Denmark), and connected to the picoamplifier via a 3-pin glass-sealed Kemtite connector (Kemlon, USA), see Fig. 6.33.



Figure 6.33 The acrylic pressure-compensated microelectrode housings used during JC073

The ADV was programmed to record data continuously at 64Hz. The nominal velocity range was set to +/- 0.3 m/s (corresponding to a horizontal velocity range of 0.81 m/s and a vertical velocity range of 0.23 m/s). The full deployment details from the ADV .HDR file are as follows:

Serial number	VEC 6365
Internal code version	0
Revision number	4
Recorder size	361 MByte
Firmware version	3.33
Power output	12V
Sampling rate	64 Hz
Nominal velocity range	0.30 m/s
Burst interval	CONTINUOUS
Samples per burst	N/A
Sampling volume	14.9 mm
Measurement load	59 %
Transmit length	4.0 mm
Receive length	0.01 m
Output sync	VECTOR
Analog output	DISABLED
Analog input 1	FAST
Analog input 2	FAST
Power output	DISABLED
Output format	VECTOR
Velocity scaling	0.1 mm
Power level	HIGH
Coordinate system	XYZ
Sound speed	MEASURED
Salinity	35.0 ppt
Distance between pings	1.01 m
Number of beams	3
Software version	1.32

The RBR XR420 CTD mounted onto the AEC lander frame was programmed to sample conductivity, temperature, depth and DO every 60 seconds.

Site selection: Since well-developed turbulence is required for correct AEC flux measurements, care was taken to deploy the lander system away from any large coral mounds or boulders. Before deployment the area was surveyed by ROV and once a suitable spot was found, the lander was deployed by the ROV onto the seabed. The study site locations and deployment statistics are outlined in Table 6.12. The first station, JC073 Station 038 at Mingulay Reef was characterized by live coral colonies forming small seabed mounds separated by flat regions of relict coral fragments and fine sediments (Fig. 6.34). The second lander deployment (JC073 Station 062) was on top of a mound within the Logachev complex, consisting of uneven relict coral framework with sporadic patches of live coral colonies, anemones and sponges (Fig. 6.35). The third deployment (JC073 Station 099) was approx. 300 metres off mound and was characterized by an even seabed topography consisting of small relict coral fragments and sediments (Fig. 6.36).

Table 6.12 AEC lander deployment locations and statistics

Lander Deployment No.	JC073 Station No.	Latitude N	Longitude W	Depth (m)	Deployment duration (hr)	AEC dataset length (hr)
1	038	56 49.354	7 23.723	138	21	20
2	062	55 33.576	15 39.315	565	23	21
3	099	55 33.197	15 39.182	830	64	9*

*Dataset cut short due to sensor breakage

The data processing protocol was for the large part consistent with the steps outlined by Lorrai *et al.* (2010). The processing was executed in the following order:

1. The 64Hz ADV dataset was averaged down to 8Hz, and outliers were replaced by interpolation using a constant threshold rate of change for flow (defined as an acceleration in the vertical velocity) and concentration data relative to a moving average.
2. The measured current velocities were then rotated into streamline coordinates using the 'planar fit' method (Wilczac *et al.*, 2001; Lorke *et al.*, submitted).
3. The dataset was then corrected for any offsets resulting from the sensor position or response time relative to the flow data. This was done using a cross-correlation function in Origin 8.5, normalizing the output, and shifting the O₂ data relative to the velocity data for the maximum correlation statistic.
4. Cospectral analysis of the O₂ and velocity data was carried out to define the frequency range for the flux-contributing eddies.

O₂ areal fluxes, in mmol O₂/m²/day were then derived from the 8Hz dataset using a flux window corresponding to the upper limit of the flux-contributing eddies.

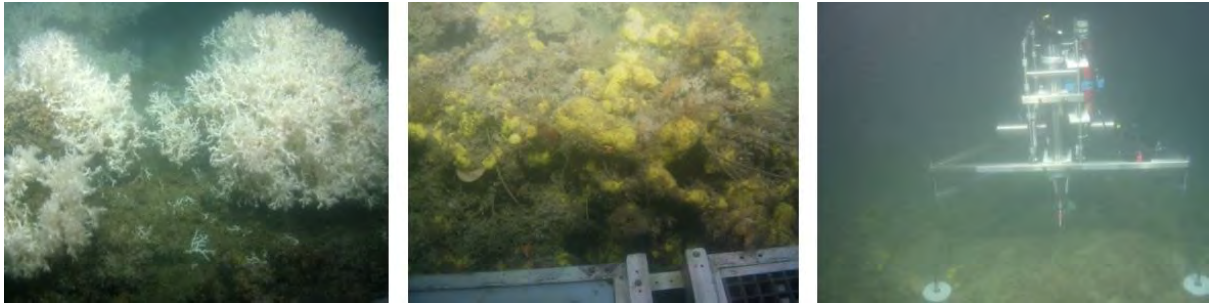

Figure 6.34 Deployment 1 at Mingulay Reef showing *Lophelia* coral colonies (left) sponges (centre) and the AEC lander deployed (right) at Mingulay Reef

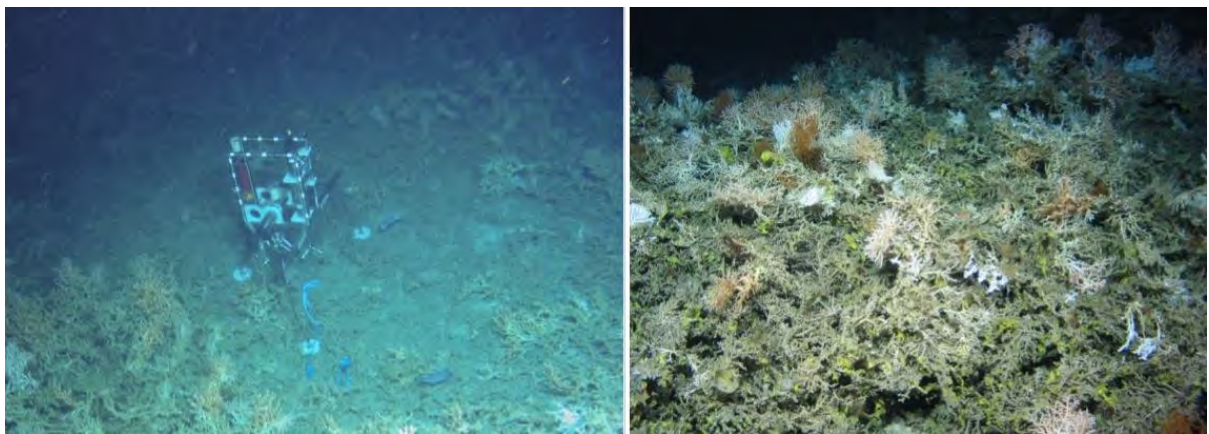

Figure 6.35 Deployment 2 at Logachev mounds showing the AEC lander deployed (left) and the coral ecosystem within the lander footprint (right).

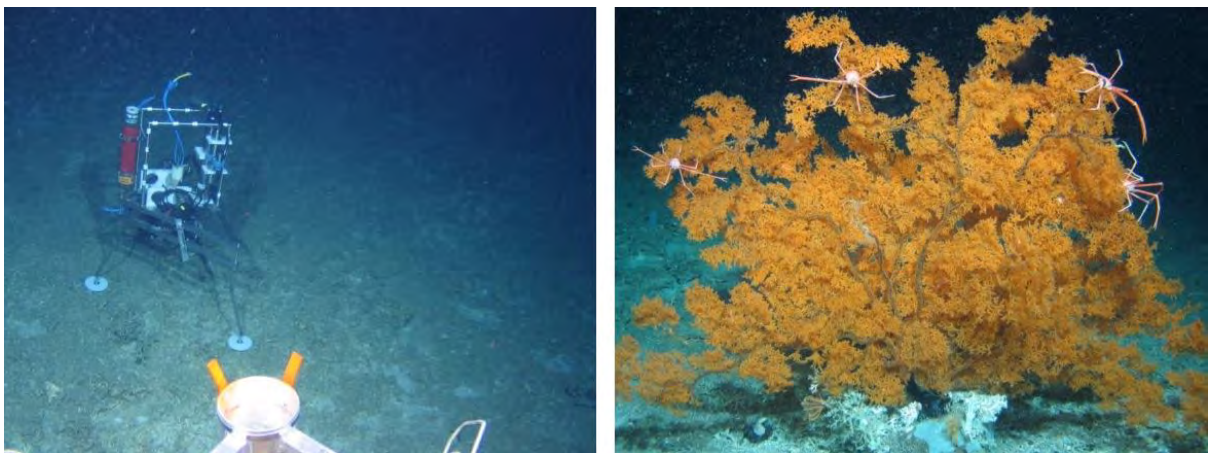

Figure 6.36 Deployment 3 at the base of Logachev mounds showing (left) the AEC lander deployed and (right) a large black coral present within the footprint area.

6.7.2 Results

Only data from Mingulay Reef (JC073 Station 038) are presented in this report. The other two datasets require further processing. The results from this deployment are summarized in Fig. 6.37. The average flux for the whole dataset was $-23.7 \text{ mmol/m}^2/\text{d}$ (± 14.6). The flow field was predominantly tidally-driven, having a periodicity of around 6 hours (Fig. 6.37, 6.38). Fluxes derived from the two prevalent directions ($310^\circ\text{-}320^\circ$ and $130^\circ\text{-}140^\circ$) constituted 93% of the dataset. Fluxes from Direction A ($310^\circ\text{-}320^\circ$) averaged $-22.2 \text{ mmol/m}^2/\text{d}$ (± 13.8 , $n=562$) and those from Direction B ($130^\circ\text{-}140^\circ$) $-26.6 \text{ mmol/m}^2/\text{d}$ (± 12.1 , $n=482$). Coral mounds were present 3-6 m away from the instrument in both directions. A strong relationship between the current velocity and the O_2 flux rate could be observed for the entire dataset (Fig. 6.39, 6.40).

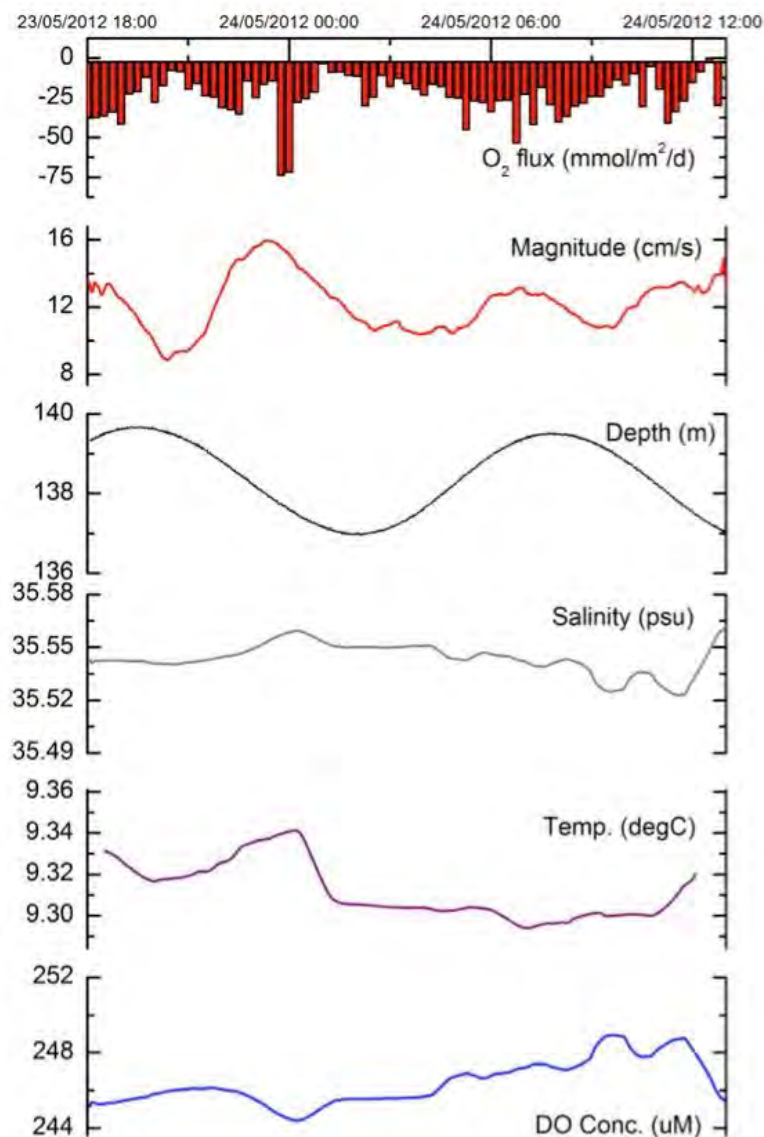

Figure 6.37 Summary of the deployment at Mingulay Reef. The O_2 flux data is presented in 15 minute bins.

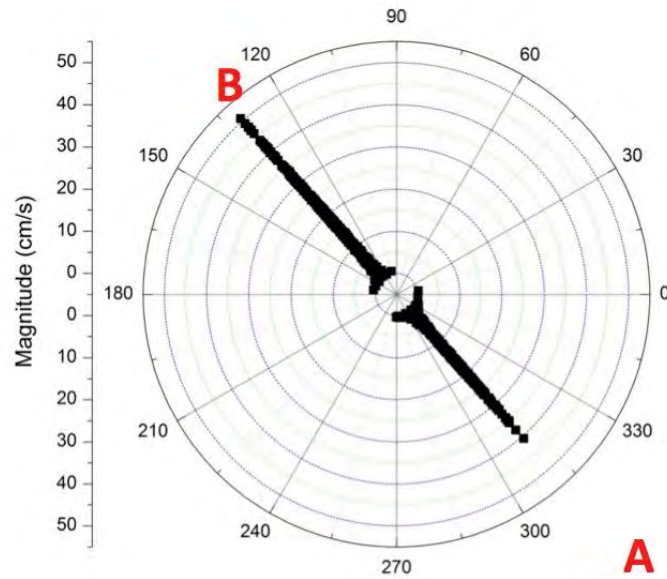

Figure 6.38 Directional flow and magnitude during the Mingulay Reef deployment. Zero degrees is the instrument's North. Fluxes derived from Direction A (310°-320°) constituted 50% of the full dataset, and those from Direction B (130°-140°) constituted 43%. Coral mounds were present 3 to 6 metres away from the instrument in both direction A and B.

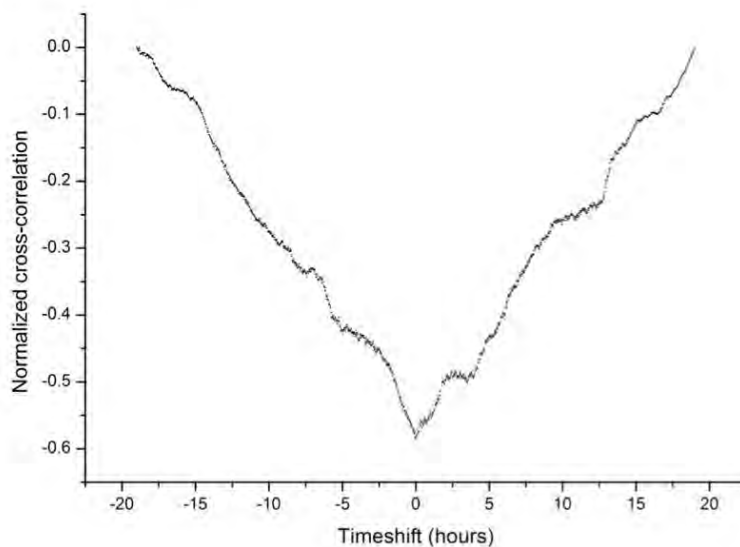

Figure 6.39 A 'cross-correlation' analysis of current velocity and the O₂ flux rate over the entire dataset, indicating that the current velocity and the O₂ flux rate are in sync with one another. This suggests that the tidally-driven flow is driving the O₂ exchange rate at Mingulay Reef.

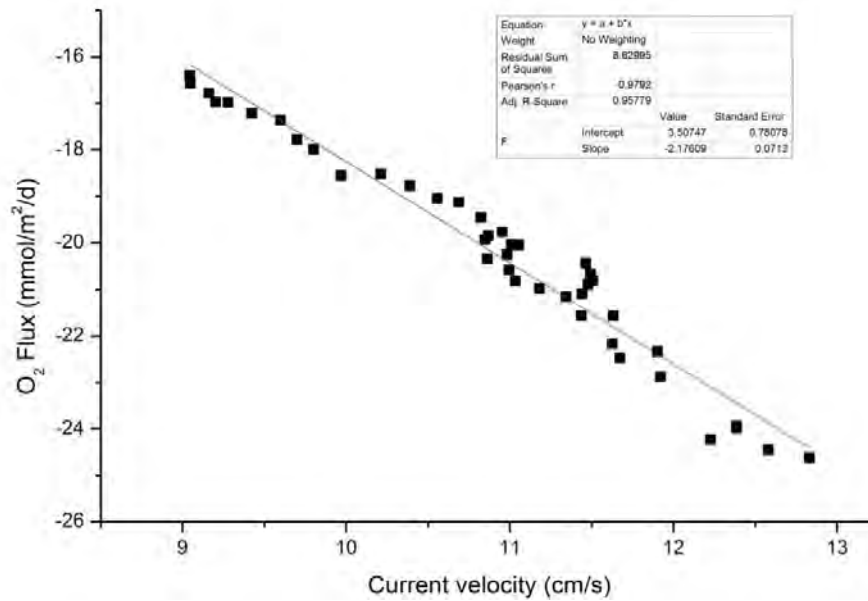

Figure 6.40 A period isolated from the Mingulay Reef dataset indicates that the O₂ uptake rate increases by 1.5 times following an increase in current velocity from 9 to 13 cm/s.

6.7.3 Initial conclusions and further analysis planned

The initial results from the JC073 AEC lander deployments look promising and suggest a dynamic environment characterized by highly intermittent O₂ uptake rates by the reef community. The analyses indicate that the tidally-driven flow is a crucial component of this ecosystem, potentially acting as a nutrient supply and waste product removal mechanism for the reef community to be able to sustain itself.

Further processing of the other two datasets will reveal whether this feature is also present at these sites, and how the flux rates compare between these ecosystems. Future analysis will be directed towards better describing the flux-contributing 'footprint' through ROV video analysis of the sediments and infauna using images obtained from the Sediment Profile Imaging (SPI) system used during JC073. We will also draw comparisons between the AEC O₂ fluxes and *Lophelia* respiration rates carried out onboard the ship.

Altogether, the success of this expedition will serve as an important validation for the application of the AEC technique in a hydrodynamically-complex setting.

6.8 Oxygen microgradients in *Lophelia pertusa* polyps (Karl Attard)

Oxygen microprofiling was carried out on coral polyps of *Lophelia pertusa* to investigate the oxygen gradients at the polyp-water interface. Microprofiling was carried out using a Clark-type electrode with an internal reference and a guard cathode (Revsbech, 1989). The diameter of the electrode tip was 10 – 20 μm with a stirring sensitivity of less than 1% and a response time of less than 0.5 seconds. The electrode was mounted onto a computer-driven motorized micromanipulator and the sensor signal was transferred to the computer via a picoammeter connected to an analog-to-digital convertor (Revsbech & Jørgensen, 1986; Fig. 6.41). The microsensor signal was converted to oxygen concentration ($\mu\text{mol l}^{-1}$) using a two-point calibration. The oxygen concentration in the water column was set as the 100% air saturation reference whilst the 0% saturation value was obtained using a sodium dithionite solution.

Coral fragments recovered by ROV were glued onto a stage and placed into an incubation chamber. The water in the chamber was kept aerated by an air pump, and a rotating magnet located above the polyp kept the waters well mixed. Profiling was carried out in 50 or 100 μm intervals into the tentacles and septa.

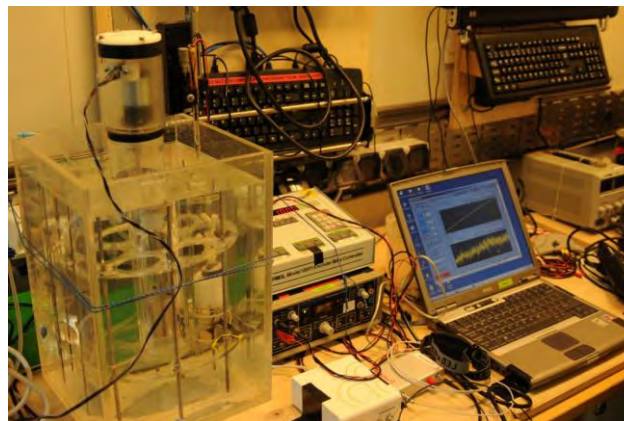

Figure 6.41 Microprofiling setup used in JC073 showing the incubation chamber and *Lophelia* fragments (left) and the computer setup (right).

Oxygen gradients at the polyp-water interface were consistently detected and the rate of oxygen uptake derived from these gradients was around $20 \text{ mmol m}^{-2} \text{ d}^{-1}$ (Fig. 6.42).

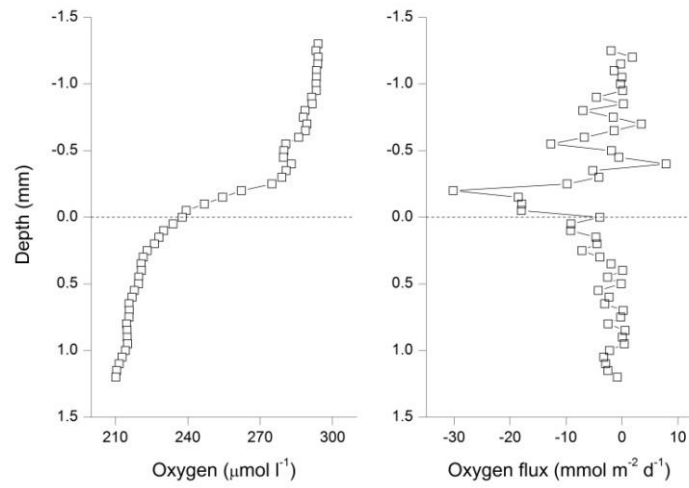

Figure 6.42 Oxygen microgradients in polyp tissue (left) and derived oxygen flux (right). The broken line at depth 0.0 represents the location of the polyp tissue surface. Negative depths correspond to measurements carried out above the polyp tissue, and positive depths correspond to measurements within the polyp tissue.

6.9 Sediment Profile Imagery (SPI) survey (Silvana Birchenough and Nigel Lyman)

Ocean acidification (OA) is predicted to reduce mean ocean pH by 0.3-0.5 by 2100, and 0.7 by 2300 (Pascal et al. 2010), equating to a reduction in OH^- and CO_3^{2-} ions in surface water by 82 and 77% respectively (Millero et al. 2009). In addition to effects of OA on calcification in marine invertebrates, there are also potential implications for the cold-water coral habitats. It is important to understand the biodiversity status of these habitats for understanding future changes that might affect and/or modify these areas.

Cefas used a Sediment Profile Imaging camera (SPI) and a video camera to characterise the diversity of a range of habitat types at the Mingulay reef complex and within the Logachev coral carbonate mounds at Rockall Bank. The SPI images helped to study *in situ* habitat types. A series of vertical images showing infaunal presence/absence and biogenic structures (e.g. burrows, feeding voids, redox layer and sediment types) in the habitats adjacent to the *Lophelia pertusa* reefs were collected. By recording some of these parameters we can understand the existing biodiversity and function (e.g. bioturbation and bioirrigation) of the communities adjacent to the cold-water coral reefs.

Alongside the SPI work, a parallel collaboration was planned with the University of Southampton (Dr Martin Solan and Dr Claudia Alt). The idea was to collect and incubate sediment corers with fauna for assessing bioturbation in the areas where the SPI transects were collected. Additionally, biochemical oxygen measurements were also planned with incubated corers (collaboration with Karl Attard University of Southern Denmark). Cefas also planned the use of Diffusive Gradients in Thin-films (DGTs) to monitor labile metals in the sediment profiles containing the fauna and sediment incubations. The DGTs were de-oxygenated in prior in a 0.01M NaCl solution and bubbled continuously with oxygen-free nitrogen gas. The DGT information would have been complementary to the colour change observed in the SPI images. The overall work was planned to 'scale-up' small scale experiments and provide experimental results with a wider interpretation. Unfortunately, after several attempts to collect sediments, the box corer failed to provide successful samples. This was mainly due to the nature of the seabed which was a combination of soft sediments and underlying rocky patches.

6.9.1 Methods

The SPI camera survey was conducted in May-June 2012 on board of the RRS *James Cook*. A total of four transects were spaced along the periphery and the immediate vicinity of the *Lophelia pertusa* reef areas (see Fig. 6.43). A series of transects with SPI and a video camera were used to characterise the habitats present in the vicinity of the cold-water coral *Lophelia pertusa* habitats and carbonate mounds site. The areas sampled were the Mingulay reef complex, Banana reef area and Logachev carbonate mounds. A total of 3-5 transects (approximately 1.5 km) were subdivided into 300 m intervals at each study area. At each point of these transects a total of 5 replicates dips were collected.

Area	Transect	Latitude	Longitude	
Mingulay Reef Complex	SPI A (start position)	56	50.2372 -7 24.0097	
	SPI A (end position)	56	50.2277 -7 23.2718	
	SPI B (start position)	56	49.7049 -7 23.2087	
	SPI B (end position)	56	49.6943 -7 22.3961	
	SPI C (start position)	56	49.7097 -7 23.3221	
	SPI C (end position)	56	48.9432 -7 23.7074	
	SPI D (start position)	56	49.6882 -7 24.0353	
	SPI D (end position)	56	49.1275 -7 24.0472	
	SPI E (start position)	56	49.0964 -7 24.2401	
	SPI E (end position)	56	49.0894 -7 23.695	
Banana Reef	BR1 (start position)	56	48.387 -7 26.774	
	BR1 (end position)	56	48.063 -7 26.755	
	BR2 (start position)	56	48.413 -7 26.766	
	BR2 (end position)	56	48.204 -7 26.317	
	BR3 (start position)	56	48.527 -7 26.321	
	BR3 (end position)	56	48.257 -7 26.068	
	BR4 (start position)	56	48.048 -7 26.721	
	BR4 (end position)	56	48.104 -7 26.387	
Logachev mounds (1st survey)	LG1 (start position)	55	33.6578 -15 40.0388	
	LG1 (end position)	55	33.7085 -15 38.4965	
Logachev mounds (2nd survey)	LG2 (start position)	55	33.2294 -15 39.9716	
	LG2 (end position)	55	33.2195 -15 38.6533	
	LG3 (start position)	55	36.1423 -15 40.7288	
	LG3 (end position)	55	33.3519 -15 40.0785	
	LG4 (start position)	55	33.754 -15 36.979	
	LG4 (end position)	55	33.101 -15 36.51	
	LG5 (start position)	55	33.144 -15 38.12	
	LG5 (end position)	55	33.144 -15 37.331	
	Logachev mounds (3rd survey)	LG6 (start position)	55	28.93854 -15 47.276
		LG6 (end position)	55	29.27364 -15 45.0557
LG7 (start position)		55	28.33773 -15 47.1597	
LG7 (end position)		55	28.52822 -15 45.8949	
LG8 (start position)		55	30.41018 -15 48.6683	
LG8 (end position)		55	28.81775 -15 47.9978	

Figure 6.43 Schematic summarising the start and end positions of each SPI transect completed during JC073.

The SPI images provided undisturbed, *in situ* surface and profile images of the upper ~20 cm of the sediment column. Once the SPI images were collected, the original .NEF images were stored in a media drive (backed up copies). A new set SPI images were saved as .JPEG and cleaned for analysis (e.g. lighting artefacts were removed and the prism penetration was measured based on the scale overlaid in the image at 2 cm intervals). The software used to process some of the SPI images was Adobe Photoshop CS3 version 10.01. From each image, the sediment type, sediment boundary roughness (SBR), apparent redox potential discontinuity (aRPD) depth and the Benthic Habitat Quality index (BHQ), (Nilsson and Rosenberg, 1997; Birchenough *et al.*, 2006) will be calculated on return to the laboratory (see Fig. 6.44).

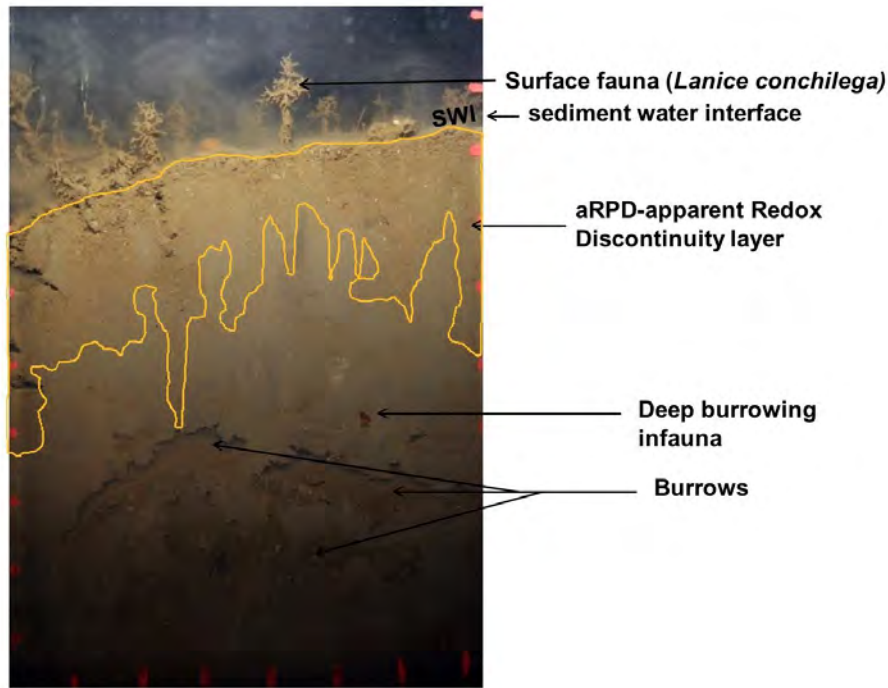

Figure 6.44 SPI image analysis. Note the scales on the image are 2 cm each.

6.9.2 Results and initial conclusions

Over 300 SPI images were collected at the 3 sites. These images will be analysed to characterise the physical and biological status of all the areas. For simplicity, only a sub-set of SPI images are presented in this report (the overall set of SPI images will be analysed and can be available upon request at BODC). The idea of this work is to provide characterisation and information on the aRPD values, biological information and sediment at areas located in the vicinity of the coral areas and adjacent habitat types across different sites.

Mingulay Reef Complex (MRC): The MRC was characterised with an admixture of sediments. These were mainly soft muds outside of the reef (Transects A and C). The initial interpretation of images identified the presence of crinoids (*Leptometra* sp., sponges (*Mycale macilenta*, Kazanidis pers. comm.) and a series of soft corals over stony grounds. The northern area sampled outside of the reef (Transect A) showed the presence of soft sediment areas and with clear indication of deep aRPD (approximately 2 - 4 cm). There were a series of erect polychaete tubes and distinctive burrowing activity in the top layers of sediment (~2 cm). Transect B was not completed as planned due to the lack of time available.

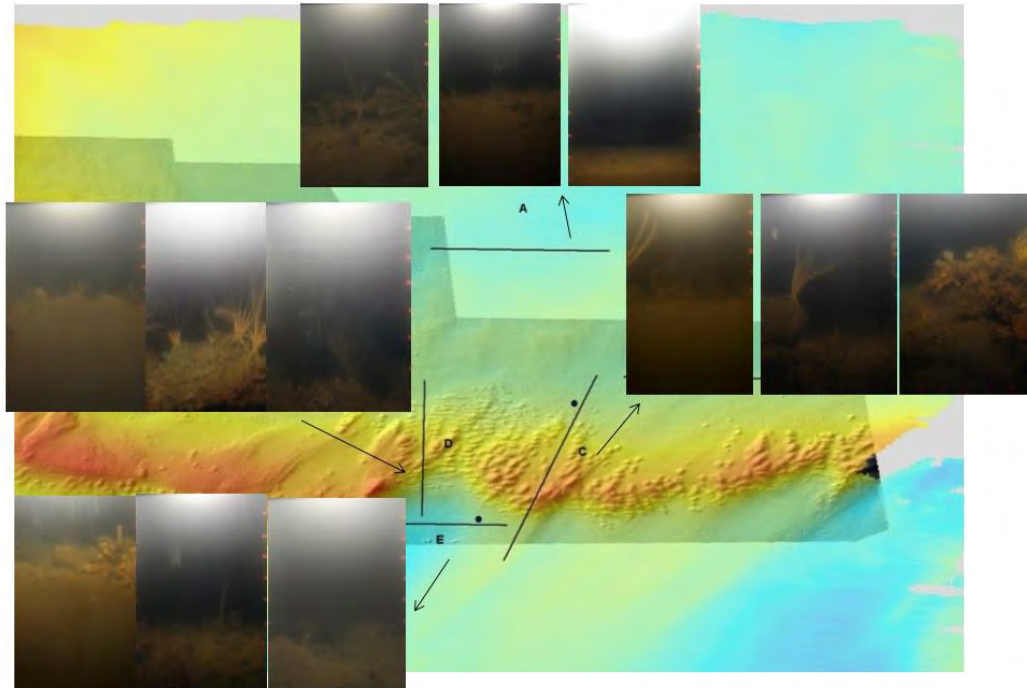

Figure 6.44 SPI images and transects collected at Mingulay reef complex (around Area 01) in May 2012 overlaid over multibeam image.

The Banana Reef (BR) showed a series of well-defined areas around the *Lophelia pertusa* reef. Transect BR1 outside the reef was mainly composed of soft muddy sediments. Transects BR1 and BR4 showed a clear area of erect polychaetes tubes of *Lanice conchilega* (Pallas). Deep burrowing activities (ranging from 6-8 cm) were observed in some images, which corresponds to the crustacean *Nephrops norvegicus* (observed during video footage collected alongside the SPI survey). Moving towards the reef areas, there is a clear underlying layer of muddy sediment, with a series of stony areas. There is clear presence of soft corals and encrusting species (sponges and anemones).

The transect BR4 was conducted in deeper waters (248 m depth). This area showed distinct presence of soft mud. There were also some erect polychaetes observed at the sediment-water interface. There was also a distinct presence of deep burrowing polychaetes (~4-6 cm) and burrows in the images (~6 cm). Transect BR3 was not completed due to the lack of time available at the end of the survey period.

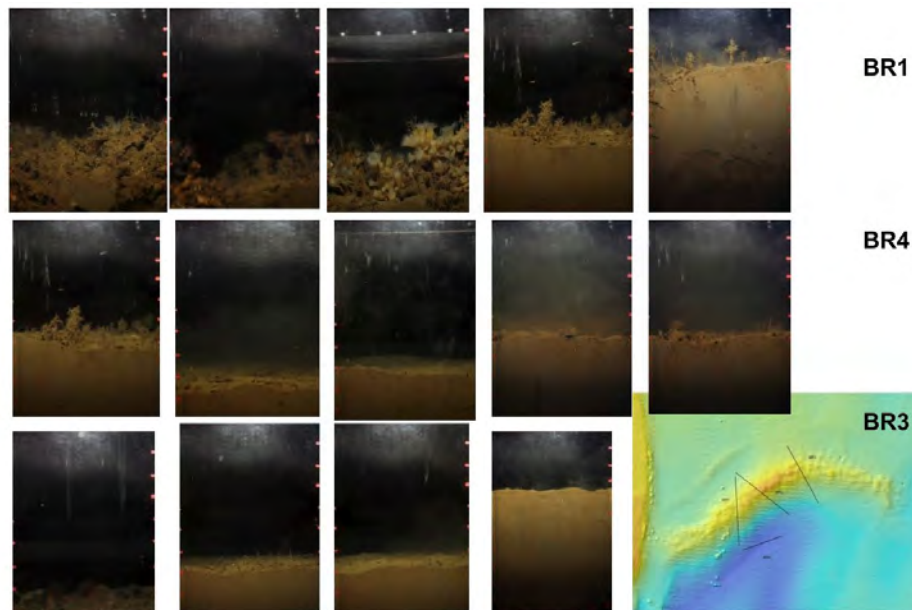

Figure 6.45 SPI images and location of transects collected at Banana Reef during May 2012 overlaid with multibeam image.

Logachev Mounds (LG): Three SPI surveys were completed at Logachev. These were conducted on: (i) 27th May (LG1 and LG2), (ii) 31st May (LG2, LG3 and LG5) and (iii) 5th June (LG6 and LG7). The same transect methodology was consistently applied to allow comparison of transects within and between areas. In many areas coral rubble was observed on the seabed and therefore limited penetrations were obtained with the SPI camera. Nevertheless, the camera managed to capture the presence of coral fragments, layers of coral rubble and attached fauna in its images. There was a distinctive presence of the blue sponge (*Hymedesmia paupertas*) and squat lobsters (*Munida* sp.) amongst the coral fragments. In the video camera observations, there was indication of the coral *Madrepora oculata*, the yellow sponge *Mycale macilenta*, the white sponge *Aphrocallistes bocagei*, cup sponges *Phakellia* sp. and some hydrocorals such as *Pliobothrus symmetricus* and *Stylaster erubescens*.

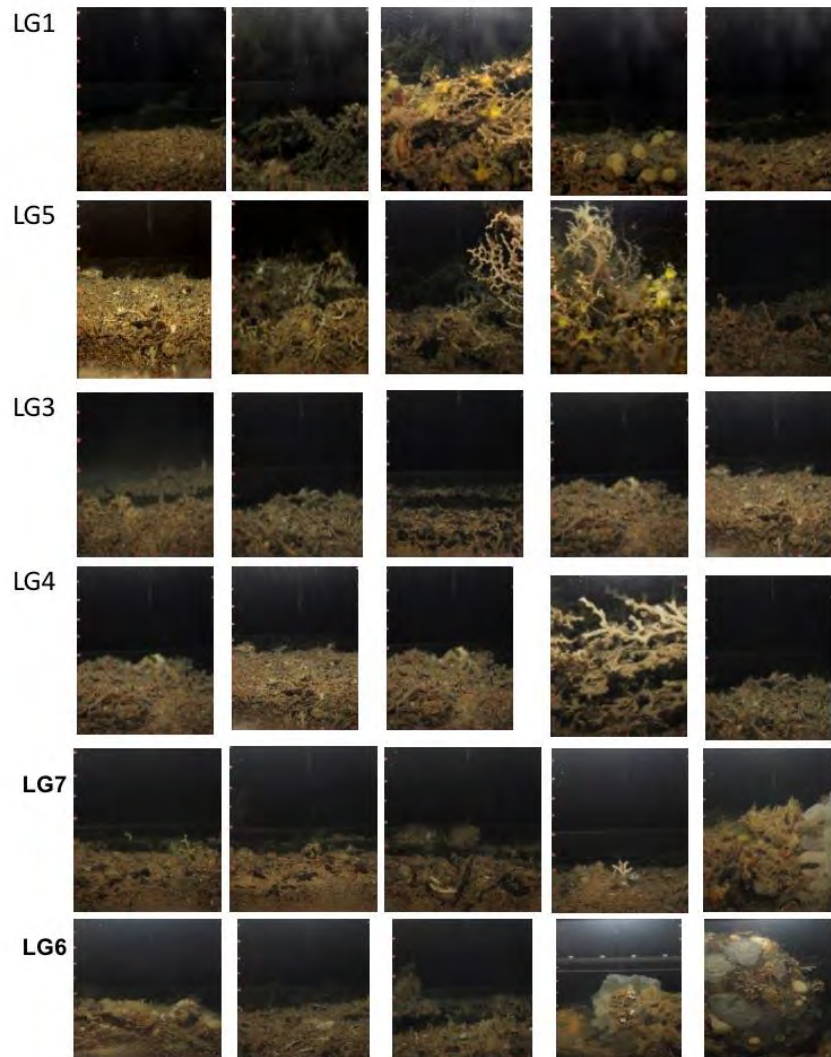

Figure 6.46 SPI images and location of transects collected at Logachev mounds during May and June 2012.

6.9.3 Future analysis and collaborations planned

The results of the SPI survey will be written up as a publication to report on the vertical characterisation of the habitats sampled across sites. Complementary information from the multibeam, MVP and Eddy Correlation Lander surveys will be useful to support the ecological results and further characterisation of these areas.

A further collaboration is planned with Dr Covadonga Orejas at the Instituto Español de Oceanografía, Spain to analyse the video stills images (76 cm x 22 cm) collected from video transects. This information will help with information for calculating percentage coverage of the fauna present in these areas. The plan is to organise a working session at Cefas to analyse these images and complement with the hydrographic data sets available for a wider spatial habitat interpretation.

6.10 Spatial distribution and habitat use by deep-sea fish (Rosanna Milligan)

In the deep waters of the north-east Atlantic, one of the primary reef-framework forming species is the ahermatypic scleractinian coral *Lophelia pertusa*. Skeletons of *L. pertusa* provide hard substrate on which other species can settle and grow, including several species of gorgonian, hydroid, antipatharian and scleractinian coral (Roberts *et al.*, 2006) which in turn provide increased habitat relief and structural complexity for a variety of macro- and megafaunal taxa (e.g. Jensen & Frederiksen, 1992, Roberts *et al.*, 2006). Since the majority of the deep-sea is typically characterised by soft sediments, there is the potential that these 'islands' of hard substrate may be of great importance as centres of biodiversity in deep water.

The importance of *Lophelia* habitat for fish is beginning to be understood, and a number of studies have been conducted in the north-west Atlantic and Gulf of Mexico in particular which suggest that scleractinian reefs may support a distinct fish fauna compared to off-reef areas (e.g. Ross & Quattrini, 2007, Sulak *et al.*, 2008, Quattrini *et al.*, 2012). In the north-east Atlantic, Costello *et al.* (2005) examined video and stills footage from eight locations from Norway to the Porcupine Seabight, but failed to find any significant associations between fish assemblages and habitat type, instead citing depth as the most significant driver of the fish composition. More recently, Soffker *et al.* (2011) examined the habitat associations of fish on giant carbonate mounds on the Porcupine Bank but only found significant associations of fish species at one of the two sites studied. There is therefore still considerable uncertainty regarding the importance of *Lophelia* framework habitats for different fish species, and whether they may provide essential habitat or simply promote facultative associations.

The aims of this study were to collect novel ROV video data from *Lophelia* coral habitats and the surrounding soft sediment from the Mingulay reefs (South Minch), Logachev mounds (Rockall Trough), Pisces 9 site (Rockall Bank) and the Hebrides Terrace Seamount, to assess the distributions and behaviour of the associated deep-water fish assemblages over a range of spatial scales from the large scale (100s of km) to very fine scale (10s of meters).

6.10.1 Methods

ROV transect data were collected using the ROV *Holland-1* (Marine Institute, Galway, ROI) during habitat surveys and periods of travel on the seabed between experimental sampling sites. During each dive a high definition video camera recorded continuous footage and distances were indicated by a pair of lasers. Only footage taken while the ROV was moving with the camera at its widest zoom will be used for quantitative analysis. Suitable footage was collected from 27 of the 41 ROV dives made during the cruise, which were conducted over eight sites across four locations between 19/05/2012 and 13/06/2012, a summary of which is given in Table 6.13.

The ROV video will be formally analysed at the University of Glasgow after the end of the cruise following the protocol established by Costello *et al.* (2005). This methodology allows the analysis of opportunistically-obtained video footage to assess patterns of fish abundance and behaviour across a range of habitats by standardising the data according to the duration of useable footage from each habitat. In this manner, a quantitative comparison of the fish fauna and their behaviours can be

made without requiring the inclusion of a dedicated, randomised video survey to a cruise schedule. A summary species catalogue of the commonest species recorded is given below.

Table 6.13 Summary of ROV dives resulting in useable transect footage.

Dive No.	Date	Location	Site	Duration of Seabed Footage (hh:mm)
1	19 th May 2012	Mingulay	Mingulay 1	3:44
2	20 th May 2012	Mingulay	Mingulay 1	1:37
3	20 th May 2012	Mingulay	Mingulay 1	1:37
4	22 nd May 2012	Mingulay	Mingulay 1	1:33
5	22 nd May 2012	Mingulay	Mingulay 1	6:56
7	23 rd May 2012	Mingulay	Banana Reef	3:49
8	23 rd May 2012	Mingulay	Mingulay 1	2:53
10	23 rd May 2012	Mingulay	Mingulay 1	1:39
40	13 th June 2012	Mingulay	Mingulay 1	6:53
41	13 th June 2012	Mingulay	Mingulay 1	3:22
12	27 th May 2012	Logachev	Logachev 1	2:34
13	27 th May 2012	Logachev	Logachev 1	3:09
15	28 th May 2012	Logachev	Logachev 1	1:33
16	28 th May 2012	Logachev	Logachev 1	3:13
19	30 th May 2012	Logachev	Logachev 2	6:31
20	30 th May 2012	Logachev	Logachev 2	2:27
25	4 th June 2012	Logachev	Logachev 3	3:45
26	4 th June 2012	Logachev	Logachev 3	2:34
28	6 th June 2012	Logachev	Logachev 1	4:11
30	7 th June 2012	Rockall Bank	<i>Pisces</i> 9	1:07
31	7 th June 2012	Rockall Bank	<i>Pisces</i> 9	4:18
32	7 th June 2012	Rockall Bank	<i>Pisces</i> 9	4:00
33	8 th June 2012	Rockall Bank	NW Rockall Bank	2:52
34	8 th June 2012	Rockall Bank	NW Rockall Bank	1:14
35	9 th June 2012	Hebrides Terrace	Seamount	6:58
36	10 th June 2012	Hebrides Terrace	Seamount	2:25
37	10 th June 2012	Hebrides Terrace	Seamount	6:34

6.10.2 Preliminary Results

While no formal analysis has been conducted so far, some initial observations on the fauna occurring at each of the sites are summarised here.

Dives 1 – 10, Mingulay: A total of 10 ROV dives were conducted at Mingulay, of which 8 collected useable transect footage. The seabed footage totalled 32 hours, 26 minutes across the Mingulay and Banana Reefs and the surrounding soft-sediment habitats. Unfortunately the visibility during all dives was extremely poor and it is unlikely that the footage from these dives will provide useable quantitative data. Exemplar images taken from the high definition footage are shown in Figure 6.47, showing the high quantities of particulate matter in the water column.



Figure 6.47 Example frame grabs from the high definition video taken within the Mingulay reefs showing the poor visibility at this site. *Pollachius virens* is visible on left hand and *Trisopterus* sp. on right hand image.



Dives 11-29, S Rockall Bank: A total of 20 dives were conducted at the Logachev mounds, of which 10 provided useable transect footage. The seabed footage totalled 30 hours, 2 minutes across three separate mounds (Logachev 1-3) and the surrounding substrate, although one video file (2 hours duration) was corrupted and lost from Dive #26. High numbers of scorpaenids (including *Helicolenus dactylopterus*) appeared to associate with the coral framework, and *Lepidion* sp. and macrourids were also present in high numbers. Smaller numbers of morids, including ling (*Molva molva*) and blue ling (*Molva dipterygia*) were also noted.

Dives 30-34, NW Rockall Bank: A total of five ROV dives were conducted at two sites in the NW Rockall Trough (*Pisces* 9 and NW Rockall Bank) all of which have provided useable transect data. Seabed footage totalled 13 hours, 33 minutes at this location. Coral cover at these sites was noticeably sparser than was encountered at the Logachev Mound province and the transects covered extensive off-reef habitat. The fish fauna appeared to be broadly similar to that seen at the Logachev mounds, though scorpaenids were very highly associated with patches of coral framework at Rockall Bank which may have been due to the relative rarity of the habitat compared to the previous sites.

Dives 35-37, Hebrides Terrace Seamount: A total of 3 ROV dives were conducted at this site, all of which have provided useable transect data. Seabed footage totalled 15 hours, 58 minutes. This site was defined largely by the presence of steep boulder and bedrock slopes on the flanks of the seamount and flat ground on the top, which was covered in soft sediment and gravels. Oreosomatids appeared to dominate around the steeper flanks of the seamount and large morids were also recorded. Macrourids, synphobranchids and halosaurids appeared to be most prevalent on the soft sediment regions.







Specimen Collection: Four fish specimens were collected during the course of the cruise, which have been preserved in 4% buffered formalin solution for formal identification at the University of Glasgow. The specimens are illustrated in Table 6.14.







Table 6.14 Description of fish specimens collected opportunistically during the cruise.

<p>(a)</p>  <p>Indet. sp. A</p> <p><i>Collected at Station 092 from boxcore 03-2. The specimen was found amongst large pieces of living and dead coral framework. Specimen approx. 5 cm total length.</i></p>	<p>(b)</p>  <p>Indet. sp. B (possible Myctophidae)</p> <p><i>Two specimens found in ROV holding tank following dive 28 at station 143. High numbers were seen on the transect video which appeared to be attracted to the ROV. Specimen approx. 5 cm total length.</i></p>
<p>(c)</p>  <p>Scorpaenid sp. 1</p> <p><i>Collected with suction sampler during dive 31 at station 146. Specimen approx. 25 cm total length.</i></p>	

6.10.3 Preliminary fish species catalogue

<p>Family Chimaeridae <i>Chimaera monstrosa</i> Rabbit fish</p>	
<p>Elasmobranch Indet. sp. 1</p>	

<p>Elasmobranch Indet. sp. 2</p>		
<p>Family: Alepocephalidae Indet. sp. 'slickheads'</p>		
<p>Family Oreosomatidae <i>Neocyttus helgae</i> (?) False boarfish</p>		
<p>Family Moridae: <i>Lepidion</i> sp. probably <i>L. eques</i>, but could be <i>L. lepidion</i> in deeper water (>750m)</p>		
<p>Family Moridae: <i>Mora moro</i> Common mora</p>		
<p>Family Lotidae: <i>Molva molva</i> Ling</p>		
<p>Family Lotidae: <i>Molva dipterygia</i> Blue ling</p>		

<p>Family Macrouridae: Indet sp. 1 'rattails'</p>		
<p>Family Macrouridae: Indet sp. 1 (?) 'rattails'</p>		
<p>Family Macrouridae: Indet sp. 2 'rattails'</p>		
<p>Family Phycidae: <i>Phycis blennoides</i> Greater forkbeard</p>		
<p>Family Lophidiidae: <i>Lophius sp.</i> Anglerfish</p>		
<p>Family Sebastidae: <i>Helicolenus dactylopterus</i> Blackbelly rosefish</p>		

<p>Family Sebastidae: <i>Helicolenus dactylopterus</i> Blackbelly rosefish</p>		
<p>Indet. poss. Moridae?</p>		

6.10.3 Future Analysis Planned

On return to the University of Glasgow a complete analysis of the transect footage will be carried out to compare the abundance and diversity of fish species at a large scale (between sample locations), moderate scale (between sites within locations) and at a fine scale (between habitat types within each transect).

6.11 CTD hydrodynamics & carbon biogeochemistry (Helen Findlay and Laura Wicks)

Previous studies of cold-water coral reefs reveal complex hydrodynamics associated with the large mounds, slopes and structures on which the reefs are usually found (e.g. Davies *et al.* 2009). The Mingulay reef complex has been previously studied in relation to the reef habitat, the hydrography and food supply, coral ecophysiology, spatial patterns in biodiversity and temporal reef development (Roberts *et al.* 2009a). As yet, there has not been a specific focus on the biogeochemistry surrounding these reefs. As these reefs form large calcium carbonate structures they could have a significant impact on the carbon chemistry of the local region; they could also be a substantial contributor of respired carbon back to the water column. The complex hydrography surrounding these reefs has the potential to additionally impact the distribution and cycling of carbon throughout the water column; with consequences on carbon sequestration, utilisation, and in turn, could alter the environment in which the reef organisms are living.

The Mingulay reefs are situated in relatively shallow water (150 – 200 m) and are located on the continental shelf surrounding the UK. Therefore, coastal biogeochemical processes potentially influence the reefs. In comparison, the reefs at Logachev on the Rockall bank represent deeper water coral reefs, associated with the open ocean, North Atlantic water. Different biogeochemical processes are therefore likely to be occurring at these different sites.

The JC073 “Changing Oceans” cruise is specifically an ocean acidification research expedition, with several studies being conducted to investigate the potential impacts of ocean acidification on cold-water corals and the associated marine fauna, it is important to be able to characterise the present conditions in relation to the carbon system and ocean acidification (particularly pH and saturations states of aragonite and calcite).

The two main aims of the carbon biogeochemistry aspect of this cruise are:

1. To investigate the existing conditions in terms of carbon biogeochemistry around the Mingulay and Logachev cold-water reefs, as examples of shallow and deep cold-water reef communities, respectively;
2. To investigate how tidally-driven hydrodynamics might impact the reefs presently and with respect to potential future ocean acidification.

Particulate and dissolved organic matter [carbon (POC and DOC, respectively)] are also important components of these biogeochemical systems. The organic matter flux is expected to reflect the food supply to reef and will represent a sink for the inorganic carbon and nutrients. These aspects will therefore also be a major focus of the cruise. The specific objectives relating to organic flux are:

1. To determine the total organic carbon flux to the deep-water reefs, as a proxy for food supply to the corals
2. To compare the DOC flux to deep-water reefs and environmental conditions between the Mingulay Reef Complex and the Logachev mounds
3. To compare DOC and environmental conditions of coral assemblages between the north and south of an isolated mound.

6.11.1 Methods

CTD and hydrographic data: See Section 5.2. for details of CTD configuration, initial data processing and cross-calibration for oxygen and salinity. See Table 5.1. for the list of dates and cast numbers of water sampling. Temperature, salinity, pressure, depth, oxygen, fluorescence and turbidity data were all binned at 0.5 m, saved as ASCII files and imported into Microsoft Excel for quality control. Initial visualisation and plots of CTD data were carried out in Ocean Data View (V4).

Water sampling: Borosilicate glass bottles with ground glass stoppers (50 ml) were used to collect seawater from Niskin bottles on the CTD rosette. Sample bottles were rinsed and filled according to standard procedures detailed in Dickson *et al.* (2007). Samples were poisoned with 10 μl mercuric chloride. Duplicate samples were taken from the same Niskin bottle. Samples were brought into the chemical laboratory and brought to room temperature (approx. 23 °C). Samples were analysed for total inorganic carbon and total alkalinity within 24 hours of collection.

Samples were collected from depths throughout the water column at four sites: Mingulay reef area 1 (and Banana reef), Logachev reef area, PICES site, and the Hebrides Terrace Seamount site. A total of 343 water column samples were collected and analysed for dissolved inorganic carbon and total alkalinity (see carbon metadata spreadsheet for details).

Samples were collected by Helen Findlay, Lisette Victorero Gonzalez and Nigel Lyman (00:00 – 12:00 shift). Samples were collected on the other shift (12:00 – 00:00) by Karl Attard and Geoffrey Cook. All analysis was carried out by Helen Findlay while on the ship, using methods outlined below.

Additional samples ($n = 8$) were collected from the ocean acidification experimental tanks for both dissolved inorganic carbon and total alkalinity measurements using the techniques outlined below during the cruise.

Samples for total alkalinity measurements only were also taken and analysed during the cruise for Janina Büscher (OA experiments, $n = 48$), Seb Hennige, Laura Wicks & Rowan Byrne (OA & CCS experiments, $n = 217$).

In order to obtain large volume filtered samples of the near-bottom water, we used a Stand-Alone Pumping System (SAPS). The SAPS was loaded with two pre-combusted GF/F filters (293 mm diameter) stacked on the bottom plate. The pump was attached to the frame of the Niskin array for deployment. For each deployment, the SAPS was programmed with a delayed start (24 – 54 mins), dependent on the depth at which it was pumping. Once the SAPS was just above the reef, it then commenced pumping for a set period (18-30 mins, see Table 5.3). The pumping efficiency of the SAPS was 600-650 l h^{-1} . After recovery of the SAPS, the loaded GF/F filters were preserved at -80°C.

Dissolved Inorganic Carbon (C_T) analysis: Total dissolved inorganic carbon (C_T) was measured using an automated analyser (repeatability: $\pm 0.1\%$ at $[C_T] \sim 2000 \mu\text{mol/kg}$), Apollo SciTech Dissolved Inorganic Carbon Analyser, Model: AS-C3, s/n: C31202. The analyser adds a strong acid (10% H_3PO_4 plus 10% NaCl solution) which causes all carbon species within the seawater to be converted to CO_2 .

The resulting CO₂ gas is purged from the water sample by the pure nitrogen (N₂) carrier gas. The N₂ gas flow carries the CO₂ from the sample through a drying system that includes a cooling system to reduce water vapour. The concentration of the dried CO₂ gas is then measured with the LI-7000 CO₂ analyser (a differential, non-dispersive, infrared gas analyser). The total amount of CO₂ in the sample was quantified as the integrated area under the concentration-time curve, and converted to C_T using a standard curve created from analysing known volumes of the Certified Reference Materials (Dickson, Batch 113 and Batch 109). A measurement volume of 0.75 ml was used, with up to 5 measurements made from each sample. Values outside a 0.1 % range were excluded from the final result. C_T was corrected with a calibration factor and for the addition of mercuric chloride.

Total alkalinity (A_T) analysis: Total alkalinity (A_T) was measured using the open-cell potentiometric titration method on 12 ml sample volumes using an automated titrator (repeatability: max. ± 0.1 % at Alkalinity ~2300 μmol/kg), Apollo SciTech Alkalinity Titrator Model AS-ALK2, s/n: A2 1002. Calibration was made using Certified Reference Materials (Dickson, Batch 113 and Batch 109). The principal is described by Dickson *et al.* (2007). Replicate measurements were made per sample. A_T was corrected with a calibration factor and for the addition of mercuric chloride.

Organic matter analysis: Upon return to Heriot-Watt University, the filters collected with the SAP will be freeze dried. Analysis of particulate organic carbon and nitrogen on GF/F filters will then be conducted by Dr Kostas Kirakoulakis at Liverpool John Moores University

6.11.2 Preliminary results and conclusions

Mingulay area 1 and Banana reef: A clear tidal signal was found at the Mingulay area, as expected, with a tidal down-welling causing surface waters to reach >120 m, bringing down lower salinity, warmer water, which also has higher oxygen content and a greater amount of chlorophyll (Figs. 6.48, 6.49). The waters around this area had relatively lower salinity and were colder than water from the open-ocean North Atlantic, illustrating potential freshwater land run-off influence in the surface layers.

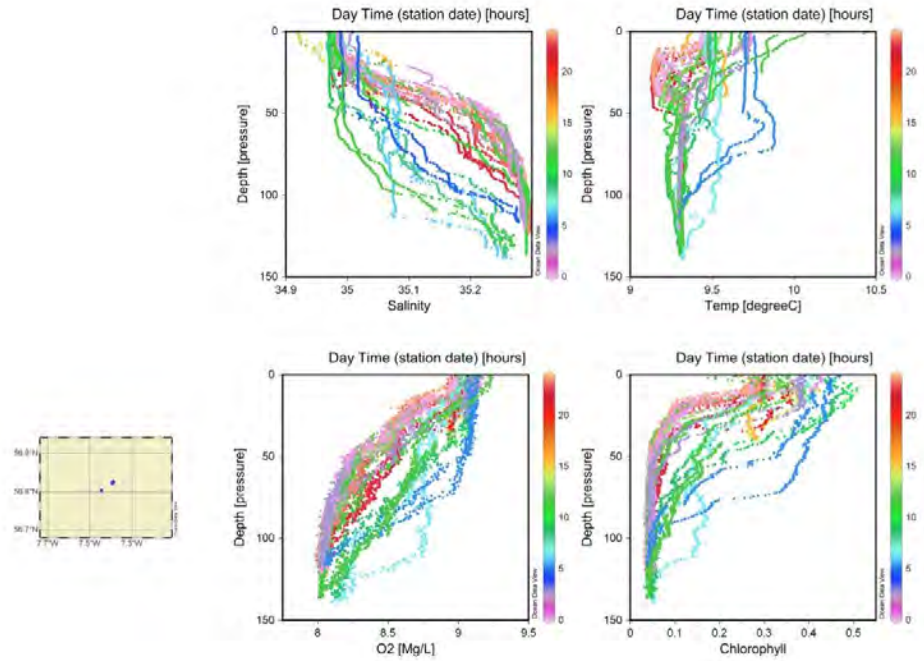

Figure 6.48 Depth profiles for all data from all Mingulay sampling sites: Top left: salinity, top right: temperature (°C), bottom left: oxygen concentration (mg/l), bottom right: Fluorescence (µg/l). The colour bar represents the time of day (24 h).

The downwelling signal is clearly visible through the tidal period, with the peak of the downwelling occurring at high tide. The chlorophyll fluorescence was lower than previous studies (Davies et al 2009).

The carbon dynamics also show a downwelling. The surface waters had lower concentrations of both dissolved inorganic carbon (C_T) and total alkalinity (A_T), most likely as a result of consumption of CO_2 by primary producers combined with the lower salinity waters in the surface. These lower concentrations of C_T and A_T are also drawn-down with the tidal downwelling events, such that the reef will experience lower carbon conditions for a few hours every day. This results in a change in pH at 120 m through the tidal cycle is > 0.08 units, and a change in aragonite saturation state by 0.32.

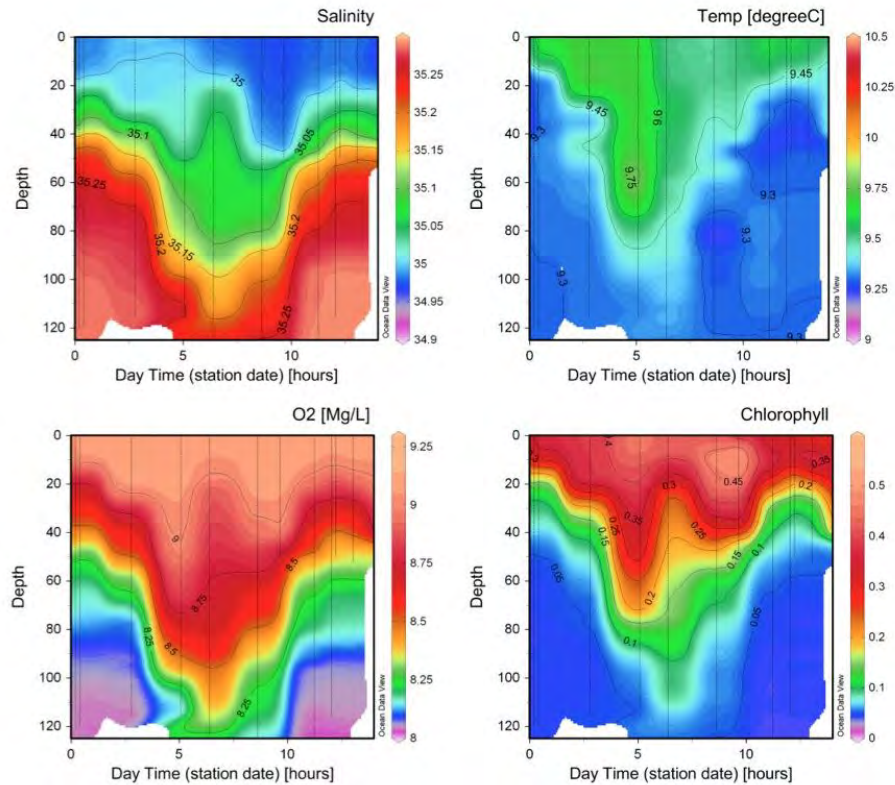

Figure 6.49 CTD data plotted through depth and across one tidal cycle. Top left: salinity, top right: temperature (°C), bottom left: oxygen concentration (mg/l), and bottom right Fluorescence (µg/l).

Logachev reef area: The Logachev area on the south-east edge of the Rockall Bank is influenced by Atlantic water and in particular the North Atlantic Drift (Gulf Stream) water flowing in the near surface. The surface water is therefore relatively warm (11 °C) and saline (35.45). Salinity and temperature both decrease with depth such that at depths where the reefs are found (600 – 800 m) temperature is on average approximately 9 °C, while salinity is <35.35 (Fig. 6.50). There is a large amount of variation in both temperature and salinity at depth across the small region sampled. This variation will be due to different current influences washing over the reef and potentially creating complex eddy dynamics along the slope. At 800 m the temperature ranges from 6.5 to 9.5 °C, while the salinity ranges from 35.2 to 35.35. At 600 m the temperature range is slightly narrower (8 to 10 °C) but the salinity range is similarly about 1.5 psu (35.3 to 35.45).

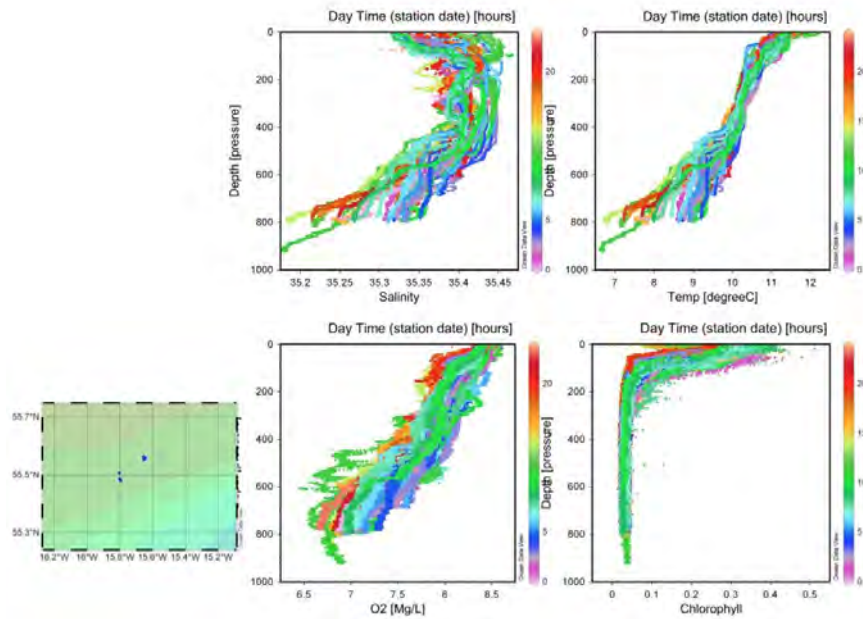

Figure 6.50 Depth profiles for all data from all Logachev sampling sites: Top left: salinity, top right: temperature (°C), bottom left: oxygen concentration (mg/l), bottom right: Fluorescence (µg/l). The colour bar represents the time of day (24 h).

Sampling was carried out through a tidal cycle at two sites: one on the north flank of an isolated reef mound and one on the south flank of the same isolated reef mound. To the north of the mound is the slope up towards Rockall Bank, while the south is open to the deep North Atlantic. At depths associated with the reef (400 – 700 m) there is an observable current influence through the tidal cycle on temperature, salinity (Fig. 6.51) and oxygen. At the south there is an upwelling of cold, lower oxygen water, while on the north side there is no major influx of deep water, rather there is a downwelling of warm oxygen rich water.

Initial assessment of the C_T and A_T shows that these dynamics are reflected in the concentration of carbon and alkalinity, with low carbon surface waters being drawn down at the north, and higher carbon in the deep waters being upwelled onto the reef at the south.

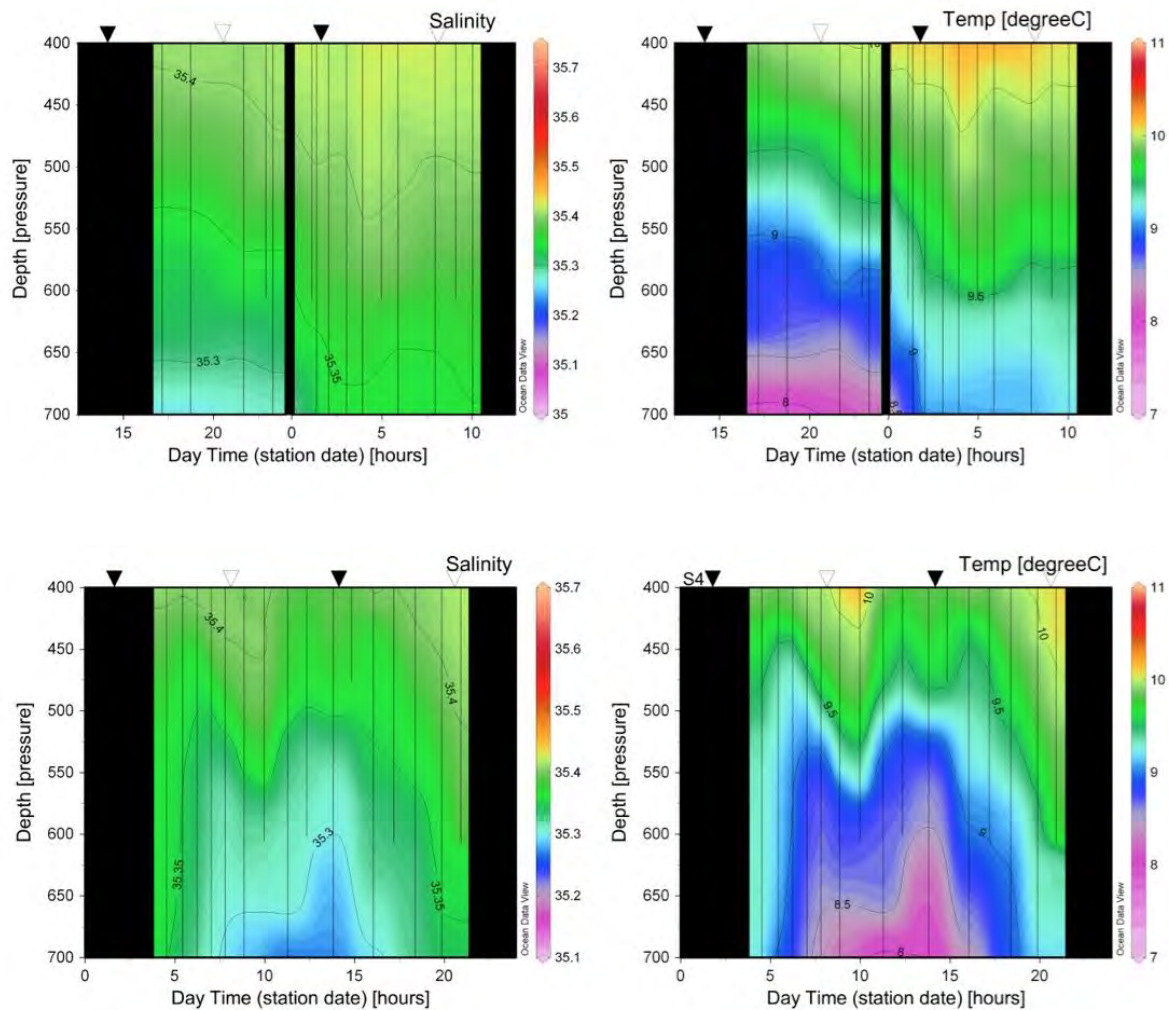

Figure 6.51 Temperature and salinity profiles plotted between 400 and 700 m and across the tidal cycle. Top panels show the North of reef, bottom panels show the South of the reef (note different x-axis arrangement between top and bottom panels). Left panels show salinity, right panels show temperature (°C). White arrows indicate high tide and black arrows indicate low tide (surface tide, data from Ireland).

Pisces area: A coccolithophore bloom had recently occurred over the Rockall Bank, with the *Pisces 9* site being in the middle of the bloom. As a result of this a CTD cast and carbon samples were made at this site (not initially planned). Satellite images of the area showed an extensive, bright area of high calcite (Fig. 6.52). The brightness of the images suggest that the bloom was senescing.

Preliminary assessment of the carbon data suggests that there is a reduction in A_T in the surface waters by about $60-70 \mu\text{mol kg}^{-1}$ compared to the A_T concentration below the thermocline (this is in contrast to other sites which have shown relatively little change in alkalinity through the water column). Surface C_T is also lower, and in accordance with this, chlorophyll fluorescence concentration is high ($>1 \mu\text{g/l}$).

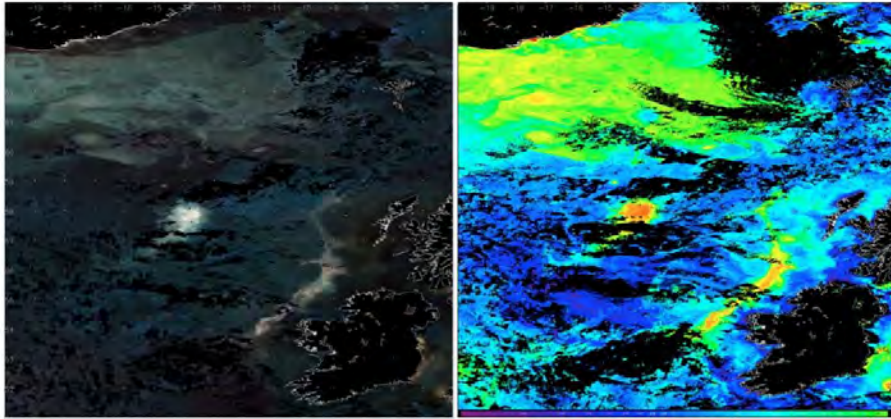

Figure 6.52 Left: Modis RGB satellite weekly composite (01 June – 07 June 2012) showing the bright coccolithophore bloom in location of Rockall Bank. Right: Modis calcite weekly composite for same period and same location.

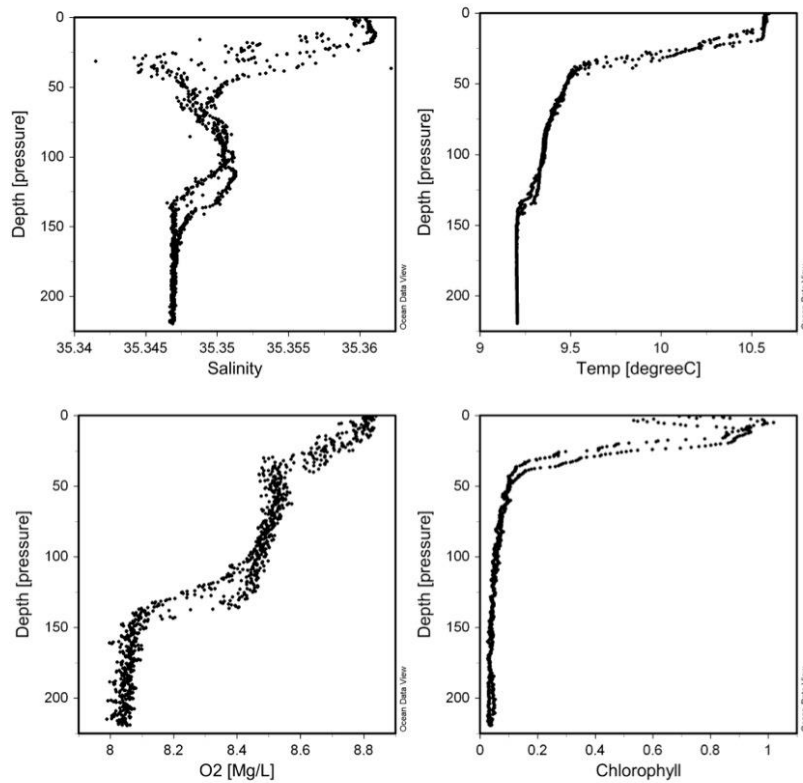

Figure 6.53 Depth profiles for all data at the *Pisces 9* site: top left: salinity, top right: temperature ($^{\circ}\text{C}$), bottom left: oxygen concentration (mg/l), bottom right: fluorescence ($\mu\text{g/l}$).

Hebrides Terrace Seamount area: The Hebrides Terrace Seamount area was the deepest site sampled, with bottom depths at the sampling location >1900 m. There were significant temperature-salinity features at about 500 m and 800 m; potentially internal waves (Fig. 6.54). There was also a strong reduction in oxygen between 800 and 1000 m, with the oxygen minimum at 1000 m. This

matches closely with the depth of the top of the seamount, and could be a result of the heightened benthic activity consuming oxygen at this mid-depth (Fig. 6.54). This is closely matched with the C_T , showing the highest concentration at 1000 m, decreasing rapidly towards the surface and more slowly between 1000 and 2000 m.

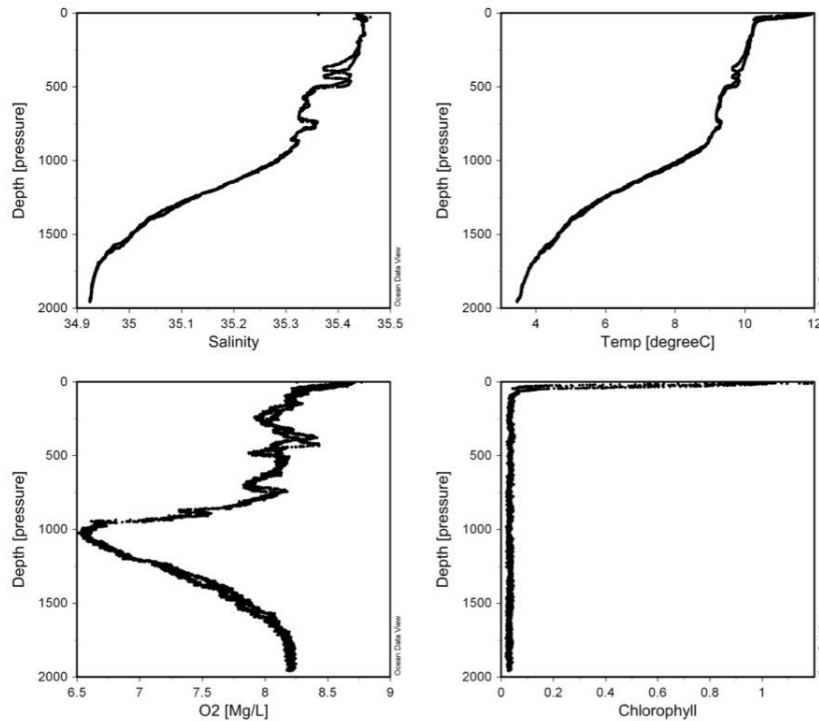

Figure 6.54 Depth profiles for all data at the Hebrides Terrace Seamount site: top left: salinity, top right: temperature (°C), bottom left: oxygen concentration (mg/l), bottom right: Fluorescence (μg/l).

6.11.3 Initial conclusions and future analysis planned

A variety of hydrographical features are associated with cold-water coral reefs, which are characterised by specific biogeochemical parameters. The surface water in all locations showed lower carbon levels than the deeper waters as a result of biological primary production; clear relationships exist between chlorophyll fluorescence and C_T , as well as between C_T and oxygen at all sites, however the extent and slope of these relationships is site specific. The presence of calcifying phytoplankton (coccolithophores) in the surface water also caused a depletion of alkalinity, as would be expected.

At depth there was generally higher C_T particularly associated with the reef areas which have higher respiration compared to areas where reefs are not present. None of the sites surveyed showed waters that were undersaturated with respect to aragonite, however there was a difference in pH and saturation state between sites, especially comparing the shallow reef sites at Mingulay with the deeper reef sites at Logachev.

The complex hydrodynamics of reef systems illustrated that upwelling events can occur potentially bringing more carbon to reefs. In contrast to this, the shallower sites, or sites on the lee side of the

dominant currents appear to be influenced by a downwelling of water. These events not only act to supply food and nutrients to the reef communities, but also could either alleviate, in downwelling cases, or enhance, in upwelling cases, future ocean acidification and warming. More analysis is required to make a proper assessment of this conclusion.

Further quality control of the carbon data will be carried out on all data, including quality checks for oxygen and salinity with bottle data. Data will also be compared with any other available data for the locations studied here (e.g. from the UKOA pelagic cruise 2011, from CEFAS database, and from the CDIAC database). C_T and A_T together with the hydrographic data will be used to calculate the other carbonate system parameters (pH, pCO_2 , aragonite and calcite saturation states) using CO2sys.

Data of the particulate and dissolved organic carbon and nitrogen will be assessed after analyses have been conducted back at the respective universities. These samples were successfully taken at a number of stations over the reefs, as well as during the tidal cycling sampling at both Mingulay and Logachev, and therefore will allow a wider assessment of biogeochemical cycling directly above the reefs. The organic and inorganic carbon will be integrated to investigate the carbon biogeochemical system, as well as the available particle flux (food supply) to the reefs.

Data from the CTD and carbon system will be assessed together with current data from the ADCP, and the data from the MVP.

7. Outreach activities (Laura Wicks & Murray Roberts)

The JC073 Changing Oceans Expedition incorporated several outreach activities. Over the year before the cruise arrangements were made for an at-sea visit to allow school children from Sgoil Lionacleit secondary school on Benbecula and a BBC television film crew to visit the ship while surveying the Mingulay Reef Complex. In the weeks leading up to the cruise a school visit was made to Dean Park Primary School in Edinburgh to explain deep-sea biology and allow years 1-4 to decorate polystyrene cups and predict what would happen when the cups were sent down to 1000 m depth (the 'Dean Park Under Pressure Experiment'). During cruise mobilisation in Govan, Stewart Stephenson MSP (Scottish Government Minister for Environment and Climate Change) visited the ship with Professor Steve Chapman (Principal, Heriot-Watt University). The Sgoil Lionacleit childrens' visit at sea was organised by Heriot-Watt University with Our Dynamic Earth, an earth science outreach centre based in Edinburgh. Following their visit staff from Heriot-Watt and Dynamic Earth visited Sgoil Lionacleit to run facilitated debates on the value of marine protected areas. Similarly, a second visit was made to Dean Park School in Edinburgh to return the childrens' now shrunken cups and show them footage from the JC073 ROV surveys. The BBC film crew were from the Natural History Unit in Bristol who had been commissioned to produce a 5-minute film 'The Deep' presented by Mike Dilger for the One Show (broadcast on 26 March 2013). A blog website was prepared before sailing and daily blogs were posted throughout the cruise.

The BBC and school visit took place on the morning of 20th September. The visitors arrived at 0830 on board *Boy James*, skippered by Donald McLeod from Castlebay (Barra). To stay within lifeboat regulations, 11 scientists then left with *Boy James*, to spend a few hours on the Isle of Barra. The school group was made up of two teachers (Steve Carter and Colin Biddulph), Liz Coutts from Dynamic Earth, and four pupils from S3 and S4: Erin Warner, Magnus Fraser, Angharad Whittle and Anna Biddulph. Scientific work continued while the children were given a tour of the ship, shown a demonstration of ocean acidification and then allowed into the ROV container to see the Mingulay coral reefs live from the ROV. The return boat transfer took place at 1500, when the 11 scientists returned and the school and BBC group left the ship.

The cruise blog (www.changingoceans2012.blogspot.com) was created using Google's Blogger. Every day tweets and Facebook posts updating progress at sea were created via the Heriot-Watt University cold-water coral outreach website www.lophelia.org. Following the school visit, one of the pupils wrote a special blog incorporating her pictures. Sections on the blog website included:

- An 'About' page summarising the Changing Oceans Expedition
- A 'People' page giving information about the scientific, technical and ROV teams
- A 'Science' page describing ocean acidification
- An 'Equipment' page describing the scientific equipment used throughout the cruise
- A 'Sea Creatures' page outlining examples of the animals found on cold-water coral reefs
- A 'Gallery' with images from each week of the expedition, above and below water
- A 'Links and Media' page with information on JC073 coverage.

At the end of the cruise the blog had received more than 20,000 pageviews. Table 7.1 summarises the blog posts made, and the posts are given in Appendix 5.

Table 7.1 Details of blog posts made during JC073

Date	Title	Subject/Guest Author
14/05/2012	And so it begins	Mobilisation
15/05/2012	VIPs, plus scientists with drills	VIP visit and mobilisation
16/05/2012	All aboard	Mobilisation
17/05/2012	The Master Plan	Planning stages
18/05/2012	Day 1: Leaving Glasgow	Leaving dock
19/05/2012	Day 2: Testing Times	Testing equipment
21/05/2012	Day 3: Science Communication Day	BBC and school visit
22/05/2012	Day 4: SPI-ing at Mingulay	SPI camera/Silvana Birchenough
23/05/2012	Day 5: Feeding Corals	Feeding experiments/Cova Orejas
24/05/2012	Day 6: Helen's water	CTD/Helen Findlay
24/05/2012	Sgoil Lionacleit's blog	School experience/Erin Warner (pupil)
25/05/2012	Day 7: Bye Bye Mingulay	Week 1 summary
26/05/2012	Day 8: The Eddy has Landed	Eddy lander/Karl Attard
27/05/2012	Day 9: The Coral Challenge Begins...	Coral experiments/Laura Wicks
28/05/2012	Day 10: Fish and Ships	Fish surveys/Rosanna Milligan
29/05/2012	Day 11: Dissolving Balls	Clod cards/Sebastian Hennige
30/05/2012	Day 12: Hidden Creatures of the Deep	Microbes/Anne Cotton
31/05/2012	Day 13: Underwater Robots	ROV team
1/06/2012	Day 14: Up close and personal with corals	Proteins/Penny Donohue
2/06/2012	Day 15: Capturing Carbon and Corals	CCS/Rowan Byrne
3/06/2012	Day 16: Half-way through and the weather turns	Week 2 summary/Murray Roberts
4/06/2012	Day 17: Pumps and Pageants	SAPS
5/06/2012	Day 18: The Oily Bits	Engine room/Nigel Lyman
6/06/2012	Day 19: Its getting hot in here....	Thermal experiments/Sarah Fitzek
7/06/2012	Day 20: A Sneak Peek at Life on Board	Ship tour
8/06/2012	Day 21: Sponges of the Deep	Sponge experiments/Georgios Kazanidis
9/06/2012	Day 22: Rowing on Rockall	Team work/Geoff Cook
10/06/2012	Day 23: The Coral Doctor explains all.....	Coral physiology/Janina Büscher
11/06/2012	Day 24: Mapping the cold-water coral landscape	Multibeam/Veerle Huvenne
11/06/2012	Special edition: An undergraduates' perspective....	Lisette Victorereo Gonzalez
11/06/2012	SPI-ing on reefs and seamounts	SPI/Silvana Birchenough
12/06/2012	Day 25: Bloomin' Ocean	CTD/Helen Findlay
13/06/2012	Day 26: Mud, Glorious Mud	Coring/Claudia Alt
14/06/2012	Day 27: Homeward bound	MVP/Juan Moreno Navas
15/06/2012	Day 28: They think it's all over, it is now	End cruise/Murray Roberts

8. References

- Ainsworth TD, Thurber RV, Gates RD (2010) The future of coral reefs: a microbial perspective. *Trends in Ecology & Evolution* 25: 233-240
- Andreae MO (1990) Ocean-atmosphere interactions in the global biogeochemical sulfur cycle. *Marine Chemistry* 30: 1-29
- Angel-Dapa MA, Rodríguez-Jaramillo C, Cáceres-Martínez CJ, Saucedo PE (2010) Changes in lipid content of oocytes of the penshell *Atrina maura* as a criterion of gamete development and quality: a study of histochemistry and digital image analysis. *Journal of Shellfish Research* 29: 407-413
- Al-Horani FA, Ferdelman T, Al-Moghrabi SM, De Beer D (2005) Spatial distribution of calcification and photosynthesis in the scleractinian coral *Galaxea fascicularis*. *Coral Reefs* 142: 419-426
- Belchier M, Clemmesen C, Cortes D, Doan T, Folkvord A, Garcia A, Geffen A, Høie H, Johannessen A, Moksness E (2004) Recruitment studies: manual on precision and accuracy of tools. In: *ICES Techniques in Marine Environmental Sciences* 33: International Council for the Exploration of the Sea: 44 pp.
- Ben-David-Zaslow R, Benayahu Y (1999) Temporal variation in lipid, protein and carbohydrate content in the Red Sea soft coral *Heteroxenia fucusescens*. *Journal of the Marine Biological Association of the UK* 79: 1001-1006
- Birchenough SNR, Boyd, SE, Coggan, RA, Limpenny, DS, Meadows, WL, Rees, HL (2006) Lights, camera and acoustics: assessing macrobenthic communities at a dredged material disposal site off the North East coast of the UK. *Journal of Marine Systems* 62: 204–216
- Broadbent A, Jones G (2004) DMS and DMSP in mucus ropes, coral mucus, surface films and sediment pore waters from coral reefs in the Great Barrier Reef. *Marine and Freshwater Research* 55: 849-855
- Buhl-Mortensen L, Vanreusel A, Gooday AJ, Levin LA, Priede IG, Buhl-Mortensen P, Gheerardyn H, King NJ, Raes M (2010) Biological structures as a source of habitat heterogeneity and biodiversity on the deep ocean margins. *Marine Ecology* 31: 21-50
- Burgess SN, Babcock RC (2005) Reproductive ecology of three reef-forming, deep-sea corals in the New Zealand region. In: Freiwald A, Roberts JM (eds) *Cold-water Corals and Ecosystems*. Springer-Verlag Berlin Heidelberg pp. 701-713
- Cáceres-Puig JI, Cáceres-Martínez C, Saucedo PE (2009) Annual reproductive effort of Pacific winged pearl *Oyster pteria* sterna and its relation with the timing for planning pearl seeding operations. *Journal of Shellfish Research* 28: 471-476
- Carlier A, Le Guilloux E, Olu K, Sarrazin J, Mastrototaro F, Taviani M, Clavier J (2009) Trophic relationships in a deep Mediterranean cold-water coral bank (Santa Maria di Leuca, Ionian Sea). *Marine Ecology Progress Series* 397: 125-137
- Clemmesen C (1993) Improvements in the fluorometric-determination of the RNA and DNA content of individual marine fish larvae. *Marine Ecology Progress Series* 100: 177-183

- Coma R, Gili JM, Zabala M (1995) Trophic ecology of a benthic marine hydroid, *Campanularia everta*. Marine Ecology Progress Series 119: 211-220
- Costello MJ, McCrea M, Freiwald A, Lundalv T, Jonsson L, Bett BJ, van Weering TCE, de Haas H, Roberts JM, Allen D (2005) Role of cold-water *Lophelia pertusa* coral reefs as fish habitat in the NE Atlantic. In: Freiwald A, Roberts JM (Eds.) Cold-Water Corals and Ecosystems. Springer, Berlin, Heidelberg, pp. 771-805
- Davies AJ, Duineveld GCA, Lavaleye MSS, Bergman MJN, van Haren H, Roberts JM (2009) Downwelling and deep-water bottom currents as food supply mechanisms to the cold-water *Lophelia pertusa* (Scleractinia) at the Mingulay Reef complex. Limnology and Oceanography 54: 620-629
- DeBose JL, Lema SC, Nevitt GA (2008) Dimethylsulphoniopropionate (DMSP) as a foraging cue for reef fish. *Science* 319: 1356
- Dickson AG (1990) Thermodynamics of the dissociation of boric acid in potassium chloride solutions from 273.15 to 318.15 K. Journal of Chemical Engineering Data 35: 253-257
- Dickson AG, Millero FJ (1987) A comparison of the equilibrium constants for the dissociation of carbonic acid in seawater media. Deep-Sea Research Part a-Oceanographic Research Papers 34: 1733-1743
- Dickson AG, Sabine CL, Christian JR (2007) Guide to best practices for ocean CO₂ measurements. PICES Special Publication 3, IOCC Report No. 8
- Dodds LA (2007) The ecophysiology of the cold-water coral *Lophelia pertusa* (Scleractinia). Doctoral Thesis, Scottish Association for Marine Science. University of Aberdeen: 206 pp.
- Dodds LA, Black KD, Orr H, Roberts JM (2009) Lipid biomarkers reveal geographical differences in food supply to the cold-water coral *Lophelia pertusa* (Scleractinia). Marine Ecology Progress Series 397: 113-124
- Dong LF, Smith CJ, Papaspyrou S, Stott A, Osborn AM, Nedwell DB (2009) Changes in benthic denitrification, nitrate ammonification, and anammox process rates and nitrate and nitrite reductase gene abundances along an estuarine nutrient gradient (the Colne Estuary, United Kingdom) Applied and Environmental Microbiology. 10: 3171-3179
- Galkiewicz JP, Pratte ZA, Gray MA, Kellogg CA (2011) Characterization of culturable bacteria isolated from the cold-water coral *Lophelia pertusa*. FEMS Microbiology Ecology 77: 333-346
- Gatti S, Brey T, Müller WEG, Heilmayer O, Holst G (2002) Oxygen microoptodes: a new tool for oxygen measurements in aquatic animal ecology. Marine Biology 140: 1075-1085
- Gori A, Linares C, Rossi S, Coma R, Gili JM (2007) Spatial variability in reproductive cycle of the gorgonians *Paramuricea clavata* and *Eunicella singularis* (Anthozoa, Octocorallia) in the Western Mediterranean Sea. Marine Biology 151: 1571-1584
- Großkurth AK (2007) Analysis of bacterial community composition on the cold-water coral *Lophelia pertusa* and antibacterial effects of coral extracts. Diploma thesis in marine environmental sciences. Carl Von Ossietzky Universität, Oldenburg, Germany.

- Guinotte JM, Orr J, Cairns S, Freiwald A, Morgan L, George R (2006) Will human-induced changes in seawater chemistry alter the distribution of deep-sea scleractinian corals? *Frontiers in Ecology and the Environment* 4: 141-146
- Gutperlet R (2008) Ökophysiologische Studien an der Kaltwasserkoralle *Lophelia pertusa* (Scleractinia). Diploma Thesis, IFM-GEOMAR, Kiel: Christian-Albrechts-University: 92 pp.
- Hansen HP (1999) Determination of oxygen. In: Grasshoff K, Kremling K, Ehrhardt M (eds) *Methods of Seawater Analysis*. Verlag Chemie pp. 75-89
- Hatcher A (1989) RQ of benthic invertebrates. *Marine Biology* 102: 445–452
- Jensen A, Frederiksen E (1992) The fauna associated with the bankforming deepwater coral *Lophelia pertusa* (Scleractinaria) on the Faroe shelf. *Sarsia* 77: 53-69
- Kellogg CA, Lisle JT, Galkiewicz JP (2009) Culture-independent characterization of bacterial communities associated with the cold-water coral *Lophelia pertusa* in the northeastern Gulf of Mexico. *Applied and Environmental Microbiology* 75: 2294-2303
- Kiriakoulakis K, Bett BJ, White M, Wolff GA (2004) Organic biogeochemistry of the Darwin Mounds, a deep-water coral ecosystem, of the NE Atlantic. *Deep-Sea Research Part I-Oceanographic Research Papers* 51: 1937-1954
- Kiriakoulakis K, Fisher L, Freiwald A, Grehan A, Roberts JM, Wolff GA (2005) Lipids and nitrogen isotopes of two deep-water corals from the North-East Atlantic: initial results and implications for their trophic regime. In: Freiwald A, Roberts JM (eds) *Cold-water corals and ecosystems*. Springer pp. 715-729
- Kiriakoulakis K, Freiwald A, Fisher E, Wolff GA (2007) Organic matter quality and supply to deep-water coral/mound systems of the NW European Continental Margin. *International Journal of Earth Sciences* 96: 159-170
- Klitgaard AB (1995) The fauna associated with outer shelf and upper slope sponges (Porifera, Demospongiae) at the Faroe Islands, Northeastern Atlantic. *Sarsia* 80: 1-22
- Longo C, Mastrototaro F, Corriero G (2005) Sponge fauna associated with a Mediterranean deep-sea coral bank. *Journal of the Marine Biological Association of the United Kingdom* 85: 1341-1352
- Lorke A, McGinnis D, Maeck A (submitted) Eddy-correlation measurements of benthic oxygen fluxes: Effects of coordinate transformations and averaging time scales. *Limnology and Oceanography: Methods*.
- Masood A, Stark KD, Salem Jr N (2005) A simplified and efficient method for the analysis of fatty acid methyl esters suitable for large clinical studies. *Journal of Lipid Research* 46: 2299-2305
- Mehrbach C, Culbertson CH, Hawley JE, Pytkowicz RN (1973) Measurement of the apparent dissociation constants of carbonic acid in seawater at atmospheric pressure. *Limnology and Oceanography* 18: 897-907

- Millero F, Woosley R, Ditrolio B, Waters J (2009) Effect of ocean acidification on the speciation of metals in seawater. *Oceanography* 22: 72-85
- Moodley L, Boschker HTS, Middelburg JJ, Pel R, Herman PMJ, De Deckere E, Heip CHR (2000) Ecological significance of benthic foraminifera: ^{13}C labelling experiments. *Marine Ecology Progress Series* 202: 289-295
- Morrison CL, Eackles MS, Johnson RL, King TL (2008) Characterization of 13 microsatellite loci for the deep-sea coral, *Lophelia pertusa* (Linnaeus 1758), from the western North Atlantic Ocean and Gulf of Mexico. *Molecular Ecology Resources* 8: 1037-1039
- Neulinger SC, Järnegren J, Ludvigsen M, Lochte K, Dullo W-C (2008) Phenotype-specific bacterial communities in the cold-water coral *Lophelia pertusa* (Scleractinia) and their implications for the coral's nutrition, health and distribution. *Applied and Environmental Microbiology*. 74: 7272-7285
- Neulinger SC, Gärtner A, Järnegren J, Ludvigsen M, Lochte K, Dullo W-C (2009) Tissue-associated "*Candidatus* Mycoplasma corallicola" and filamentous bacteria on the cold-water coral *Lophelia pertusa* (Scleractinia). *Applied and Environmental Microbiology* 75: 1473-1444
- Nilsson HC, Rosenberg R (1997) Benthic habitat quality assessment of an oxygen stressed fjord by surface and sediment profile images. *Journal of Marine Systems* 11: 249-264
- Ohde S, Hossain M (2004) Effect of CaCO_3 (aragonite) saturation state of seawater on calcification of *Porites* coral. *Geochemical Journal* 38: 613-621
- Orejas C, Gili JM, López-Gonzalez PJ, Arntz WE (2001) Feeding strategies and diet composition of four Antarctic cnidarian species. *Polar Biol* 24: 620-627
- Orejas C, Gili JM, Arntz WE (2003) The role of the small planktonic communities in the diet of two Antarctic octocorals (*Primnoisis antarctica* and *Primnoella* sp.). *Marine Ecology Progress Series* 250: 105-116
- Pascal P, Fleeger J, Galvez F, Carman K (2010) The toxicological interaction between ocean acidity and metals in coastal meiobenthic copepods. *Marine Pollution Bulletin* 60: 2201-2208
- Pierrot DE, Lewis, Wallace DWR (2006) MS Excel Program Developed for CO_2 System Calculations. ORNL/CDIAC-105a. Carbon Dioxide Information Analysis Center, Oak Ridge National Laboratory, U.S. Department of Energy, Oak Ridge, Tennessee.
- Pile AJ, Young CM (2006) The natural diet of a hexactinellid sponge: benthic-pelagic coupling in a deep-sea microbial food web *Deep-Sea Research I* 53: 1148-1156
- Purser A, Larsson AI, Thomsen L, van Oevelen D (2010) The influence of flow velocity and food concentration on *Lophelia pertusa* (Scleractinia) zooplankton capture rates. *Journal of Experimental Marine Biology and Ecology* 395: 55-62
- Quattrini AM, Ross SW, Carlson MCT, Nizinski MS (2012) Megafaunal-habitat associations at a deep-sea coral mound off North Carolina, USA. *Marine Biology* 159: 1079-1094
- Revsbech NP (1989) An oxygen microsensor with a guard cathode. *Limnology and Oceanography* 34: 474-478

- Revsbech NP, & Jørgensen BB (1986) Microelectrodes: their use in microbial ecology. *Advances in Microbial Ecology* 9: 293-352
- Roberts JM, Davies AJ, Henry LA, Dodds LA, Duineveld GCA, Lavaleye MSS, Maier C, van Soest RWM, Bergman MJN, Hühnerbach V, Huvenne VAI, Sinclair DJ, Watmough T, Long D, Green SL, van Haren H (2009a) Mingulay reef complex: an interdisciplinary study of cold-water coral habitat, hydrography and biodiversity. *Marine Ecology Progress Series* 397: 139-151
- Roberts JM, Wheeler AJ, Freiwald A (2006) Reefs of the deep: The biology and geology of cold-water coral ecosystems. *Science* 312: 543-547
- Roberts JM, Wheeler A, Freiwald A, Cairns S (2009b) Cold-water corals. Cambridge University Press 334 pp.
- Ross SW, Quattrini AM (2007) The fish fauna associated with deep coral banks off the southeastern United States. *Deep-sea Research I* 54: 975-1007
- Rossi S, Gili JM, Coma R, Linares C, Gori A, Vert N (2006) Seasonal cycles of protein, carbohydrate and lipid concentrations in *Paramuricea clavata*: (Anthozoa, Octocorallia): evidences for summer-autumn feeding constraints. *Marine Biology* 149: 643-65
- Schöttner S, Hoffmann F, Wild C, Rapp HT, Boetius A, Ramette A (2009) Inter- and intra-habitat bacterial diversity associated with cold-water corals. *The ISME Journal* 3: 756-759
- Schöttner S, Wild C, Hoffmann F, Boetius A, Ramette A (2012) Spatial scales of bacterial diversity in cold-water coral reef ecosystems. *PLoS ONE* 7: e32093. doi:10.1371/journal.pone.0032093
- Smith CJ, Nedwell DB, Dong LF, Osborn AM (2007). Diversity and abundance of nitrate reductase genes (*narG* and *napA*) nitrite reductase genes (*nirS* and *nrfA*), and their transcripts in estuarine sediments. *Applied and Environmental Microbiology* 73: 3612-362
- Smith SV, Key GS (1975) Carbon dioxide and metabolism in marine environments. *Limnology and Oceanography*. 20: 493-495
- Söffker M, Sloman KA, Hall-Spencer JM (2011) In situ observations of fish associated with coral reefs off Ireland. *Deep-sea Research I* 58: 818-825
- Sulak KJ, Brooks RA, Luke KE *et al.* (2007) Demersal fishes associated with *Lophelia pertusa* coral and hard-substrate biotopes on the continental slope, northern Gulf of Mexico. In: George RY, Cairns SD (Eds.). Conservation and adaptive management of seamount and deep-sea coral ecosystems. Rosenstiel School of Marine and Atmospheric Science, University of Miami. pp. 65-92
- Sunda W, Kieber DJ, Kiene RP, Huntsman S (2002) An antioxidant function for dimethylsulphoniopropionate (DMSP) and dimethylsulphide (DMS) in marine algae. *Nature* 18: 317-320
- Tatián M, Sahade R, Kowalke J, Kivatinitz SC, Esnal GB (2002) Food availability and gut contents in the ascidian *Cnemidocarpa verrucosa* at Potter Cove, Antarctica. *Polar Biology* 25: 58-64
- Tsounis G, Orejas C, Reynaud S, Gili JM, Allemand D, Ferrier-Pagès C (2010) Prey capture rates in four Mediterranean cold water corals. *Marine Ecology Progress Series* 398: 149-155

- Van Alstyne KL, Puglisi MP (2007) DMSP in marine macroalgae and macroinvertebrates: distribution, function and ecological impacts. *Aquatic Science* 69: 394-402
- van Duyl FC, Hegeman J, Hoogstraten A, Maier C (2008) Dissolved carbon fixation by sponge-microbe consortia of deep water coral mounds in the northeastern Atlantic Ocean. *Marine Ecology Progress Series* 358: 137-150
- van Oevelen D, Duineveld G, Lavaleye M, Mienis F, Soetaert K, Heip CHR (2009) The cold-water coral community as a hot spot for carbon cycling on continental margins: A food-web analysis from Rockall Bank (northeast Atlantic). *Limnology and Oceanography* 54: 1829-1844
- van Soest RWM, Cleary DFR, de Kluijver MJ, Lavaleye MSS, Maier C, van Duyl FC (2007) Sponge diversity and community composition in Irish bathyal coral reefs. *Contributions to Zoology* 76: 121-142
- van Soest RWM, Lavaleye MSS (2005) Diversity and abundance of sponges in bathyal coral reefs of Rockall Bank, NE Atlantic, from boxcore samples. *Marine Biology Research* 1: 338-349
- Waller RG, Tyler PA (2005) The reproductive biology of two deep-water, reef-building scleractinians from the NE Atlantic Ocean. *Coral Reefs* 24:514-522
- Wilczac JM, Oncley SP, Stage SA (2001) Sonic anemometer tilt correction algorithms. *Boundary-Layer Meteorology* 99: 127-150
- Wild C, Mayr C, Wehrmann L, Schoettner S, Naumann M, Hoffmann F, Rapp HT (2008) Organic matter release by cold water corals and its implication for fauna-microbe interaction. *Marine Ecology Progress Series* 372: 67-75
- Yahel G, Whitney F, Reiswig HM, Eerkes-Medrano DI, Leys SP (2007) In situ feeding and metabolism of glass sponges (Hexactinellida, Porifera) studied in a deep temperate fjord with a remotely operated submersible. *Limnology and Oceanography* 52: 428-440
- Yost DM, Jones RJ, Mitchelmore CL (2010) Alterations in dimethylsulphoniopropionate (DMSP) levels the coral *Monastreaafranskii* in response to copper exposure. *Aquatic Toxicology* 98: 367-373

Appendix 1: Station List

Coloured highlighting in table corresponds to: Yellow/Red, missing information; Green, no entry in ship's Eventlog or OFOP, data from manual log sheets; Purple, entries corrected and differ from the Sample Logs; Light Blue, taken from bridge log.

Site	Final sample number	JDay Start	Start Date	Start Time GMT	Start Lat Degr N	Start Lat Min N	Start Long Degr W	Start Long Min W	Start depth meter	Equip depth meter	ship or USBL position	End Date	End Time GMT	End Lat Degr N	End Lat Min N	End Long Degr W	End Long Min W	End depth meter	Comments
Mingulay1	JC073_001_CTD	140	19/05/2012	14:44:00	56	49.597	7	23.41	178	39	ship								record for CTD at bottom
	JC073_001_CTDh01	140	19/05/2012	15:24:00	56	49.597	7	23.41	178		ship								
	JC073_001_CTDh02	140	19/05/2012	15:24:00	56	49.597	7	23.41	178		ship								
	JC073_001_CTDh03	140	19/05/2012	15:24:00	56	49.597	7	23.41	178		ship								
	JC073_001_CTDh04	140	19/05/2012	15:25:00	56	49.597	7	23.41	178		ship								
	JC073_001_CTDh05	140	19/05/2012	15:25:00	56	49.597	7	23.41	178		ship								
	JC073_001_CTDh06	140	19/05/2012	15:26:00	56	49.597	7	23.41	178		ship								
	JC073_001_CTDh07	140	19/05/2012	15:26:00	56	49.597	7	23.41	178		ship								
	JC073_001_CTDh08	140	19/05/2012	15:27:00	56	49.597	7	23.41	178		ship								
	JC073_001_CTDh09	140	19/05/2012	15:27:00	56	49.597	7	23.41	178		ship								
	JC073_001_CTDh10	140	19/05/2012	15:27:00	56	49.597	7	23.41	178		ship								
	JC073_001_CTDh11	140	19/05/2012	15:28:00	56	49.597	7	23.41	178		ship								
	JC073_001_CTDh12	140	19/05/2012	15:28:00	56	49.597	7	23.41	178		ship								
	JC073_001_CTDh13	140	19/05/2012	15:29:00	56	49.597	7	23.41	178		ship								
	JC073_001_CTDh14	140	19/05/2012	15:29:00	56	49.597	7	23.41	178		ship								
	JC073_001_CTDh15	140	19/05/2012	15:29:00	56	49.597	7	23.41	178		ship								
	JC073_001_CTDh16	140	19/05/2012	15:30:00	56	49.597	7	23.41	178		ship								
	JC073_001_CTDh17	140	19/05/2012	15:30:00	56	49.597	7	23.41	178		ship								
	JC073_001_CTDh18	140	19/05/2012	15:30:00	56	49.597	7	23.41	178		ship								
	JC073_001_CTDhWP	140	19/05/2012	14:44:00	56	49.597	7	23.41	178	39	ship	19/05/2012			49.59584	7	23.41138	39	Deep-water pumping to fill aquaria
	JC073_001_CTDh20	140	19/05/2012	15:31:00	56	49.597	7	23.41	178		ship								
	JC073_001_CTDh21	140	19/05/2012	15:31:00	56	49.597	7	23.41	178		ship								
	JC073_001_CTDh22	140	19/05/2012	15:31:00	56	49.597	7	23.41	178		ship								
	JC073_001_CTDh23	140	19/05/2012	15:31:00	56	49.597	7	23.41	178		ship								
	JC073_001_CTDh24	140	19/05/2012	15:32:00	56	49.597	7	23.41	178		ship								
Mingulay1	JC073_002_SPI	140	19/05/2012	16:57:25	56	49.59508	7	23.41115	180	180	ship								Test of SPI camera, fault with video feed, camera OK, record for SPI at bottom
Mingulay1	JC073_003_ROV01	140	19/05/2012	19:15:13	56	49.60704	7	23.39229	179.5	179.5	usbl	19/05/2012	22:59:18	56	49.51518	7	23.476992		Records are ROV on bottom and ROV leaves seabed
	JC073_003_ROV01/BIOB07	140	19/05/2012	19:52:41	56	49.56759	7	23.41638	169.6	169.6	usbl								
	JC073_003_ROV01/BIOB08	140	19/05/2012	20:13:17	56	49.567482	7	23.416758	169.4	169.4	usbl								
	JC073_003_ROV01/BIOB09	140	19/05/2012	20:41:28	56	49.567152	7	23.41683	168.9	168.9	usbl								
	JC073_003_ROV01/BIOB09	140	19/05/2012	20:50:56	56	49.567248	7	23.416728	168.7	168.7	usbl								
	JC073_003_ROV01/BIOB11	140	19/05/2012	21:03:49	56	49.567092	7	23.416962	168.6	168.6	usbl								
	JC073_003_ROV01/BIOB07	140	19/05/2012	21:10:00	56	49.566942	7	23.416812	168.5	168.5	usbl								
	JC073_003_ROV01/BIOB10	140	19/05/2012	21:28:33	56	49.566972	7	23.417508	168.4	168.4	usbl								
Helisav	JC073_004_SVP	141	20/05/2012	01:20:29	57	0.2398	7	13.2843	211		ship								SVP for upcoming multibeam survey - time is SVP at bottom
Helisav	JC073_005_MBES	141	20/05/2012	02:05:00	57	0.2398	7	13.2843	211		ship	20/05/2012	06:35:00	56	57.58669	7	13.04018	198	
	JC073_005_MBES/710	141	20/05/2012	02:05:00	57	0.2398	7	13.2843	211		ship	20/05/2012	06:35:00	56	57.58669	7	13.04018	199	
	JC073_005_MBES/SBP	141	20/05/2012	02:26:00	56	59.8167	7	11.65	120		ship	20/05/2012	06:35:00	56	57.58669	7	13.04018	199	
Mingulay1	JC073_006_ROV02	141	20/05/2012	10:49:59	56	49.35552	7	23.7558	129		usbl	20/05/2012	12:27:14	56	49.28724	7	23.68332	119	ROV dive for schoolchildren and BBC
Mingulay1	JC073_007_ROV03	141	20/05/2012	17:19:09	56	49.381218	7	23.710098	125		usbl	20/05/2012	19:25:37	56	57.58669	7	13.04018	134	Records are ROV on bottom and ROV leaves seabed
	JC073_007_ROV03_BIOB02	141	20/05/2012	17:51:09	56	49.389528	7	23.69517	128.4	128.4	usbl								Sponge
	JC073_007_ROV03_BIOB02	141	20/05/2012	17:57:28	56	49.38987	7	23.695332	128.3	128.3	usbl								Sponge
	JC073_007_ROV03_BIOB02	141	20/05/2012	18:00:36	56	49.389348	7	23.698938	128.1	128.1	usbl								Sponge
	JC073_007_ROV03_BIOB02	141	20/05/2012	18:08:45	56	49.390098	7	23.69463	128.5	128.5	usbl								Sponge
	JC073_007_ROV03_BIOB02	141	20/05/2012	18:24:25	56	49.38792	7	23.692458	127.3	127.3	usbl								Sponge
	JC073_007_ROV03_BIOB02	141	20/05/2012	18:25:02	56	49.388112	7	23.69244	127.4	127.4	usbl								Sponge
	JC073_007_ROV03_BIOB02	141	20/05/2012	18:28:47	56	49.387878	7	23.69277	127.1	127.1	usbl								Sponge
	JC073_007_ROV03_BIOB02	141	20/05/2012	18:31:59	56	49.388202	7	23.692548	127.6	127.6	usbl								Sponge
	JC073_007_ROV03_BIOB03	141	20/05/2012	19:41:58	56	49.380618	7	23.687958	127.1	127.1	usbl								Lophelia
Mingulay1	JC073_008_CTD	141	20/05/2012	20:57:00	56	49.35	7	23.725	123	33.5	ship								record for CTD at bottom
	JC073_008_CTD/DWP	141	20/05/2012	20:57:00	56	49.35	7	23.725	123	33.5	ship	20/05/2012	21:53:00	56	49.35	7	23.725	123	Pumping water for aquaria
Mingulay1	JC073_009_CTD	141	20/05/2012	22:09:00	56	49.35	7	23.722	123		ship	21/05/2012	00:41:00	56	49.351	7	23.722	122	
	JC073_009_CTDa	141	20/05/2012	22:25:00	56	49.351	7	23.723	117	115	ship								Yo-Yo CTD
	JC073_009_CTDb	141	20/05/2012	22:46:00	56	49.351	7	23.722	117	117	ship								with PAR sensor - record is at bottom
	JC073_009_CTDc	141	20/05/2012	23:02:00	56	49.351	7	23.722	117	117	ship								with PAR sensor - record is at bottom
	JC073_009_CTDd	141	20/05/2012	23:17:00	56	49.351	7	23.722	117	117	ship								with PAR sensor - record is at bottom
	JC073_009_CTDe	141	20/05/2012	23:33:00	56	49.351	7	23.722	117	117	ship								with PAR sensor - record is at bottom
	JC073_009_CTDf	141	20/05/2012	23:48:00	56	49.351	7	23.722	117	117	ship								with PAR sensor - record is at bottom
	JC073_009_CTDg	142	21/05/2012	00:03:00	56	49.351	7	23.722	117	117	ship								with PAR sensor - record is at bottom
	JC073_009_CTDh	142	21/05/2012	00:19:00	56	49.351	7	23.722	117	117	ship								with PAR sensor - record is at bottom
Mingulay1	JC073_010_SPI	142	21/05/2012	01:18:00	56	50.23732	7	24.00668	203		ship	21/05/2012	03:28:00	56	50.2266	7	23.4143	200	SPI transect
	JC073_010_SPI/A	142	21/05/2012	01:18:00	56	50.23732	7	24.00668	203		ship	21/05/2012	02:00:00	56	50.2401	7	24.009		Section A: 5 dips
	JC073_010_SPI/B	142	21/05/2012	02:20:00	56	50.2335	7	23.7137			ship	21/05/2012	02:45:00	56	50.2303	7	23.708		Section B: 5 dips
	JC073_010_SPI/C	142	21/05/2012	02:57:00	56	50.2295	7	23.4143			ship	21/05/2012	03:28:00	56	50.2266	7	23.4101		Section C: 5 dips
Mingulay1																			

	JC073_012_SPI/A	142	21/05/2012	08:18:00	56	49.0897	7	23.69378	175	ship	21/05/2012	08:30:00	56	49.0879	7	23.708	Section A: 5 dips	
	JC073_012_SPI/B	142	21/05/2012	08:50:49	56	49.0943	7	23.9042	205	ship	21/05/2012	09:03:00	56	49.0924	7	23.9188	Section B: 5 dips	
	JC073_012_SPI/C	142	21/05/2012	09:20:00	56	49.0965	7	24.1158	212	ship	21/05/2012	09:29:00	56	49.09581	7	24.12662	Section C: 5 dips	
Mingulay1	JC073_013_SPI	142	21/05/2012	09:39:00	56	49.13018	7	24.04667	211	ship	21/05/2012	10:28:00	56	49.3048	7	23.044	SPI transect with 2 sections	
	JC073_013_SPI/A	142	21/05/2012	09:39:00	56	49.13018	7	24.04667	211	ship	21/05/2012	09:48:00	56	49.2169	7	23.0341	Section A: 5 dips	
	JC073_013_SPI/B	142	21/05/2012	10:14:00	56	49.2973	7	23.0443	145	ship	21/05/2012	10:28:00	56	49.3048	7	23.044	Section B: 5 dips	
Mingulay1	JC073_014_SPI	142	21/05/2012	10:50:00	56	49.68528	7	24.03296	184	ship	21/05/2012	11:35:00	56	49.57158	7	24.03394	SPI transect with 2 sections	
	JC073_014_SPI/A	142	21/05/2012	10:50:00	56	49.68528	7	24.03296	184	ship	21/05/2012	11:07:00	56	49.6842	7	24.0333	Section A: 3 dips	
	JC073_014_SPI/B	142	21/05/2012	11:19:00	56	49.5756	7	24.0383	165	ship	21/05/2012	11:35:00	56	49.57158	7	24.03394	Section B: 3 dips	
Mingulay1	JC073_015_CTD	142	21/05/2012	12:07:00	56	49.356	7	23.73	122	ship							record for CTD at bottom	
	JC073_015_CTD/SAPS	142	21/05/2012	12:20:00	56	49.356	7	23.73	122	ship	21/05/2012	12:50:00	49.356	7	23.73	122	30 min pumping	
	JC073_015_CTD/h01	142	21/05/2012	12:52:00	56	49.356	7	23.73	122	ship								
	JC073_015_CTD/h02	142	21/05/2012	12:52:00	56	49.356	7	23.73	122	ship								
	JC073_015_CTD/h03	142	21/05/2012	12:53:00	56	49.356	7	23.73	122	ship								
	JC073_015_CTD/h04	142	21/05/2012	12:53:00	56	49.356	7	23.73	122	ship								
	JC073_015_CTD/h05	142	21/05/2012	12:53:00	56	49.356	7	23.73	122	ship								
	JC073_015_CTD/h06	142	21/05/2012	12:53:00	56	49.356	7	23.73	122	ship								
	JC073_015_CTD/h07	142	21/05/2012	12:54:00	56	49.356	7	23.73	122	ship								
	JC073_015_CTD/h08	142	21/05/2012	12:54:00	56	49.356	7	23.73	122	ship								
	JC073_015_CTD/h09	142	21/05/2012	12:54:00	56	49.356	7	23.73	122	ship								
	JC073_015_CTD/h10	142	21/05/2012	12:55:00	56	49.356	7	23.73	122	ship								
	JC073_015_CTD/h11	142	21/05/2012	12:57:00	56	49.356	7	23.73	122	ship								
	JC073_015_CTD/h12	142	21/05/2012	12:57:00	56	49.356	7	23.73	122	ship								
	JC073_015_CTD/h13	142	21/05/2012	13:01:00	56	49.356	7	23.73	122	ship								
	JC073_015_CTD/h14	142	21/05/2012	13:01:00	56	49.356	7	23.73	122	ship								
	JC073_015_CTD/h15	142	21/05/2012	13:03:00	56	49.356	7	23.73	122	ship								
	JC073_015_CTD/h16	142	21/05/2012	13:04:00	56	49.356	7	23.73	122	ship								
	JC073_015_CTD/h17	142	21/05/2012	13:07:00	56	49.356	7	23.73	122	ship								
	JC073_015_CTD/h18	142	21/05/2012	13:08:00	56	49.356	7	23.73	122	ship								
	JC073_015_CTD/h19	142	21/05/2012	13:10:00	56	49.356	7	23.73	122	ship								
	JC073_015_CTD/h22	142	21/05/2012	13:10:00	56	49.356	7	23.73	122	ship								
	JC073_015_CTD/h23	142	21/05/2012	13:12:00	56	49.356	7	23.73	122	ship								
	JC073_015_CTD/h24	142	21/05/2012	13:12:00	56	49.356	7	23.73	122	ship								
Mingulay1	JC073_016_MVP	142	21/05/2012	14:23:45	56	49.47962	7	23.61209	155	ship	22/05/2012							
Mingulay1	JC073_017_BC	143	22/05/2012	01:04:00	56	49.81061	7	23.27824	190	ship							record is for BC in water - on seabed was not recorded. Core failed	
Mingulay1	JC073_018_BC	143	22/05/2012	02:18:00	56	49.79984	7	23.27703	191	ship							record is for BC in water - on seabed was not recorded. Core failed; didn't fire	
Mingulay1	JC073_019_BC	143	22/05/2012	02:33:00	56	49.80015	7	23.27678	192	ship							record is for BC in water - on seabed was not recorded. Core failed	
Mingulay1	JC073_020_BC	143	22/05/2012	03:35:00	56	50.15951	7	23.06073	194	ship							record is for BC in water - on seabed was not recorded. Core failed	
Mingulay1	JC073_021_BC	143	22/05/2012	04:35:00	56	50.26617	7	23.06175	201	ship							record is for BC in water - on seabed was not recorded. Core failed; did not fire	
Mingulay1	JC073_022_BC	143	22/05/2012	05:11:00	56	50.22907	7	23.2693	201	ship							record is for BC in water - on seabed was not recorded. Core failed	
Mingulay1	JC073_023_CTD	143	22/05/2012	06:33:00	56	49.404	7	23.483	144	ship	22/05/2012	06:58:00	56	49.404	7	23.483	144	record is for CTD at bottom
	JC073_023_CTD/SAPS	143	22/05/2012	07:00:00	56	49.404	7	23.483	144	ship							16 min pumpin	
	JC073_023_CTD/h01	143	22/05/2012	07:00:00	56	49.404	7	23.483	144	ship								
	JC073_023_CTD/h02	143	22/05/2012	07:00:00	56	49.404	7	23.483	144	ship								
	JC073_023_CTD/h03	143	22/05/2012	07:03:00	56	49.404	7	23.483	144	ship								
	JC073_023_CTD/h04	143	22/05/2012	07:04:00	56	49.404	7	23.483	144	ship								
	JC073_023_CTD/h05	143	22/05/2012	07:06:00	56	49.404	7	23.483	144	ship								
	JC073_023_CTD/h06	143	22/05/2012	07:07:00	56	49.404	7	23.483	144	ship								
	JC073_023_CTD/h07	143	22/05/2012	07:11:00	56	49.404	7	23.483	144	ship								
	JC073_023_CTD/h08	143	22/05/2012	07:11:00	56	49.404	7	23.483	144	ship								
	JC073_023_CTD/h09	143	22/05/2012	07:15:00	56	49.404	7	23.483	144	ship								
	JC073_023_CTD/h10	143	22/05/2012	07:15:00	56	49.404	7	23.483	144	ship								
	JC073_023_CTD/h11	143	22/05/2012	07:18:00	56	49.404	7	23.483	144	ship								
	JC073_023_CTD/h12	143	22/05/2012	07:18:00	56	49.404	7	23.483	144	ship								
	JC073_023_CTD/h13	143	22/05/2012	07:20:00	56	49.404	7	23.483	144	ship								
	JC073_023_CTD/h14	143	22/05/2012	07:20:00	56	49.404	7	23.483	144	ship								
	JC073_023_CTD/h15	143	22/05/2012	07:22:00	56	49.404	7	23.483	144	ship								
	JC073_023_CTD/h16	143	22/05/2012	07:22:00	56	49.404	7	23.483	144	ship								
	JC073_023_CTD/h17	143	22/05/2012	07:22:00	56	49.404	7	23.483	144	ship								
	JC073_023_CTD/h18	143	22/05/2012	07:22:00	56	49.404	7	23.483	144	ship								
	JC073_023_CTD/h19	143	22/05/2012	07:23:00	56	49.404	7	23.483	144	ship								
	JC073_023_CTD/h23	143	22/05/2012	07:23:00	56	49.404	7	23.483	144	ship								
	JC073_023_CTD/h24	143	22/05/2012	07:23:00	56	49.404	7	23.483	144	ship								
Mingulay1	JC073_024_CTD	143	22/05/2012	08:49:00	56	49.404	7	23.686	144	ship	22/05/2012	09:15:00	56	49.404	7	23.686	144	record is for CTD at bottom
	JC073_024_CTD/SAPS	143	22/05/2012	08:33:00	56	49.404	7	23.686	144	ship							18 min pumping	
	JC073_024_CTD/h01	143	22/05/2012	09:18:00	56	49.404	7	23.686	144	ship								
	JC073_024_CTD/h02	143	22/05/2012	09:18:00	56	49.404	7	23.686	144	ship								
	JC073_024_CTD/h03	143	22/05/2012	09:21:00	56	49.404	7	23.686	144	ship								
	JC073_024_CTD/h04	143	22/05/2012	09:21:00	56	49.404	7	23.686	144	ship								
	JC073_024_CTD/h05	143	22/05/2012	09:26:00	56	49.404	7	23.686	144	ship								
	JC073_024_CTD/h06	143	22/05/2012	09:26:00	56	49.404	7	23.686	144	ship								
	JC073_024_CTD/h07	143	22/05/2012	09:34:00	56	49.404	7	23.686	144	ship								
	JC073_024_CTD/h08	143	22/05/2012	09:34:00	56													

	JC073_024_CTDn23	143	22/05/2012	09:50:00	56	49.404	7	23.686	144	3	ship							
	JC073_024_CTDn24	143	22/05/2012	09:50:00	56	49.404	7	23.686	144	3	ship							
Mingulay1	JC073_025_CTD	143	22/05/2012	11:27:00	56	49.403	7	23.484	142	138	ship							
	JC073_025_CTD/SAPS	143	22/05/2012	11:05:00	56	49.403	7	23.484	142	138	ship	22/05/2012	11:23:00	56	49.403	7	23.484	142
	JC073_025_CTDn01	143	22/05/2012	12:00:00	56	49.403	7	23.484	142	135	ship							
	JC073_025_CTDn02	143	22/05/2012	12:00:00	56	49.403	7	23.484	142	135	ship							
	JC073_025_CTDn03	143	22/05/2012	12:02:00	56	49.403	7	23.484	142	130	ship							
	JC073_025_CTDn04	143	22/05/2012	12:03:00	56	49.403	7	23.484	142	130	ship							
	JC073_025_CTDn05	143	22/05/2012	12:06:00	56	49.403	7	23.484	142	110	ship							
	JC073_025_CTDn06	143	22/05/2012	12:06:00	56	49.403	7	23.484	142	110	ship							
	JC073_025_CTDn07	143	22/05/2012	12:10:00	56	49.403	7	23.484	142	80	ship							
	JC073_025_CTDn08	143	22/05/2012	12:10:00	56	49.403	7	23.484	142	80	ship							
	JC073_025_CTDn09	143	22/05/2012	12:14:00	56	49.403	7	23.484	142	50	ship							
	JC073_025_CTDn10	143	22/05/2012	12:14:00	56	49.403	7	23.484	142	50	ship							
	JC073_025_CTDn11	143	22/05/2012	12:17:00	56	49.403	7	23.484	142	20	ship							
	JC073_025_CTDn12	143	22/05/2012	12:17:00	56	49.403	7	23.484	142	20	ship							
	JC073_025_CTDn13	143	22/05/2012	12:19:00	56	49.403	7	23.484	142	10	ship							
	JC073_025_CTDn14	143	22/05/2012	12:20:00	56	49.403	7	23.484	142	10	ship							
	JC073_025_CTDn15	143	22/05/2012	12:22:00	56	49.403	7	23.484	142	3	ship							
	JC073_025_CTDn16	143	22/05/2012	12:22:00	56	49.403	7	23.484	142	3	ship							
	JC073_025_CTDn17	143	22/05/2012	12:23:00	56	49.403	7	23.484	142	3	ship							
	JC073_025_CTDn18	143	22/05/2012	12:23:00	56	49.403	7	23.484	142	3	ship							
	JC073_025_CTDn19	143	22/05/2012	12:23:00	56	49.403	7	23.484	142	3	ship							
	JC073_025_CTDn22	143	22/05/2012	12:24:00	56	49.403	7	23.484	142	3	ship							
	JC073_025_CTDn23	143	22/05/2012	12:24:00	56	49.403	7	23.484	142	3	ship							
	JC073_025_CTDn24	143	22/05/2012	12:25:00	56	49.403	7	23.484	142	3	ship							
Mingulay1	JC073_026_ROV	143	22/05/2012	13:09:26	56	49.364322	7	23.727342	134		usbl	22/05/2012	14:42:29	56	49.35670 2	7	23.709738	
	JC073_026_ROV/BIOB03	143	22/05/2012	13:21:05	56	49.359162	7	23.715702		119	usbl							
	JC073_026_ROV/BIOB03	143	22/05/2012	13:27:30	56	49.359228	7	23.715948		118.9	usbl							
	JC073_026_ROV/BIOB04	143	22/05/2012	13:47:26	56	49.359663	7	23.716548		119.3	usbl							
	JC073_026_ROV/BIOB04	143	22/05/2012	13:51:00	56	49.35972	7	23.716098		119.2	usbl							
	JC073_026_ROV/BIOB04	143	22/05/2012	13:58:51	56	49.359738	7	23.716488		119.1	usbl							
	JC073_026_ROV/BIOB04	143	22/05/2012	14:02:08	56	49.35972	7	23.716398		119.4	usbl							
	JC073_026_ROV/BIOB04	143	22/05/2012	14:06:39	56	49.35966	7	23.715972		119.6	usbl							
	JC073_026_ROV/BIOB04	143	22/05/2012	14:10:11	56	49.359762	7	23.71599		119.4	usbl							
	JC073_026_ROV/BIOB04	143	22/05/2012	14:14:40	56	49.359798	7	23.715678		119.3	usbl							
	JC073_026_ROV/BIOB04	143	22/05/2012	14:18:20	56	49.359468	7	23.715768		119.8	usbl							
	JC073_026_ROV/BIOB04	143	22/05/2012	14:25:16	56	49.359492	7	23.71473		119.3	usbl							
Mingulay1	JC073_027_ROV05	143	22/05/2012	16:48:24	56	49.367928	7	23.702178	133		usbl	22/05/2012	23:45:22	56	49.37583	7	23.703792	
	JC073_027_ROV05/BIOB05	143	22/05/2012	17:13:46	56	49.369248	7	23.694228	135		usbl							
	JC073_027_ROV05/BIOB05	143	22/05/2012	17:18:21	56	49.369008	7	23.693988	135		usbl							
	JC073_027_ROV05/BIOB05	143	22/05/2012	17:21:08	56	49.369212	7	23.693982	135		usbl							
	JC073_027_ROV05/BIOB06	143	22/05/2012	17:34:17	56	49.36812	7	23.689548	137		usbl							
	JC073_027_ROV05/BIOB06	143	22/05/2012	17:36:44	56	49.368198	7	23.68938	137		usbl							
	JC073_027_ROV05/BIOB06	143	22/05/2012	17:44:50	56	49.368408	7	23.68968	137		usbl							
	JC073_027_ROV05/BIOB06	143	22/05/2012	18:01:24	56	49.36887	7	23.690442	137		usbl							
	JC073_027_ROV05/BIOB06	143	22/05/2012	18:05:30	56	49.368702	7	23.690718	137		usbl							
	JC073_027_ROV05/BIOB06	143	22/05/2012	18:07:55	56	49.368438	7	23.69004	137		usbl							
	JC073_027_ROV05/BIOB06	143	22/05/2012	18:09:26	56	49.368552	7	23.69022	137		usbl							
	JC073_027_ROV05/BIOB06	143	22/05/2012	18:14:55	56	49.368072	7	23.68974	133		usbl							
	JC073_027_ROV05/BIOB07	143	22/05/2012	18:20:22	56	49.36788	7	23.689998	133		usbl							
	JC073_027_ROV05/BIOB07	143	22/05/2012	18:31:16	56	49.367892	7	23.690148	133		usbl							
	JC073_027_ROV05/BIOB07	143	22/05/2012	18:33:43	56	49.367898	7	23.68962	133		usbl							
	JC073_027_ROV05/BIOB07	143	22/05/2012	18:36:12	56	49.367838	7	23.6898	133		usbl							
	JC073_027_ROV05/BIOB07	143	22/05/2012	18:39:21	56	49.36818	7	23.689452	133		usbl							
	JC073_027_ROV05/BIOB08	143	22/05/2012	18:44:22	56	49.367988	7	23.689308	133		usbl							
	JC073_027_ROV05/BIOB08	143	22/05/2012	18:46:59	56	49.368102	7	23.68935	133		usbl							
	JC073_027_ROV05/BIOB08	143	22/05/2012	18:50:49	56	49.367922	7	23.68941	133		usbl							
	JC073_027_ROV05/BIOB08	143	22/05/2012	18:53:50	56	49.36797	7	23.689788	133		usbl							
	JC073_027_ROV05/BIOB08	143	22/05/2012	18:56:24	56	49.368	7	23.689722	133		usbl							
	JC073_027_ROV05/BIOB01	143	22/05/2012	19:16:05	56	49.370232	7	23.693982	136		usbl							
	JC073_027_ROV05/BIOB01	143	22/05/2012	19:21:19	56	49.370382	7	23.69544	136		usbl							
	JC073_027_ROV05/BIOB01	143	22/05/2012	19:24:32	56	49.370712	7	23.694762	136		usbl							
	JC073_027_ROV05/BIOB01	143	22/05/2012	19:27:34	56	49.370478	7	23.694378	136		usbl							
	JC073_027_ROV05/BIOB01	143	22/05/2012	19:30:37	56	49.370562	7	23.69463	136		usbl							
	JC073_027_ROV05/BIOB01	143	22/05/2012	19:37:53	56	49.370472	7	23.69415	136		usbl							
	JC073_027_ROV05/BIOB02	143	22/05/2012	19:53:02	56	49.374792	7	23.697192	134		usbl							
	JC073_027_ROV05/BIOB03	143	22/05/2012	19:57:39	56	49.375458	7	23.696538	134		usbl							
	JC073_027_ROV05/BIOB03	143	22/05/2012	20:03:26	56	49.37517	7	23.696362	134		usbl							
	JC073_027_ROV05/MBIO01	143	22/05/2012	21:07:54	56	49.377768	7	23.70339	133		usbl							
	JC073_027_ROV05/MBIO02	143	22/05/2012	21:26:59	56	49.37757	7	23.70348	133		usbl							

	JC073_028_CTDh04	144	23/05/2012	00:51:00	56	49.352	7	23.72	126	109	ship								
	JC073_028_CTDh05	144	23/05/2012	00:53:00	56	49.352	7	23.72	126	100	ship								
	JC073_028_CTDh06	144	23/05/2012	00:53:00	56	49.352	7	23.72	126	100	ship								
	JC073_028_CTDh07	144	23/05/2012	00:55:00	56	49.352	7	23.72	126	79	ship								
	JC073_028_CTDh08	144	23/05/2012	00:56:00	56	49.352	7	23.72	126	79	ship								
	JC073_028_CTDh09	144	23/05/2012	00:57:00	56	49.352	7	23.72	126	50	ship								
	JC073_028_CTDh10	144	23/05/2012	00:57:00	56	49.352	7	23.72	126	50	ship								
	JC073_028_CTDh11	144	23/05/2012	01:01:00	56	49.352	7	23.72	126	20	ship								
	JC073_028_CTDh12	144	23/05/2012	01:01:00	56	49.352	7	23.72	126	20	ship								
	JC073_028_CTDh13	144	23/05/2012	01:04:00	56	49.352	7	23.72	126	10	ship								
	JC073_028_CTDh14	144	23/05/2012	01:04:00	56	49.352	7	23.72	126	10	ship								
	JC073_028_CTDh15	144	23/05/2012	01:06:00	56	49.352	7	23.72	126	1.8	ship								
	JC073_028_CTDh16	144	23/05/2012	01:07:00	56	49.352	7	23.72	126	1.6	ship								
	JC073_028_CTDh17	144	23/05/2012	01:07:00	56	49.352	7	23.72	126	1.7	ship								
	JC073_028_CTDh18	144	23/05/2012	01:07:00	56	49.352	7	23.72	126	1.9	ship								
	JC073_028_CTDh19	144	23/05/2012	01:07:00	56	49.352	7	23.72	126	2.4	ship								
	JC073_028_CTDh22	144	23/05/2012	01:08:00	56	49.352	7	23.72	126	1.5	ship								
	JC073_028_CTDh23	144	23/05/2012	01:08:00	56	49.352	7	23.72	126	1.6	ship								
	JC073_028_CTDh24	144	23/05/2012	01:08:00	56	49.352	7	23.72	126	1.7	ship								
Mingulay1	JC073_029_CTD	144	23/05/2012	02:55:00	56	49.352	7	23.732	123	116	ship								
	JC073_029_CTD/SAPS	144	23/05/2012	03:04:00	56	49.352	7	23.732	123	116	ship	23/05/2012	03:22:00	56	49.352	7	23.732	123	record is for CTD at bottom
	JC073_029_CTDh01	144	23/05/2012	03:22:00	56	49.352	7	23.732	123	114	ship								18 m pumping
	JC073_029_CTDh02	144	23/05/2012	03:22:00	56	49.352	7	23.732	123	114	ship								
	JC073_029_CTDh03	144	23/05/2012	03:26:00	56	49.352	7	23.732	123	110	ship								
	JC073_029_CTDh04	144	23/05/2012	03:26:00	56	49.352	7	23.732	123	110	ship								
	JC073_029_CTDh05	144	23/05/2012	03:28:00	56	49.352	7	23.732	123	100	ship								
	JC073_029_CTDh06	144	23/05/2012	03:29:00	56	49.352	7	23.732	123	100	ship								
	JC073_029_CTDh07	144	23/05/2012	03:32:00	56	49.352	7	23.732	123	80	ship								
	JC073_029_CTDh08	144	23/05/2012	03:32:00	56	49.352	7	23.732	123	80	ship								
	JC073_029_CTDh09	144	23/05/2012	03:36:00	56	49.352	7	23.732	123	50	ship								
	JC073_029_CTDh10	144	23/05/2012	03:36:00	56	49.352	7	23.732	123	50	ship								
	JC073_029_CTDh11	144	23/05/2012	03:39:00	56	49.352	7	23.732	123	20	ship								
	JC073_029_CTDh12	144	23/05/2012	03:40:00	56	49.352	7	23.732	123	20	ship								
	JC073_029_CTDh13	144	23/05/2012	03:42:00	56	49.352	7	23.732	123	10	ship								
	JC073_029_CTDh14	144	23/05/2012	03:43:00	56	49.352	7	23.732	123	10	ship								
	JC073_029_CTDh15	144	23/05/2012	03:44:00	56	49.352	7	23.732	123	2	ship								
	JC073_029_CTDh16	144	23/05/2012	03:45:00	56	49.352	7	23.732	123	2	ship								
	JC073_029_CTDh17	144	23/05/2012	03:45:00	56	49.352	7	23.732	123	2	ship								
	JC073_029_CTDh18	144	23/05/2012	03:45:00	56	49.352	7	23.732	123	2	ship								
	JC073_029_CTDh19	144	23/05/2012	03:46:00	56	49.352	7	23.732	123	2	ship								
	JC073_029_CTDh22	144	23/05/2012	03:46:00	56	49.352	7	23.732	123	2	ship								
	JC073_029_CTDh23	144	23/05/2012	03:47:00	56	49.352	7	23.732	123	2	ship								
	JC073_029_CTDh24	144	23/05/2012	03:47:00	56	49.352	7	23.732	123	2	ship								
Mingulay1	JC073_030_CTD	144	23/05/2012	05:14:00	56	49.351	7	23.722	123	114	ship								
	JC073_030_CTD/SAPS	144	23/05/2012	05:20:00	56	49.351	7	23.722	123	114	ship	23/05/2012	05:38:00	56	49.351	7	23.722	123	record is for CTD at bottom
	JC073_030_CTDh01	144	23/05/2012	05:17:00	56	49.351	7	23.722	123	114	ship								18 m pumping
	JC073_030_CTDh02	144	23/05/2012	05:17:00	56	49.351	7	23.722	123	114	ship								
	JC073_030_CTDh03	144	23/05/2012	05:18:00	56	49.351	7	23.722	123	114	ship								
	JC073_030_CTDh04	144	23/05/2012	05:18:00	56	49.351	7	23.722	123	114	ship								
	JC073_030_CTDh05	144	23/05/2012	05:18:00	56	49.351	7	23.722	123	114	ship								
	JC073_030_CTDh06	144	23/05/2012	05:41:00	56	49.351	7	23.722	123	110	ship								
	JC073_030_CTDh07	144	23/05/2012	05:41:00	56	49.351	7	23.722	123	110	ship								
	JC073_030_CTDh08	144	23/05/2012	05:41:00	56	49.351	7	23.722	123	110	ship								
	JC073_030_CTDh09	144	23/05/2012	05:43:00	56	49.351	7	23.722	123	100	ship								
	JC073_030_CTDh10	144	23/05/2012	05:43:00	56	49.351	7	23.722	123	100	ship								
	JC073_030_CTDh11	144	23/05/2012	05:43:00	56	49.351	7	23.722	123	100	ship								
	JC073_030_CTDh12	144	23/05/2012	05:45:00	56	49.351	7	23.722	123	80	ship								
	JC073_030_CTDh13	144	23/05/2012	05:45:00	56	49.351	7	23.722	123	80	ship								
	JC073_030_CTDh14	144	23/05/2012	05:48:00	56	49.351	7	23.722	123	50	ship								
	JC073_030_CTDh15	144	23/05/2012	05:48:00	56	49.351	7	23.722	123	50	ship								
	JC073_030_CTDh16	144	23/05/2012	05:51:00	56	49.351	7	23.722	123	20	ship								
	JC073_030_CTDh17	144	23/05/2012	05:51:00	56	49.351	7	23.722	123	20	ship								
	JC073_030_CTDh18	144	23/05/2012	05:51:00	56	49.351	7	23.722	123	20	ship								
	JC073_030_CTDh19	144	23/05/2012	05:53:00	56	49.351	7	23.722	123	10	ship								
	JC073_030_CTDh22	144	23/05/2012	05:53:00	56	49.351	7	23.722	123	10	ship								
	JC073_030_CTDh23	144	23/05/2012	05:55:00	56	49.351	7	23.722	123	2	ship								
	JC073_030_CTDh24	144	23/05/2012	05:55:00	56	49.351	7	23.722	123	2	ship								
Mingulay1	JC073_031_SBP	144	23/05/2012	06:06:00	56	49.359	7	23.346	139		ship	23/05/2012	07:18:00	56	49.037	7	23.925	205	SBP120 survey to find good coring sites
Mingulay1	JC073_032_GC	144	23/05/2012	07:30:24	56	49.03701	7	23.92335	205		ship								Pull-out: 1.67T - ca. 1.75 m recovery. Core overpenetrated - lost top
Mingulay1	JC073_033_GC	144	23/05/2012	08:22:11	56	49.03735	7	23.92303	205		ship								Pull-out: 2.04T - ca. 1.6 m recovery. Core disturbed: had to hammer out of barrel
Mingulay1	JC073_034_GC	144	23/05/2012	09:23:05	56	49.2979	7	23.7427	116		ship								Pull-out: 1.70T - ca. 0.5m recovery, coral.
Mingulay1	JC073_035_GC	144	23/05/2012	10:09:22	56	49.51472	7	23.58363	162		ship								Pull-out: 2.11T - ca. 1m recovery
Mingulay1	JC073_036_GC	144	23/05/2012	10:57:56	56	49.51529	7	23.58341	163		ship								Pull-out: 2.02T - ca. 1m recovery
Mingulay1	JC073_037_GC	144	23/05/2012	11:46:36	56	49.0355	7	23.92341	205		ship								Pull-out: 2.07T - ca. 2.50m recovery
Mingulay1	JC073_038_ROV06	144	23/05/2012	12:58:21	56	49.34142	7	23.76219	121		usbl	23/05/2012	13:55:57	56	49.32546	7	23.754762	121	Records are ROV on bottom and ROV leaves seabed
	JC073_038_ROV06/EDDY	144	23/05/2012	13:37:29	56	49.325658	7	23.7525	121		usbl	24/05/2012	14:50:42	56	49.32708	7	23.75133		eddy correlation lander placed on seabed
Banana	JC073_039_ROV07	144	23/05/2012	16:00:26	56	48.131988	7	27.006612	153		usbl	23/05/2012	19:47:14	56	48.39334	7	25.96767	163	ROV systems file missing
	JC073_039_ROV07/SUC	144	23/05/2012	16:39:40	56	48.146148	7	26.974668			usbl								anemone
	JC073_039_ROV07/MBIO01	144	23/05/2012	18:21:59															

	JC073_053_CTDn22	147	26/05/2012	03:33:00	55	33.399	15	39.113	3		ship											
	JC073_053_CTDn23	147	26/05/2012	03:33:00	55	33.399	15	39.113	3		ship											
	JC073_053_CTDn24	147	26/05/2012	03:34:00	55	33.399	15	39.113	3		ship											
Logachev1	JC073_054_CTD	147	26/05/2012	05:01:00	55	33.4	15	39.11	689	677	ship	26/05/2012	05:34:00	55	33.4	15	39.11	689			record is for CTD at bottom	
	JC073_054_CTD/SAPS	147	26/05/2012	05:10:00	55	33.4	15	39.11	689	677	ship										24 min pumping	
	JC073_054_CTDn01	147	26/05/2012	05:33:00	55	33.4	15	39.11	689	678	ship											
	JC073_054_CTDn02	147	26/05/2012	05:33:00	55	33.4	15	39.11	689	678	ship											
	JC073_054_CTDn03	147	26/05/2012	05:33:00	55	33.4	15	39.11	689	678	ship											
	JC073_054_CTDn04	147	26/05/2012	05:47:00	55	33.4	15	39.11	689	350	ship											
	JC073_054_CTDn05	147	26/05/2012	05:47:00	55	33.4	15	39.11	689	350	ship											
	JC073_054_CTDn06	147	26/05/2012	05:47:00	55	33.4	15	39.11	689	350	ship											
	JC073_054_CTDn07	147	26/05/2012	05:55:00	55	33.4	15	39.11	689	150	ship											
	JC073_054_CTDn08	147	26/05/2012	05:55:00	55	33.4	15	39.11	689	150	ship											
	JC073_054_CTDn09	147	26/05/2012	05:55:00	55	33.4	15	39.11	689	70	ship											
	JC073_054_CTDn10	147	26/05/2012	05:59:00	55	33.4	15	39.11	689	70	ship											
	JC073_054_CTDn11	147	26/05/2012	05:59:00	55	33.4	15	39.11	689	70	ship											
	JC073_054_CTDn12	147	26/05/2012	05:59:00	55	33.4	15	39.11	689	70	ship											
	JC073_054_CTDn13	147	26/05/2012	06:02:00	55	33.4	15	39.11	689	25	ship											
	JC073_054_CTDn14	147	26/05/2012	06:02:00	55	33.4	15	39.11	689	25	ship											
	JC073_054_CTDn15	147	26/05/2012	06:02:00	55	33.4	15	39.11	689	25	ship											
	JC073_054_CTDn16	147	26/05/2012	06:04:00	55	33.4	15	39.11	689	15	ship											
	JC073_054_CTDn17	147	26/05/2012	06:04:00	55	33.4	15	39.11	689	15	ship											
	JC073_054_CTDn18	147	26/05/2012	06:04:00	55	33.4	15	39.11	689	15	ship											
	JC073_054_CTDn19	147	26/05/2012	06:04:00	55	33.4	15	39.11	689	15	ship											
	JC073_054_CTDn22	147	26/05/2012	06:05:00	55	33.4	15	39.11	689	3	ship											
	JC073_054_CTDn23	147	26/05/2012	06:06:00	55	33.4	15	39.11	689	3	ship											
	JC073_054_CTDn24	147	26/05/2012	06:06:00	55	33.4	15	39.11	689	3	ship											
Logachev1	JC073_055_MBES	147	26/05/2012	06:10:00	55	33.4	15	39.114	702		ship	26/05/2012	10:25:00	55	34.268	15	32.587	808			short survey of Logachev area to find coring stations	
	JC073_055_MBS/SBP	147	26/05/2012	06:10:00	55	33.4	15	39.114	702		ship	26/05/2012	10:25:00	55	34.268	15	32.587	808			short survey of Logachev area to find coring stations	
Logachev1	JC073_056_MOOR02	147	26/05/2012	11:13:53	55	33.56634	15	37.27335	616		ship	05/06/2012	14:40:00	55	33.63241	15	36.90154				current meter mooring deployment and recovery	
Logachev1	JC073_057_ROV11	147	26/05/2012	13:07:46	55	33.66688	15	39.54586	624		usbl	26/05/2012	23:52:53	55	33.60402	15	39.40555	577			ROV dive for multibeam mapping - no OFOP record	
Logachev1	JC073_058_SPI	148	27/05/2012	00:50:00	55	33.7105	15	38.4958	660		ship	27/05/2012	04:03:00	55	33.65	15	40.4	742			SPI transect with 5 sections	
	JC073_058_SPI/A	148	27/05/2012	00:50:00	55	33.7105	15	38.4958	660		ship	27/05/2012	01:40:00	55	33.7104	15	38.5				Section A: 5 dips	
	JC073_058_SPI/B	148	27/05/2012	01:55:00	55	33.7002	15	38.7898	660		ship	27/05/2012	02:15:00	55	33.7002	15	38.814				Section B: 5 dips	
	JC073_058_SPI/C	148	27/05/2012	02:22:00	55	33.6926	15	39.3979	671		ship	27/05/2012	02:39:00	55	33.6926	15	39.74				Section C: 3 dips	
	JC073_058_SPI/D	148	27/05/2012	03:03:00	55	33.6806	15	39.4081	587		ship	27/05/2012	03:10:00	55	33.68	15	39.4187				Section D: 3 dips	
	JC073_058_SPI/E	148	27/05/2012	03:45:00	55	33.6592	15	40.0381	744		ship	27/05/2012	04:03:00	55	33.65	15	40.04				Section E: 3 dips	
Logachev1	JC073_059_SPI	148	27/05/2012	05:00:00	55	34.141	15	40.7211	650		ship	27/05/2012	11:19:42	55	33.21917	15	38.80713	753.06			Failed - equipment error	
Logachev1	JC073_060_ROV12	148	27/05/2012	12:45:52	55	33.345942	15	39.337788	672		usbl	27/05/2012	15:21:02	55	33.41509	2	39.33516	566			Records are ROV on bottom and ROV leaves seabed	
	JC073_060_ROV12/BI0B07	148	27/05/2012	15:05:02	55	33.415092	15	39.33516			usbl										Cidaris	
	JC073_060_ROV12/BI0B07	148	27/05/2012	15:17:25	55	33.415092	15	39.33516			usbl											Lophelia
Logachev1	JC073_061_ROV13	148	27/05/2012	16:53:00	55	33.525888	15	39.314088	569		usbl	27/05/2012	20:02:35	55	33.57199	8	39.342438	563			Records are ROV on bottom and ROV leaves seabed	
	JC073_061_ROV13/BI0B01	148	27/05/2012	17:36:00	55	33.555702	15	39.338778			usbl											Lophelia fragments
	JC073_061_ROV13/BI0B02	148	27/05/2012	17:43:13	55	33.555102	15	39.340098			usbl											sponge
	JC073_061_ROV13/BI0B04	148	27/05/2012	17:57:21	55	33.55527	15	39.34092			usbl											Anemone
	JC073_061_ROV13/BI0B03	148	27/05/2012	18:06:13	55	33.555222	15	39.34122			usbl											urchin & coral fragment
	JC073_061_ROV13/BI0B01	148	27/05/2012	18:13:18	55	33.554928	15	39.340302			usbl											orange Lophelia
	JC073_061_ROV13/BI0B03	148	27/05/2012	18:22:03	55	33.555438	15	39.339469			usbl											hydroid & Lophelia
	JC073_061_ROV13/BI0B01	148	27/05/2012	18:25:20	55	33.55497	15	39.339882			usbl											urchin
	JC073_061_ROV13/BI0B03	148	27/05/2012	18:27:10	55	33.555222	15	39.340038			usbl											Madrepora
	JC073_061_ROV13/BI0B01	148	27/05/2012	18:29:56	55	33.554928	15	39.339642			usbl											CLOD card experiment 1
	JC073_061_ROV13/CLOD01	148	27/05/2012	18:39:46	55	33.55828	15	39.339612			usbl											CLOD card experiment 2
	JC073_061_ROV13/CLOD02	148	27/05/2012	19:08:32	55	33.56664	15	39.33144			usbl											
	JC073_061_ROV13/MBIO01	148	27/05/2012	19:34:29	55	33.571422	15	39.336462			usbl											
	JC073_061_ROV13/MBIO02	148	27/05/2012	19:47:59	55	33.571422	15	39.336162			usbl											
	JC073_061_ROV13/MBIO03	148	27/05/2012	19:52:46	55	33.57153	15	39.33564			usbl											
Logachev1	JC073_062_ROV14	148	27/05/2012	22:17:05	55	33.554172	15	39.361518	564		usbl	27/05/2012	23:05:06	55	33.56335	2	39.367632				dive for Eddy lander deployment	
	JC073_062_ROV14/EDDY	148	27/05/2012	22:53:19	55	33.560358	15	39.360312			usbl	29/05/2012	20:50:13	56	26.43585	16	-20.63418					
Logachev1	JC073_063_GC	149	28/05/2012	00:27:00	55	33.658	15	39.326	573		ship											Failed, small coral sample in bag. Pull-out: 1.93T
Logachev1	JC073_064_GC	149	28/05/2012	01:17:00	55	33.658	15	39.326	575		ship											Failed, substantial amount of live and dead coral on top of wing. Pull-out: 1.98T
Logachev1	JC073_065_GC	149	28/05/2012	02:25:00	55	33.32	15	39.3261	690		ship											Pull-out: 1.89, ca. 90cm recovery
Logachev1	JC073_066_GC	149	28/05/2012	03:33:00	55	33.32	15															

	JC073_068_CTDn19	149	28/05/2012	07:25:00	55	33.658	15	39.324	573	15	ship									
	JC073_068_CTDn22	149	28/05/2012	07:26:00	55	33.658	15	39.324	573	15	ship									
	JC073_068_CTDn23	149	28/05/2012	07:27:00	55	33.658	15	39.324	573	5	ship									
	JC073_068_CTDn24	149	28/05/2012	07:27:00	55	33.658	15	39.324	573	5	ship									
Logachev1	JC073_069_CTD	149	28/05/2012	08:53:00	55	33.658	15	39.324	573	565	ship									
	JC073_069_CTD/SAPS	149	28/05/2012	08:54:00	55	33.658	15	39.324	573	565	ship	28/05/2012	09:18:00	55	33.658	15	39.324	573	record is for CTD at bottom. This CTD may be station number 72 in rough log	
	JC073_069_CTDn01	149	28/05/2012	09:09:00	55	33.658	15	39.324	573	577	ship								24 min pumping	
	JC073_069_CTDn02	149	28/05/2012	09:09:00	55	33.658	15	39.324	573	577	ship									
	JC073_069_CTDn03	149	28/05/2012	09:23:00	55	33.658	15	39.324	573	497	ship									
	JC073_069_CTDn04	149	28/05/2012	09:24:00	55	33.658	15	39.324	573	497	ship									
	JC073_069_CTDn05	149	28/05/2012	09:34:00	55	33.658	15	39.324	573	252	ship									
	JC073_069_CTDn06	149	28/05/2012	09:34:00	55	33.658	15	39.324	573	252	ship									
	JC073_069_CTDn07	149	28/05/2012	09:40:00	55	33.658	15	39.324	573	130	ship									
	JC073_069_CTDn08	149	28/05/2012	09:40:00	55	33.658	15	39.324	573	130	ship									
	JC073_069_CTDn09	149	28/05/2012	09:48:00	55	33.658	15	39.324	573	95	ship									
	JC073_069_CTDn10	149	28/05/2012	09:48:00	55	33.658	15	39.324	573	95	ship									
	JC073_069_CTDn11	149	28/05/2012	09:48:00	55	33.658	15	39.324	573	95	ship									
	JC073_069_CTDn12	149	28/05/2012	09:49:00	55	33.658	15	39.324	573	95	ship									
	JC073_069_CTDn13	149	28/05/2012	09:49:00	55	33.658	15	39.324	573	95	ship									
	JC073_069_CTDn14	149	28/05/2012	09:49:00	55	33.658	15	39.324	573	96	ship									
	JC073_069_CTDn15	149	28/05/2012	09:49:00	55	33.658	15	39.324	573	96	ship									
	JC073_069_CTDn16	149	28/05/2012	09:50:00	55	33.658	15	39.324	573	95	ship									
	JC073_069_CTDn17	149	28/05/2012	09:55:00	55	33.658	15	39.324	573	25	ship									
	JC073_069_CTDn18	149	28/05/2012	09:55:00	55	33.658	15	39.324	573	25	ship									
	JC073_069_CTDn19	149	28/05/2012	09:57:00	55	33.658	15	39.324	573	15	ship									
	JC073_069_CTDn22	149	28/05/2012	09:59:00	55	33.658	15	39.324	573	11	ship									
	JC073_069_CTDn23	149	28/05/2012	10:00:00	55	33.658	15	39.324	573	2.4	ship									
	JC073_069_CTDn24	149	28/05/2012	10:00:00	55	33.658	15	39.324	573	2.3	ship									
Logachev1	JC073_073_CTD	149	28/05/2012	10:39:00	55	33.65839	15	39.32386	581		ship	28/05/2012	12:14:00	55	33.658	15	39.324	572	record is for CTD in water and on deck	
	JC073_073_CTD/SAPS	149	28/05/2012	11:15:00	55	33.658	15	39.324	572	562	ship	28/05/2012	11:39:00	55	33.658	15	39.324	572	24 min pumping	
	JC073_073_CTDn01	149	28/05/2012	11:18:00	55	33.658	15	39.324	572	568	ship									
	JC073_073_CTDn02	149	28/05/2012	11:18:00	55	33.658	15	39.324	572	568	ship									
	JC073_073_CTDn03	149	28/05/2012	11:43:00	55	33.658	15	39.324	572	500	ship									
	JC073_073_CTDn04	149	28/05/2012	11:43:00	55	33.658	15	39.324	572	500	ship									
	JC073_073_CTDn05	149	28/05/2012	11:52:00	55	33.658	15	39.324	572	300	ship									
	JC073_073_CTDn06	149	28/05/2012	11:52:00	55	33.658	15	39.324	572	300	ship									
	JC073_073_CTDn07	149	28/05/2012	11:59:00	55	33.658	15	39.324	572	130	ship									
	JC073_073_CTDn08	149	28/05/2012	12:00:00	55	33.658	15	39.324	572	130	ship									
	JC073_073_CTDn09	149	28/05/2012	12:00:00	55	33.658	15	39.324	572	130	ship									
	JC073_073_CTDn10	149	28/05/2012	12:00:00	55	33.658	15	39.324	572	130	ship									
	JC073_073_CTDn11	149	28/05/2012	12:01:00	55	33.658	15	39.324	572	130	ship									
	JC073_073_CTDn12	149	28/05/2012	12:01:00	55	33.658	15	39.324	572	130	ship									
	JC073_073_CTDn13	149	28/05/2012	12:02:00	55	33.658	15	39.324	572	130	ship									
	JC073_073_CTDn14	149	28/05/2012	12:02:00	55	33.658	15	39.324	572	130	ship									
	JC073_073_CTDn15	149	28/05/2012	12:06:00	55	33.658	15	39.324	572	70	ship									
	JC073_073_CTDn16	149	28/05/2012	12:06:00	55	33.658	15	39.324	572	70	ship									
	JC073_073_CTDn17	149	28/05/2012	12:09:00	55	33.658	15	39.324	572	25	ship									
	JC073_073_CTDn18	149	28/05/2012	12:10:00	55	33.658	15	39.324	572	25	ship									
	JC073_073_CTDn19	149	28/05/2012	12:11:00	55	33.658	15	39.324	572	15	ship									
	JC073_073_CTDn22	149	28/05/2012	12:11:00	55	33.658	15	39.324	572	16	ship									
	JC073_073_CTDn23	149	28/05/2012	12:14:00	55	33.658	15	39.324	572	2	ship									
	JC073_073_CTDn24	149	28/05/2012	12:14:00	55	33.658	15	39.324	572	2.3	ship									
Logachev1	JC073_074_ROV15	149	28/05/2012	13:29:44	55	32.8401	15	37.876272	872		usbl	28/05/2012	15:03:41	55	32.85886	2	15	37.88691	867	Dive aborted to redesign spreader experiments
Logachev1	JC073_075_ROV16	149	28/05/2012	16:40:35	55	32.83449	15	37.876212	872		usbl	28/05/2012	18:36:47	55	33.06492	15	38.00448	744	record is for arrival and leaving seabed	
	JC073_075_ROV16/BI0B01	149	28/05/2012	17:03:30	55	32.87103	15	37.89912			usbl								sponge	
	JC073_075_ROV16/BI0B02	149	28/05/2012	17:13:17	55	32.87037	15	37.90101			usbl								sponge	
	JC073_075_ROV16/BI0B03	149	28/05/2012	17:14:51	55	32.87034	15	37.900932			usbl								sponge	
	JC073_075_ROV16/BI0B04	149	28/05/2012	17:33:09	55	32.88738	15	37.912902			usbl								sponge	
	JC073_075_ROV16/BI0B05	149	28/05/2012	17:36:55	55	32.888142	15	37.912848			usbl								sponge	
	JC073_075_ROV16/SUC	149	28/05/2012	18:25:52	55	32.95872	15	37.951242			usbl								Anthomastus slurped	
	JC073_075_ROV16/BI0B04	149	28/05/2012	18:26:08	55	32.959068	15	37.951068			usbl								two colonies of Madrepora	
	JC073_075_ROV16/BI0B04	149	28/05/2012	18:31:17	55	32.96001	15	37.951548			usbl								Madrepora	
	JC073_075_ROV16/BI0B04	149	28/05/2012	18:35:17	55	32.959452	15	37.949082			usbl								Madrepora	
	JC073_075_ROV16/BI0B04	149	28/05/2012	18:39:01	55	32.960628	15	37.94964			usbl								Madrepora	
	JC073_075_ROV16/BI0B04	149	28/05/2012	18:44:26	55	32.95908	15	37.950378			usbl								Madrepora	
	JC073_075_ROV16/MBI001	149	28/05/2012	19:31:02	55	33.06633	15	38.00709			usbl								white Lophelia	
	JC073_075_ROV16/MBI002	149	28/05/2012	19:39:12	55	33.06492	15	38.00448			usbl								white Lophelia	
	JC073_075_ROV16/MBI003	149	28/05/2012	19:43:53	55	33.06492	15	38.00448			usbl								white Lophelia	
Logachev1	JC073_076_ROV17	149	28/05/2012	22:07:40	55															

	JC073_087_CTDh05	150	29/05/2012	11:58:00	55	33.547	15	38.746	590	150	ship										
	JC073_087_CTDh06	150	29/05/2012	11:59:00	55	33.548	15	38.746	590	150	ship										
	JC073_087_CTDh07	150	29/05/2012	11:59:00	55	33.549	15	38.746	590	150	ship										
	JC073_087_CTDh08	150	29/05/2012	12:00:00	55	33.55	15	38.746	590	150	ship										
	JC073_087_CTDh09	150	29/05/2012	12:00:00	55	33.551	15	38.746	590	150	ship										
	JC073_087_CTDh10	150	29/05/2012	12:00:00	55	33.552	15	38.746	590	150	ship										
	JC073_087_CTDh11	150	29/05/2012	12:01:00	55	33.553	15	38.746	590	150	ship										
	JC073_087_CTDh12	150	29/05/2012	12:01:00	55	33.554	15	38.746	590	150	ship										
	JC073_087_CTDh13	150	29/05/2012	12:02:00	55	33.555	15	38.746	590	150	ship										
	JC073_087_CTDh14	150	29/05/2012	12:02:00	55	33.556	15	38.746	590	150	ship										
	JC073_087_CTDh15	150	29/05/2012	12:03:00	55	33.557	15	38.746	590	150	ship										
	JC073_087_CTDh16	150	29/05/2012	12:03:00	55	33.558	15	38.746	590	150	ship										
	JC073_087_CTDh17	150	29/05/2012	12:08:00	55	33.559	15	38.746	590	70	ship										
	JC073_087_CTDh18	150	29/05/2012	12:08:00	55	33.56	15	38.746	590	70	ship										
	JC073_087_CTDh19	150	29/05/2012	12:12:00	55	33.561	15	38.746	590	25	ship										
	JC073_087_CTDh20	150	29/05/2012	12:14:00	55	33.562	15	38.746	590	25	ship										
	JC073_087_CTDh21	150	29/05/2012	12:15:00	55	33.563	15	38.746	590	15	ship										
	JC073_087_CTDh22	150	29/05/2012	12:17:00	55	33.564	15	38.746	590	15	ship										
	JC073_087_CTDh23	150	29/05/2012	12:17:00	55	33.565	15	38.746	590	5	ship										
	JC073_087_CTDh24	150	29/05/2012	12:18:00	55	33.566	15	38.746	590	5	ship										
Logachev1	JC073_088_CTD	150	29/05/2012	12:50:00	55	33.54341	15	38.74296	589		ship	29/05/2012	13:28:00	55	33.54262	15	38.74354	589		Deep-water pump for aquaria	
	JC073_088_CTD/DWP	150	29/05/2012	12:55:00	55	33.54341	15	38.74296	589		ship	29/05/2012	13:28:00	55	33.54262	15	38.74354	589			
Logachev1	JC073_089_BC	150	29/05/2012	13:58:00	55	33.54402	15	38.74239	590		ship										Failed - did not trigger
Logachev1	JC073_090_BC	150	29/05/2012	14:43:00	55	33.54358	15	38.74266	590		ship										Failed - did not trigger
Logachev1	JC073_091_BC	150	29/05/2012	15:45:00	55	33.268	15	38.057	660		ship										good recovery
Logachev1	JC073_092_BC	150	29/05/2012	17:30:00	55	33.268	15	38.057	660		ship										good recovery
Logachev1	JC073_093_ROV19	150	29/05/2012	19:27:33	55	33.56346	15	39.392352	559		usbl	29/05/2012	20:57:40	55	33.56479	2	39.36477	561		record for ROV on/off seabed Eddy recovery_JC073_062_ROV14/EDDY	
Logachev1	JC073_094_MVP	150	29/05/2012	22:05:00	55	32.53657	15	38.77198	814		ship	30/05/2012	10:55:41	55	29.59472	15	38.80161				
Logachev2	JC073_095_ROV19	151	30/05/2012	12:12:38	55	29.656548	15	49.65078	844		usbl	30/05/2012	19:15:28	55	29.70682	8	48.247518	559		record is for ROV on and off seabed.	
	JC073_095_ROV19/BIOB01	151	30/05/2012	13:48:44	55	29.654142	15	49.326708			usbl										sponge
	JC073_095_ROV19/BIOB02	151	30/05/2012	14:03:04	55	29.654322	15	49.29162			usbl										sponge
	JC073_095_ROV19/BIOB05	151	30/05/2012	14:13:14	55	29.654742	15	49.29246			usbl										Madrepora and crinoid
	JC073_095_ROV19/BIOB03	151	30/05/2012	14:30:23	55	29.65836	15	49.212168			usbl										sponge
	JC073_095_ROV19/BIOB04	151	30/05/2012	14:34:00	55	29.658342	15	49.21236			usbl										sponge
	JC073_095_ROV19/MBIO01	151	30/05/2012	14:57:13	55	29.65761	15	49.126302			usbl										coral for microbiology
	JC073_095_ROV19/MBIO02	151	30/05/2012	15:03:32	55	29.657292	15	49.12641			usbl										coral for microbiology
	JC073_095_ROV19/MBIO03	151	30/05/2012	15:09:57	55	29.65764	15	49.125018			usbl										coral for microbiology
	JC073_095_ROV19/BIOB04	151	30/05/2012	15:22:00	55	29.656518	15	49.11615			usbl										sponge
	JC073_095_ROV19/BIOB05	151	30/05/2012	15:26:20	55	29.65548	15	49.11657			usbl										sponge
	JC073_095_ROV19/BIOB01	151	30/05/2012	15:24:00	55	29.65563	15	49.11369			usbl										sponge
	JC073_095_ROV19/BIOB01	151	30/05/2012	15:27:25	55	29.655282	15	49.11555			usbl										sponge
	JC073_095_ROV19/BIOB05	151	30/05/2012	16:36:20	55	29.687772	15	48.71343			usbl										Lophelia
	JC073_095_ROV19/BIOB06	151	30/05/2012	16:43:02	55	29.688822	15	48.711702			usbl										coral
	JC073_095_ROV19/BIOB07	151	30/05/2012	16:47:28	55	29.688432	15	48.710658			usbl										coral
	JC073_095_ROV19/BIOB08	151	30/05/2012	16:53:15	55	29.68758	15	48.71163			usbl										coral
	JC073_095_ROV19/MBIO04	151	30/05/2012	17:03:47	55	29.689788	15	48.711612			usbl										
	JC073_095_ROV19/MBIO05	151	30/05/2012	17:10:37	55	29.68917	15	48.712248			usbl										
	JC073_095_ROV19/MBIO06	151	30/05/2012	17:16:00	55	29.688678	15	48.71235			usbl										
	JC073_095_ROV19/BIOB03	151	30/05/2012	18:41:46	55	29.705502	15	48.411648			usbl										sponge
Logachev2	JC073_096_ROV20	151	30/05/2012	21:20:45	55	30.735318	15	45.867552	874		usbl	30/05/2012	23:47:43	55	30.31504	2	46.312518	591		record is for ROV on and off seabed	
Logachev1	JC073_097_SPI	152	31/05/2012	01:24:26	55	33.75282	15	36.97949	727.72		ship	31/05/2012	11:05:34	55	34.00677	15	40.22334	706.45		SPI transect with 14 sections	
	JC073_097_SPI/A	152	31/05/2012	01:46:00	55	33.7532	15	36.9802	727		ship	31/05/2012	02:00:00	55	33.7328	15	36.9658				Section A: 5 dips
	JC073_097_SPI/B	152	31/05/2012	02:30:00	55	33.5793	15	36.85	720		usbl	31/05/2012	02:48:00	55	33.5568	15	36.8413				Section B: 5 dips
	JC073_097_SPI/C	152	31/05/2012	03:05:00	55	33.4078	15	36.7331	776		usbl	31/05/2012	03:10:00	55	33.4028	15	36.7299				Section C: 2 dips
	JC073_097_SPI/D	152	31/05/2012	03:36:00	55	33.1612	15	36.3855	897		usbl	31/05/2012	03:50:00	55	33.14764	15	36.3733				Section D: 5 dips
	JC073_097_SPI/E	152	31/05/2012	04:25:00	55	33.1143	15	36.53208	896		usbl	31/05/2012	04:45:00	55	33.7152	15	36.3192				Section E: 4 dips
	JC073_097_SPI/F	152	31/05/2012	05:27:00	55	33.1437	15	37.3287	747		usbl	31/05/2012	05:39:00	55	33.8845	15	37.2055				Section F: 4 dips
	JC073_097_SPI/G	152	31/05/2012	05:55:00	55	33.15468	15	37.53738	752		usbl	31/05/2012	06:10:00	55	33.8531	15	37.3958				Section G: 4 dips
	JC073_097_SPI/H	152	31/05/2012	06:35:00	55	33.15396	15	38.06286	704		usbl	31/05/2012	06:48:00	55	33.7532	15	38.1331				Section H: 4 dips
	JC073_097_SPI/I	152	31/05/2012	07:11:00	55	33.22344	15	38.58312	710		usbl	31/05/2012	07:24:00	55	33.1339	15	38.4				Section I: 5 dips
	JC073_097_SPI/J	152	31/05/2012	07:55:00	55	33.24156	15	39.20934	755		usbl	31/05/2012	08:20:00	55	33.1366	15	39.18				Section J: 5 dips
	JC073_097_SPI/K	152	31/05/2012	08:50:00	55	33.1508	15	39.57	765		usbl	31/05/2012	09:05:00	55	33.14921	15	39.5984				Section K: 5 dips
	JC073_097_SPI/L	152	31/05/2012	09:25:00	55	33.2186	15	40.93	780		usbl	31/05/2012	09:35:00	55	33.2288	15	40.4065				Section L: 4 dips
	JC073_097_SPI/M	152	31/05/2012	10:01:00	55	33.6882	15	40.1578	750		usbl	31/05/2012	10:09:00	55	33.42	15	40.1086				Section M: 4 dips
	JC073_097_SPI/N	152	31/05/2012	10:27:00	55	33.57	15	40.1262	705		usbl	31/05/2012	10:33:00	55	33.5979	15	40.1336				Section N: 3 dips
Logachev1	JC073_098_CTD	152	31/05/2012	11:31:00	55	33.18926	15	39.18996	801		ship	31/05/2012	12:38:00	55	33.194	15	39.193	818		record for CTD in water and on deck	
	JC073_098_CTDh01	152	31/05/2012	11:58:00	55	33.18878	15	39.18976	820	805	ship										
	JC073_098_CTDh02	152	31/05/2012	11:59:00	55	33.18878	15	39.18976	820	805	ship										
	JC073_098_CTDh03	152	31/05/2012	11:59:00	55	33.18878	15	39.18976	820	805	ship										
	JC073_098_CTDh04	152	31/05/2012	12:00																	

	JC073_098_CTDn20	152	31/05/2012	12:13:00	55	33.18878	15	39.18976	820	700	ship													
	JC073_098_CTDn21	152	31/05/2012	12:14:00	55	33.18878	15	39.18976	820	700	ship													
	JC073_098_CTDn22	152	31/05/2012	12:18:00	55	33.18878	15	39.18976	820	600	ship													
	JC073_098_CTDn23	152	31/05/2012	12:19:00	55	33.18878	15	39.18976	820	600	ship													
	JC073_098_CTDn24	152	31/05/2012	12:37:00	55	33.18878	15	39.18976	820	3	ship													
Logachev1	JC073_099_ROV	152	31/05/2012	14:17:33	55	33.218862	15	39.164838	775		usbl	31/05/2012	15:16:12	55	2	33.22666	15	39.16011					records for ROV on and off seabed. Dive for Eddy deployment	
	JC073_099_ROV/EDDY	152	31/05/2012	14:43:04	55	33.22773	15	39.142248			usbl	04/06/2012	13:20:52	55		33.22206	15	39.145182					Eddy lander deployed & recovered on Dive 24	
Logachev1	JC073_100_ROV	152	31/05/2012	16:40:42	55	33.906378	15	39.160668			ship	31/05/2012	16:57:44	55	8		15	39.160668					record for ROV in water & on deck. Dive aborted-ship propeller malfunctioning	
Logachev1	JC073_101_CTD	152	31/05/2012	19:34:00	55	33.863	15	39.233	676		ship	31/05/2012	20:23:00	55		33.863	15	39.233					DCTD for pumping	
	JC073_101_CTD/DWP	152	31/05/2012	19:34:00	55	33.863	15	39.233	676		ship	31/05/2012	20:23:00	55		33.863	15	39.233						
Logachev1	JC073_102_ROV	152	31/05/2012	21:25:47	55	33.512838	15	39.381108	566		usbl	31/05/2012	23:33:23	55		33.58494	15	39.355992					record is for ROV on or off bottom	
	JC073_102_ROV/BIOB01	152	31/05/2012	21:54:41	55	33.555288	15	39.338502			usbl												coral fragments for CLOD card 1	
	JC073_102_ROV/BIOB02	152	31/05/2012	21:59:51	55	33.554748	15	39.338292			usbl												anemone and urchin	
	JC073_102_ROV/BIOB03	152	31/05/2012	22:04:00	55	33.555348	15	39.339552			usbl												anemone, sponge and coral	
	JC073_102_ROV/BIOB04	152	31/05/2012	22:07:00	55	33.555678	15	39.338982			usbl												sponge, madrepora	
	JC073_102_ROV/BIOB05	152	31/05/2012	22:11:00	55	33.555132	15	39.338982			usbl												anemone, coral	
	JC073_102_ROV/BIOB06	152	31/05/2012	22:25:00	55	33.566418	15	39.331812			usbl												Lophelia	
	JC073_102_ROV/BIOB07	152	31/05/2012	22:30:00	55	33.56715	15	39.33225			usbl												anemone	
	JC073_102_ROV/BIOB08	152	31/05/2012	22:33:00	55	33.566772	15	39.331992			usbl												coral	
	JC073_102_ROV/BIOB09	152	31/05/2012	22:45:00	55	33.56757	15	39.332412			usbl												sponge	
	JC073_102_ROV/BIOB05	152	31/05/2012	22:54:00	55	33.5482014	15	39.3100056			usbl												urchin	
Logachev2	JC073_103_BC	153	01/06/2012	02:04:43	55	29.63213	15	51.52631	884		ship												failed	
Logachev2	JC073_104_BC	153	01/06/2012	03:24:43	55	29.63249	15	51.52474	884		ship												failed	
Logachev2	JC073_105_BC	153	01/06/2012	04:35:12	55	29.632	15	51.52609	883		ship												failed	
Logachev2	JC073_106_BC	153	01/06/2012	06:04:59	55	29.58139	15	49.18974	695		ship												small sample, mainly coral fragments	
Logachev2	JC073_107_BC	153	01/06/2012	07:01:39	55	29.57993	15	49.18957	694		ship												good recovery	
Logachev2	JC073_108_BC	153	01/06/2012	07:57:29	55	29.58209	15	49.19118	697		ship												failed due to winch issues	
Logachev2	JC073_109_BC	153	01/06/2012	08:58:22	55	29.58065	15	49.18958	706		ship												failed, didn't fire	
Logachev2	JC073_110_BC	153	01/06/2012	09:57:51	55	29.58076	15	49.19228	698		ship												very small recovery	
Logachev2	JC073_111_CTD	153	01/06/2012	11:12:00	55	28.934	15	47.618	923		ship	01/06/2012	12:24:00	55		29.089	15	47.726					records are CTD in water and on deck	
	JC073_111_CTDn01	153	01/06/2012	11:45:00	55	28.933	15	47.614	928	912	ship													
	JC073_111_CTDn02	153	01/06/2012	11:45:00	55	28.933	15	47.614	928	912	ship													
	JC073_111_CTDn03	153	01/06/2012	11:52:00	55	28.933	15	47.614	928	795	ship													
	JC073_111_CTDn04	153	01/06/2012	11:52:00	55	28.933	15	47.614	928	795	ship													
	JC073_111_CTDn05	153	01/06/2012	11:56:00	55	28.933	15	47.614	928	700	ship													
	JC073_111_CTDn06	153	01/06/2012	11:56:00	55	28.933	15	47.614	928	700	ship													
	JC073_111_CTDn07	153	01/06/2012	12:00:00	55	28.933	15	47.614	928	800	ship													
	JC073_111_CTDn08	153	01/06/2012	12:01:00	55	28.933	15	47.614	928	600	ship													
	JC073_111_CTDn09	153	01/06/2012	12:01:00	55	28.933	15	47.614	928	600	ship													
	JC073_111_CTDn10	153	01/06/2012	12:01:00	55	28.933	15	47.614	928	600	ship													
	JC073_111_CTDn11	153	01/06/2012	12:01:00	55	28.933	15	47.614	928	600	ship													
	JC073_111_CTDn12	153	01/06/2012	12:01:00	55	28.933	15	47.614	928	600	ship													
	JC073_111_CTDn13	153	01/06/2012	12:02:00	55	28.933	15	47.614	928	600	ship													
	JC073_111_CTDn14	153	01/06/2012	12:02:00	55	28.933	15	47.614	928	600	ship													
	JC073_111_CTDn15	153	01/06/2012	12:02:00	55	28.933	15	47.614	928	600	ship													
	JC073_111_CTDn16	153	01/06/2012	12:02:00	55	28.933	15	47.614	928	600	ship													
	JC073_111_CTDn17	153	01/06/2012	12:02:00	55	28.933	15	47.614	928	600	ship													
	JC073_111_CTDn18	153	01/06/2012	12:03:00	55	28.933	15	47.614	928	600	ship													
	JC073_111_CTDn19	153	01/06/2012	12:03:00	55	28.933	15	47.614	928	600	ship													
	JC073_111_CTDn20	153	01/06/2012	12:03:00	55	28.933	15	47.614	928	600	ship													
	JC073_111_CTDn21	153	01/06/2012	12:03:00	55	28.933	15	47.614	928	600	ship													
	JC073_111_CTDn22	153	01/06/2012	12:03:00	55	28.933	15	47.614	928	600	ship													
	JC073_111_CTDn23	153	01/06/2012	12:04:00	55	28.933	15	47.614	928	600	ship													
	JC073_111_CTDn24	153	01/06/2012	12:04:00	55	28.933	15	47.614	928	600	ship													
Logachev2	JC073_112 MVP	153	01/06/2012	13:00:00	55	29.0917	15	47.72064	867		ship													
Logachev2	JC073_113_MBES	154	02/06/2012	12:28:00	55	35.894	15	33.825			ship	03/06/2012	09:57:00	55		29.088	15	56.078					812	multibeam and SBP survey to cover bad weather period
	JC073_113_MBES/SBP	154	02/06/2012	12:28:00	55	35.894	15	33.825			ship	03/06/2012	09:57:00	55		29.088	15	56.078					812	
Logachev2	JC073_114_CTD	155	03/06/2012	11:17:00	55	29.153	15	48.012	770		ship	03/06/2012	12:48:00	55		29.156	15	48.015					763	CTD records for in water and on deck
	JC073_114_CTD/SAPS	155	03/06/2012	11:56:00	55	29.155	15	48.019	770	600	ship	03/06/2012	12:20:00	55		29.155	15	48.019					770	24 min pumping
	JC073_114_CTDn01	155	03/06/2012	12:00:00	55	29.155	15	48.019	770	600	ship													

	JC073_141_ROV28/BIOB06	158	06/06/2012	15:13:47	55	33.668298	15	39.328398		usbl								orange Lophelia	
	JC073_141_ROV28/BIOB05	158	06/06/2012	15:15:50	55	33.668748	15	39.327918		usbl								orange Lophelia	
	JC073_141_ROV28/MBIO04	158	06/06/2012	15:21:17	55	33.668598	15	39.3282		usbl									
	JC073_141_ROV28/MBIO05	158	06/06/2012	15:24:05	55	33.66879	15	39.328248		usbl									
	JC073_141_ROV28/MBIO06	158	06/06/2012	15:26:35	55	33.668862	15	39.328878		usbl									
	JC073_141_ROV28/BIOB07	158	06/06/2012	15:31:16	55	33.66828	15	39.327648		usbl									
Logachev1	JC073_142_ROV29	158	06/06/2012	18:14:07	55	33.69447	15	39.551292	640	usbl	06/06/2012	18:29:04	55	33.69786	15	39.515712		Dive cancelled due to weather	
Pisces9	JC073_143_SVP	159	07/06/2012	06:45:07	57	21.48509	14	43.07298	307	ship	07/06/2012	07:12:28	57	21.48417	14	43.07115	303		
Pisces9	JC073_144_MBES	159	07/06/2012	07:33:46	57	20.71958	14	43.93508	314	ship	07/06/2012	10:28:00	57	37.25377	14	28.98103	261	Swath survey and simultaneous MVP survey	
	JC073_144_MBES/7/10	159	07/06/2012	07:33:46	57	20.71958	14	43.93508	314	ship	07/06/2012	10:28:00	57	37.25377	14	28.98103	261		
	JC073_144_MBES/SBP	159	07/06/2012	07:33:46	57	20.71958	14	43.93508	314	ship	07/06/2012	10:28:00	57	37.25377	14	28.98103	261		
	JC073_144_MBES/MVP	159	07/06/2012	07:33:46	57	20.71958	14	43.93508	314	ship	07/06/2012	10:28:00	57	37.25377	14	28.98103	261		
Pisces9	JC073_145_ROV30	159	07/06/2012	11:13:30	57	36.50232	14	29.50992	259	usbl	07/06/2012	12:21:10	57	36.60031	8	55.5502085	259	records for ROV on & off bottom. Dive ended early, slurp gun stuck in thruster	
	JC073_145_ROV30/BIOB02	159	07/06/2012	11:43:30	57	36.59877	14	29.545092		usbl								white Lophelia	
	JC073_145_ROV30/BIOB01	159	07/06/2012	11:47:01	57	36.59853	14	29.545758		usbl								lophelia framework	
Pisces9	JC073_146_ROV31	159	07/06/2012	14:00:37	57	36.599832	14	29.54655	258	usbl	07/06/2012	18:19:26	57	36.34966	2	55.5502085	263	records for ROV on and off bottom.	
	JC073_146_ROV31/BIOB05	159	07/06/2012	14:22:43	57	36.58815	14	29.518008		usbl								live lophelia	
	JC073_146_ROV31/BIOB05	159	07/06/2012	14:24:41	57	36.588312	14	29.518512		usbl								live lophelia	
	JC073_146_ROV31/BIOB05	159	07/06/2012	14:35:09	57	36.587832	14	29.517372		usbl								live lophelia	
	JC073_146_ROV31/BIOB05	159	07/06/2012	14:36:09	57	36.588138	14	29.51703		usbl								live lophelia	
	JC073_146_ROV31/BIOB06	159	07/06/2012	15:52:51	57	36.540288	14	29.467308		usbl								live lophelia	
	JC073_146_ROV31/BIOB06	159	07/06/2012	15:56:26	57	36.540312	14	29.467218		usbl								live lophelia	
	JC073_146_ROV31/BIOB06	159	07/06/2012	15:59:54	57	36.539868	14	29.467488		usbl								live lophelia	
	JC073_146_ROV31/BIOB06	159	07/06/2012	16:01:59	57	36.540582	14	29.467638		usbl								live lophelia	
	JC073_146_ROV31/BIOB06	159	07/06/2012	16:06:15	57	36.540522	14	29.466978		usbl								live lophelia	
	JC073_146_ROV31/BIOB07	159	07/06/2012	16:37:45	57	36.527988	14	29.413332		usbl								live lophelia	
	JC073_146_ROV31/BIOB07	159	07/06/2012	16:40:18	57	36.527712	14	29.41401		usbl								live lophelia	
	JC073_146_ROV31/BIOB07	159	07/06/2012	16:42:15	57	36.527532	14	29.413842		usbl								live lophelia	
	JC073_146_ROV31/SUC	159	07/06/2012	16:47:12	57	36.52839	14	29.41398		usbl								sebastes	
	JC073_146_ROV31/BIOB01	159	07/06/2012	17:41:22	57	36.343872	14	29.621598		usbl								black coral	
Pisces9	JC073_147_ROV32	159	07/06/2012	19:42:48	57	35.698542	14	30.757632		usbl	07/06/2012	23:52:27	57	35.69133	14	55.5502085		records for ROV on bottom and on deck	
	JC073_147_ROV32/MBIO01	159	07/06/2012	20:14:30	57	35.63445	14	30.72528		usbl								lophelia for microbio, actual sampling moment was not recorded	
	JC073_147_ROV32/MBIO02	159	07/06/2012	20:28:42	57	35.634162	14	30.726222		usbl								lophelia for microbio, actual sampling moment was not recorded	
	JC073_147_ROV32/MBIO03	159	07/06/2012	20:32:36	57	35.634108	14	30.72483		usbl								lophelia for microbio, actual sampling moment was not recorded	
	JC073_147_ROV32/MBIO04	159	07/06/2012	21:08:43	57	35.56317	14	30.683412		usbl								lophelia	
	JC073_147_ROV32/MBIO05	159	07/06/2012	21:20:20	57	35.56227	14	30.68274		usbl								lophelia	
	JC073_147_ROV32/MBIO06	159	07/06/2012	21:22:53	57	35.562798	14	30.683622		usbl								lophelia	
	JC073_147_ROV32/BIOB05	159	07/06/2012	21:26:34	57	35.562672	14	30.683172		usbl								live lophelia	
	JC073_147_ROV32/BIOB05	159	07/06/2012	21:30:00	57	35.562672	14	30.683172		usbl								live lophelia	
	JC073_147_ROV32/BIOB05	159	07/06/2012	21:32:35	57	35.562888	14	30.683862		usbl								live lophelia	
	JC073_147_ROV32/BIOB05	159	07/06/2012	21:35:30	57	35.562678	14	30.683532		usbl								live lophelia	
	JC073_147_ROV32/BIOB06	159	07/06/2012	22:40:40	57	35.67285	14	30.582342		usbl								live lophelia	
	JC073_147_ROV32/BIOB06	159	07/06/2012	22:42:40	57	35.672958	14	30.58185		usbl								live lophelia	
	JC073_147_ROV32/BIOB06	159	07/06/2012	22:44:59	57	35.673078	14	30.582138		usbl								live lophelia	
	JC073_147_ROV32/BIOB06	159	07/06/2012	22:46:37	57	35.673102	14	30.582438		usbl								live lophelia	
	JC073_147_ROV32/BIOB07	159	07/06/2012	23:07:52	57	35.687322	14	30.577182		usbl								lophelia	
	JC073_147_ROV32/BIOB07	159	07/06/2012	23:12:33	57	35.6871	14	30.576642		usbl								lophelia	
	JC073_147_ROV32/BIOB01	159	07/06/2012	23:31:45	57	35.686992	14	30.565572		usbl								sponge	
	JC073_147_ROV32/BIOB01	159	07/06/2012	23:35:00	57	35.686992	14	30.565572		usbl								sponge, no record in ofop so used last position	
	JC073_147_ROV32/BIOB01	159	07/06/2012	23:39:00	57	35.686992	14	30.565572		usbl								asteroid, no record in ofop so used last position	
	JC073_147_ROV32/BIOB01	159	07/06/2012	23:40:00	57	35.686992	14	30.565572		usbl								urchin, no record in ofop so used last position	
NW Rockall Bank	JC073_148_MBES	160	08/06/2012	00:15:00	57	36.09651	14	30.26385	263	ship	08/06/2012	08:58:00	57	57.62245	13	58.75179	218	multibeam and MVP survey from Pisces9 site to MSS3	
	JC073_148_MBES/7/10	160	08/06/2012	00:15:00	57	36.09651	14	30.26385	263	ship	08/06/2012	08:58:00	57	57.62245	13	58.75179	218	(NW Rockall Bank protected area - JC060 Autosub sidescan patch)	
	JC073_148_MBES/SBP	160	08/06/2012	00:15:00	57	36.09651	14	30.26385	263	ship	08/06/2012	08:58:00	57	57.62245	13	58.75179	218		
	JC073_148_MBES/MVP	160	08/06/2012	00:15:00	57	36.09651	14	30.26385	263	ship	08/06/2012	08:58:00	57	57.62245	13	58.75179	218		
NW Rockall Bank	JC073_149_CTD	160	08/06/2012	09:28:00	57	57.527	13	59.456	221	216	ship	08/06/2012	10:13:00	57	57.527	13	59.457	221	CTD records for in water and on deck
	JC073_149_CTDh01	160	08/06/2012	09:43:00	57	57.527	13	59.46	222	217	ship								
	JC073_149_CTDh02	160	08/06/2012	09:43:00	57	57.527	13	59.46	222	217	ship								
	JC073_149_CTDh03	160	08/06/2012	09:43:00	57	57.527	13	59.46	222	217	ship								
	JC073_149_CTDh04	160	08/06/2012	09:44:00	57	57.527	13	59.46	222	217	ship								
	JC073_149_CTDh05	160	08/06/2012	09:44:00	57	57.527	13	59.46	222	217	ship								
	JC073_149_CTDh06	160	08/06/2012	09:45:00	57	57.527	13	59.46	222	217	ship								
	JC073_149_CTDh07	160	08/06/2012	09:45:00	57	57.527	13	59.46	222	217	ship								
	JC073_149_CTDh08	160	08/06/2012	09:46:00	57	57.527	13	59.46	222	217	ship								
	JC073_149_CTDh09	160	08/06/2012	09:46:00	57	57.527	13	59.46	222	217	ship								
	JC073_149_CTDh10	160	08/06/2012	09:47:00	57	57.527	13	59.46	222	217	ship								
	JC07																		

NW Rockall Bank	JC073_150_ROV33/BI0B01	160	08/06/2012	12:21:29	57	57.716118	13	59.588538		usbl								coral framework
	JC073_151_ROV34	160	08/06/2012	15:15:44	57	58.23303	13	61.293198	228	usbl	08/06/2012	16:29:59	57	58.34590	13	61.432248	230	
	JC073_151_ROV34/MBIO01	160	08/06/2012	16:02:26	57	58.319838	13	61.39275		usbl								Lophelia
	JC073_151_ROV34/MBIO02	160	08/06/2012	16:04:50	57	58.320288	13	61.393908		usbl								Lophelia
	JC073_151_ROV34/MBIO03	160	08/06/2012	16:08:39	57	58.32024	13	61.392828		usbl								Lophelia
Hebrides	JC073_152_CTD	161	09/06/2012	06:33:00	56	34.822	10	18.784	1922	40	09/06/2012	07:14:00	56	34.822	10	18.791	1921	CTD for deep-water pump
	JC073_152_CTD/DWP	161	09/06/2012	06:33:00	56	34.822	10	18.784	1922	40	09/06/2012	07:14:00	56	34.822	10	18.791	1921	
Hebrides	JC073_153_CTD	161	09/06/2012	07:32:00	56	34.835	10	18.745	1953	1942	09/06/2012	09:42:00	56	35.295	10	19.65	1959	
	JC073_153_CTD/h01	161	09/06/2012	08:41:00	56	35.2	10	19.462	1953	1930								
	JC073_153_CTD/h02	161	09/06/2012	08:42:00	56	35.2	10	19.462	1953	1930								
	JC073_153_CTD/h03	161	09/06/2012	08:56:00	56	35.2	10	19.462	1953	1500								
	JC073_153_CTD/h04	161	09/06/2012	08:56:00	56	35.2	10	19.462	1953	1500								
	JC073_153_CTD/h05	161	09/06/2012	09:07:00	56	35.2	10	19.462	1953	1000								
	JC073_153_CTD/h06	161	09/06/2012	09:07:00	56	35.2	10	19.462	1953	1000								
	JC073_153_CTD/h07	161	09/06/2012	09:18:00	56	35.2	10	19.462	1953	500								
	JC073_153_CTD/h08	161	09/06/2012	09:18:00	56	35.2	10	19.462	1953	500								
	JC073_153_CTD/h09	161	09/06/2012	09:27:00	56	35.2	10	19.462	1953	250								
	JC073_153_CTD/h10	161	09/06/2012	09:27:00	56	35.2	10	19.462	1953	250								
	JC073_153_CTD/h11	161	09/06/2012	09:28:00	56	35.2	10	19.462	1953	250								
	JC073_153_CTD/h12	161	09/06/2012	09:28:00	56	35.2	10	19.462	1953	250								
	JC073_153_CTD/h13	161	09/06/2012	09:28:00	56	35.2	10	19.462	1953	250								
	JC073_153_CTD/h14	161	09/06/2012	09:28:00	56	35.2	10	19.462	1953	250								
	JC073_153_CTD/h15	161	09/06/2012	09:28:00	56	35.2	10	19.462	1953	250								
	JC073_153_CTD/h16	161	09/06/2012	09:29:00	56	35.2	10	19.462	1953	250								
	JC073_153_CTD/h17	161	09/06/2012	09:29:00	56	35.2	10	19.462	1953	250								
	JC073_153_CTD/h18	161	09/06/2012	09:29:00	56	35.2	10	19.462	1953	250								
	JC073_153_CTD/h19	161	09/06/2012	09:29:00	56	35.2	10	19.462	1953	250								
	JC073_153_CTD/h20	161	09/06/2012	09:29:00	56	35.2	10	19.462	1953	250								
	JC073_153_CTD/h21	161	09/06/2012	09:39:00	56	35.2	10	19.462	1953	50								
	JC073_153_CTD/h22	161	09/06/2012	09:39:00	56	35.2	10	19.462	1953	50								
	JC073_153_CTD/h23	161	09/06/2012	09:41:00	56	35.2	10	19.462	1953	10								
	JC073_153_CTD/h24	161	09/06/2012	09:41:00	56	35.2	10	19.462	1953	10								
Hebrides	JC073_154_BC	161	09/06/2012	12:04:00	56	30.87621	9	58.71548	1803	ship								successful, Pull-out: 3.08T
Hebrides	JC073_155_ROV35	161	09/06/2012	15:49:39	56	31.770798	10	4.887012	1608	usbl	09/06/2012	22:38:19	57	29.66298	11	-53.378688	1219	ROV video transect for JNCC. Record for ROV on and off seabed
Hebrides	JC073_156_BC	162	10/06/2012	01:15:52	56	30.88721	9	58.64067	1803	ship								boxcore tangled up, no result. Pull-out: 2.19t
Hebrides	JC073_157_BC	162	10/06/2012	03:00:43	56	30.88733	9	58.64053	1803	ship								sample too disturbed for slicing, one brittlestar kept in bucket. Pull-out: 2.28t
Hebrides	JC073_158_BC	162	10/06/2012	05:32:37	56	30.8881	9	58.63876	1804	ship								successful core, pull-out: 2.13t
Hebrides	JC073_159_BC	162	10/06/2012	07:49:58	56	30.88772	9	58.63889	1806	ship								successful, pull-out: 2.24t
Hebrides	JC073_160_ROV36	162	10/06/2012	11:00:58	56	26.99529	10	17.850822	1011	usbl	10/06/2012	13:26:01	56	27.06259	10	18.9438	989	record for ROV on and off seabed. Transect for JNCC
														2				
														23.35444	10	6.630648		record for ROV on and off seabed. Transect for JNCC. (Ofop file failed halfway through, missing 1.5 hours of comments) shark egg case
														2				shark egg case
																		shark egg case
																		shark egg case
																		shark egg case, light brown, split upon sampling
Hebrides	JC073_162_BC	163	11/06/2012	02:38:04	56	29.9451	9	36.37518	1419	ship								failed, did not fire - got entangled. Pull-out: 3.37t
Hebrides	JC073_163_BC	163	11/06/2012	04:01:55	56	29.94468	9	36.37523	1418	ship								successful, pull-out: 3.11t
Hebrides	JC073_164_BC	163	11/06/2012	06:15:05	56	29.94486	9	36.37521	1419	ship								successful, pull-out: 3.14t
Hebrides	JC073_165_CTD	163	11/06/2012	09:38:00	56	34.85	10	18.703	1921	10	11/06/2012	10:21:00	56	34.85	10	18.704	1921	pumping water for aquaria
	JC073_165_CTD/DWP	163	11/06/2012	09:38:00	56	34.85	10	18.703	1921	35	11/06/2012	10:12:00	56	34.85	10	18.704	1921	
Hebrides	JC073_166_BC	163	11/06/2012	13:05:00	56	30.88727	9	58.64002	1801	ship								successful, pull-out: 3.3t. NIOZ corer
Hebrides	JC073_167_BC	163	11/06/2012	16:06:06	56	29.95352	9	36.4876	1421	ship								successful, pull-out: 3.2. NIOZ corer
Hebrides	JC073_168_BC	163	11/06/2012	18:25:21	56	29.95442	9	36.48731	1423	ship								successful, pull-out: 3.3t. NIOZ corer
Hebrides	JC073_169_BC	163	11/06/2012	20:41:16	56	29.95427	9	36.48799	1422	ship								successful, pull-out: 3.24t. NIOZ corer
Hebrides	JC073_170_BC	163	11/06/2012	23:32:33	56	28.92877	9	19.15526	1029	ship								successful, pull-out: 2.4t
Hebrides	JC073_171_BC	164	12/06/2012	01:41:05	56	28.92412	9	19.14974	1028	ship								successful, pull-out: 2.77t
Hebrides	JC073_172_BC	164	12/06/2012	03:31:00	56	28.92413	9	19.14999	1027	ship								did not fire, got tangled
Hebrides	JC073_173_BC	164	12/06/2012	04:32:44	56	28.9241	9	19.15071	1027	ship								no comments?? - photo taken, check buckets
Mingulay	JC073_174_ROV38	164	12/06/2012	12:15:49	56	49.05295	7	23.4104	181	ship	12/06/2012	12:52:42	56	49.0528	7	23.41082	181	dive aborted because MBES system did not work
	JC073_175_CTD	164	12/06/2012	13:25:00	56	49.052	7	23.411	181	173	12/06/2012	13:48:00	56	49.053	7	23.411	181	
	JC073_175_CTD/h01	164	12/06/2012	13:36:00	56	49.053	7	23.411	181	170								
	JC073_175_CTD/h02	164	12/06/2012	13:36:00	56	49.053	7	23.411	181	170								
	JC073_175_CTD/h12	164	12/06/2012	13:43:00	56	49.053	7	23.411	181	16								
	JC073_175_CTD/h13	164	12/06/2012	13:44:00	56	49.053	7	23.411	181	16								
Mingulay	JC073_176_CTD	164	12/06/2012	14:17:00	56	49.052	7	23.41	181	172	12/06/2012	14:46:00	56	49.052	7	23.411	181	
	JC073_176_CTD/h01	164	12/06/2012	14:31:00	56	49.051	7	23.411	180	170								
	JC073_176_CTD/h02	164	12/06/2012	14:32:00	56	49.051	7	23.411	180	170								
	JC073_176_CTD/h03	164	12/06/2012	14:33:00	56	49.051	7	23.411	180	170								
	JC073_176_CTD/h04	164	12/06/2012	14:33:00	56	49.051	7	23.411	180	170								
	JC073_176_CTD/h05	164	12/06/2012	14:33:00	56	49.051	7	23.411	180	170								
	JC073_176_CTD/h06	164	12/06/2012															

	JC073_176_CTDn19	164	12/06/2012	14:36:00	56	49.051	7	23.411	180	170	ship									
	JC073_176_CTDn20	164	12/06/2012	14:37:00	56	49.051	7	23.411	180	170	ship									
	JC073_176_CTDn21	164	12/06/2012	14:37:00	56	49.051	7	23.411	180	170	ship									
	JC073_176_CTDn22	164	12/06/2012	14:37:00	56	49.051	7	23.411	180	170	ship									
	JC073_176_CTDn23	164	12/06/2012	14:37:00	56	49.051	7	23.411	180	170	ship									
	JC073_176_CTDn24	164	12/06/2012	14:38:00	56	49.051	7	23.411	180	170	ship									
Mingulay	JC073_177_ROV39	164	12/06/2012	16:11:39	56	49.042842	7	23.419692	180		usbl	12/06/2012	00:49:17	56	49.19595	7	23.837418		ROV multibeam survey	
Mingulay	JC073_178_MBES/710	165	13/06/2012	01:35:00	56	50.22109	7	20.88943	228		ship	13/06/2012	11:27:00	56	47.36236	7	28.78111	80		
	JC073_178_MBES/SBP	165	13/06/2012	01:35:00	56	50.22109	7	20.88943	228		ship	13/06/2012	11:27:00	56	47.36236	7	28.78111	80		
Mingulay	JC073_179_ROV40	165	13/06/2012	12:25:50	56	49.320288	7	25.757832	117		usbl	13/06/2012	19:19:14	56	49.3374	7	23.947902			
	JC073_179_ROV40/BI0B05	165	13/06/2012	14:21:54	56	49.197138	7	25.081068			usbl								coral rubble	
	JC073_179_ROV40/BI0B06	165	13/06/2012	14:26:16	56	49.197108	7	25.080288			usbl								coral rubble	
	JC073_179_ROV40/BI0B05	165	13/06/2012	14:32:16	56	49.196832	7	25.08039			usbl								sponge? On coral rubble?	
	JC073_179_ROV40/MBIO01	165	13/06/2012	16:07:20	56	49.077408	7	24.461598			usbl								live lophelia	
	JC073_179_ROV40/MBIO02	165	13/06/2012	16:14:51	56	49.077042	7	24.46095			usbl								live lophelia	
	JC073_179_ROV40/MBIO03	165	13/06/2012	16:19:36	56	49.077018	7	24.461448			usbl								live lophelia	
	JC073_179_ROV40/BI0B01	165	13/06/2012	16:26:13	56	49.077132	7	24.461112			usbl								live lophelia, consisting of 5 slurp tubes full	
	JC073_179_ROV40/MBIO04	165	13/06/2012	18:44:23	56	49.334772	7	23.946732			usbl								live lophelia	
	JC073_179_ROV40/MBIO05	165	13/06/2012	18:47:46	56	49.334772	7	23.946738			usbl								live lophelia	
	JC073_179_ROV40/MBIO06	165	13/06/2012	18:51:52	56	49.33485	7	23.947008			usbl								live lophelia	
	JC073_179_ROV40/BI0B07	165	13/06/2012	18:56:13	56	49.33464	7	23.94672			usbl								live lophelia	
	JC073_179_ROV40/BI0B07	165	13/06/2012	18:59:26	56	49.334532	7	23.946912			usbl								live lophelia	
Mingulay	JC073_180_ROV41	165	13/06/2012	20:18:15	56	49.545732	7	23.491848	168		usbl	13/06/2012	23:40:38	56	49.34172	7	23.629248	136		
	JC073_180_ROV41/BI0B05	165	13/06/2012	21:10:29	56	49.444338	7	23.574588			usbl								red lophelia	
	JC073_180_ROV41/BI0B06	165	13/06/2012	21:37:03	56	49.43025	7	23.573232			usbl								white lophelia	
	JC073_180_ROV41/BI0B07	165	13/06/2012	21:41:05	56	49.430268	7	23.57292			usbl								white lophelia	
	JC073_180_ROV41/BI0B07	165	13/06/2012	22:48:28	56	49.33809	7	23.642898			usbl								white lophelia	
	JC073_180_ROV41/BI0B07	165	13/06/2012	22:51:45	56	49.338	7	23.64258			usbl								sponge	
	JC073_180_ROV41/BI0B01	165	13/06/2012	22:52:58	56	49.337982	7	23.64252			usbl								white lophelia	
	JC073_180_ROV41/BI0B07	165	13/06/2012	22:54:14	56	49.337592	7	23.642658			usbl								sponge	
	JC073_180_ROV41/BI0B07	165	13/06/2012	22:55:36	56	49.33761	7	23.642508			usbl								white lophelia	
	JC073_180_ROV41/BI0B02	165	13/06/2012	23:16:00	56	49.35036	7	23.615868			usbl								sponge	
	JC073_180_ROV41/BI0B03	165	13/06/2012	23:18:49	56	49.349748	7	23.615028			usbl								sponge	
	JC073_180_ROV41/BI0B08	165	13/06/2012	23:31:50	56	49.34313	7	23.628498			usbl								lophelia, 3 slurp tubes full	
Mingulay	JC073_181_MBES/710	166	14/06/2012	00:18:54	56	49.7695	7	22.96453	191		ship	14/06/2012	06:00:08	56	50.2727	7	21.10786	227		
	JC073_181_MBES/SBP	166	14/06/2012	00:18:54	56	49.7695	7	22.96453	191		ship	14/06/2012	06:00:08	56	50.2727	7	21.10786	227		filling in gaps from previous survey & extension

Appendix 2: CTD configuration

Date: 08/06/2012

Instrument configuration file:

\\cookfs.cook.local\public\CTD\JC073_pri_cond_NMEA.xmlcon

Configuration report for SBE 911plus/917plus CTD

Frequency channels suppressed: 0
Voltage words suppressed: 0
Computer interface: RS-232C
Deck unit: SBE11plus Firmware Version >= 5.0
Scans to average: 1
NMEA position data added: Yes
NMEA depth data added: No
NMEA time added: No
NMEA device connected to: deck unit
Surface PAR voltage added: No
Scan time added: No

1) Frequency 0, Temperature

Serial number: 03P-4782
Calibrated on: 14 October 2011
G: 4.35000600e-003
H: 6.36663654e-004
I: 2.10215719e-005
J: 1.79693399e-006
F0: 1000.000
Slope: 1.00000000
Offset: 0.0000

2) Frequency 1, Conductivity

Serial number: 04C-2580
Calibrated on: 12 October 2011
G: -1.04826159e+001
H: 1.54089648e+000
I: 1.05490403e-004
J: 7.42359560e-005
CTcor: 3.2500e-006
CPcor: -9.57000000e-008
Slope: 1.00000000
Offset: 0.00000

3) Frequency 2, Pressure, Digiquartz with TC

Serial number: 100898
Calibrated on: 6 January 2012
C1: -4.405863e+004
C2: -6.206030e-002
C3: 1.337540e-002
D1: 3.669100e-002
D2: 0.000000e+000
T1: 2.990734e+001
T2: -3.493620e-004
T3: 4.061200e-006
T4: 3.043880e-009

T5: 0.000000e+000
Slope: 0.99995000
Offset: -1.59900
AD590M: 1.288520e-002
AD590B: -8.271930e+000

4) Frequency 3, Temperature, 2

Serial number: 03P-2674
Calibrated on: 21 January 2012
G: 4.35678630e-003
H: 6.42260602e-004
I: 2.34777951e-005
J: 2.30310109e-006
F0: 1000.000
Slope: 1.00000000
Offset: 0.0000

5) Frequency 4, Conductivity, 2

Serial number: 04C-2231
Calibrated on: 21 January 2012
G: -1.07821697e+001
H: 1.69879795e+000
I: -3.61127839e-003
J: 3.77195210e-004
CTcor: 3.2500e-006
CPcor: -9.57000000e-008
Slope: 1.00000000
Offset: 0.00000

6) A/D voltage 0, Oxygen, SBE 43

Serial number: 43-0619
Calibrated on: 22 October 2011
Equation: Sea-Bird
Soc: 5.09100e-001
Offset: -5.00400e-001
A: -3.71370e-003
B: 1.62450e-004
C: -3.03420e-006
E: 3.60000e-002
Tau2: 2.39000e+000
D1: 1.92634e-004
D2: -4.64803e-002
H1: -3.30000e-002
H2: 5.00000e+003
H3: 1.45000e+003

7) A/D voltage 1, Free

8) A/D voltage 2, Altimeter

Serial number: 41302
Calibrated on: 20 April 2007
Scale factor: 15.000
Offset: 0.000

9) A/D voltage 3, Turbidity Meter, WET Labs, ECO-BB

Serial number: BBRTD-759R
Calibrated on: 18 May 2010
ScaleFactor: 0.003130
Dark output: 0.048000

10) A/D voltage 4, Free

11) A/D voltage 5, PAR/Irradiance, Biospherical/Licor

Serial number: 11
Calibrated on: 14 June 2011
M: 0.43350200
B: 2.34999500
Calibration constant: 100000000000.00000000
Multiplier: 0.99980000
Offset: 0.00000000

12) A/D voltage 6, Fluorometer, Chelsea Aqua 3

Serial number: 088-195
Calibrated on: 8 September 2010
VB: 0.275800
V1: 2.154100
Vacetone: 0.313700
Scale factor: 1.000000
Slope: 1.000000
Offset: 0.000000

13) A/D voltage 7, Transmissometer, Chelsea/Seatech

Serial number: 161048
Calibrated on: 28 May 2008
M: 24.5574
B: -0.4420
Path length: 0.250
Scan length: 37

Appendix 3: Box core photographs

Box coring station	Deck photograph
<p>JC073_077 Logachev Mounds 874 m</p>	
<p>JC073_078 Logachev Mounds 877 m</p>	
<p>JC073_079 Logachev Mounds 874 m</p>	
<p>JC073_091 Logachev Mounds 661 m</p>	
<p>JC073_092 Logachev Mounds 659 m</p>	

JC073_103
Logachev Mounds
884 m



JC073_106
Logachev Mounds
696 m



JC073_107
Logachev Mounds
693 m



JC073_154
Hebrides Terrace Slope
1803 m



JC073_158
Hebrides Terrace Slope
1803 m



JC073_159
Hebrides Terrace Slope
1806 m



JC073_163
Hebrides Terrace Slope
1418 m



	
<p>JC073_164 Hebrides Terrace Slope 1418 m</p>	
<p>JC073_166 Hebrides Terrace Slope 1801 m</p>	
<p>JC073_167 Hebrides Terrace Slope 1421 m</p>	



JC073_168
Hebrides Terrace Slope
1421 m



JC073_169
Hebrides Terrace Slope
1422 m



JC073_170
Hebrides Terrace Slope
1029 m



JC073_171
Hebrides Terrace Slope
1028 m



JC073_173
Hebrides Terrace Slope
1027 m



Appendix 4: ROV track-plots

Dives 1, 2, 3

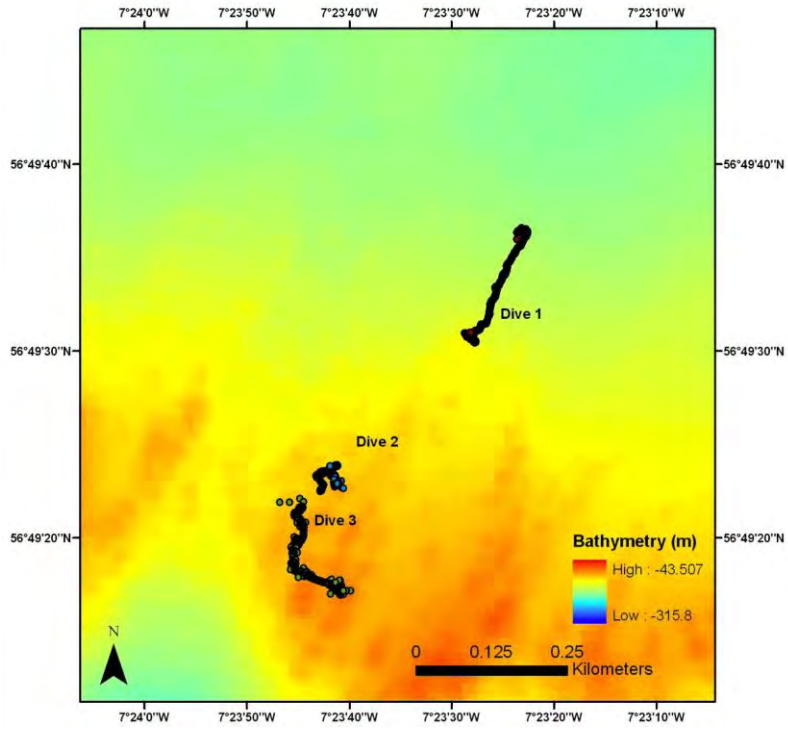

Dives 4, 5, 6

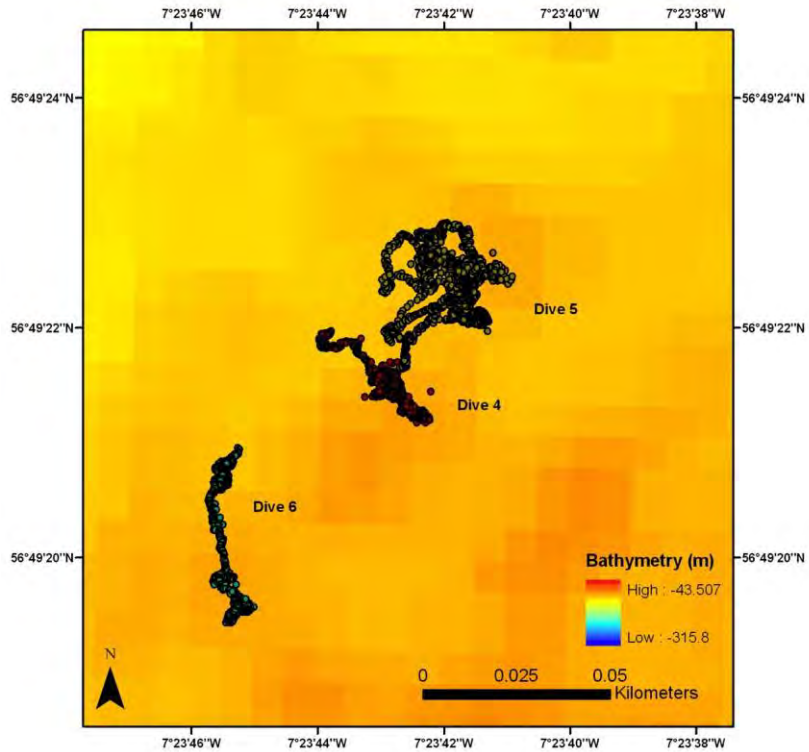

Dive 7

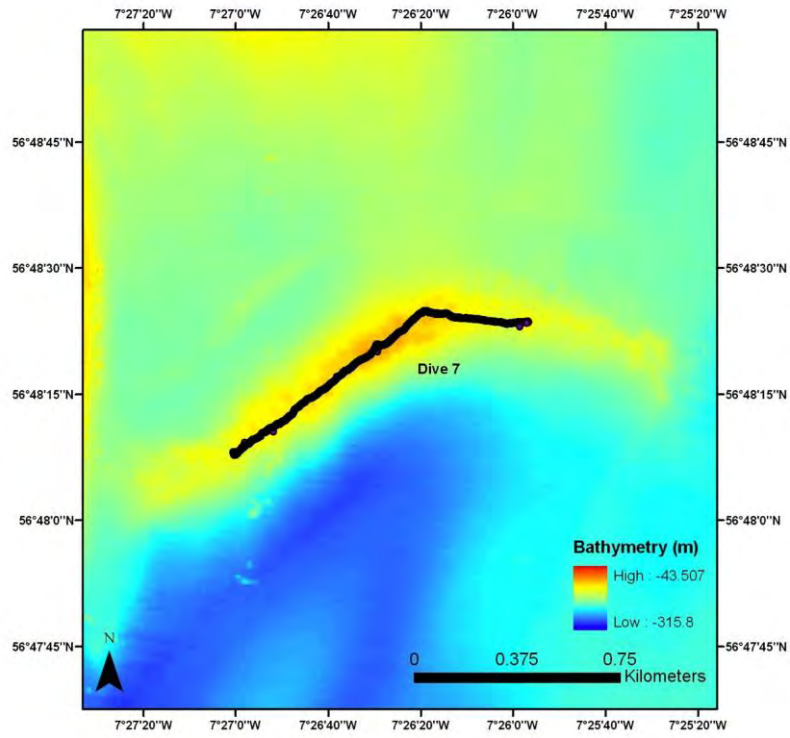

Dive 8

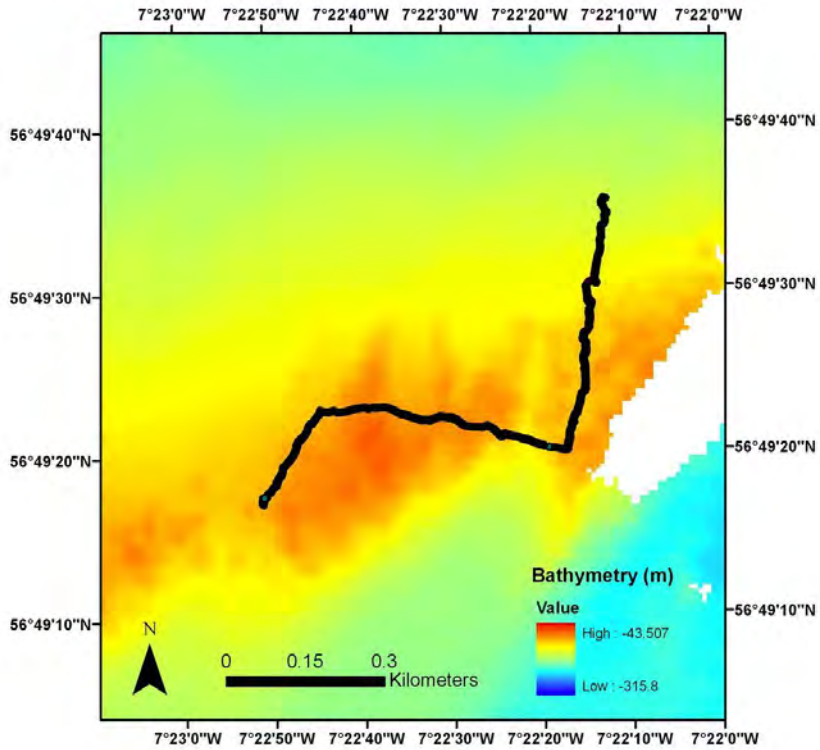

Dives 9, 10

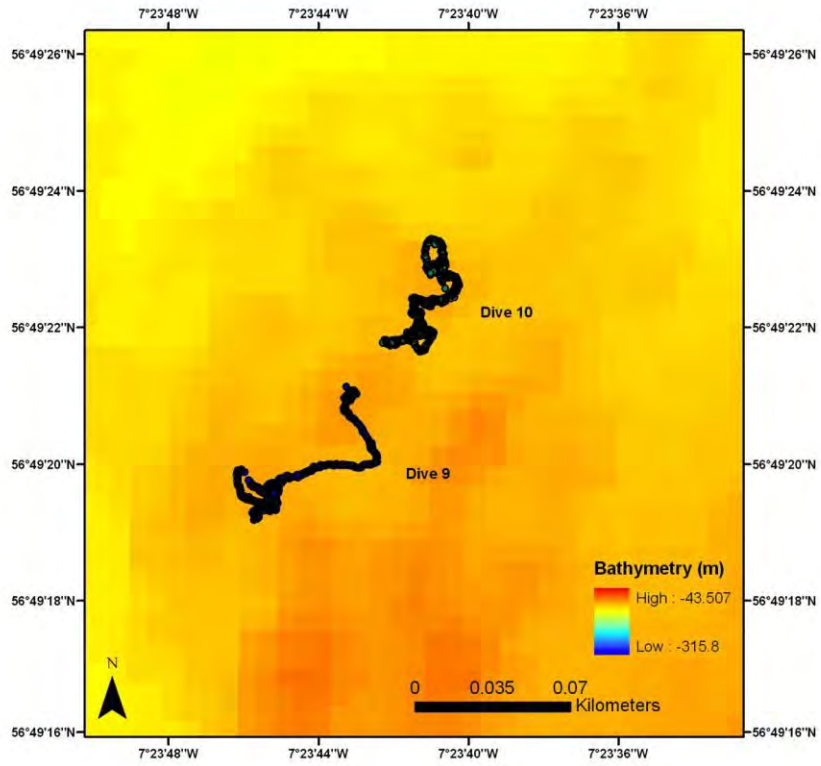

Dive 11

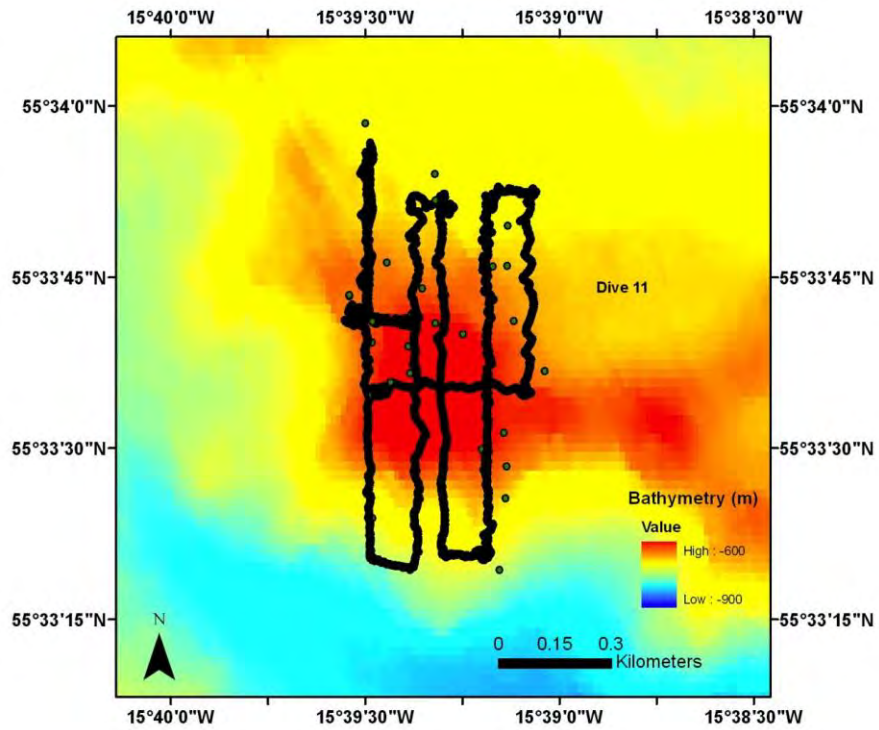

Dive 12

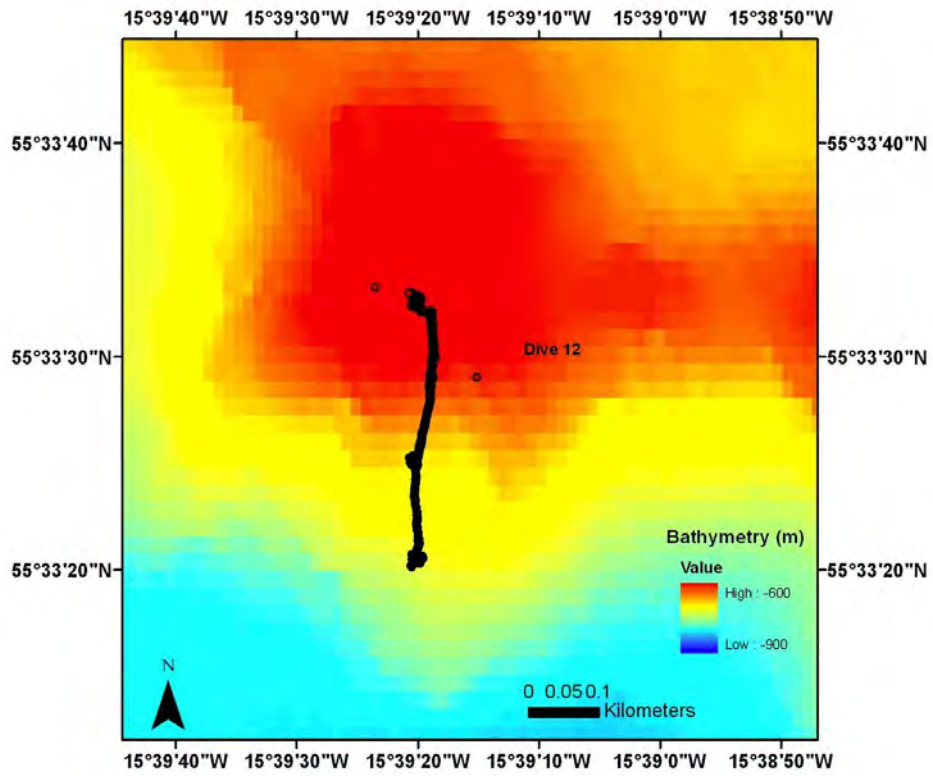

Dives 13, 14

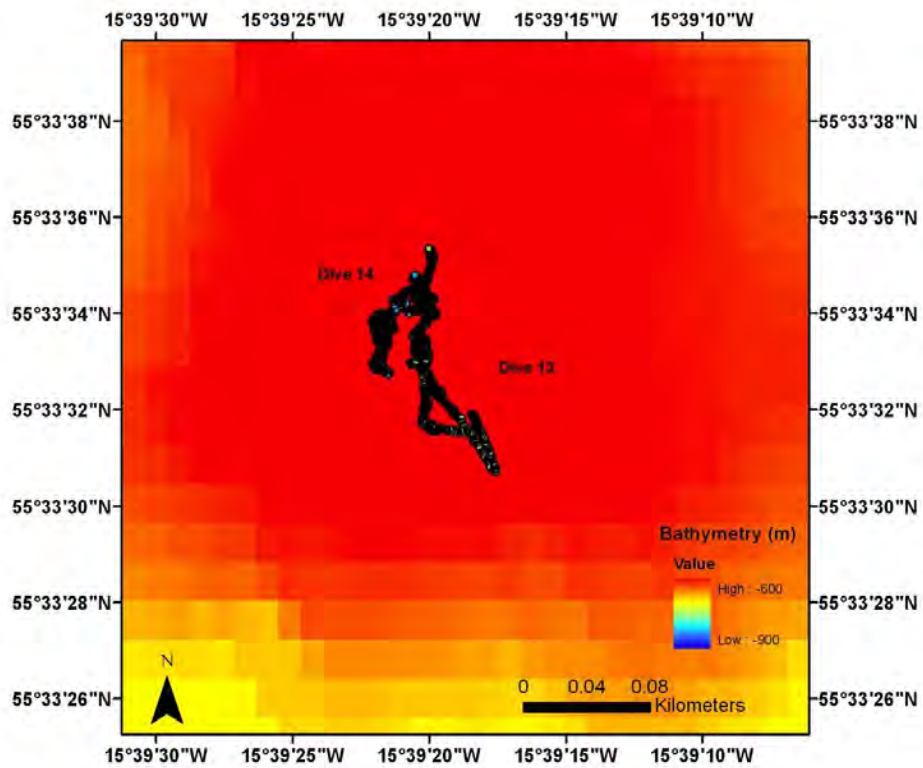

Dive 15

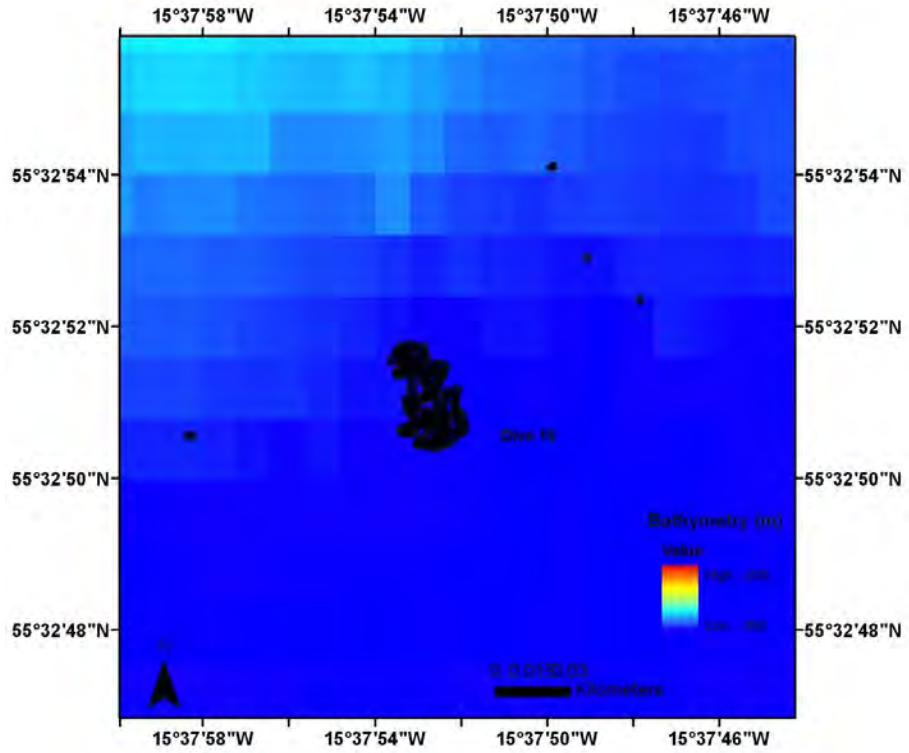

Dive 16

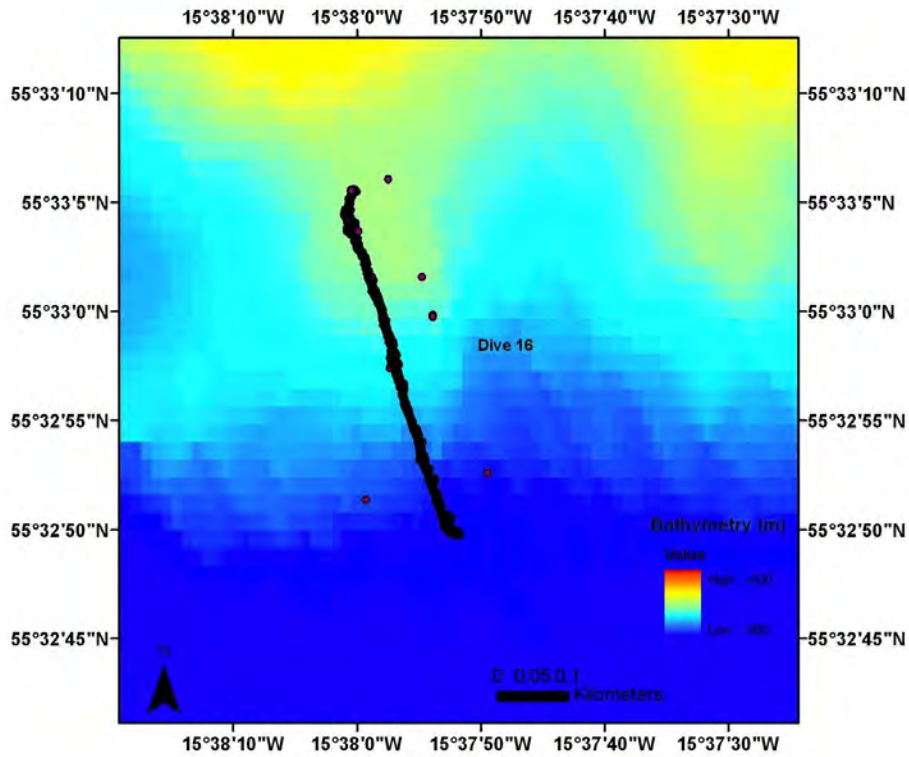

Dive 17

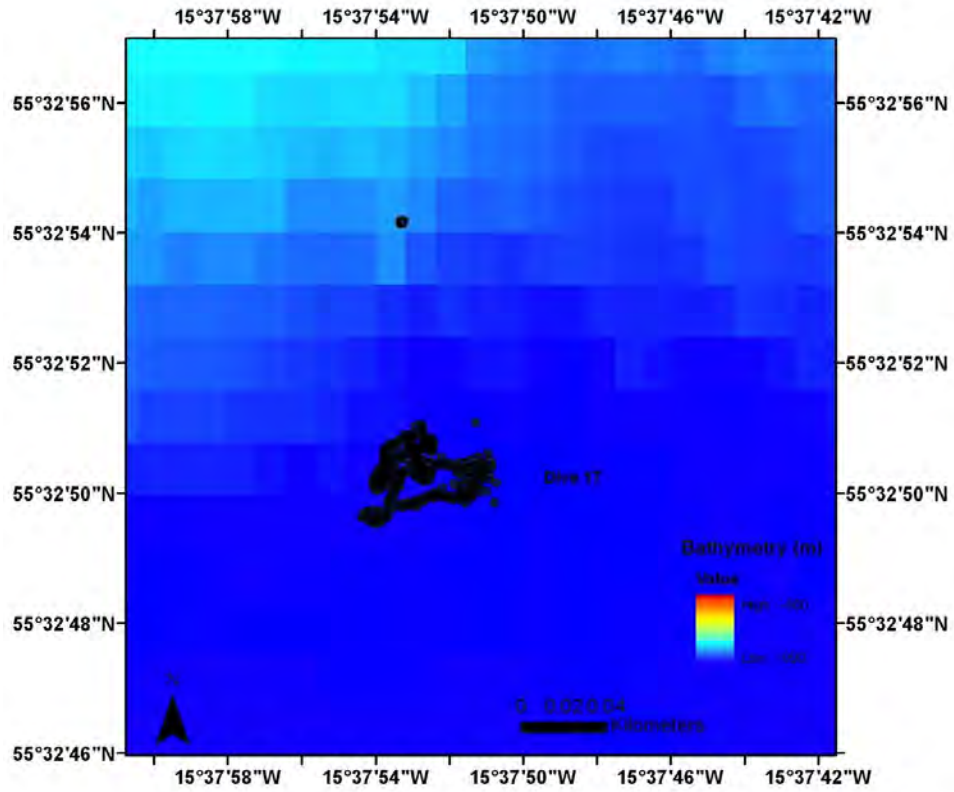

Dive 18

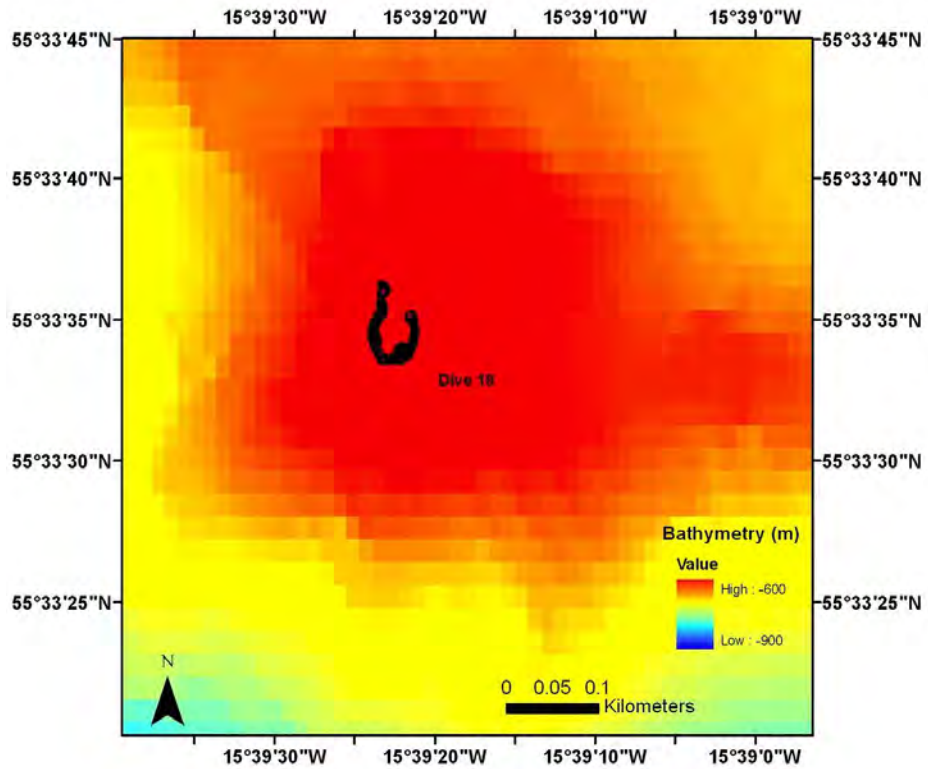

Dives 19, 20

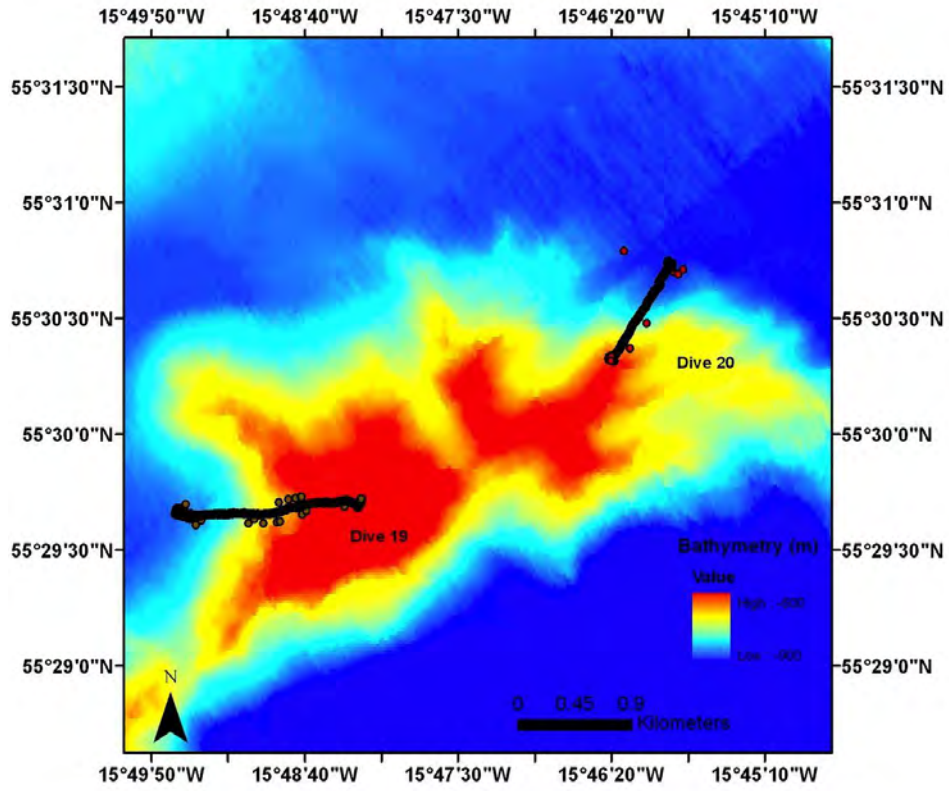

Dive 21

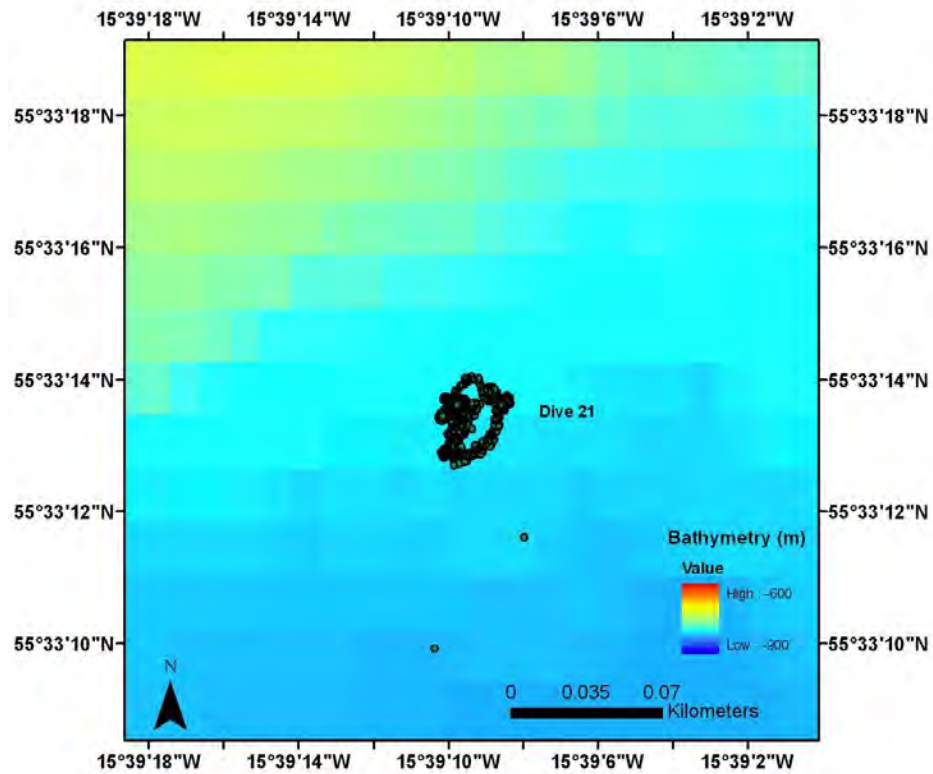

(Dive 22 aborted)

Dive 23

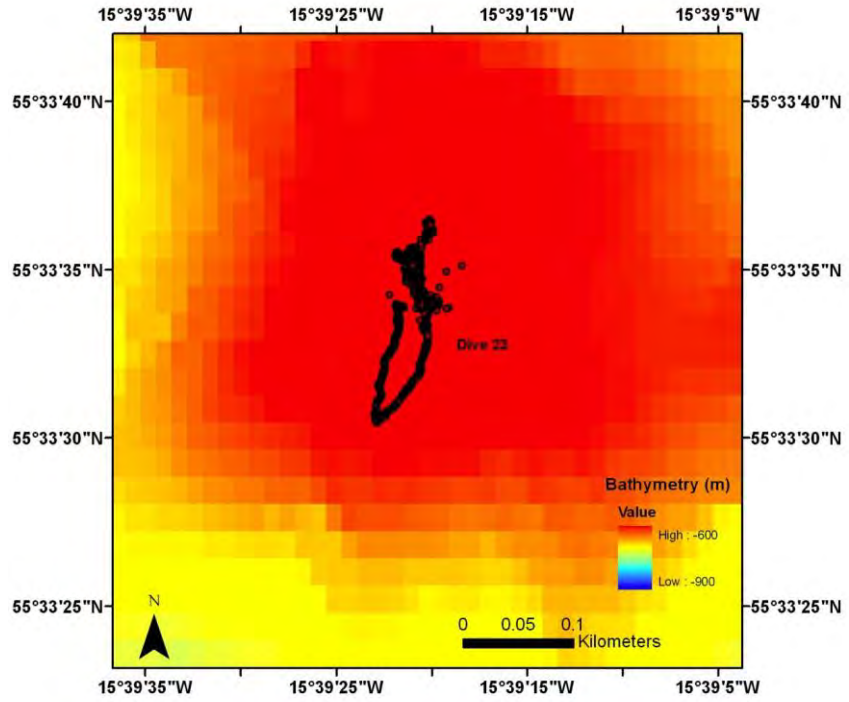

Dive 24

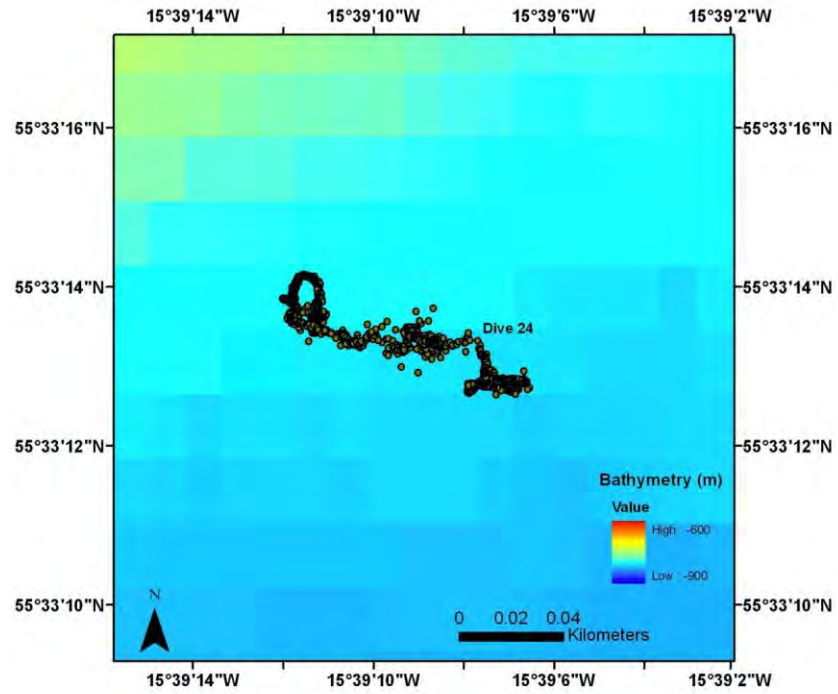

Dive 25

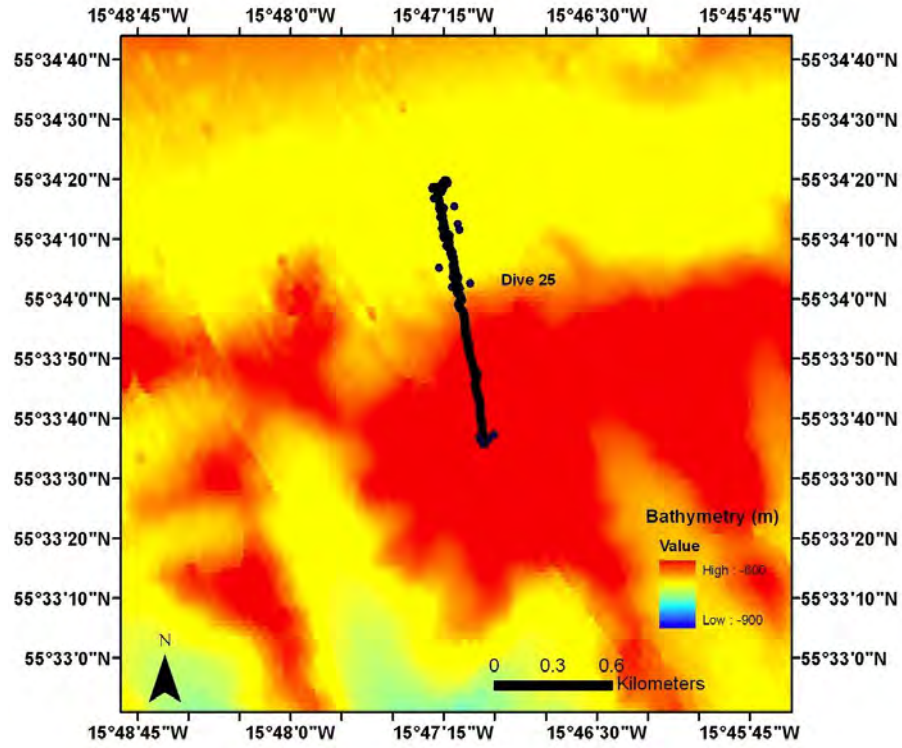

Dive 26

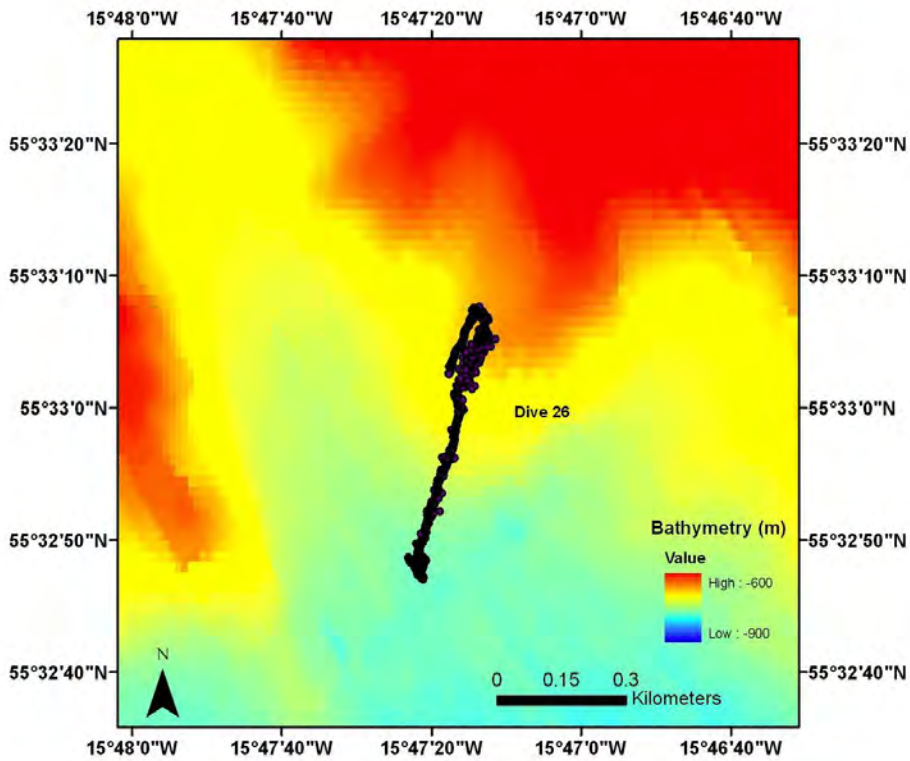

(Dive 27 aborted)

Dive 28

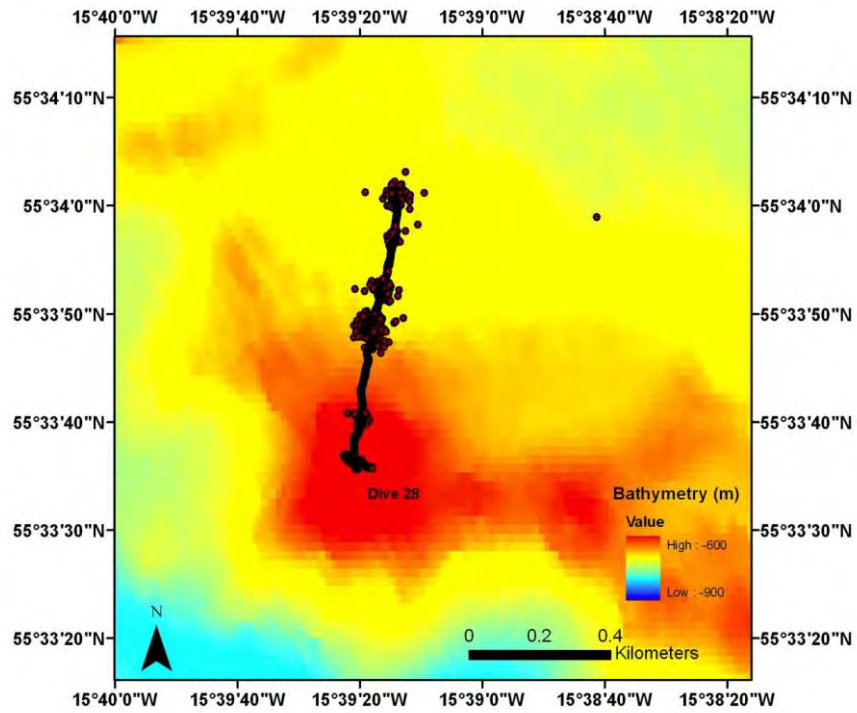

(Dive 29 aborted)

Dive 30

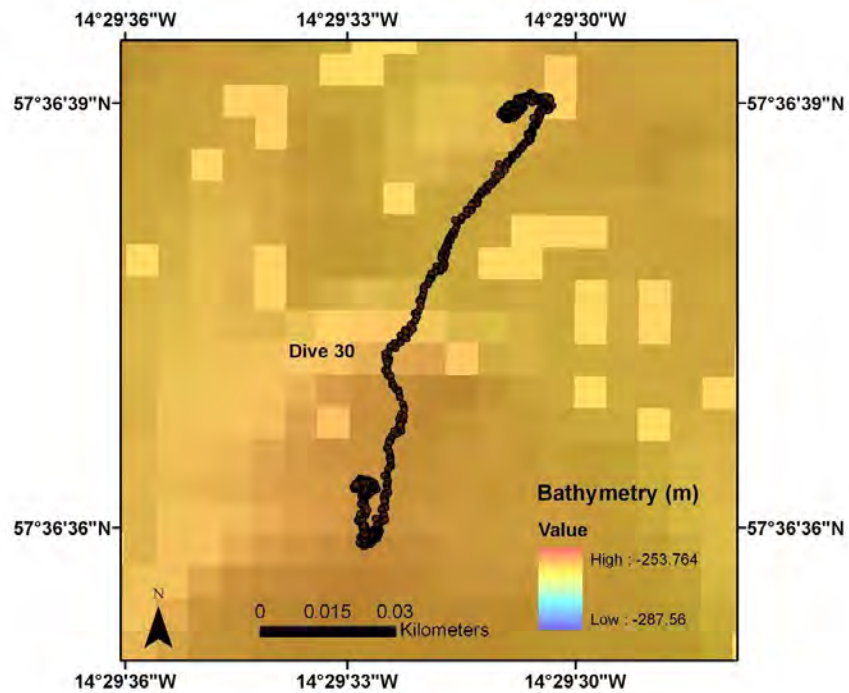

Dive 31

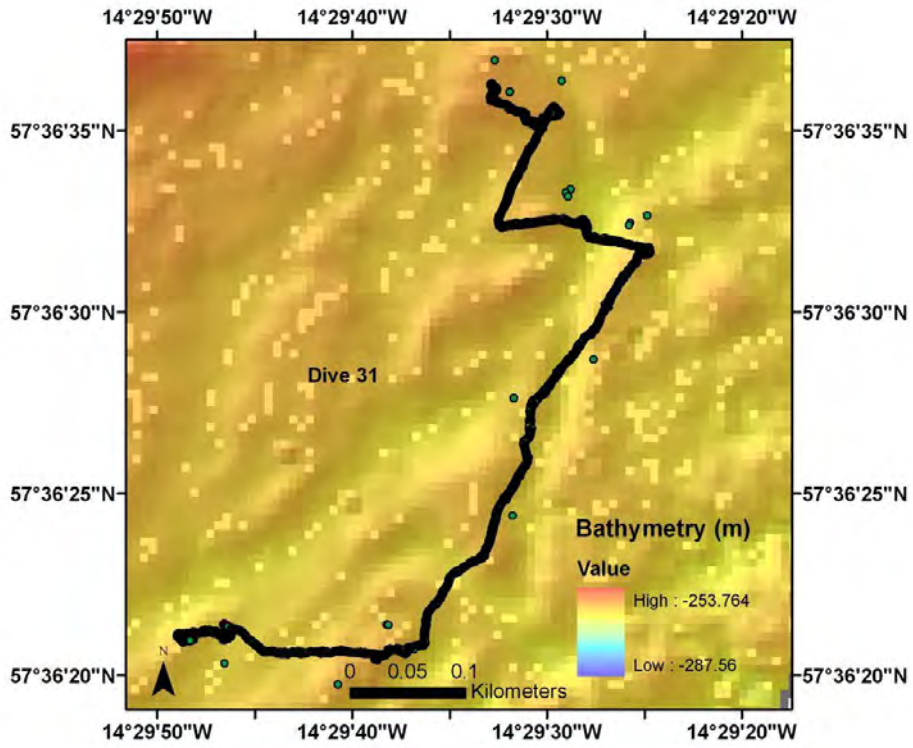

Dive 32

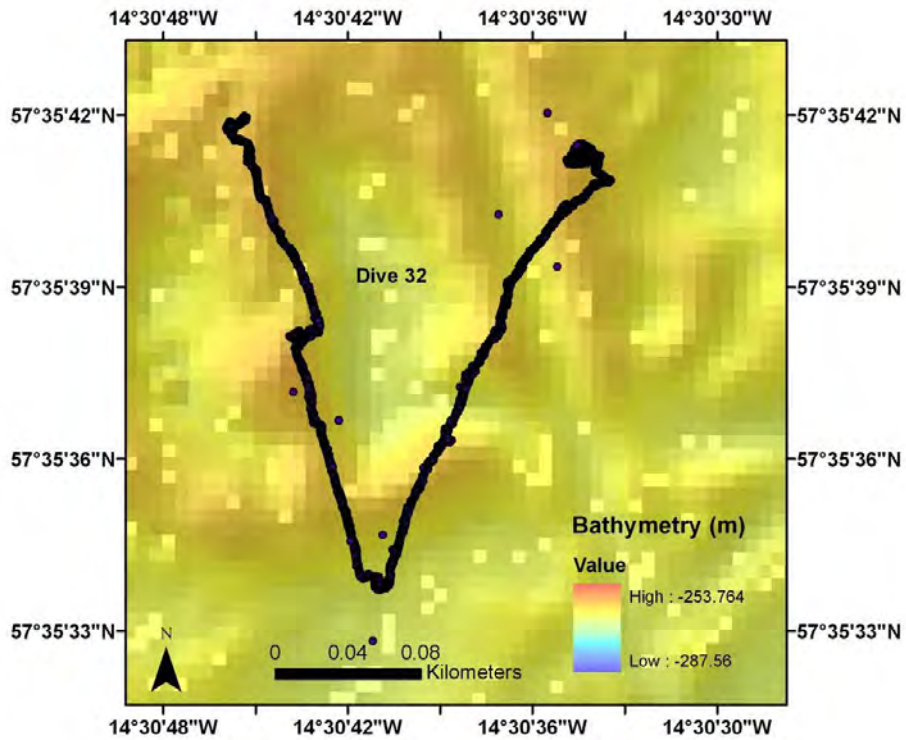

Dives 33, 34

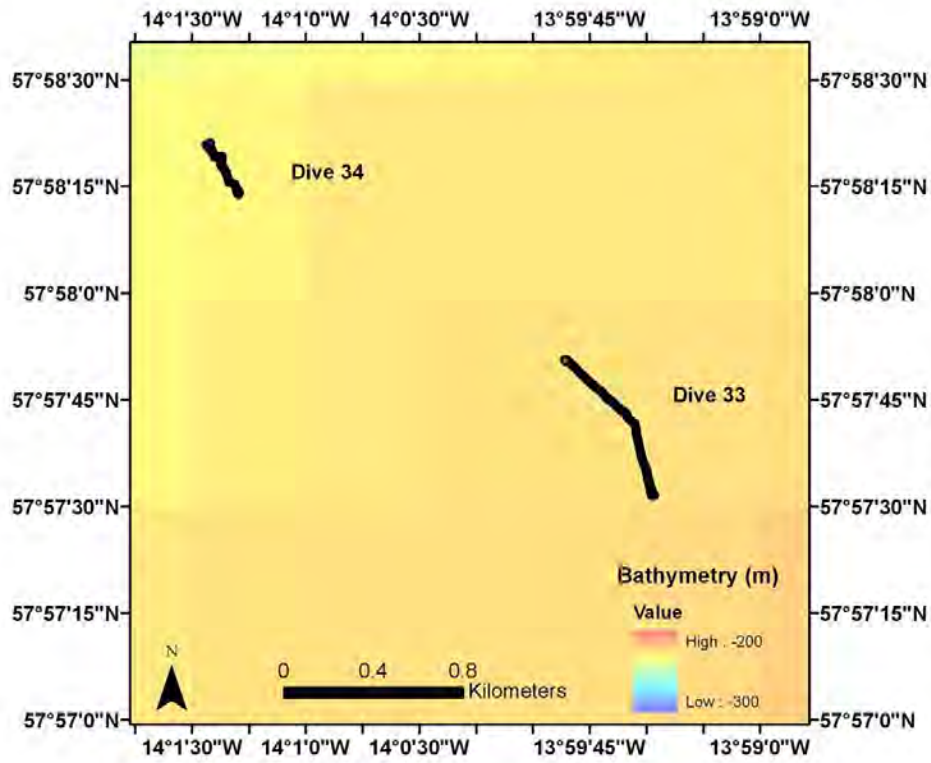

Dives 35, 36, 37

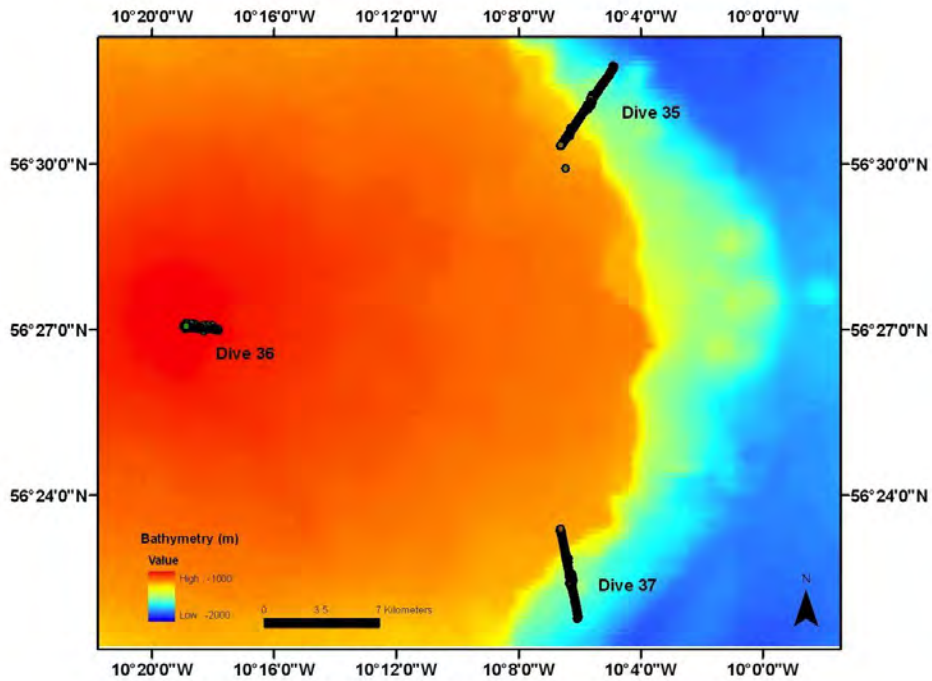

(Dive 38 aborted)

Dive 39

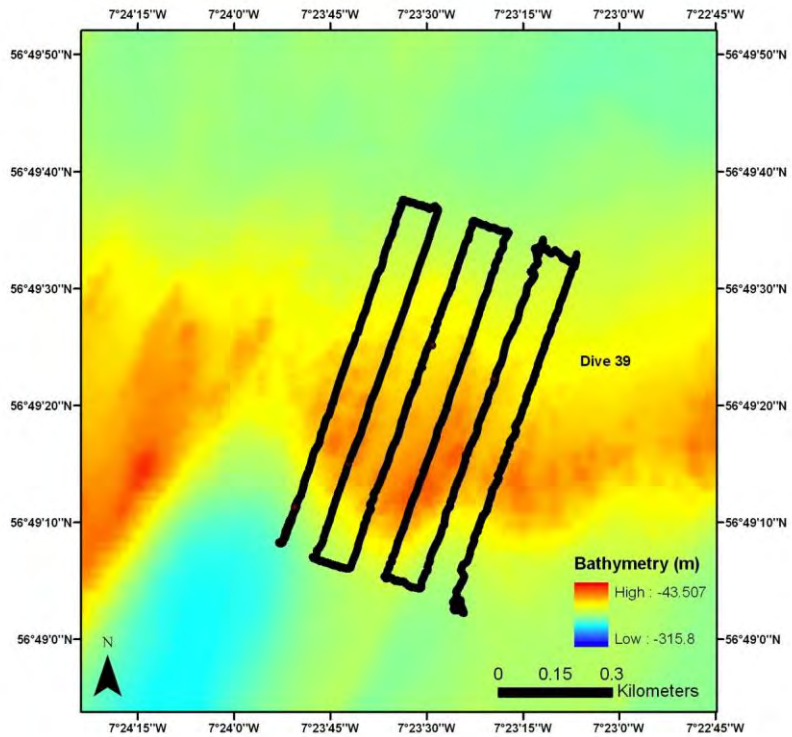

Dives 40, 41

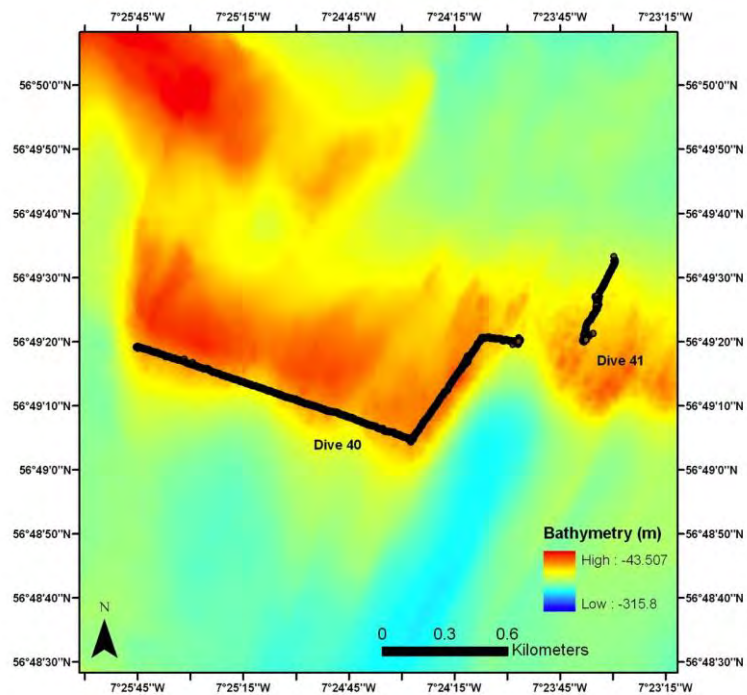

Appendix 5: Blog posts

1. And so it begins Today marks the start of the cruise for many of us, as we began to load up the ship in Glasgow. Although the day started off sunny, in typical British fashion the storm clouds opened, just in time for our arrival at the dockside.

The 90 m ship dominates the dockside at Govan, there are cranes moving equipment onto the aft deck at the same time as technicians welding the ROV stand (at least that's what I think it was!). We were all excited to see our home for the next month!

Computers are rapidly being assembled in the dry lab, while aquariums are getting set up in the hanger. With so much to do and so little time in dock, it had to be a carefully planned operation. Tomorrow morning will see a ministerial visit - MSP Stewart Stevenson will be visiting the ship in the morning, but that's only the start of a busy day for us all. More scientists will be arriving with their equipment, there will be a crew change at midday and most importantly, food for 54 people for a month will arrive. That's a lot of trolleys at Tesco!

Posted [Monday, May 14, 2012](#)

Written by Laura Wicks

2. VIPs, plus Scientists with drills Today was a busy day on the ship, with scientists arriving, a crew change and visits from the Scottish Minister for Environment and Climate Change, Stewart Stevenson, Heriot-Watt University Principal Steve Chapman and a BBC News team.

The day started off sunny for our VIPs, who toured the ship and met some of the crew and scientists about to embark on the expedition. Work didn't stop with so much to do; more boxes were loaded, chemicals were unpacked, and our Captain arrived, ready to take the helm. Despite the ship being massive, the process of unpacking in the labs and making sure everything is accessible yet secure is quite a challenge. Scientists with drills, bungee cords and pink twine were abundant in the labs, making sure that even if we hit gale force winds, everything would be stable (well maybe not the scientists!)

The windy conditions in Glasgow made some of the work uncomfortable, but that will be nothing compared to the challenges that await us in the North Atlantic. Tomorrow, 21 scientists will move onto the ship, ready for scientific discovery!

Posted [Tuesday, May 15, 2012](#)

Written by Laura Wicks

3. All Aboard Today was yet another day of unpacking and organising - mobilising the ship takes a lot of hands on deck. The ROV (remotely operated vehicle) team have been busy checking and double checking everything - everything needs to be perfect before the robot can descend to 1000 m!

In the hanger, scientists have become plumbers, connecting tanks and chillers to large aquarium tanks, ready for the corals we hope to collect at the reefs. All the scientists have arrived, and are excited for their impending adventure.

Everything was pretty exhausted by the end of the day, and still yet to unpack our personal stuff for our first night on the ship. Tomorrow is the big day, fingers crossed for sunshine!

Posted [Wednesday, May 16, 2012](#)

Written by Laura Wicks

The Master Plan Work on the ROV continues, and we have a new sail date of tomorrow. This has allowed us some extra time to make sure everything is perfect onboard the ship, and a few last minute trips to B&Q!

Everyone is raring to go, and we had our first science meeting this morning, where we make the master plan for all the teams - Team Coral, Team SPI, Team Microbe, Team Spreader, Team Coring, Team Multibeam, and Team CTD/SAP.

Filming started, with our two expert camera people getting some great shots of work going on around the ship - we hope to upload some amazing videos when we get back to shore!

For now, its time to relax, and enjoy the calm before the storm.

Posted [Thursday, May 17, 2012](#)

Written by Laura Wicks

Day 1: Leaving Glasgow, woohoo! The Changing Oceans Expedition is underway! At 6pm, the RRS James Cook cast off from Govan, and headed west along the River Clyde. In 20 hours' time we will arrive at Mingulay and the science will start!

This was a very exciting moment for scientists and crew, who have been eagerly waiting for the view alongside the ship to change - especially those in the lower cabins that have had a brick wall to look at through their portholes for the past few days. The skies were grey as we left Govan, but the rain didn't stop most of the scientists gathering on the deck at the bow to watch us cast off. The gangplank was removed, the tethers were drawn in and we were off. Some friendly Glaswegians waved us off as we headed under the Erskine Bridge, including a local teacher who hopes to feature us in the school mural!

The weather outlook is good, so we're all hoping for brilliant Scottish sunshine tomorrow for our first day of science.

Posted [Friday, May 18, 2012](#)

Written by Laura Wicks

Day 2: Testing Times Waking up to bright Scottish sunshine immediately put both scientists and crew in a good mood, and we arrived at Mingulay Reef Complex ahead of schedule. The sunglasses were out, and there was even talk of shorts!

Once at site, testing of all the scientific equipment began. While all our gear works perfectly in the lab it can be a different matter when hundreds of meters underwater and subject to immense pressure.

The moving vessel profiler was deployed, and with a bit of tweaking, was soon giving us information about the temperature and salinity around the reef, and even the size of particles in the water column.

This was followed by the CTD rosette and deep-water pump. The CTD rosette basically consists of an array of water bottles which were triggered to close remotely, allowing us to get water samples deep on the reef and all the way up to the surface. More about the CTD can be found on the equipment page. Courtesy of Janina from GEOMAR, we had a deep-water pump, which we can hook up to the CTD rosette, deploy to 50 m and pump that deeper water back up to the ship. We will use this water in the coral tanks, so when we bring the animals up they are in water that is similar to their environment on the reef. The 50 m length of hosing required many hands on deck, making sure it didn't get hooked up on any other equipment. Everyone took this opportunity to be out in the sunshine, and cameras were at the ready to see the first piece of equipment over the side of the ship!

Team SPI were next up with the test run, and the images taken were spectacular – some stunning crinoids. That was a tick in the box for the SPI camera test.

Finally, the ROV went in the water, and we waited with baited breath for our first views of the reef. We weren't disappointed, at 160 m the reef appeared and we saw ophiuroids, worms, and fish around the bright white *Lophelia* reefs. The highlight of the dive was the appearance of a basking shark, who was obviously intrigued by this yellow robot appearing at its home! Corals were collected, and made their new homes in our carefully prepared tanks, ready to be part of some science!

For the scientists, day 2 marked the start of shift work, so the night team started to stagger their sleeps so they could be up and raring to go at midnight, working through until midday. Although it's a challenge to be up and ready at midnight, we are rewarded with the daily sunrise, a spectacular site in the Hebrides. Tomorrow will be another exciting day, with a visit from the BBC One Show and schoolchildren from the Isle of Benbecula – a great opportunity for them to see what we do, and for us to show what science can bring.

Posted [Sunday, May 20, 2012](#)

Written by Laura Wicks

Day 3: Science Communication Day Today was a bit of a different day for everyone aboard James Cook. Eleven scientists were treated to a day on the Isle of Barra, to make way for a school group from Sgoil Lionacleit and a BBC team from 'The One Show'. It was nice for the scientists to talk about their research and show off their toys.

The 'Boy James' arrived at the ship after breakfast, and with some to-ing and fro-ing on the rope ladder the transfer was made.

From Sgoil Lionacleit on the Hebridean isle of Benbecula, four pupils, Anna, Angharad, Erin and Magnus, came onboard to experience life on a research ship, and to see the corals that are on their own doorstep. After a tour of the ship, including the ships massive food store (so many baked beans!), they each had a go in the captains chair, both teachers and pupils! It was then ROV time, with Captain Bill and the ROV pilot in close communication to ensure both the ship and ROV were in the right position. Along with the remaining scientists, the school group and BBC gathered round the high definition screens in the plot, and watched as we hit bottom and then the bright white reefs appeared out of the gloom. Everyone was excited about their first glance of the reefs, and surprised by how many animals were milling around the coral polyps. We saw an edible crab, worms, sea pens, and a variety of fish species, including the elusive catshark!

The ROV went on a brief tour of the reef, finding more and more cauliflower-shaped *Lophelia* colonies, before the children got their own go at controlling the ROVs cameras - more than most of the scientists get to do! We will hear more about the experience of the school group, and their favourite aspects of the ship when they write their own blog later on this week.

The whole day was a fantastic opportunity for us to talk about what we do, and show how important these reefs are and why they need to be protected and looked after. Everyone was exhausted after their full-on day, so after waving off the visitors and welcoming back returning scientists, the night shift retired. The day shift were still on ROV duty, and the robot was back in the water and back to the reefs in search of corals!

Posted on [Monday, May 21, 2012](#)

Day 4: SPI-ing at Mingulay Today was a very exciting time for 'team SPI'. Silvana and Nigel from CEFAS managed to collect their first deep-water SPI images. We saw some nice Crinoids, sponges, stony corals and erect polychaete tubes. So, we will continue with our SPI transects during the cruise.

The Sediment Profile Imagery (SPI) is an in-situ technique, which takes vertical profile pictures of the upper 20cm of soft sediments. The images can provide clear insight into the relationship between fauna and their Habitat. This information is very important for our scientific work, since we can now begin to understand some of the existing biodiversity and function (e.g. bioturbation) of the communities adjacent to *Lophelia pertusa* (cold-water coral reefs) at Mingulay.

We will be able to integrate this data as baseline information to understand the potential effects caused by ocean acidification on these systems.

Posted on [Tuesday, May 22, 2012](#)

Written by Silvana Birchenough

Day 5: Feeding Corals After one week on board, we already have healthy corals in our tanks, and will use these corals to learn more about their ecology.

Today's blog has been written by Covadonga Orejas, from the Instituto Espanol de Oceanografia, Spain. During this cruise, exciting *in situ* experiments will be performed by some of the scientist. Another way to learn more about the ecology of deep sea organisms is to conduct aquaria experiments on the ship. Knowing what the animals feed on will help us to better understand their role in the ecosystem.

Yesterday, we started some of the feeding experiments that will be carried out during the Changing Oceans Expedition. Previous studies at home showed us that the coral *Lophelia*, the main "star" of this cruise, feeds on zooplankton and algae. However, we still do not know much about the other food sources in the ocean that could be consumed by this coral. At the depth of the reef, zooplankton could be scarce in some periods during the year, and phytoplankton is available in sufficient amounts, particularly during spring and summer. However, other particles (like bread crumbs...) are constantly present in the oceans, and even if they don't supply much energy due to their small size, they could be consumed in large amounts and constantly. Therefore, these particles, which scientists call particulate organic matter, could be one of the "secure" food sources for this organism in times when obtaining other prey is difficult. So we want to look at the uptake rates by *Lophelia* of these very small organic particles that float in the plankton.

Healthy corals, filtered seawater and 9°C temperatures are the main ingredients for the 'feeding experiments recipe". Once the aquaria are filled with chilled filtered seawater, and the corals feel comfortable in their chambers, we just need to add our "main course" so that we can later analyse what the corals actually ate.

In the natural environment, sea animals live under different current regimes, and animals that don't move around and filter particles out of the surrounding water are very dependent on these currents, which move the food to their tentacles. With this in mind, we developed experiments using different current speeds so that we can see which current speed is best for the corals to capture their food.

When we go back home, we will analyse the samples obtained from the experiments, and then know what the corals are eating. This will help us to better understand the ecological role that these animals play in the ecosystem. Many other things are going on board! The ROV has been in the water collecting corals, we have been box coring for benthic samples and we have had success with the microbial collection chambers! We will keep you updated!

Posted on [Wednesday, May 23, 2012](#)

Written by Cova Orejas

Day 6: Helen's water..... Today's blog is written by Helen Findlay from Plymouth Marine Lab. As another sun rises into view through the porthole of the chemical lab, I count how many samples I have left to analyse (40), and not for the first time on this trip, wonder why oh why I collected so many samples.

Why am I sat here at 4 am, watching two machines slowly pipette acid into a small bottle of seawater? Why do I do this for over 12 hours a day while at sea? My job on this research trip is to collect and analyse seawater samples for carbon chemistry and other oceanographic parameters, like temperature, salinity, and chlorophyll. This sort of general environmental information allows us to know what the conditions are like in the water column above the reef, which the rest of the people on the cruise are interested in studying. Without knowing what the organisms and reef critters actually experience (especially in the context of ocean acidification), it's difficult to put results from laboratory studies into any sort of context. Also, there are some interesting tidal dynamics around the Mingulay Reef and I'm interested to know of these have an impact on the carbon cycle – for example to investigate whether these dynamics effect how the ocean can take up carbon dioxide (CO₂) from the atmosphere. This all makes my job seem quite important, and that make sitting in a lab for over 12 hours a day seem worthwhile!

During the "night" shift (midnight to midday) it's pretty quiet in the chemistry lab. Every ten minutes or so I hear a soft beeping of my machine, telling me it's ready for a new sample – talk about Pavlov's dogs! After just a few days, whenever I hear a beep, I was trained to jump up and look for a new bottle of seawater! The rest of the time I sit with my laptop doing other work, watching the sun get higher in the sky through the port-hole, the waves roll by, listening to some music, and having a chat with whoever sticks their head around the door on their way past. This morning's calm was punctuated with a few nervous moments when I came in the lab to find the plug for one of the machines had broken! This would have meant certain disaster for any sort of analysis to continue to take place for the rest of the cruise.

Luckily this ship is full of practical people, and several with some electrical skills too. Today, Nigel came to my rescue and managed to fix the plug so that I could get back on my way through my analysis. Only 36 more to go...

The seawater I'm analysing is collected from different depths through the water column. We use the CTD and Niskin rosette to collect the water. So far we have carried out 10 water profiles and sampling sessions. We try to sample every day at 11am, which marks the last event of our shift. As well as sometimes sampling more frequently to capture changes through time as well as in different locations. Each day I collect more samples, prepare them and then the following night I'm back in the lab, analysing them on my two machines... and there's that beep again, off I go...

Posted on [Thursday, May 24, 2012](#)

Written by Helen Findlay

Sgoil Lionacleit's blog Today's blog was written by Erin Warner, from Sgoil Lionacleit, Benbecula, about her experience visiting the Changing Oceans Expedition...

So there I was, sitting in the bottom of a little boat, that is bouncing around and feeling much too like I was in a roller-coaster for my comfort. It was too early in the morning, on the 20th of April, and we were on our way to the RRS James Cook. The James Cook is a research ship, that has been all over the world and it has now travelled to our humble little chain of islands to research the cold-water corals off Mingulay.

We eventually arrived, and after climbing up the rope ladder (much to my delight), we were ushered into a room full of complicated screens; given a safety briefing; then given a second breakfast!

Then we had a tour of the ship. First, we were shown what all the complicated screens in the first room were for: temperature, depth, mapping of the sea floor, current strength and direction and the radar, to name a few. After that, we were taken to the chemistry lab where they look at ocean acidification and measure the pH of the water. They let us breathe into test tubes of salt water to see how carbon dioxide changes how acidic the water is. This was really interesting, and fun! It also made me realise that it's like the entire human race is breathing into the oceans... a disturbing thought.

Then it was time for more coffee and a tour of the food stores. Well, I have never seen so much food in one place, except from in Tesco. Tins of this, that and the other, in every language, lots of fruit and veg, bread, dried everything and plenty of Nutella. What more could you possibly need? We surveyed the lounge (with a Wii and flat-screen TV), which looked better than my living room at home! And they have a bar! These scientist chaps live a life of luxury methinks!

Then it was off to the Captain's bridge. Again, a plethora of buttons and screens greeted us. We all took turns sitting in the Captain's chair and found a screen that, much to our amusement, told us we were lost. From here, we could see all of the equipment laid out on deck, including the ROV, which we got to watch while it launched.

We all rushed downstairs and stared at the screens as the ROV descended into the depths. Until, there on the screen was the first bit of coral. It wasn't brightly coloured and full of fish like the pictures you see: it was white and rather plain looking and yet so completely awesome! We saw the little polyps that the coral was made from, waving their tentacles to catch food. We saw starfish, a little brown fish and worms that apparently had teeth and weren't afraid to use them. We then got to go into the ROV control room. More complicated screens and funny buttons met us on arrival. We got to move the camera around and see how the arm worked. It was hard to believe that what we were seeing was more than a hundred metres beneath us at that very moment, showing us live footage from the sea-floor.

Then we were whisked off for a tour of the deck. There were big tanks where they kept samples of coral, brittle stars and worms. There were complicated things that took samples of the sea bed and that measures temperature, acidity and what not. Then we actually got up close and personal with the ROV. It was HUGE! When you saw it from the bridge, it looked fairly small, but it was easily the size of a land-rover!

Soon, we were whisked inside. We got to look at some of the animals they had photographed so far: sea urchins, lots of starfish and even an octopus! We then got to decorate some more polystyrene cups and a head to send down to the sea-floor so they would be crushed by the pressure and come up a quarter of the size. Again, so cool!

All too soon, it was time to go. Down the rope ladder and into the boat, the end of a great experience something I'll never forget.

(Thanks Erin!)

Posted on [Friday, May 25, 2012](#)

Written by Erin Warner (Sgoil Lionacleit, Benbecula)

Day 7: Bye bye Mingulay Today was the last day at the Mingulay Reef Complex for the Changing Oceans Expedition. For the next few weeks, the sight of land will be a distant memory, it will be nothing but sea! So, week one, where to start...

In many ways it seems like we have been at sea for months, we have gone from 21 scientists who see each other annually at meetings, to one big geeky family! In the 29 days we are at sea, we have a huge amount to achieve, and so, like many research expeditions, are running 24 hour operations. This means the scientists are split

in two shifts; the 'day shift' who work from midday to midnight, and then hand over to the 10 bleary-eyed scientists on the 'night-shift' (or A-team, as we like to call ourselves!). The handover period every 12 hours is always exciting; 10 tired but happy scientists try to update 10 hyper-caffeinated, recently woken scientists!

Lots of exciting science has been underway in the past week - equipment was tested and deployed. The ROV has been in the water daily, collecting corals, microbial samples and invertebrates, as well as deploying the Eddy lander (more about this in tomorrow's blog) and surveying the reef. In the chemistry lab, Helen has been busy processing her water samples and seeing how much carbon is in the water, while Geoff and Anne's hyper sterile area has made the room smell interesting! Seb and I have been measuring coral respiration, and Penny has been taking coral samples to look at their proteins. Next door in the cold room (7 °C, brrrr!), Georgios and John have sponges in chambers, Cova is watching the corals feed and Sarah is starting her coral experiment. There will be much more about all these activities in upcoming blogs.

Out on deck, a succession of equipment has been attached to various winches and deployed into the ocean, with lots of help from our amazing crew. From the CTD and SAPS have been taking samples for carbon analysis, to the SPI camera taking photos of the sediment, the crew have been busy attaching cables and making sure everything works before it hits water. Both gravity coring and box coring have commenced, bringing up mud to make our deck all messy (and to be preserved for analysis!). A mooring has also been deployed at Mingulay, which will allow us to collect data for the next year or so...

This week also had our first science crew birthday on the ship - my 30th! I was thoroughly spoilt, with a big chocolate cake courtesy of Wally the chef, as well as presents and a round of 'Happy Birthday'!. On my birthday, we also gained a stowaway, Bob the pigeon. He appeared in the CTD area, and has spent the last two days giving himself a tour of the ship, from the hanger right through to trying to sneak in the lab!

We have completed all we have time for at Mingulay, and following a stunning sunset over the Hebrides (so I'm told, anyway!), it's on to Rockall!

Posted on [Friday, May 25, 2012](#)

Written by Laura Wicks

Day 8: The Eddy has Landed Today's blog is written by Karl, from the University of Southern Denmark, all about 'Jackson', his Eddy correlation lander...

We are currently about halfway through our 280 nautical mile journey from Mingulay to Rockall, steaming at a steady 11 knots over the deep waters of the Rockall Trough. The scenic views of the islands south of Barra have been replaced by open ocean as far as the eye can see. The sun is shining and 'Jackson' (my 'eddy-correlation' lander system) is safe back on deck after having had his first ever adventure to the cold-water coral reefs off Mingulay. On top of that, the data looks promising! Life is good...

So what is this lander system all about?

The 'Aquatic Eddy-Correlation' lander is a new development in the aquatic sciences. Its main components consist of a 'Velocimeter' (an instrument that is able to measure the turbulence within the water) and a very sensitive oxygen sensor, that can sense even the slightest fluctuations in O₂ concentrations. These two signals are recorded simultaneously from the same spot around 15 cm above the seabed, 64 times every second. These data are then combined to give the flux of O₂ towards and away from the seabed. In our case we can therefore find out how much O₂ the cold-water coral reef ecosystem is respiring without interfering with the community in any way. This is valuable information since the conditions that the corals are exposed to at the seabed are not possible to replicate in the lab.

The ROV provides a fantastic platform for scoping out the best spot to place the lander. Once an ideal spot was found, the ROV positioned the lander on the seabed and returned back up to the surface, leaving the lander to record data. Watching the lander disappear from the ROV video feed for the first time, I couldn't help but feel slightly daft. It seemed irrational to abandon such an expensive piece of kit at more than 100 metres depth! Reminding myself that it is all in the name of science, and that Jackson is nothing but an amalgamation of expensive electronics and stainless-steel housings, I composed myself enough to become excited about the possibility of collecting new data. I felt more and more confident that we will be seeing the lander again when the ship's positioning system started to pick up a signal that was being transmitted from the beacon located on the lander frame. Needless to say, the lander was skillfully recovered by the ROV team the following day, intact and fully-functional. Now several hours of data processing await me, and then it's on to preparing Jackson for his next adventure off Rockall, this time at 800 metres depth! Wish me luck...

'Team Eddy' signing off...

Posted on [Saturday, May 26, 2012](#)

Written by Karl Attard

Day 9: The Coral Challenge Begins... Team Coral has a buzz of excitement, as their carefully collected corals have begun their ocean acidification and warming challenge.

But first, a bit about the members of Team Coral involved in these experiments. First up, we have Seb from Heriot-Watt University, multi-tasking to the max, just a blur of activity who only stops for tea. Then there's Janina from GEOMAR, our 'coral doctor', who's enjoying the supply of chocolate digestives, not available in

Germany! Next up, Penny from the University of Glasgow, who uses the term 'amazing' at least once an hour and is extremely excited by everything happening on the ship. And then there's me (Laura), the better half of the Heriot-Watt team!

Following months of preparation, our experimental tanks are now home to a selection of small fragments of *Lophelia pertusa*, deep-water coral from the Mingulay Reef Complex. These corals live a quiet life on the bottom of the ocean, they use their amazing tentacles to grab food floating past and use the energy from this food to create calcium carbonate skeletons. But all of this is likely to change within the next century. The vast amount of carbon dioxide (CO₂) in the atmosphere is increasing the amount of CO₂ in the oceans (ocean acidification). But why is this a problem for these out of sight animals? Well, these corals use carbonate ions which are in the ocean to make their skeletons. The increased CO₂ in the oceans is reacting with seawater to form carbonic acid, which releases hydrogen ions, reducing pH, and decreasing the amount of carbonate available to these corals. On top of this, the oceans are warming, and as yet we don't know what affect this will have.

So, the experiments we have set up will look at how the corals will respond, in the short term, to changes in the CO₂ level and temperature of the mini-oceans in which they live. Along with longer term experiments underway at Heriot-Watt, this will help us to determine whether corals can adapt to such changes, or whether it will be impossible for them to survive.

On a day-to-day basis, there is a lot to do to make sure everything runs smoothly in the 6 mini-oceans we have in the hanger. Lissie, also from Heriot-Watt, makes sure the temperature and CO₂ levels are stable, and the corals are happy. Penny, resplendent in safety goggles, is in a haze of liquid nitrogen as she takes small samples to look at the changes in coral proteins with these different conditions. Janina is measuring the coral's fitness and respiration- no running machines required! And Seb and I are looking at how the energy budget of corals change when they have to cope with different temperatures and CO₂ levels - so do they respire more or less? Do they eat more? Do they grow less? All will be revealed...

Posted on [Sunday, May 27, 2012](#)

Written by **Laura Wicks**

Day 10: Fish and Ships Today's blog is written by Rosanna from the University of Glasgow, about her fishy interests!

So unlike most of the other scientists on board the ship, my main interest on this cruise is not in the deep-water corals themselves, but rather in the role they play in providing habitats for fish. As we go deeper into the ocean depths, the amount of hard substrate available for animals to live on decreases rapidly, which means that there is mostly only mud for animals to live in. Places where there are rocky or biological reefs provide more complex structures for animals to live in, which means in turn that there is more space for lots of different animals to live there. For small invertebrates, deep-water coral reefs have been shown to support a much higher diversity and abundance of species than surrounding soft sediment areas, with the highest diversities being found in the areas of dead coral rubble that surround living reefs. However, the importance of deep-water corals for fish species is less clear and that's where I come in.

At the moment, I'm studying for a PhD at the University of Glasgow (Scotland) which is looking at the effects of human and natural factors affecting deep-sea fishes in a variety of different areas and habitats. So, what I'm interested in studying during this cruise is to look at how the coral reefs affect the distribution of different fish and whether the species found around the reef areas are different from those from the off-reef areas. This in turn will allow me to compare the results of this study to other studies I'm conducting on spatial patterns of habitat use in abyssal regions (4500m-4800 m) and also to a study on how fish react to oil-production structures on the shelf slope (1500 m).

Although I'm not able to conduct a specifically designed transect survey during this cruise due to the extreme time pressures placed on the ROV (everyone's got work to do with it after all), there is plenty of 'opportunistic' footage which I can use while all these other activities take place, and I've so far got some nice habitat surveys at Mingulay and across part of a reef at Rockall so far as well. The visibility wasn't too great at Mingulay since we're right in the middle of the spring plankton bloom, but now we're at the deeper site things are looking much better and we're getting some great footage of the reefs already, and there are fish everywhere!

Posted on [Monday, May 28, 2012](#)

Written by **Rosanna Milligan**

Day 11: Dissolving balls Today the blog is written by Seb Hennige (part of Team Coral) and is about clod cards (or clod balls as perhaps they should more accurately be named!).

As you can clearly see, there is a lot of life down at 860 m, and these animals form a very complicated food web. Understanding this food web is critical for many long-term studies, as until we know how carbon and nitrogen cycle through these ecosystems, we cannot predict what will happen in the future. Clod cards can provide the key to this.

These balls were painstakingly made over many months by Christina Mueller from the Royal Netherlands Institute for Sea Research (NIOZ) by growing algae and bacteria in very dense cultures with traceable carbon and nitrogen. These cultures are then concentrated further and mixed with gypsum to form the 'clod balls', which look like the fat balls you buy for birds over the winter. These balls are then suspended in a plastic cage and deposited on an area of reef rich with live animals such as corals, sponges, sea urchins and starfish.

These balls then dissolve into the water over the next period of days and the surrounding animals will eat the released food and take up the traceable carbon and nitrogen into their tissue. Depending on how much they eat and respire, different animals will take up more or less of the carbon and nitrogen. After six days, we will return to the sites where we left these clod cards and carefully sample some of these animals to see how much of the nitrogen and carbon they have taken up.

Once we understand these complex food webs a little better, then we can start to think about how they will be affected by future changes in ocean conditions. Fingers crossed that when we return in six days that the visibility is good and we can find them again.

Posted on [Tuesday, May 29, 2012](#)

Written by Sebastian Hennige

Day 12: Hidden creatures of the deep! Today's blog is written by Anne from the University of Hull, about the teeny tiny invisible creatures of the deep.

Look at the pictures of the amazing deep sea coral reef and think about what's living there. What mainly comes to mind? Coral? Fish? Sea urchins? Crabs? I bet you're not thinking about the microbes, but that's exactly what Geoff and I do! When we see a scene like that we're wondering what bacteria, fungi and viruses are present there and what they're doing. Just like humans have microbes all over their insides and outsides, the same is also true of corals and other marine creatures. These microscopic organisms can affect their hosts in a number of ways, ranging from helping to keep them healthy (think yakult!) to causing disease. However, we know very little about the identity or function of microbes in these deep, cold water coral reefs, largely because they're so difficult to study.

The main problems are that the microbes on the coral aren't always very well stuck to them and the sea is full of other microorganisms so if coral is just pulled up to the surface, many of the microbes that live on it will be washed off and replaced by others. To get around this problem Geoff has designed and built a special sampler (see photo). This consists of six canisters with lids held on by super strong magnets which we fix to the remotely operated vehicle (ROV) and send down to the seabed. Once there, the right robotic arm of the ROV removes the lid of one of the canisters whilst the left arm picks up the 'slurp gun' - a device like a really strong vacuum cleaner. It then uses this to Hoover up a few little pieces of coral and puts them in the canister. The right arm then puts the lid back on and seals it tightly shut. By encasing the coral samples like this, we protect them from contamination so when the ROV returns to the surface, the microbes are still on them just as they were when they were originally 800 metres underwater. A huge amount of time and effort was put into designing and building this sampler and before this cruise it had never been tested under such extreme conditions, so the first dive was pretty nerve racking! It worked like a dream though and watching the ROV operators getting such great samples for us in such a technologically advanced way has been an amazing experience!

Once the ROV's back at the surface, we remove the canisters and begin the challenging task of studying the microbes they contain. Classically, people have done this sort of work by growing them in petri dishes and tubes but this approach can lead to a very biased view of what was actually originally present as not all microorganisms will thrive in such artificial conditions. For this reason we use techniques that don't rely on growing anything at all. Just like the police use DNA evidence to see who was present at the scene of a crime, we use very similar techniques to find out which bacteria were on the coral.

We'll also use a method called fluorescent in situ hybridisation (FISH) which uses special chemical probes which glow when they bind to bacteria so we can look at the coral under a microscope to pin-point their exact location. Unfortunately these techniques take a long time and require very expensive specialist equipment that we don't have on the boat. This means that for now we're spending our time preserving the corals so we can look at them once we're back on dry land and finally understand more about these often ignored but very important little organisms

Posted on [Wednesday, May 30, 2012](#)

Written by Anne Cotton

Day 13: Underwater robots On this cruise, a great deal of the research relies on our underwater robot (the ROV), and the crack team of pilots that spend their days sitting closely together in a metal container!

Let me introduce you to the team. First up there is Will, the ROV supervisor, who makes sure everything is running smoothly and is on hand to fix any problems which arise. Will has extensive experience with ROVs, from working at Woods Hole Oceanographic (WHOI) to freelance work at Southampton with ISIS. He constantly amazes us with his experiences, from 3D filming from helicopters and seeing erupting underwater volcanoes, to finding the Liberty Bell space capsule.

Then we have the ROV pilots: Paul, a New Yorker who keeps everyone entertained with his jokes. A citizen of the world, he is now based in the sunny shores of Miami. Richie has a background working on ROV sensors, and has achieved his ambition of ROV-based science expeditions on this, his first science cruise! When he's not in the command unit or ROV area, he is regularly seen around the ship taking amazing photos. Martin (top photo) is the Willy Wonka of the team, supplying sweets to the guys, which I'm sure helps the tense atmosphere when something unexpected happens!

Finally we have Dave from the National Oceanography Centre, our ISIS pilot who is learning all about the Holland I ROV we have on board. Dave has a way with words, wanting to work with ROV exploration because it is the 'pinnacle of ocean exploration', and describing Antarctic hydrothermal vents 'like factories with smoke billowing out!' These guys combine their experience to ensure that the scientists are happy, from collecting near bed multibeam data, to carefully sampling corals, sponges, crabs, brittle stars and even microbes!

The process of ROV deployment and recovery is probably the most stressful part. First, the ROV frame is moved out and over the ocean, using the control panel on deck. The winch then slowly deploys the ROV, still attached to the tether management system (TMS). Once it is at 100 m, the pilot in the ROV unit takes over, sending the ROV and TMS down to just above the reef. The TMS then releases the ROV, just like a toddler on reins, so it can explore the mysteries of the deep. From here, the pilots control its every movement from the command unit, using the amazing 'mini-arms' to control the ROVs robotic arms, or manipulators. While this is all going on, the ROV pilot and co-pilot are joined in the command unit by two scientists, who get to choose their samples, control the HD camera and keep a running commentary as the adventure unfolds.

Posted on [Thursday, May 31, 2012](#)

Written by Laura Wicks

Day 14: Up close and personal with corals Out in the North Atlantic, conditions have changed - the swell is up and we have been busy securing everything after 2 weeks of calm seas. ROV operations have continued throughout the afternoon, and the night team are now about to embark on a box coring campaign in the rain!

But first, today's blog is written by Penny from the University of Glasgow, about coral feelings!....So many of you will have heard scientists talking about global climate change and ocean acidification, but what exactly do we mean when we talk about this? And why are we particularly interested in it on this expedition? Global climate change sums up a whole list of things affecting our environment. Scientists believe these changes have been caused by human activities which have led to an increased level of CO₂ in Earth's atmosphere. If we look back in the past we can see that the Earth's climate has been through some major changes. The difference between past changes and modern day climate change is the speed of that change and scientists are worried that animals and plants will struggle to adapt fast enough to the new conditions.

Increasing temperature and [ocean acidification](#) are two factors that have been highlighted as areas of concern for the animals and plants that live in our oceans. Deep sea coral reefs provide a home for thousands of marine animals and act as a nursery ground for many important commercial fish species. As a member of team coral, I am part of the experiment investigating how cold water corals may respond in the future to increased temperature and ocean acidification. Ideally we would be able to ask the corals how they were feeling about all these changes to their habitat; however scientists are yet to master the language of coral! Therefore we need to come up with ways to find out how the coral is 'feeling'. Ok, so here is the science; I look at the response of corals to environmental changes at the molecular level. All the processes we carry out on a day to day basis, including eating, breathing, regulating our body heat and growing, are controlled by proteins. For example, when we breathe our body transports oxygen from the lungs around the body using the blood. The main component of our blood, and the thing that does all the work, is a protein called haemoglobin. When our body experiences a change in environment our body is able to produce more or less of particular proteins to cope with these changes. If I was climb up a mountain to a very high altitude where there is less oxygen in the air, my body would produce more haemoglobin to help me cope with this change. The proteins used by the corals act in a similar way to changes to their environment. We can look at changes in the concentration of particular proteins to assess how important coral processes, such as calcification, may respond in the future to increased temperature and ocean acidification. By looking at the corals in this way, we can start to better understand how and which processes important to the coral, will be impacted by climate change.

Posted on [Friday, June 01, 2012](#)

Written by Penny Donohue

Day 15: Capturing Carbon and Corals The Changing Oceans expedition has passed the halfway point, and everyone is optimistic that all our aims will be achieved. It's pretty rocky out at Rockall at the moment, the waves are up and ROV operations have been postponed. Luckily, there is other equipment that we can deploy when the seas are a bit choppy so overnight we have had the [moving vessel profiler](#) in the water. But first, today's blog is written by Rowan from Heriot-Watt University about cold-water corals, from an engineering perspective.....

Hello and nice to meet you. I have been asked to write a small piece for today's blog so I thought I would tell you a little about my research. Though I hail from Ireland, I feel quite at home in my present position as a postgraduate researcher with Heriot-Watt University's School of Engineering and Physical Sciences. This specialty is, as the name suggests, where engineering meets the physical and, in my case, life sciences.

As a marine biologist, I have always held a deep fascination for learning about natural biological systems and using information from these processes to look after and repair damaged areas of our planet. It seemed natural for me to gravitate towards the concept and engineering of carbon capture and storage (CCS) as a way to deal with climate change. CCS is, in brief, capturing carbon dioxide and other flux gases from the source of combustion (e.g., power stations, fertilizer & concrete manufacturing) and transporting it to a storage facility on land, at sea, or even beneath the seabed.

My research is concerned with the environmental impact(s) of this stored CO₂ on marine creatures and the surrounding ecosystems. If this CO₂ store were to leak, either during or post injection, it could have rapid and immediate effect on the critters that live near the reservoir. As the name of our expedition denotes, the oceans are changing. One aspect that is currently being altered is the acidity of the sea. If too much CO₂ enters the world's oceans then it could drastically alter the pH of the water which is normally 8.1 in the ocean to anything from 6.5 to 7.8. To put this in perspective your stomach has a pH value of about 1.5 to 2 and orange juice a pH value of 3.5. Overall, changes in pH could have major effects on marine species, presenting a new challenge to their already perilous existence. While this may be short term from 7 days to 2 months or more it has many consequences for carbon cycles, marine species, ecosystems and us.

I am investigating the effect(s) of rapidly lowered pH on deep water coral species. Obviously, it is key to avoid a possible leak in the first place. However, if it does happen, we need to study the impact on surrounding marine communities, so we will have some idea of what will happen to them and their ecosystems. It is my

hope that the results of this research will help guide the development of policies that impose regulations on the type(s) of technology required to safely manage carbon sequestering programs like CCS.

Posted on [Saturday, June 02, 2012](#)

Written Rowan Byrne

Day 16: Half-way through and the weather turns Today's blog is written by the Principal Scientific Officer, Murray, as the weather gives him time to pause.....Today the Atlantic Ocean is roused with winds gusting to Storm Force 8 and a rolling swell of between 4 and 6 m. It's too rough to put any equipment into the sea so for the moment no more ROV dives are possible and we are running acoustic surveys of the seabed that will help us understand how coral carbonate mounds are formed.

Given the weather, and since we have passed the half-way point of the 2012 Changing Oceans Expedition, it's a good moment to think about what we've achieved and why we've all gone to sea for a month. The evidence that global climate is changing is overwhelming and the vast majority of scientific opinion supports the view that these changes can be traced back to the release of greenhouse gases since the industrial revolution. Among these gases carbon dioxide released from burning fossil fuels is the most significant contributor to global warming. Something approaching a third of the CO₂ released by human society has dissolved in the oceans causing [ocean acidification](#) at a rate faster than any seen in geological history.

The Earth's rapidly changing climate sets the stage for our research on the Changing Oceans Expedition. As this blog shows, the research teams on board are all busy tackling the often daunting task of trying to assess how complex biological systems will respond to ocean acidification.

Perhaps the greatest feature of spending a month together at sea is the chance to work in teams tackling different aspects of the same problem. Already we're seeing new lines of research spring up between people on board and entirely new studies and measurements are being carried out – some developed from ideas and discussions since we set sail.

Ecology isn't a neat and tidy subject and understanding what controls and modulates ecosystems is a huge challenge. The Changing Oceans Expedition is one of the most ambitious attempts yet to understand the functional ecology of cold-water coral systems. Without this understanding we cannot predict how these ecosystems will respond to global climate change. In essence this is the thread that links all the different teams and research projects on board.

As I write this our ship-board experiments continue despite the weather, the occasional roll of the ship and the home-made crowns many of the researchers on board are wearing today to celebrate the Queen's Diamond Jubilee. More about our Jubilee celebrations tomorrow...

Posted on [Sunday, June 03, 2012](#)

Written by Murray Roberts

Day 17: Pumps and Pageants As many of us were missing the Queen's Jubilee celebrations (and 4 day weekend!) back home in Blighty, we decided we should honour the occasion on board our Royal Research Ship.

Being mainly prepared for science, not arts and crafts, we had to use our imaginations! So out came the waterproof marker pens (designed for writing labels on tubes) and aluminium foil, and the scientists found their creative sides, designing crowns and hanging bunting throughout the ship. Everyone got into the task; Americans, Maltese, Spanish, German, Finnish, Belgian, Chilean and Irish joined with the Brits to mark the occasion. Then, while the sun came out over the Atlantic, those of us on the night shift wound down from their grueling shift by watching the people of London turn out in the rain to watch the Jubilee pageant.

Ok, onto the science. Overnight, we have been running a CTD/SAPS campaign. As in an earlier [blog](#), Helen has been using water collected by the CTD to analyse the carbon chemistry and other oceanographic parameters, like temperature, salinity, and chlorophyll. Attached to the CTD frame, we have a SAPS - Stand Alone Pumping System. The SAPS is basically a big pump attached to a filter rig with a delayed timer - it means we can send the pump to whichever depth we want and switch it on without being there.

But why exactly do we want to do this? Well, we use the SAPS to look at the amount of particulate organic carbon (coral food) that is reaching the reefs. The pump records how much water flows through the filters, and following laboratory analysis of how much carbon is on the filters, we can calculate how much carbon (food) the hungry corals have access to. This information, combined with surveys of the reef and CTD data, can help us understand why the corals live where they do, and what any future changes in climate and currents may have on these ecosystems.

Posted on [Monday, June 04, 2012](#)

Written by Laura Wicks

Day 18: The Oily Bits There were big sighs of relief all round this afternoon as the weather improved and the ROV got back in the water. But now for something different. In the morning, the night shift were treated to a tour of the engine room by the Chief Engineer. Nigel from CEFAS tells us more.....

The RRS James Cook is a truly wonderful piece of modern engineering. At one end of the spectrum you have a ship which floats and man has been making these for thousands of years. At the other end of the spectrum you have a massively complicated piece of engineering that not only floats but also provides water, electricity and all the services required to support life and the complex needs of a modern research vessel.

Today we were given the superb opportunity to have a look around some of the areas below deck where the lesser known species of Marine Engineers live. To maintain the creature comforts for 54 people you need lots of water, fuel (to make electricity) and food. Our guide was Bob, the Chief Engineer with years of experience. After a brief safety talk, we started in the main control room, home to the controls for most of the machinery and generating plant. A lot of the controls on the Bridge are duplicated here, so that at any time it is possible for the engineers to take control, if needed!

We proceeded through the various spaces that make up the 'heart' of the vessel. For a lot of the scientific work that the RRS James Cook undertakes it is necessary for it to hold station, i.e. the boat needs to be geographically stationary. This is possible because of a system called Dynamic Positioning (DP), basically this is a computer that is able to control not only the main propulsion but a variety of other propulsion systems. In total, the James Cook has two main propellers, two stern (tunnel) thrusters, one bow (tunnel) thruster and one retractable azimuth bow thruster. These are all controlled by the DP to maintain the vessel in an exact stationary position. This ensures both safety and efficiency of deck operations. As mentioned above, we needed a lot of fresh water for everything from people to take a shower to making the essential cup of tea. The boat can hold up to 200 tonnes of water but still needs to make up to 9 tonnes a day to save costly port calls. This is made by a low pressure evaporation plant, which is then chlorinated before entering the storage tanks.

To keep all the various machinery running we need fuel and quite a lot of it. We have the ability to carry over 730 tonnes, this fuel is warmed slightly and cleaned before being used to power the engines. After passing through the main engine room, switchboard room, aft and fwd thruster rooms, compressor room, boiler room, engineers workshop and various other nooks and crannies we were returned to daylight like Hobbits coming out of caves. Now the techy and number bits: Date of build: August 2006 Displacement: 5800 tonnes Dimensions: 89.5 m x 18.6 m, 5.5 m draught. Main Engines: 4x Wartsila 9L20 engines coupled to 1800KW generators, these produce 3 phase 690VAC which is mainly used for the prop motors but also converted to 415V 3 phase, 230V and 110V for distribution throughout the vessel. Propulsion Motors: 2 x 2500kW electric motors Bow Thruster: 900kW Azimuth thruster: 1400kW 2 x Stern thruster: 650kW and 800kW. Clean Power: 2 x 415V Motor Generator sets, 2x 230 MG sets.

Posted on [Tuesday, June 05, 2012](#)

Written by Nigel Lyman

Day 19: It's gettin hot in here... The swell continues to prevent any ROV deployments, but everyone's spirits are up, particularly after learning that we appeared on the BBC Jubilee Show in our home-made crowns! The science continues, as there is also equipment that we can deploy in these conditions, and there are many on-board experiments taking place with the corals and sponges collected from the seamount.....

Today's blog is written by Sarah from Heriot-Watt University in Edinburgh, all about warming up corals!

Think about the reaction of the human body when we enter a very cold room? We all know that we will get freezing hands and feet, but we also breathe faster to compensate for the loss of energy. This is because our bodies are trying to heat up and perform their usual processes under freezing conditions. Now interestingly, the same happens with corals, but in response to warmer temperatures!

We are out in the middle of the North Atlantic Ocean, and we share this spot with deep-sea corals. The corals live 600-800 m below us and are amazing in their structure and diversity, as we see most days on the High-Def screen, pictured by the ROV cameras. We assume that these corals are comfortable in their 9°C, cold environment; we can see their polyps extended and their tentacles waving in the current. It is thanks to Helen and the CTD array that we know all about the conditions on the reef, from the temperature and salinity to oxygen levels!

As we know, global warming is happening on our planet, and the ocean temperature is increasing. the question that I am trying to answer is: Will the cold-water coral *Lophelia pertusa* increase their metabolism and 'breathe' differently when the oceans warm? Or can they adapt to these warmer conditions? Fingers crossed it is the latter!

In my project, I am comparing how corals respond when the seawater temperature is increased slowly, at a medium rate, and rapidly up to 12°C. This is a relatively large temperature increase for these corals, who would have only experienced small fluctuations of less than 1°C. My corals are living in tanks in the cold-room that we have on board the ship. The room is regulated to 9°C to ensure conditions comparable to the deep sea where we collected them – also means we have to wrap up warm when working in there! I am using heaters in each of the tanks to steadily warm up the tanks and control their level. Every third day, I measure the respiration rate of the corals using an optode system and specially designed chambers. I can then compare any changes in coral metabolism that have occurred, and see if the rate at which we change the temperature affects the corals response. Research so far on both tropical and cold-water corals has shown they are very sensitive to stress, particularly temperature changes, seen in the mass coral bleaching in the tropics. Even though cold-water corals are out of sight, 600 m below us, we still need to work out how they will respond to future changes in temperature, and protect these amazing creatures!

Posted on [Wednesday, June 06, 2012](#)

Written by Sarah Fitzek

Day 20: A sneak peek at life on board... Following another successful ROV dive, in which we saw squid, jellyfish, huge crabs, massive anemones and beautiful fields of the corals *Lophelia* and *Madrepora*, it was time to leave Logachev and steam north. Our destination: The Pisces 9 site where pioneering dives by John Wilson in 1973 gave us video and still images of *Lophelia* reefs on the Rockall Bank 350 miles offshore.

The 13-hour steam gives me time to tell you a little about the 'floating travel inn' that is the RRS James Cook! The ship can be home for up to 54 people for more than a month, so as well as being well equipped for all the science we will do, it also gives us a little bit of home.

So lets start at the bottom. On the main deck we have the accommodation - cabins and shared bathrooms for each scientist and technician. Being low down in the ship makes sleeping easier when it gets rough, although there can still be a fair amount of rolling around when the swell is up. Downstairs we also have a gym, which becomes a bit of a necessity with all the nice food we get - especially since jogging round the ship takes all of a minute! There's also a little bit of luxury downstairs, with our very own sauna - perfect for warming up after hours on deck sieving benthic samples in the wind and rain.

The upper deck is where all the science happens. First up we have the dry lab and the plot, where plans are made with the captain every morning, and the day shift gather around the screen during ROV dives. There can be some tense moments around the TV, particularly where the manipulators are deploying or retrieving expensive equipment! The dry lab is an IT geeks heaven - computers fill every space, bringing in information from the various pieces of equipment deployed from the ship. Next-door is the chemistry lab, Helen's home for 12 hours a night, where she analyses her water samples. She has frequent visitors; Team Microbe process their samples, Team Coral take measurements of coral health and Team Sponge study their samples under the microscope.

Heading towards the back of the ship, we have the cold-room and the wet lab. Not actually wet, but a place that equipment can be prepared. Out through the watertight doors, we have the hanger, which houses our 'mini-oceans', large tanks holding a myriad of sea creatures. This is also the space where larger equipment is prepared for deployment - especially when it's raining and windy on deck!

Up one level on the mezzanine deck, we have the galley and mess (kitchen and dining room to land-lovers!), as well as the TV room (complete with Sky box), Library and the Bar. At precisely 7.20am, 11.20am and 5.30pm, the mess comes alive, as hungry scientists descend on the chefs to fill their empty bellies. The chef's (John and Wally) have one of the most important jobs on the ship - hungry scientists are grumpy scientists. So its a 5am start for John and Wally, planning the day's meals and cooking up a storm. Between 4 and 8 tonnes of food are craned onto the ship during mobilisation, and special fridges keep the fruit and veg fresh for up to 3-4 weeks.

Keep going up the stairs and there is crew accommodation on the boat deck, and then more cabins on the Forecastle deck, including the PSO's suite! Finally, right at the top is the bridge, a flashback to Star Trek, complete with Captain's chairs and touchscreen controls (although disappointingly, no big wooden steering wheel!). The view from the top is stunning, from the huge waves on rough days, and clear skies and wildlife on sunny days. Fingers crossed for more of the latter!

Posted on [Thursday, June 07, 2012](#)

Written by [Laura Wicks](#)

Day 21: Sponges of the deep... Yesterday's dives at the [Pisces](#) site revealed a plethora of stunning white *Lophelia* - a great result, since we were not sure what we would find! Although there are still images and videos from John Wilson's 1973 dive, very little research has been conducted in the area in the past 40 years, so we were all very happy to see the white polyps waving in the currents.

Another animal, which we are always happy to find are deep-sea sponges, and there amazing abundance means we are never disappointed! So, today's blog is written by Georgios from the University of Aberdeen, about his spongy specimens of the deep.

Deep-sea sponge grounds are important deep-water ecosystems. They provide structural habitat, which is home to a great number of species, as well as acting as nursery grounds for commercially important fish. Importantly, sponges are thought to be a source of bioactive compounds, which can be used to make new drugs. Despite these major characteristics, deep-sea sponge grounds have been overlooked for many years. Their presence in areas of intense human exploration (i.e. gas / oil drilling and trawling) makes them particularly vulnerable to destruction. But, over the past few years, conservation of these important species has become a priority, which makes studies on the structure of these ecosystems essential.

Sponges are mainly active filter feeders, which means that they pump seawater through their body and remove particles that are in the water that they can use as food, before pumping out any unused excess. Sponges can also play host to symbiotic bacteria, a relationship where the sponge gains important nutrients from the bacteria, and in exchange the bacteria thrive in their sponge tissue home. Recently, it has been shown that sponges with symbiotic bacteria can also use dissolved organic carbon as a food source, which is really important when looking at the role of sponges in the deep sea food web.

In this cruise, we have conducted on board experiments on the feeding and respiration of sponges from the Mingulay Reef Complex and Logachev Mounds, where we found them were attached to dead coral fragments. The sponges were placed in incubation chambers equipped with stirrers and optodes (which measure oxygen levels). In the chambers, they were fed with various food sources (glucose/ammonium, microalgae, bacteria), which were labelled with carbon (13C) and nitrogen (15 N) isotopes. After 24 h in the chambers, our samples were frozen so that we can analyse how much of these isotopes were taken up into the sponge tissues.

These experiments will (hopefully!!) provide us with important information about the uptake and turnover of each type of food source. In this way, the role of sponge assemblages in carbon cycling in the deep oceans will be illuminated.

Posted on [Friday, June 08, 2012](#)

Written by Georgios Kazanidis

Day 22: Rowing on Rockall Last night, the scientists aboard the RRS James Cook has the once-in-a-lifetime (probably) opportunity to see Rockall, as Captain Bill took us via the the Rock, on our way to the Hebridean Seamount. For those of you don't know (and many of the scientists are among you in the dark), Rockall has been referred to as "the most isolated small rock in the oceans of the world", the UK's furthest outlier. Unfortunately the British weather failed to surprise us, and all we saw was a slightly darker grey blob, amid the grey sea and sky. After all that excitement, it's time for today's blog, written by Geoff Cook, our resident American giant...

It's just past 04:00 on the morning of June 9 and I recently finished getting a bit of exercise on the ship's Concept II rowing machine, or ERG. For those of you who have never had the "pleasure" of experiencing this modern instrument of torture, you should know that it is world-renowned for inflicting severe pain in extremely short periods of time. After collecting and processing samples, and with more work to be done before getting some rest, I foolishly decided to blow-off steam by raising my heart rate. Being too tall to run on the ship's treadmill without decapitating myself, I had no other option but to hop on the ERG.

One of the psychological benefits I derive from rowing is that it offers the ability to retreat into one's mind, thereby escaping the pains inflicted by both the ERG and our fieldwork. As I bumped along, feeling each swell in the ocean roll beneath me, I began waxing nostalgic about my days as an undergraduate when I rowed competitively. The coordinated exertion between me and eight companions— I am including our coxswain in this headcount—was the result of a mutual understanding that we were all racing against time, the competition and, in many ways, ourselves. I soon found these memories helped me to recognize a few parallels about the type and degree of teamwork I have witnessed since joining the 2012 Changing Oceans Expedition. An aspect of group-work that I have always found fascinating is the ability for multiple individuals, regardless of any pre-existing relationships, to focus their efforts towards achieving a common goal. When properly motivated and directed, the combined effort of 2, 4, 8, or even 54 people can transfer a remarkable amount of energy to meet the demands of remarkable challenges. Studying coral reef communities that live 1000 meters beneath the waterline in the northeastern Atlantic Ocean presents, in my humble opinion, a remarkable challenge.

All monetary expenses aside, these biological systems are too remote, too deep, and too complex for a single individual to achieve even a modest degree of understanding in a realistic time span. Developing an accurate and focused picture of how these communities will respond to the pending threats of global climate change can only be achieved by launching a multi-faceted, synergistic research program like the 2012 Changing Oceans Expedition. This requires enlisting the help of numerous individuals with a diverse array of expertise. In other words, many hands make light work.

The inherent limitations of studying life in the deep sea seem to be one of the mutual understandings that we (i.e., the crew of the RRS James Cook, the ROV team, and the international collection of scientists) all share. As a result, a common thread seems to have emerged that weaves cohesiveness through the patchwork of activities being conducted during this cruise. What I find most impressive is that this thread appears to have arisen organically (i.e., it was not demanded by anyone except, maybe, by ourselves).

In many ways, this mutual understanding extends beyond the confines of the RRS James Cook, reaching across oceans as well as political and cultural boundaries. Many people have contributed to the success of this research cruise and they all deserve thanks. So, my sincere thanks go out to the ship's crew, the ROV team, my colleagues, and everyone else (Happy Birthday Love!) who has contributed their time, energy, and belief in this expedition. But letters of recognition and key deliverables can be ephemeral. Perhaps using the results of our inquiries to enact positive change is a more appropriate way to give back or, better yet, give forward. While establishing goals that aim to preserve environmental legacy for our future generations is laudable, actually achieving these goals may be the best thanks we can offer. Though I cannot be certain, I believe this is another thread that binds us all.

Posted on [Saturday, June 09, 2012](#)

Written by Geoff Cook

Day 23: The Coral Doctor explains all... Since our early morning arrival at the Hebrides Terrace seamount, and Helen's excitement about getting water samples from nearly 2000 m, the ROV has been busy surveying the seafloor. The coral biologists among us weren't too excited about the swaths of mud in every direction, but each to their own. So, today's blog is written by one of those coral biologists, Janina Buscher from GEOMAR...

As a member of Team Coral on board the RRS James Cook, I am involved in the work that goes on outside with the experimental tanks in the hanger of this ship, related to future scenarios of climate change conditions. As already explained by [Helen](#), [Laura](#) and [Penny](#), we are investigating the question of what might happen to the animals in our oceans – especially the most abundant cold-water coral *Lophelia pertusa* – when the ocean warms up and gets more acidic. Ocean warming and acidification caused by elevated atmospheric carbon dioxide concentrations is of greatest concern in higher latitudes and in cold deep waters. This is because carbon dioxide, which is mostly absorbed by the ocean from the atmospheres, dissolves more easily in these areas and is, hence, expected to have a stronger impact on the animals living there.

As a “coral doctor” – as I was called in an earlier [blog](#) – I am specifically interested in the health of the corals. I am trying to find out how fit the corals are and how this will change in response to more acidic waters or higher temperatures or even both in combination, like is expected to occur by the end of this century. So, how am I doing this? Well, I am analysing the fitness of the corals as well as the respiration rates. But unlike a human doctor, who would probably make you pedal on a training bike to measure your pulse after exercise, I estimate the coral’s fitness via a molecular method and the respiration rates via oxygen consumption.

Measuring fitness on a molecular basis is possible in different ways. The way I am measuring is by examining the amount of Ribonucleic acid (RNA) compared to the amount of Deoxyribonucleic acid (DNA). RNA is the actively transcribed part of the genetic information, which is translated into [proteins](#) that are needed for all the corals metabolic processes. Therefore, the ratio of RNA to DNA shows how much of the genetic information is actually active, which gives us a hint of the coral’s fitness. The higher the RNA content, the more active and so the fitter they are. As I can’t analyse the RNA on board, I have to preserve the tissues in a specific solution for later analysis in my laboratory in Germany. So that I can compare how the fitness of the corals changes in response to future ocean acidification and warming, I fix the coral tissue of a few polyps before and after being incubated in the different experimental conditions.

I also have coral colonies from the Mingulay Reef Complex, in which I am measuring how much oxygen the coral fragments respire in a specific time span. I can do this in small sealed chambers with oxygen sensors. After I measured the respiration in all of the fragments, I incubated them for 10 days in the different climate change scenario treatment tanks. As I write this, I am currently halfway through my second period of respiration measurements. By measuring respiration rates in all fragments again, I can see if *Lophelia pertusa* breathes more under acidified or warmer water conditions, or if they might be able to acclimatise to oceanic conditions that are predicted for the future.

Aside from the corals, I am happy to see that the old-school gas-mixing pumps that enrich two of the treatment tanks in the hanger with a CO₂-air gas mixture of about 750 μ atm (predicted value for the end of this century), work pretty well and do their job quite precisely. The deep water pump, which I brought from Germany, purrs quietly ahead and regularly delivers water from deeper water layers, so that the corals get water similar to their natural environment. Above all, I am happy that Germany won the game against Portugal yesterday ;) and if everything goes on like this, the cruise will be completely successful!

Posted on [Sunday, June 10, 2012](#)

Written by Janina Büscher

Day 24: Mapping the cold-water coral landscape The cruise is reaching its final stages now, and the team have collected a number of samples for the ocean acidification experiments. In addition we have placed equipment on the seafloor and carried out visual observations along transects. But how do we know where exactly to go? What kind of environment do our coral samples come from? In today’s blog, Veerle from the National Oceanography Centre, Southampton, talks about the technology we use to do this....

Understanding the surroundings of the coral sites and the spatial structure of the habitat is important for the final interpretation of the experimental results. It is also important in its own right, because marine habitat maps are increasingly used as the main source of information to support decisions about marine protected areas and conservation of endangered species.

So how do we go about creating a map of the seafloor and coral habitat? Unfortunately, visual light doesn’t travel very far in water, so we can only use photography and video at very close distance to the seabed. However, it is (currently) impossible to video or photograph the entire world’s ocean floor – this would take hundreds of years! Instead, the tool of choice for mapping the seabed is sound: by using different types of echosounders and different frequencies, we can map the morphology and reflectivity (which gives an indication for the sediment type) of the seabed.

A single beam echosounder measures the time between a sound signal being sent from the ship and the echo from the seabed to coming back, and converts this into depth below the vessel. This is continuously repeated while the ship travels on, and results in a profile of the seabed plotted on the screen. A multibeam echosounder basically does the same, but has a whole fan of acoustic beams going out from the vessel. The seabed depth is measured for each of these beams, and by repeating this ping after ping, a 3D morphological image of the seabed is created (see Figure). In addition, the strength of the echo in each of the beams tells us something about the seafloor type, with strong echos from rocky or gravelly substrates, and weak returns from a muddy seabed.

Unfortunately, there is one trade-off: due to the geometry of this fan of beams, and the absorption of sound in the water (less than the absorption of light, but still), mapping in deeper water needs a lower frequency sound source and results in lower resolution in the final map. Typically when working in 1000m water depth, the pixels in the map represent about 25x25m patches on the seafloor, while in ca. 100m water depth this can be reduced to 2.5x2.5m.

So, to get a better picture of the coral reefs, we have to bring the multibeam system closer to the seafloor, which we do by putting a system on the ROV! Flying the ROV at around 30m above the seabed, we create ultra-high resolution maps, with pixels of around 0.5x0.5m, although we cover less ground in the same time. It’s a real challenge for the pilots as they have to fly in the dark: at 30m altitude we cannot see the seabed! It may come across as a fairly tedious activity, slowly moving along the survey lines at a speed of 0.4kn, not seeing very much, but I find it fascinating to see the map being created on the screen, line after line! Combining this information with the video interpretations will provide full-on habitat maps of the coral landscapes.

So far we only have been able to map one area with this technique during this cruise, although we have used the ship-board multibeam systems in several occasions already. The results of the ROV mapping provide unprecedented insights in the shape of the coral reefs, and we hope the weather will be kind enough to us to allow a few more detailed maps to be made!

Posted on [Monday, June 11, 2012](#)

Written by Veerle Huvenne

Special edition: An undergraduates' perspective.... Today we have a special point of view, written by Lissette from Heriot-Watt University...

You don't usually expect to find an undergraduate on a research vessel among a 20-something strong team of scientists. Nevertheless, as my dissertation focused on the biodiversity of the cold-water coral reefs of Mingulay, I have managed to incorporate myself on the James Cook for everyone's delight and help. My role as a research assistant means I get to help everyone on the famous night shift.

My nightly chores are variable, giving me the fantastic opportunity to be involved in everything that goes on during my working hours. One example of this is helping Helen with CTD water sampling, as well as sample processing for studying the water column and the carbonate chemistry of the visited sites. I have also been involved in helping [Team Coral](#) with studies relating to ocean acidification and cold-water coral physiology, as well as the [protein](#) work conducted by Penny. Additionally I've helped with benthic sampling, which means sorting and sieving mud that is brought up by the box core.

Box coring also resulted in us getting some solitary corals on board. This has allowed me to carry out a small study of my own, measuring this yet-to-be identified species' respiration rates and possible changes in these in response to exposure to elevated water temperature in the "mini-oceans". On top of this, due to Helen being busy with her own work, I was able to help with another short-term study on sea-urchins, to look at their response to varying CO2 levels, so we can get an idea of how they would respond to ocean acidification.

As this cruise is mostly filled with a bunch of young scientists, such as PhD students and post-docs, everyone has been keen to share their knowledge and reasoning behind their experiments while teaching me different sampling techniques. I have also learned a lot about how academia works and about the endless amount of things that can be researched and that if you're not sure how to tackle your research, a technician will be able to help you! On a wider scale, the science occurring on James Cook is truly multi-disciplinary, therefore providing me with a wholesome comprehension of our oceans as well as taking me beyond marine biology (which is what I've studied) to oceanography and the technical processes such as exploration by the ROV and seabed mapping. While talking about the ROV, it must be said that the scenery it has provided us with, through its cameras, is phenomenal, allowing us to see the beauty of the cold-water reefs and the rich biodiversity they support.

As a conclusion I must admit my life on board has been quite exciting. This once in a life-time opportunity has taught me a lot, inspired me in relation to my future scientific path and provided me with a lot of knowledge on the state-of-art environmental issues and how we can tackle these through science!

Posted on [Monday, June 11, 2012](#)

Written by Lissette Victoreo Gonzalez

SPI-ing on reefs and seamounts Silvana Birchenough from Cefas continues to report on the SPI work conducted during the expedition.....

Nearly time to return home and I am delighted to report that our SPI camera has been a great success. We have been able to take some fantastic images of the fauna at the Mingulay Reef, Banana Reef and Logachev mounds study sites. This has included taking images down to a depth of 1000m at Logachev. Most of our previous SPI work and collection of images have been taken at 35-45 m depth. This is the first time SPI images have been taken in these areas, which make it very interesting for us to see in real time some of the fauna and sediment types. This expedition has been really interesting for us on all fronts. We have been able to use different equipment, survey at different depths and develop of a series of experiments, which will help to expand our current understanding on the effects of ocean acidification.

Our SPI work will also provide some very interesting ecological information for some of the study sites. The ability to study in-situ fauna and their activities across different habitat types adjacent to the cold water corals areas is a real bonus. Our SPI images have been collected as a series of ~1.5 to 2 km transects. We were able to target specific areas since we had multibeam data available to support our transect designs.

We have collected approximately 300 SPI images at the three study sites. The data will keep me busy with the data analysis over the next few months; the results are very interesting and will help us to expand our current knowledge. After an initial review of some of these images I can see there are differences across the sites. They show numerous species of fauna (e.g. sponges, polychaete tubes, squat lobsters, brittle stars and coral) and biogenic structures (e.g. burrows, feeding voids, redox layers and sediment types) in the habitats located around the *Lophelia pertusa* reefs. We hope to use this information to help understand the existing biodiversity and function (e.g. bioturbation) of the communities adjacent to the cold-water coral reefs.

The Sediment Profile Imagery (SPI) is an in-situ technique, which takes vertical profile pictures of the upper 20 cm of soft sediments. The images can provide clear insight into the relationship between fauna and their habitat. We will be able to integrate these data sets as baseline information to understand the potential effects caused by ocean acidification on these systems.

I have included some of our images, see our results.....

Posted on [Tuesday, June 12, 2012](#)

Written by Silvana Birchenough

Day 25: Bloomin' Ocean Today has been another day filled with mud - this time on the deck of the ship as the box corer brings it up to for benthic sampling. But more about that tomorrow. Today's blog is an update from Helen....

The last few days of the cruise are rolling on... Since my first blog some time ago, the sun has mostly been hidden behind a sky of grey, and we've been dodging bad weather for the last few weeks. Despite this the ship has been surprisingly stable. In fact as I am gently rocked awake in the mornings I often think the weather has improved. However as I sway and bump my way down the corridor from my room to the lab I realise I am wrong – I am not drunk, which is perhaps how it looks, I'm actually just suffering the effects of gravity on a rocking ship.

I am sat here now, very much as I was sat last time I wrote a blog: running my DIC and alkalinity machines measuring the carbon in the seawater... I hear the beep, I change the sample... I shall summarise my ship life over the last 24 days in numbers: so far I've: - analysed 343 water samples from depths of 2000 m to the surface (that's 17,150 beeps!) - made 48 CTD casts, overall bringing about 11 tonnes of water to the surface to be sampled or used in ship-board incubations - and drunk well over a million cups of tea!!

I've also discovered the in-lab computer monitors, which display information about the ship's goings-on. These monitors are wired to the ship's main computer and are displayed in all the main labs. A touch screen display shows everything from the ship's position, direction and speed, to information about how quickly the winch is going up or down, and what depth the instrument is at (this is particularly useful for me to run out to the CTD between beeps!). There is also a weather screen, and as the number of samples I have to analyse slowly goes down, I've watched the wind steadily increase (we've seen gusts over 40 mph – force 8), and this affects what instruments we can deploy.

The other important factor that determines when we can deploy instruments is the sea state. On the ship display there is also a screen, which shows the pitch, roll and heave of the ship. The pitch is the up-down (fore-aft) movement of the ship, the roll is the side-to-side movement, and the heave is the overall lift or drop of the ship with the swell. On a flat sea, the pitch, roll and heave would all be 0 degrees but as the waves increase and the ship moves around more, the values increase. So the other thing I've been watching as I sit waiting for the beep, is the increase in pitch and roll of the ship. The biggest value I've seen is a roll of about 6 degrees but we tend to be having rolls and pitches between 1 to 3 degrees (although right now its stable). So the numbers don't seem very high, but when I stand up to change my samples I feel the pull of the waves and I find myself balancing and swaying to stay vertical. To confirm all these numbers, all I have to do is take a look at the waves outside the porthole. Every few seconds I see a glimpse of grey dark waves then a few seconds later the horizon disappears and I'm looking up at the grey cloudy sky.

The other thing I've been looking at is the data from the CTD, this instrument measures Conductivity (or salinity), Temperature with Depth, and therefore provides us with a profile of how cold and salty the sea is through the water column. These parameters are really important for looking at the physical dynamics of the ocean and interpreting our data. From these profiles I can tell you where a reef is located, when there is an internal wave from a tide, or even where the gulf stream is. The last few days we've been watching the sea surface change colour, its stripy white mixed in with the blue. Much like a swirl of two ice creams being mixed together. The white is actually a coccolithophore bloom. Coccolithophores are tiny microscopic plants that make calcium carbonate plates, like armour plating. When these phytoplankton die the plates fall off and a mass of chalky whiteness fills the sea. These blooms are so extensive they can be seen from space. The swirls happen because the ocean is dynamic, there are eddies and waves that carry these microscopic plants around. It's been fantastic to match all this up: From satellite to ship-board photographs, to the water physical dynamics (the CTD), to the microscopic plants, and then to the invisible, yet ever present, dissolved inorganic carbon.

Posted on [Tuesday, June 12, 2012](#)

Written by Helen Findlay

Day 26: Mud, Glorious Mud Cries of 'land' filled the chemistry lab yesterday, as the Hebridean islands came back into sight. Following a successful box coring campaign at the Hebrides Terrace Seamount, when scientists reverted to toddlers in the presence of mud, we were back at Mingulay for a final round of ROV dives and multibeam surveys.

Previously we have heard about the exciting things happening on the sediment surface. Equally exciting are the animals living inside the sediment layer. These beasts living inside the sediment are referred to as bioturbators. They build tunnels through the sediment and by doing so they allow oxygen and food particles to penetrate the deeper layers.

The SPI camera, which was introduced by [Silvana](#), allows the visualisation of the water-sediment interface. This gives exciting snapshots of the sediment layer. [Box corers](#) are a great way to expand on that snapshot. They penetrate the sediment (on this cruise with the surface area of 2.5 square m) and collect a block of sediment. The penetration depth depends on the speed it is lowered at and the sediment consistency.

The samples that are collected are then sliced up into different layers of sediment and sieved, which generally turns into a team bonding exercise because all hands are needed on deck (Pic 2 & 3). Samples vary greatly with distance to seamounts and corals and occasionally we also find animals such as xenophyophores on the

sediment surface. For those that are unaware, xenophyophore are giant singular celled protists that can grow to up to 10 cm in diameter. With all this muddy work, the ship deck tends to need cleaning afterwards...

Posted on [Wednesday, June 13, 2012](#) Written by **Claudia Alt**

Day 27: Homeward Bound... And we're off! After a day of ROV sampling at Mingulay and a night of multibeam mapping, the 'over-the-side' science has ended, and as of 0600 we are beginning our journey back to the delights of Govan! So a final equipment blog, coming today courtesy of Juan from Heriot –Watt University.

The Mingulay Reef Complex has a unique oceanographic phenomena; a downwelling of water movement from the surface of the ocean towards the bottom every 6 hours. We need to further understand the waters surrounding the area, in order to know how the cold-water corals feed, reproduces and the possible impact of climate change in the near future.

We use several instruments to measure water column characteristics. For example, we have devices that measure the current speed (as the Doppler effect), as well as systems that continually measure temperature, salinity, chlorophyll and plankton in the ocean (the [MVP](#)), from the surface to over 500 m deep, over several kilometres as we trundle along. We can also create 3D maps, which we use to plan the sampling areas and the ROV dives. All this information will be processed in our laboratories and computers.

Life on a research vessel is full of surprises, sieving mud at night in the middle of the ocean, some time with whales close to you, watching squid at 200 meters on TV screens, marine birds above us every single day and watching the sun rise with other colleagues, seriously it is an experience of your life.....

Tomorrow we will have our final blog from the Changing Oceans Expedition, following a day of packing, steaming and that final sunset.

Posted on [Thursday, June 14, 2012](#) Written by **Juan Moreno Navas**

Day 28: They think its all over....it is now! There was a real flurry of activity on the ship yesterday as everyone dismantled their equipment and started the long process of clearing up after a month at sea. Throughout yesterday load after load of boxes and metal cages full of samples was moved up out of the ship's hold onto the deck ready to be lifted off by crane today.

When you see the piles of boxes and sample buckets you start to realise what a lot's been achieved over the last month. We have terabytes of digital video of spectacular cold-water coral reefs and thousands of still images – it is a bit daunting to think how long it will take to process and analyse, we can be sure this expedition will be keeping us all busy for some time to come! But we didn't just collect pretty pictures. The [ROV](#) worked hard gathering samples for experiments on board the ship to help us understand what implications ocean warming and acidification may have for the corals that build deep-sea coral reefs. We deployed 'Jackson' the [Eddy](#) lander system to measure oxygen consumption, and the first results look very promising. We used [CTD](#), [MVP](#) and [SAPS](#) to understand the environment the coral ecosystems need. It's this combination of taking measurements on the seafloor alongside experiments with corals on board the ship that will really help us understand how these ecosystems function.

Of course none of this would have been possible without the ship and her crew. On behalf of all the scientists on board we would like to thank the Captain, ship's crew and all the engineers and technicians who have made the Changing Oceans Expedition such a productive and enjoyable experience.

Posted on [Friday, June 15, 2012](#) Written by **Murray Roberts**

Appendix 6: JC073 RRS *James Cook* Instrument Specification

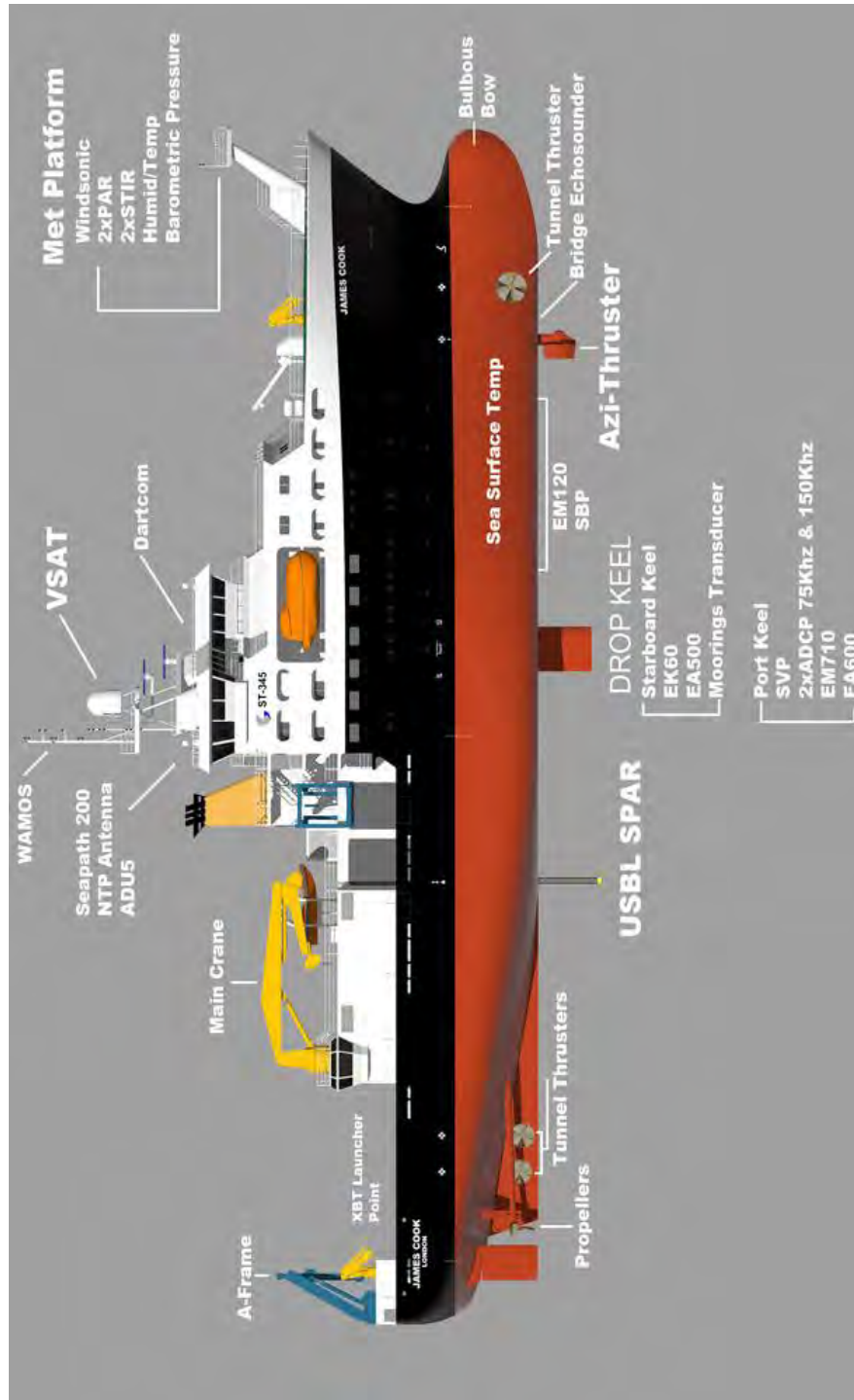

Positioning and Attitude

The outputs from each of the GPS systems are logged by the Techsas and Level-C data loggers. Their operation is monitored either from the main lab or the bridge.

Applanix POS MV 320 [Primary Science GPS and attitude sensor]

Please note that the position output is the position of the ship's common reference point (the cross on the top of the POS MV MRU in the gravity room).

Specification: Posmv_datasheet.pdf

Seapath DPS200 [Secondary Science GPS and attitude sensor]

Please note that the position output is the position of the ship's common reference point (the cross on the top of the POSMV MRU in the gravity room).

Specification: Seapath200.pdf

Ashtech ADU5 [Redundant GPS and attitude]

Please note that the position output is the position of the antenna. This GPS is not referenced to any other systems. This system does not receive Differential corrections.

Specification: ADU5_Datasheet.pdf

DPS116 [Ship's DP GPS with science output]

Please note that the position output is the position of the antenna. This GPS is not referenced to any other systems.

Specification: DPS116_Datasheet.pdf

CNAV [GPS and RTCM Satellite Corrections Receiver]

Please note that the position output is the position of the antenna. This GPS is not referenced to any other systems. It is primarily used to provide RTCM differential corrections to the other GPS systems.

Specification: CNav3050Brochure.pdf

Multibeam Sonar

Kongsberg EM120 deep water swath 1° × 1° version (191 beams)

Specification: Em120_product_description.pdf

Kongsberg EM710 shallow water swath 2° × 2° version (128 beams)

Specification: Em710_product_specification.pdf

Kongsberg SBP120 sub bottom profiler

Specification: Sbp120_product_specification_lr.pdf

Valeport Sound Velocity Probe

The multibeam systems require an accurate sound velocity profile to acquire data. This can be obtained either from lowering the sound velocity probe through the water column or from processed CTD data. The Valeports have a maximum depth of 5000 m.

ADCPs

Teledyne RDI 75 kHz Ocean Observer

Teledyne RDI 150 kHz Ocean Observer

USBL

Sonardyne Fusion USBL

A standard head is fitted to a deployment pole that extends through the vessel's hull. The Fusion, Ranger and Viewpoint software packages are available. Various beacons can be sent to the ship to provide position information, although generally only 4000 m rated Wideband and Supersub Minis are carried onboard. Currently a Ranger 1 PC and NCU is fitted but a Ranger 2 PC and an NSH is available onboard if needed. The standard head is a Mark 5 GDT that is capable of Wideband 1 operation.

Singlebeam Sonar

Kongsberg EA600

A 12 kHz EA600 is fitted to the port drop keel as the primary scientific echo sounder. The EA600 depth outputs are logged by the TECHSAS data logger. Raw data, images and hard copy laser printouts are also available.

Specification: Ea600_data_sheet_lr.pdf

Simrad EA500

A 10 kHz EA500 is fitted using a transducer on the starboard drop keel. The EA500's data is not logged and the system is primarily for moorings work requiring a 10 kHz echo sounder. The EA500's transducer is regularly used for communicating with 10 and 12 kHz moorings.

Synchronisation

Simrad Synchronisation Unit (SSU)

Metrological

NMFSS Surfmet

Data is collected by the NMFSS Surfmet program and logged by the Techsas and Level-C data logging systems.

WAMOS Wave Radar

Data is logged in WAMOS' own format. Summary wave information is available in one of the ASCII files generated.

Specification: WaMoSII_geninfo_2010.pdf

Manufacturer's website: <http://www.oceanwaves.org/>

Additional Systems

Kongsberg EK60 Fisheries multi-frequency Echosounder

The EK60 has 18, 38, 70, 120 and 200 kHz transducers fitted to the starboard drop keel. Equipment to calibrate the system is carried onboard.

Specification: Ek60_brochure_english_reduced.pdf

Olex Charting Software

Olex provides rapid visualisation of multibeam data.

Specification: Olex_engelsk.pdf

Manufacturer's website: http://www.olex.no/index_e.html

Data Logging & Management

TECHSAS Data Logger

The Techsas data logging system saves data in the self describing NetCDF format that can be easily read from the Matlab program or using the freely available NetCDF libraries.

Techsas also broadcasts the logged data across the ship's network in UDP NMEA packets. Please see the separate NetCDF documentation for details of the variables logged.

RVS Level C

The Level-C system logs the Techsas UDP packets in the Level-C binary format. It allows ASCII dumps of the data to be rapidly generated at custom intervals or averaging periods. The NMFSS Science Systems Technician will be able to generate the necessary reports from the Level-C system for you.

Data Storage and Processing

Sun Sparc Enterprise

The primary data processing server is a Sun Sparc Enterprise T5120 with 8GB RAM. Matlab R2009b with the Statistics Toolbox is installed along with the RVS Level-C package.

Dell R510 NAS

A Dell R510 Network Attached Storage server with 16 TByte of RAID protected storage is used for data storage. At the end of the cruise data is written to portable USB hard disks with copies given to the Principal Scientist and to BODC. A second R510 with 4 TBytes of RAID protected storage provides redundancy.

Appendix 7: JC073 NMFSS Ship Systems Computing Cruise Report

All times given in this report are in UT.

Technicians: James Burriss, Dave Edge, Terry Edwards, Mark Maltby (Science Systems Tech), Richie Phipps, Jon Seddon (Science Systems Tech) (j.seddon@noc.ac.uk or nmfss-shipsys@noc.soton.ac.uk), Darren Young

Meteorology monitoring package.

The Surfmet system was run throughout the cruise. Please see the separate BODC information sheet JC73_Surfmet_sensor_information_sheet.docx for details of the sensors used and the calibrations that need to be applied. The calibration sheets are included in the directory Ship_Systems\Met\SURFMET\calibrations.

Pumped sea water sampling system [hull bottom intake]. Sea surface monitoring system [salinity, temperature, transmissometer, fluorimeter].

The Surfmet system was run throughout the cruise. Please see the separate BODC information sheet for details of the sensors used and the calibrations that need to be applied.

Several boat transfers happened on 20th May. The scupper that water from the water sampling system flows into empties over the side of the ship at the starboard waist where boat transfers happen from. Crew members turned the supply to the water sampling system off during the transfers but did not turn them back on again or tell the technicians that the system had been turned off. There was therefore no flow through the water sampling system between 07:00 and 12:08 and again between 14:15 and 16:50 on 20th May. The salinity, fluorimeter and transmissometer data is therefore invalid during this period.

There were problems with air getting stuck in the system, which affected data between the times below. Air was getting stuck in the system during the long periods when sat on station with the thrusters running. There were no problems with bubbles when the vessel was on passage. The bubbles would often form an air lock and reduce the flow rate through the sensors to 0.5 l/min. This air lock can then suddenly release allowing the flow of water to resume and introducing water from the new ship's location into the instruments and causing a step in the values measured. The SBE45 thermosalinograph (TSG) was swapped from serial number 0233 to 0230 at 20:35 to check that the noise from the bubbles was caused by the bubbles and was not due to the instrument.

Start of Bubble Problems	End of Bubble Problems
20/5/12 20:42	21/5/12 08:14
21/5/12 12:10	21/5/12 13:23
24/5/12 15:20	24/5/12 17:17
27/5/12 unknown time (gradual build up)	27/5/12 08:02
30/5/12 21:57	1/6/12 00:03
1/6/12 gradual build up	1/6/12 08:11
6/6/12 gradual build up	6/6/12 19:51
10/6/12 gradual build up	10/6/12 08:10
12/6/12 gradual build up	12/6/12 14:09

On several occasions during the times given in the table below noise was seen in the anemometer data. The direction would jump from 0° to 359° on alternate samples and the speed would jump from 0 to 50 ms⁻¹ on alternate samples. This generally happened when the vessel was sat head to wind and the anemometer direction was close to either 0° or 359°. This noise has been seen on previous cruises and was assumed to be due to the anemometer having problems switching its direction output quickly enough across its full output range. The anemometer's manufacturers were consulted and they said that this is an indication of an error state that is caused by either dirt on the transducers, a transducer failure or radio frequency interference. Therefore the anemometer was cleaned with mild detergent

between 14:00 and 15:00 on June 7th. No dirt was visible on the transducers. The problem has not reoccurred since then.

Start of Anemometer Noise	End of Anemometer Noise
5/6/12 19:00	5/6/12 22:30
6/6/12 04:55	6/6/12 05:30
6/6/12 13:00	6/6/12 15:00
6/6/12 18:00	6/6/12 19:05

Ship scientific computing systems.

Data was logged by the Techsas data acquisition system into NetCDF files. The format of the NetCDF files is given in the file NMFSS_NetCDF_Description_Cook.docx. The instruments logged are given in JC73_Ship_fitted_information_sheet_JC.docx. Data was additionally logged into the RVS Level-C format, which is described in the same document. An ASCII dump of each of the Level-C streams was included on the final data disk.

A Public network drive was created to allow scientists to store and share their own data, reports and photographs. A copy has been included on the data disk.

GPS.

The POSMV GPS' secondary GPS antenna failed prior to the start of the cruise and it was not possible to access the top of the mast to replace it. The POSMV's positions were not affected by this failure but the second antenna is used to compensate for drift in the yaw component of the POSMV's gyro. In port the POSMV's heading was therefore out by up to 5°, but at sea the error was never more than around 1°. Comparing the POSMV's heading against the heading from the Seapath 200 and the ship's gyro showed that the error was varying in magnitude. It would therefore not be possible to correct data that used the heading output from the POSMV. Therefore the multi beam systems were swapped to obtain their position and attitude data from the Seapath 200 while running surveys.

The Seapath 200 generates positions at the ship's common reference point. Therefore positions from the Seapath 200 should be identical to those from the POSMV. The Seapath 200 performed well throughout the cruise.

The ADU5 crashed and did not output any attitude data on 28th May from 01:51 until it was power cycled at 08:21.

Drop Keels.

To give the best performance from the EM710 the port drop keel was lowered by 2.708 m at 01:06 and returned flush at 06:45 on 20th May. The z component of the EM710 transducers' position was changed to compensate for the change in keel location but the ADCP and EA600's transducers were not changed and so were out by 2.708 m during this time. The port drop keel was again lowered between 06:45 on June 7th and 13:15 on June 8th by 2.705 m. The sensor location was updated in the EM710 but not in the ADCPs or EA600. The drop keel was lowered for the final hallow water multi-beam survey between 19:10 on 12th June and 06:15 on 13th June; it was lowered by 2.708 m and its location was updated in the EM710 but not in the ADCPs or the EA600.

Kongsberg EA600 12 kHz single beam echo sounder.

The EA600 single beam echo sounder was run throughout the cruise. The EA600 was used with a constant sound velocity of 1500 ms⁻¹ throughout the water column to allow it to be corrected for sound velocity in post processing. As well as depths being logged to the Techsas and Level-C data loggers, files were saved as .BMP images and in raw Kongsberg format. Its location on the vessel was not updated when the drop keels were lowered because the value could not be found in the software. For future reference the transducer location can be updated though the Transceiver Settings menu accessed by clicking on the 12 kHz text in the top left corner of the screen.

Kongsberg EM120 and EM710 Multi beam echo sounders.

A swath survey was attempted early on 20th May near the Mingulay Reef. The plan had been to use the EM710 due to the water depth. At the start of the survey the swath width from the EM710 was narrower than expected at around twice the water depth. It was noticed that the EM710 had only 128 beams. It was thought that the EM710 should have more than this and a quick check of the training notes said that it should have 200 beams. It was believed that the EM710's Processing Unit (PU) has lost communication with some of the electronics and so the PU and PC were rebooted. After which the system still had only 128 beams. A BIST failed on the receiver noise check, but passed when the 75 kHz ADCP system was stopped. It was therefore decided to run the survey with the EM120 instead. The GPS systems were therefore quickly reconfigured so that the EM120 and EM710 were both fed from the Seapath 200, including the PPS signal.

After the survey further investigations into the EM710's poor performance revealed that the James Cook is fitted with a 2° × 2° EM710, which has only 128 beams. The SVP that had been loaded into both multi beam systems had been thinned too severely. When the SVP was loaded without any thinning (the water depth in the area was only 210m) the EM710 increased its swath width to around four times the water depth.

During the next survey on June 7th it was found that the EM710 has a marine mammal protection mode. This is accessed from Runtime Parameters->Filters and Gains->Mammal Protection. The options were set for a power level of -20 dB and a delay of 0 minutes, which left the transmit power attenuated permanently by 20 dB. The power level was then changed to maximum and there was no attenuation. The depth data and back scatter were much improved when this was changed. There is no similar option on the EM120.

Sound Velocity Profiles.

The sound velocity profiles listed in the table below were used in the EM120, EM710 and USBL systems. They are included on the data disk. The profiles were taken with a Valeport Midas serial number 22241, or with the vessel's CTD.

Installation Time	Profile	Location
Start of cruise	Cast-001-JC062-SORTED_thinned.asvp	48° 57.53'N 16° 30.69'W
19/5/12 16:22	USBL only 20120519_SV001_cleaned.pro	56° 49.59' N 7° 23.41' W
20/5/12 01:38	EM120 and EM710 only 20120520_JC073_004_thinned.asvp	57° 00.24' N 7° 13.28' W
20/5/12 13:00	USBL 20120520_JC073_004_thinned.pro	57° 00.24' N 7° 13.28' W
20/5/12 17:00	EM710 20120520_JC073_004_cleaned.asvp	57° 00.24' N 7° 13.28' W
26/5/12 03:53	20120526_extended_thinned.(asvp/pro)	55° 33.40' N 15° 39.11' W
28/5/12 09:45	20120528_JC073_Stn069_thinned.(asvp/pro)	55° 33.66' N 15° 39.32' W
31/5/12 12:39	31052012_sorted_thinned.asvp EM120 31052012_sorted.pro USBL	55° 33.19' N 15° 39.19'W
6/6/12 13:00	USBL CTD_Derived\JC73_CTD_45\JC073_CTD045.pro	55° 29.15' N 15° 48.03' W
7/6/12 07:22	20120607_Stn143_thinned.(asvp/pro)	57° 21.48' N 14° 43.07' W
9/6/12 13:40	CTD_Derived\JC73_CTD_48_thinned.(asvp/pro)	56° 34.83' N 10° 18.75 W
12/6/12 12:08	20120612_sorted.(asvp/pro)	56° 49.05' N 007° 23.41 W

Kongsberg SBP120 sub bottom profiler (3°).

The SBP120 was run on several occasions. Data was saved in SEG-Y format. The display settings that gave the best results are:

Gain correction

Transmission loss: 0 dB/m

Filters

Filter type: Matched
Corner frequencies: Auto
Replica shaping: enabled

Attribute processing

Attributes: Inst. amplitude

Automatic gain control

Window length: 10%
Apply point: 0%
Amp. Scaling: 20%

75 kHz and 150 kHz hull mounted ADCP system.

Both ADCP systems were run without problems throughout the cruise. The scientific party set-up the configurations, which are included on the data disk. The ADCP transducers' positions were not updated when the drop keels were lowered.

USBL.

During the cruise WMT beacons from the Irish Marine Institute and NMFSS Deep Platform Compact beacons were used. The Ranger 1 software was used with an NCU and a Mark 5 GDT.

The WMTs are capable of Wideband 6 operation but the vessel's transceiver is a 5G GDT which is not capable of 6G operation. Sonardyne advised the Marine Institute that they should have their address limited to within the Wideband 1 spectrum (0101 - 1514) using Wideband Test Terminal. They were set to be permanently on AT14 because the wake-up command protocol was different between Wideband 1 and 2.

During ROV dive 8 at station 040 from 22:22 – 22:29 the USBL software lost all ship position data. Bridge and ROV were informed to hold station while this was investigated. Software showed no data input from ports NCU Port 6A (\$HDT), NCU Port 6B (TSS1) and NCU Port 7B (\$GGA). All other systems were receiving ship position data. The USBL software was closed and reopened and ship position data was restored. Dive continued without further issues.

There was one beacon on the ROV's Tether Management System (TMS) and two beacons on the ROV, although normally only one was tracked as a time. The USBL beacons were configured in Ranger so that only the position of the beacon on the ROV was included in the output reports. There is no data field identifying the beacon in the GGA reports that were sent to the Techsas data logger and the OFOP software used by the scientists. Therefore if more than one beacon is included in the report there is no way of identifying which position comes from which beacon. Because only one beacon was included in the report all beacon position data logged by the Techsas and Level-C USBL modules, and OFOP, during ROV dives is the position of the beacon on the ROV.

The vessel's Wideband Sub Mini beacon was fitted to the CEFAS SPI camera for the later SPI camera operations. The USBL data recorded by the Techsas and Level-C modules during SPI camera operations was the position of the SPI camera frame.

Other Systems.

A beam zero and beam gain check were performed on 17th May. There was some confusion as the method described in the manual carried onboard did not appear to work. Nigel Brady from Micro-g Lacoste advised that the beam slew motor had been removed from S40 during its upgrade. Nigel advised that an alternative method was to turn off spring tension tracking and then move the beam up by 1000 counts. After around 15 minutes the beam will have reached its top position and the beam gain value can then be adjusted to give a full beam range deflection of 5 V. The beam zero value of 6.62 was unchanged. The beam gain was -12.71 before the calibration. The galvanometer reading with the

beam in its top position was 0.515 V. The beam gain was therefore changed to 18.69 to give a galvanometer reading of 5.000 V. The beam was then moved down by 2000 counts and was then found to have stabilised at a galvanometer reading of -5.715 V with the new beam gain. The new beam gain was saved and spring tension tracking was re-enabled.

CTD.

The CTD data is included on the data disk in Specific_Equipment\CTD\. Please see the reports in that directory for further details.

Other Data.

The ROV multibeam and CTD data was archived to the cruise data structure. The scientific party handled the rest of their data themselves. The data was all included in the Public data store and so the scientific cruise report should be consulted for details of this data.

Appendix 8: BODC Ship-fitted Systems Information Sheet

The following table lists the logging status of ship-fitted instrumentation and suites.

Manufacturer	Model	Function/data types	Logged?	Comments
Steatite	MM3S	GPS network time server (NTP)	N	Not logged but feeds times to other systems
Applanix	POS MV 320	DGPS and attitude	Y	Primary GPS
Ashtech	ADU-5	DGPS and attitude	Y	Redundant
C-Nav	3050	DGPS and DGNSS	Y	Mainly to provide differential corrections to other GPS'.
Kongsberg Seatex	DPS116	Ship's DGPS	Y	Bridge GPS
Kongsberg Seatex	Seapath 200	DGPS and attitude	Y	Secondary GPS
Sonardyne	Fusion USBL	USBL	Y	
Sperry Marine		Ship gyrocompasses x 2	Y	
Chernikeeff Instruments	Aquaprobe Mk5	Electromagnetic speed log	Y	Out of calibration
Kongsberg Maritime	Simrad EA600	Single beam echo sounder (hull)	Y	
Kongsberg Maritime	Simrad EA500	Single beam echo sounder (hull)	N	For moorings work
Kongsberg Maritime	Simrad EM120	Multibeam echo sounder (deep)	Y	
Kongsberg Maritime	Simrad EM710	Multibeam echo sounder (shallow)	Y	
Kongsberg Maritime	Simrad SBP120	Sub bottom profiler	Y	
Kongsberg Maritime	Simrad EK60	Scientific echo sounder (fisheries)	N	Not used this cruise
		CLAM system winch log	Y	
NMFSS	Surfmet	Meteorology suite	Y	
NMFSS	Surfmet	Surface hydrography suite	Y	
		Skipper log (ship's velocity)	Y	
OceanWaveS GmbH	WaMoS II	Wave Radar	N	Awaiting repair
Teledyne RD Instruments	Ocean Observer 75 kHz	VM-ADCP	Y	
Teledyne RD Instruments	Ocean Observer 150 kHz	VM-ADCP	Y	

Bestnav hierarchal ordering:

The following table lists the order of navigational systems in the *bestnav* process for positional fix.

Rank	Order of positional fixes	Comment
1	POS MV	
2	CNAV	
3	DPS116	

Relmov source:

The following table lists the navigational systems that are used in the *relmov* process for ship's motion.

Navigational source of ship's motion	Comment
POSMV Gyro	
Chernikeeff EM log	

RVS data processing:

The following table lists the RVS Level-C processing programs that were run.

Program	Was it run?	Comments
<i>bestnav</i>	Y	
<i>prodep**</i>	N	Echosounder (EA600) corrected using <i>prodep</i> 's Carter Table corrections
<i>protsg</i>	N	
<i>relmov</i>	Y	
<i>satnav</i>	N	
<i>windcalc</i>	Y	

**Please state if sound velocity probes used for depth correction instead of *prodep*.

Appendix 9: Surfmet Sensor Information

Meteorology platform (Foremast)

JAMES COOK MET PLATFORM

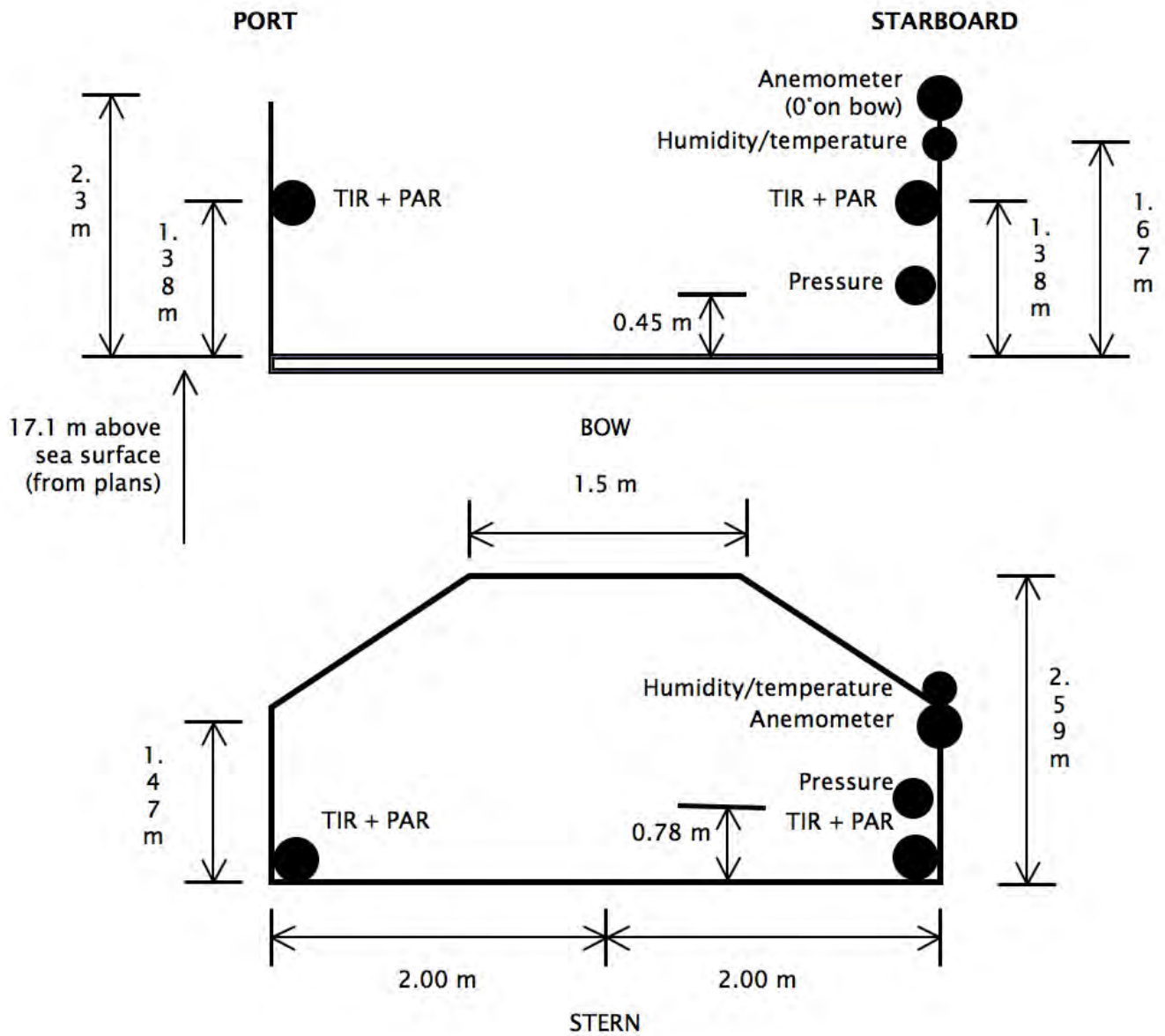

Pumped seawater flow rates (ml/min):	1500
Anemometer orientation on bow (deg):	0
Seawater intake depth (m):	5.5

Fitted Sensors:

Manufacturer	Sensor	Serial No.	Comments (eg. port)	Calibration applied?	Last calibration date
Skye	PAR	38884	Port	No	25/11/2010
Skye	PAR	28560	Starboard	No	5/7/2011
Kipp & Zonen	TIR	973134	Starboard	No	15/7/2011
Kipp & Zonen	TIR	994133	Port	No	9/8/2010
Vaisala	HMP45A	C1320001		No	5/7/2011
Gill	Windsonic	064537		No	No cal
Vaisala	PTB100	U1420016		No	26/3/2012
Wet Labs	WS3S Fluorimeter	WS3S-246		No	9/8/2011
Wet Labs	CST Transmissometer	CST-1132PR		No	25/7/2011
Sea-Bird	SBE38 Temperature	3853440-0416		No	27/06/2011
Sea-Bird	SBE45 TSG	4548881-0233	Until 27/5/12 20:35	No	19/7/2011
		4548881-0230	From 27/5/12 20:35	No	6/9/2011

Spare Sensors:

Manufacturer	Sensor	Serial No.	Comments (eg. port)	Calibration applied?	Last calibration date
Sea-Bird	SBE45 TSG	4548881-0230		No	9/6/2011
Wet Labs	CST Transmissometer	CST-114PR		No	20/10/2010
Wet Labs	WS3S Fluorimeter	WS3S-351P		No	9/8/2011
Kipp & Zonen	TIR	973135		No	15/7/2011
Vaisala	HMP45	E1055002		No	21/10/2011
Vaisala	PTB100	R0450005		No	17/5/2011
Skye	PAR	28561		No	11/7/2011
Gill	Windsonic	064538			
Sea-Bird	SBE38 Temperature	3854115-490		No	4/11/2011

Appendix 10: National Marine Facilities – RRS *James Cook* NetCDF Description. Version 1.14 (June 2012)

This appendix describes how the variables logged by the National Marine Facilities Sea System's Techsas data logging system are recorded and processed on RRS *James Cook*. There is a similar set-up on RRS *Discovery*, but the NetCDF filenames are different; a similar summary will be produced for RRS *Discovery*. If you have any questions then please contact the Scientific Ship Systems Group via email at: nmfss-shipsys@noc.soton.ac.uk or via the head of the group, Gareth Knight on 023 8059 6281.

The following list of variables is arranged by the NetCDF files in which each variable occurs, with the RVS Level-C stream name afterwards in round brackets. The name in round brackets is the variable name from the RVS Level-C data file. The units are given in square brackets. The filenames are arranged alphabetically, with all uppercase letters coming before lowercase letters.

The **time** variable in the NetCDF files is the number of days since 30th December 1899 00:00:00 UTC. The **Time** variable in the RVS Level-C files when they are presented in an ASCII format varies depending upon the program used to generate the ASCII file, but is commonly YY DDD HH:MM:SS where YY is the last two digits of the year, DDD is the Julian day of the year and the remainder is the UTC time.

Variables in the Level-C files have a status flag associated with them. The value of these status flags indicates the following:

Flag	Meaning
60	Accept
55	Correct
50	Good (default)
45	Uncorrected
40	Interpolated
35	Restart
30	Suspect
20	Reject
10	Test
0	Not written

Changes

Version 1.10: an error was found in YYYYMMDD-hhmmss-MET-JC-SM_JC1.SURFMETv2 (surfmet). In version 1.00 the anemometer was described as having an RS232 output, when in fact it had an analogue output. This has been corrected in this version. The error was solely in this document; no changes have been made to the hardware.

Version 1.11: added the post-processed Level-C data streams relmov, bestnav, bestdrf, pro_wind and prodep. Added the RVS Level-C statuses and a complete description of the USBL data for the first time.

Version 1.12: a bug was discovered in the CNAV NetCDF data. All NetCDF data logged since the GPS was fitted to the vessel on cruise JC052 in September 2010 was logged in the format described in version 1.12 of this document.

Version 1.13: added in details about the CLAM cable types and a bug that occurred in the CLAM cable type prior to cruise JC68.

Version 1.14: improved the description of the USBL accuracy.

YYYYMMDD-hhmmss-AirSeal-S84_JC1.AirSeal (gravity)

This file contains data from the Micro-g Lacoste gravity meter.

grav_av (grav_av) [counter units] is the filtered gravity value.

springt (springt) [counter units] is the spring tension.

beam (beam) [volt × 750000] is the beam position.

vc (vc) [see manual] VCC data field.

al (al) [see manual] AL data field.

ax (ax) [see manual] AX data field.

ve (ve) [see manual] VE data field.

ax2 (ax2) [see manual] AX2 data field.

xac2 (xac2) [see manual] XACC2 data field.

lac2 (lac2) [see manual] LACC2 data field.

xac (xac) [Gal] Cross acceleration.

lac (lac) [Gal] Longitudinal acceleration.

eotcor (eotcor) [milliGal] EOTVOS correction.

lat (lat) [degree] is the latitude that the gravity value was taken at.

lon (lon) [degree] is the longitude that the gravity value was taken at.

heading (heading) [degree] is the course made good from the GPS data.

velocity (vel) [knot] is the vessel's velocity from the GPS data.

time (Time) []

YYYYMMDD-hhmmss-CLAM-CLAM_JC1.CLAM (winch)

The CLAM system records data from the ship's permanently fitted winches.

cabltype (cabltype) [] is the type of cable in operation.

The cable types are shown below. A bug in the CLAM software was fixed on 16th January 2012. The cable types prior to and after this date are shown.

Numeric Value	Cable Type Prior to 16/01/2012	Cable Type After 16/01/2012
0	No winch selected or Deep Tow	No winch selected
1	CTD1	CTD1
2		CTD2
3	CTD2 or Core Warp	Core Warp
4	Trawl	Trawl
5		Fibre Optic Deep Tow

6	Plasma	Plasma
---	--------	--------

cablout (cablout) [metre] is the length of cable deployed.

rate (rate) [metre per minute] is the rate of cable deployment. A positive rate indicates that the cable is being paid out (veered) and a negative rate indicates that the cable is being hauled in.

tension (tension) [tonne] is the cable tension.

btension (btension) [tonne] is the cable back tension.

angle (angle) [degree] is the wire angle which may no longer be measured.

time (Time) []

YYYYMMDD-hhmmss-EA600-EA600_JC1.EA600 (ea600m)

The EA600 echo sounder outputs the depth that it measures from the sea bed to the ship's waterline, (i.e. compensating for the depth of the sensor below the waterline). The compensation factor is set in the software. The sensor is mounted on the drop keel. The sonar user should modify the compensation factor when the drop keel is moved. The depth is output in various units, all of which are logged to the NetCDF file. Only the depth in metres is recorded in the RVS data files. No compensation is made for the current tidal height. No information about the sound velocity correction applied is contained in the file and the cruise report should be consulted for further information.

depthft (not logged) [feet]

depthm (depth) [metre]

depthF (not logged) [fathom]

time (Time) []

YYYYMMDD-hhmmss-EMLog-log_chf_JC1.EMLog (log_chf)

The Chernikeef Electromagnetic Log measures the ship's velocity through the water.

speedfa (speedfa) [knot] is the speed of the vessel through the water in a fore and aft direction. Forward motion results in a positive speed.

speedps (speedps) [knot] is the speed of the vessel through the water sideways. Starboard motion results in a positive speed.

time (Time) []

YYYYMMDD-hhmmss-GPPAT-GPPAT_JC1.GPPAT (adu5pat)

This data file contains data from the Ashtech ADU5 GPS based attitude measuring system.

sec (measureT) [days] is the time stamp applied to the data by the GPS unit.

lat (lat) [degree] is the latitude.

long (lon) [degree] is the longitude.

alt (alt) [metre] is the measured altitude.

hdg (heading) [degree] is the true heading of the ship.

pitch (pitch) [degree] is the pitch of the ship. A bow up rotation gives a positive pitch value.

roll (roll) [degree] is the roll of the ship. A rotation of the ship's superstructure to starboard gives a positive roll value.

mrms (mrms) [metre] attitude phase measurement RMS error.

brms (brms) [metre] attitude baseline length RMS error.

attf (not logged) [] attitude flag. 0 indicates a good attitude and 1 indicates a rough estimate or bad attitude.

time (Time) []

YYYYMMDD-hhmmss-Light-JC-SM_JC1.SURFMETv2 (surfmet)

pres (press) [hectopascal] is the atmospheric pressure. The voltage measured by the Nudam ADC is converted to hPa in the Surfmet program by the equation:

$$pres = 800 + (52 \times voltage)$$

where *voltage* is the measured voltage in volts. It is then necessary to apply the calibration factors given on the instrument's data sheet.

ppar (ppar) [volt × 10⁻⁵] is the voltage measured by the Nudam ADC in millivolts multiplied in the Surfmet software by 100, from the Photosynthetically Active Radiation (PAR) sensor on the port side of the ship's meteorological platform. To convert this value to a light intensity, it should be divided by the calibration factor specified on each sensor's data sheet, paying attention to the fact that the calibration factor typically has units of microvolt per watt per metre squared and this value has units of ×10⁻⁵ volts.

spar (spar) [volt × 10⁻⁵] is the voltage measured by the Nudam ADC in millivolts multiplied in the Surfmet software by 100, from the PAR sensor on the starboard side of the ship's meteorological platform. To convert this value to a light intensity, it should be divided by the calibration factor specified on each sensor's data sheet.

ptir (ptir) [volt × 10⁻⁵] is the voltage measured by the Nudam ADC in millivolts multiplied in the Surfmet software by 100, from the Total Irradiance (TIR) sensor on the port side of the ship's meteorological platform. To convert this value to a light intensity, it should be divided by the calibration factor specified on each sensor's data sheet.

stir (stir) [volt × 10⁻⁵] is the voltage measured by the Nudam ADC in millivolts multiplied in the Surfmet software by 100, from the TIR sensor on the starboard side of the ship's meteorological platform. To convert this value to a light intensity, it should be divided by the calibration factor specified on each sensor's data sheet.

time (Time) []

YYYYMMDD-hhmmss-MET-JC-SM_JC1.SURFMETv2 (surfmet)

speed (speed) [metre per second] is the relative wind velocity. The wind speed and direction are at the height of the anemometer on the met platform, approximately 18.7 metres above the sea surface depending upon the trim of the ship. The sensor outputs a voltage between 0 and 5 volts corresponding to 0 and 50 ms⁻¹. These voltages are measured by a Nudam ADC. The Surfmet software converts this voltage to a speed using the equation:

$$speed = (50/5) \times voltage$$

direct (direct) [degree] is the relative wind direction with 0° being at the bow. The sensor outputs a voltage between 0 and 5 volts corresponding to 0 and 360°. The Surfmet software converts this voltage to a direction using the equation:

$$direct = (360/5) \times voltage$$

airtemp (airtemp) [degree Celsius] is the air temperature. The sensor outputs a voltage between 0 and 1 volt, corresponding to -40°C to +60°C. This voltage is measured by a Nudam ADC and is converted to a temperature in the Surfmet software using the equation:

$$airtemp = (100 \times voltage) - 40$$

where *voltage* is the measured voltage in volts.

humid (humidity) [percent] is the relative humidity of the air. The sensor outputs a voltage between 0 and 1 volt, corresponding to 0% and 100% relative humidity respectively. The voltage is measured by a Nudam ADC and is converted to relative humidity in the Surfmet software using the equation:

$$humid = 100 \times voltage$$

where *voltage* is the measured voltage in volts.

time (Time) []

YYYYMMDD-hhmmss-PASHRPOS-ADUPOS_JC1.PASHR (adu5pos)

This data file contains data from the Ashtech ADU5 GPS based attitude measuring system.

type (type) [] specifies the position type. 0 indicates a raw position and 2 specifies a differentially corrected position.

svc (svc) [] is number of satellites used to compute the position.

sec (measureT) [] is the time stamp applied to the data by the ADU5 GPS.

lat (lat) [degree] is the latitude.

long (lon) [degree] is the longitude.

alt (alt) [metre] is the altitude.

cmg (cmg) [degree true] is the course made good, or course over the ground.

smg (smg) [knot] is the speed over the ground, or speed made good.

vvel (vvel) [metre per second] is the vertical velocity with a positive value indicating motion upwards.

pdop (pdop) [] is the GPS positional dilution of precision.

hdop (hdop) [] is the GPS horizontal dilution of precision.

vdop (vdop) [] is the GPS vertical dilution of precision.

tdop (tdop) [] is the GPS time dilution of precision.

time (Time) []

YYYYMMDD-hhmmss-SBE45-SBE45_JC1.TSG (sbe45)

The Sea-Bird Electronics SBE45 Thermosalinograph's (TSG) data is logged directly by the Techsas data acquisition system. Techsas rebroadcasts the data and it is logged for a second time in the Surfmet data files.

temp_h (temp_h) [degree Celsius] is the water temperature measured in the SBE45 housing. The SBE45 contains its own calibration coefficients and outputs over RS232 the calibrated temperature.

cond (cond) [siemen per metre] is the conductivity measured by the SBE45. It is the calibrated conductivity output via RS232.

salin (salin) [] is the water salinity calculated by SBE45. It is measured using the Practical Salinity Scale and hence is unit less.

sndspeer (sndspeed) [metre per second] is the velocity of sound in the sampled water calculated by the SBE45 using the Chen-Millero equation.

temp_r (temp_r) [degree Celsius] is the water temperature measured by the SBE38 remote thermometer at the raw water inlet to the ship. The SBE38 contains its own calibration coefficients and outputs over RS232 the calibrated temperature.

time (Time) []

YYYYMMDD-hhmmss-Surf-JC-SM_JC1.SURFMETv2 (surfmet)

temp_h (temp_h) [degree Celsius] is the SBE45 housing water temperature.

temp_m (temp_r) [degree Celsius] is the SBE38 remote temperature at the ship's raw water inlet.

cond (cond) [siemen per metre] is the conductivity measured by the SBE45.

fluo (fluo) [volt] is the voltage measured by the Nudam Analogue to Digital Converter (ADC) from the Wet Labs WS3S Fluorimeter. Each fluorimeter's data sheet should be consulted for the equation and calibration factors to convert from voltage to chlorophyll concentration.

trans (trans) [volt] is the raw voltage measured by the Nudam ADC from the Wet Labs C-Star Transmissometer. Each transmissometer's data sheet should be consulted for the equation and calibration factors to convert from voltage to transmittance.

time (Time) []

YYYYMMDD-hhmmss-VDVHW-log_skip_JC1.Log (log_skip)

The skipper log measures the ship's speed through the water. It is primarily intended for bridge navigation purposes but is also logged by Techsas and Level-C.

heading (heading) [degree true] is the true heading of the ship. This field may not contain any data.

headMag (headMag) [degree magnetic] is the magnetic heading of the ship. This field may not contain any data.

speed (speed) [knot] is the speed of the vessel through the water.

speedKPH (speedKPH) [kilometre per hour] is the speed of the vessel through the water.

time (Time) []

YYYYMMDD-hhmmss-cnav-CNAV.GPS (gps_cnav)

This data file contains data from the CNAV GPS unit. Please note that the latitude and longitude in the NetCDF file are in a different format to other GPS'. The format used is: DDD.MMmmmmmm where the digits DDD or DD before the decimal point are the degrees, the first two digits after the decimal point are the minutes and the remaining digits are the decimal part of the minute. Therefore a latitude or longitude in the NetCDF file of 12.34567890 actually represents 12° 34.567890'. In the Level-C file latitude and longitudes are given in the usual format of decimal degrees.

measureTS (measureT) [] is the time stamp applied to the data by the GPS unit.

lat (lat) [degree] is the latitude of the CNAV GPS antenna in the format described above.

long (lon) [degree] is the longitude of the CNAV GPS antenna in the format described above.

alt (not logged) [metre] is the height of the CNAV GPS antenna above the reference ellipsoid.

prec (not logged) [] is the horizontal position precision code. It is defined by the following table:

prec	HDOP
0	HDOP < 0.3
1	0.3≤HDOP<1.0
2	1.0≤HDOP<3.0
3	3.0≤HDOP<10.0
4	10.0≤HDOP<30.0
5	30.0≤HDOP<100
6	100≤HDOP<300
7	300≤HDOP<1000
8	1000≤HDOP<3000
9	3000≤HDOP

mode (prec) [] is the mode that the GPS was operating in. 0 indicates an invalid fix, 1 a GPS fix and 2 a DGPS fix.

not logged (pdop) [] this is a null value that is only logged in the RVS data file.

gndcourse (cmg) [degree true] is the course made good, or course over the ground.

gndspeed (smg) [knot] is the speed over the ground, or speed made good.

time (Time) []

YYYYMMDD-hhmmss-gyro-GYRO1_JC1.gyr (gyropmv)

heading (heading) [degree true] is the true heading of the ship in degrees from the POSMV gyro.

time (Time) []

YYYYMMDD-hhmmss-gyro-SGYRO_JC1.gyr (gyro_s)

heading (heading) [degree true] is the true heading of the ship in degrees from the ship's gyro compass.

time (Time) []

YYYYMMDD-hhmmss-position-Applanix_GPS_JC1.gps (posmvpos)

This data file contains data from the POSMV GPS unit.

measureTS (measureT) [] is the time stamp applied to the data by the GPS unit.

lat (lat) [degree] is the latitude of the surveyed reference point (the cross on the top of the POSMV MRU).

long (lon) [degree] is the longitude of the surveyed reference point.

alt (alt) [metre] is the height of the surveyed reference point above the reference ellipsoid.

prec (prec) [] is the horizontal position precision code. It is defined by the following table:

prec	HDOP
0	HDOP < 0.3
1	0.3 ≤ HDOP < 1.0
2	1.0 ≤ HDOP < 3.0
3	3.0 ≤ HDOP < 10.0
4	10.0 ≤ HDOP < 30.0
5	30.0 ≤ HDOP < 100
6	100 ≤ HDOP < 300
7	300 ≤ HDOP < 1000
8	1000 ≤ HDOP < 3000
9	3000 ≤ HDOP

mode (mode) [] is the mode that the GPS was operating in. 0 indicates an invalid fix, 1 a GPS fix and 2 a DGPS fix.

gndcourse (cmg) [degree true] is the course made good, or course over the ground.

gndspeed (smg) [knot] is the speed over the ground, or speed made good.

time (Time) []

YYYYMMDD-hhmmss-position-DPS-116_JC1.gps (dps116)

This data file contains data from the DPS116 GPS unit.

measureTS (measureT) [] is the time stamp applied to the data by the GPS unit.

lat (lat) [degree] is the latitude of the DPS116 antenna.

long (lon) [degree] is the longitude of the DPS116 antenna.

alt (alt) [metre] is the height of the DPS116 antenna above the reference ellipsoid.

prec (prec) [] is the horizontal position precision code. It is defined by the following table:

prec	HDOP
0	HDOP < 0.3
1	$0.3 \leq \text{HDOP} < 1.0$
2	$1.0 \leq \text{HDOP} < 3.0$
3	$3.0 \leq \text{HDOP} < 10.0$
4	$10.0 \leq \text{HDOP} < 30.0$
5	$30.0 \leq \text{HDOP} < 100$
6	$100 \leq \text{HDOP} < 300$
7	$300 \leq \text{HDOP} < 1000$
8	$1000 \leq \text{HDOP} < 3000$
9	$3000 \leq \text{HDOP}$

mode (mode) [] is the mode that the GPS was operating in. 0 indicates an invalid fix, 1 a GPS fix and 2 a DGPS fix.

gndcourse (cmg) [degree true] is the course made good, or course over the ground.

gndspeed (smg) [knot] is the speed over the ground, or speed made good.

time (Time) []

YYYYMMDD-hhmmss-position-Seapath200_JC1.gps (sb-pos)

This data file contains data from the Seapath 200 GPS unit.

measureTS (not logged) [] is the time stamp applied to the data by the GPS unit.

lat (lat) [degree] is the latitude of the surveyed reference point (the cross on the top of the POSMV MRU).

long (lon) [degree] is the longitude of the surveyed reference point.

alt (not logged) [metre] is the height of the surveyed reference point above the reference ellipsoid.

prec (not logged) [] is the horizontal position precision code. It is defined by the following table:

prec	HDOP
0	HDOP < 0.3
1	0.3≤HDOP<1.0
2	1.0≤HDOP<3.0
3	3.0≤HDOP<10.0
4	10.0≤HDOP<30.0
5	30.0≤HDOP<100
6	100≤HDOP<300
7	300≤HDOP<1000
8	1000≤HDOP<3000
9	3000≤HDOP

mode (not logged) [] is the mode that the GPS was operating in. 0 indicates an invalid fix, 1 a GPS fix and 2 a DGPS fix.

gndcourse (not logged) [degree true] is the course made good, or course over the ground.

gndspeed (not logged) [knot] is the speed over the ground, or speed made good.

time (Time) []

YYYYMMDD-hhmmss-position-usbl_JC1.gps (usblpos)

This data file contains the positions of beacons being tracked by the Fusion USBL system. It is generated from the NMEA GGA stream output by the Sonardyne USBL position and uses a GPS data logging module to record the data and so there are additional fields logged that do not contain any meaningful data. The name of the beacon being tracked is not logged and so if multiple beacons are being tracked the data from all of the beacons will be logged with no way of telling which beacon the position logged refers to.

measureTS (measureT) [] is the time stamp applied to the data by the GPS unit.

lat (lat) [degree] is the latitude of the object being tracked.

long (lon) [degree] is the longitude of the object being tracked.

alt (alt) [metre] is the depth below the water surface of the object being tracked.

prec (prec) [] contains no meaningful data.

mode (mode) [] contains no meaningful data and is always 2.

gndcourse (cmg) [degree true] contains no meaningful data.

gndspped (smg) [knot] contains no meaningful data.

time (Time) []

YYYYMMDD-hhmmss-satelliteinfo-Applanix_GPS_JC1.gps (not logged)

Additional information from the Applanix POSMV regarding the GPS position fix quality.

nbseen (not logged) [] is the number of satellites that can theoretically be seen from the current position.

nbused (not logged) [] is the number of satellites actually used to compute the position.

HDOP (not logged) [] is the GPS horizontal dilution of precision.

VDOP (not logged) [] is the GPS positional dilution of precision.

PDOP (not logged) [] is the GPS vertical dilution of precision.

time (not logged) []

YYYYMMDD-hhmmss-satelliteinfo-DPS-116_JC1.gps (not logged by Level-C)

Additional information from the DPS116 regarding the GPS position fix quality.

nbseen (not logged) [] is the number of satellites that can theoretically be seen from the current position.

nbused (not logged) [] is the number of satellites actually used to compute the position.

HDOP (not logged) [] is the GPS horizontal dilution of precision.

VDOP (not logged) [] is the GPS positional dilution of precision.

PDOP (not logged) [] is the GPS vertical dilution of precision.

time (not logged) []

YYYYMMDD-hhmmss-satelliteinfo-Seapath200_JC1.gps (not logged by Level-C)

Additional information from the Seapath 200 regarding the GPS position fix quality.

nbseen (not logged) [] is the number of satellites that can theoretically be seen from the current position.

nbused (not logged) [] is the number of satellites actually used to compute the position.

HDOP (not logged) [] is the GPS horizontal dilution of precision.

VDOP (not logged) [] is the GPS positional dilution of precision.

PDOP (not logged) [] is the GPS vertical dilution of precision.

time (not logged) []

YYYYMMDD-hhmmss-satelliteinfo-usbl_JC1.gps (not logged by Level-C)

Additional information from the Fusion USBL system regarding the GPS position fix quality. Most of this data does not contain meaningful value and is generated because a GPS logging module is used to log the USBL NMEA GGA output.

nbseen (not logged) [] contains no meaningful data.

nbused (not logged) [] contains no meaningful data and is always 12.

HDOP (not logged) [] is the semi-major axis value for the fix of the beacon's position in metres.

VDOP (not logged) [] contains no meaningful data.

PDOP (not logged) [] contains no meaningful data.

time (not logged) []

YYYYMMDD-hhmmss-sb_depth-EM120_JC1.depth (em120cb)

This data file contains the depths logged by the centre beam of the EM120 multi-beam echo sounder. The data has been corrected for sound velocity and the cruise report should be consulted for details of the corrections applied. The depths have not been corrected for tidal height.

snd (depth) [metre] is the depth measured by the EM120 multi-beam sonar from the sea bed to the sea surface. No compensation is made for the current tidal height.

freq (not logged) [kilohertz] is the sound frequency used to make the depth measurement. -1 indicates that the frequency was not included in the telegram from the echo sounder.

time (not logged) []

YYYYMMDD-hhmmss-shipattitude-Aplanix_TSS_JC1.att (posmvts)

This data file contains data from the Aplanix POSMV system's Motion Reference Unit (MRU).

measureTS (not logged) [] is the time stamp applied to the data by the POSMV.

head (heading) [degree] is the true bearing that the bow of the vessel is pointing at.

roll (roll) [degree] is the roll angle of the vessel. A positive angle indicates that the port side of the vessel is above the starboard side.

pitch (pitch) [degree] is the pitch of the ship. A bow up rotation gives a positive pitch value.

heave (heave) [metre] is the vertical variation in height of the reference point on top of the POSMV MRU. Positive values indicate the reference point has risen above its stationary position. Please see the POSMV documentation for details of the filtering applied to the MRU data to calculate this value.

mode (not logged) [] is a quality indicator of the heading data. 0 indicates that the calculation of the heading was performed without any GPS aid, 1 indicates the heading calculation was aided by the GPS and 2 that it was aided by GPS and GAMS.

time (Time) []

YYYYMMDD-hhmmss-shipattitude-Seapath200AT_JC1.att (sb-att)

This data file contains data from the Seapath 200 system's Motion Reference Unit (MRU).

measureTS (not logged) [] is the time stamp applied to the data by the Seapath 200.

head (heading) [degree] is the true bearing that the bow of the vessel is pointing at.

roll (roll) [degree] is the roll angle of the vessel. A positive angle indicates that the port side of the vessel is above the starboard side.

pitch (pitch) [degree] is the pitch of the ship. A bow up rotation gives a positive pitch value.

heave (heave) [metre] is the vertical variation in height of the reference point on top of the POSMV MRU (the Seapath's data is referenced to the POSMV MRU). Positive values indicate the reference point has risen above its stationary position. Please see the Seapath 200 documentation for details of the filtering applied to the MRU data to calculate this value. This variable in the RVS data stream may have every value as 0.

mode (not logged) [] is a quality indicator of the heading data. 0 indicates that the calculation of the heading was performed without any GPS aid, 1 indicates the heading calculation was aided by the GPS and 2 that it was aided by GPS and GAMS.

time (Time) []

YYYYMMDD-hhmmss-shipattitude_aux-Aplanix_TSS_JC1.att (posmvts)

This data file contains data from the Aplanix POSMV system's Motion Reference Unit (MRU).

acX (not logged) [] is not valid data.

acY (not logged) [] is not valid data.

acZ (not logged) [] is not valid data.

hunc (acc_hdg) [degree] is the heading uncertainty determined by the POSMV MRU.

runc (acc_roll) [degree] is the roll uncertainty determined by the POSMV MRU.

punc (acc_ptch) [degree] is the pitch uncertainty determined by the POSMV MRU.

time (Time) []

YYYYMMDD-hhmmss-shipattitude_aux-Seapath200AT_JC1.att (sb-att)

The logging module for the Seapath 200 system is based upon the POSMV's data logging module. This file is generated automatically but does not contain any valid data. The **accroll**, **accpitch** and **accchdg** variables do exist in the RVS Level-C stream, but every value is set to 0.0.

Not logged by Techsas (relmov)

This RVS Level-C post processed file contains details of the motion of the vessel and is used by other Level-C post-processing streams. This file is generated from a gyro and log. The cruise documentation should be consulted to find which log and gyro source were used.

not logged (vn) [knot] is the north component of the vessel's velocity.

not logged (ve) [knot] is the east component of the vessel's velocity.

not logged (pfa) [knot] is the vessel's speed in the fore direction.

not logged (pps) [knot] is the vessel's speed in the port direction.

not logged (pgyro) [degree true] is the vessel's average heading.

time (Time) []

Not logged by Techsas (bestnav)

This RVS Level-C post processed file was written when satellite positioning was in its infancy and there could be long periods of time between fixes. The program bestnav reads position fixes from up to three RVS data files along with the ship's motion as calculated by relmov and generates a series of positions at time intervals of the navigation window. The cruise report should be consulted to find the source of the three position fixes used.

The basis for the program's calculations is a series of position fixes. The input fix files are given in order and a timeout given for each file. Fixes will be taken from the first file until a data gap longer than that file's timeout is encountered. Fixes will then be taken from the second file until either the first file resumes or the second file also times out. In the latter case the third file will be used.

The gaps in the series of fixes are next filled using dead-reckoning based on the ship's motion relative to the water. When the end of each gap is reached the position obtained by dead-reckoning is compared with the fix position and the difference between the positions attributed to drift, caused either by wind or water currents. The drift in position is used to calculate an average drift velocity during the fix gap whose magnitude is compared with the known drift and maximum allowable drift entered on the menu. If the drift is greater than the limit then the fix is assumed to be in error and processing is halted. If this occurs the user should either correct (or delete) the fix or increase the allowed drift and re-run the program.

If an acceptable drift velocity is found this is added to the dead reckoned positions. This completes the calculation of the ship's track. For each navigation window a position is interpolated from the calculated track and a record written to the output fixes file. Each record also contains the calculated velocity represented as north and east components and as speed made good and course made good. The average heading of the ship is calculated along with a cumulative distance since the start of the file. If the output file contains a variable stream this will be set to 1, 2 or 3 to indicate which of the fix files the current fix was taken from. The status of the calculated values will either be good, if there was a fix at the time of the output record, or interp otherwise.

not logged (lat) [degree] is the vessel's calculated latitude.

not logged (lon) [degree] is the vessel's calculated longitude.

not logged (vn) [knot] is the north component of the vessel's velocity.

not logged (ve) [knot] is the east component of the vessel's velocity.

not logged (cmg) [degree] is the vessel's course made good.

not logged (smg) [knot] is the vessel's speed made good.

not logged (dist_run) [degree] is the distance that the vessel has run since the start of this bestnav file.

not logged (heading) [degree] is the vessel's heading.

time (Time) []

Not logged by Techsas (bestdrf)

The drift velocities calculated by the bestnav program are also written to the bestdrf file. This contains either one record per navigation window (if there is more than one fix in the window) or one record per fix. The file contains the north and east calculated drift velocities as well as the known and limit drift speeds entered on the menu.

not logged (vn) [knot] is the north component of the vessel's drift.

not logged (ve) [knot] is the east component of the vessel's drift.

not logged (kvn) [knot] is the known north velocity entered in the relmov menu.

not logged (kve) [knot] is the known east velocity entered in the relmov menu.

time (Time) []

Not logged by Techsas (prodep)

The prodep post-processing file takes echo sounder depths that have been logged with a fixed sound velocity of 1500 ms-1 and corrects them for typical sound velocities for that geographical area using Carter's tables by the Hydrographic Office.

not logged (uncdepth) [metre] is the uncorrected depth.

not logged (cordepth) [metre] is the corrected depth.

not logged (cartarea) [] is the number of the Carter area used for the correction.

time (Time) []

Not logged by Techsas (pro_wind)

The Level-C windcalc post-processing program takes the bestnav and surfmet Level-C files and calculates the absolute wind speed and direction.

not logged (abswpsd) [knot] is the absolute wind speed at the height of the anemometer.

not logged (abswdir) [degree true] is the absolute wind direction.

time (Time) []