



RESEARCH EXPEDITION REPORT

RRS *James Cook* Expedition JC237

6 AUGUST – 4 SEPTEMBER 2022

CLASS – Climate-linked Atlantic Sector Science
Whittard Canyon and Porcupine Abyssal Plain
Fixed Point Observatories

Principal Scientist

V A I Huvenne

2022

Report Number 80

© National Oceanography Centre, 2024

Document Data Sheet

Author HUVENNE, V.A.I.	Publication Date 2024
Title <i>RRS James Cook Expedition 237, 6 August – 4 September 2022. CLASS – Climate Linked Atlantic Sector Science: Whittard Canyon and Porcupine Abyssal Plain Fixed Point Observatories</i>	
Reference Southampton, UK: National Oceanography Centre, Southampton, 323p (National Oceanography Centre Research Expedition Report, No. 80)	
Abstract <p>JC237 was one of the main expeditions of the CLASS National Capability programme funded by NERC (UK). Delayed by two years as a result of the COVID-19 pandemic, the expedition combined two important pieces of observational work for the CLASS programme.</p> <p>The main aim of the cruise was to revisit key sites, last surveyed on JC125 in 2015, in the Whittard Canyon system on the Celtic Margin. This submarine canyon, and its protected area (The Canyons Marine Conservation Zone in English waters) is one of the long-term benthic time-series locations of the CLASS programme. The goal of the survey was to increase our understanding of benthic ecosystem change and recovery in the deep sea, under either natural (e.g. sediment flows, flank collapses) or anthropogenic (e.g. bottom trawling) environmental disturbance. Furthermore, the new datasets expand the general knowledge on the geological framework, sediment dynamics, current regimes and habitat distributions in land-detached submarine canyons – important connecting pathways between shelf and deep sea.</p> <p>The second CLASS-related aim was to carry out photographic surveys at the Porcupine Abyssal Plain Sustained Observatory (PAP-SO) – the longest-running deep-water observatory worldwide. Annual observations at this location create an invaluable record. The availability of an ROV (first time for the PAP-SO site) and a deep-water AUV (only second visit) during JC237 opened new opportunities for detailed sampling and extensive imaging of the benthic community.</p> <p>In addition, JC237 also had a technical demonstrator/development component: it was the first science expedition for the brand-new Autosub5 deep-water AUV and for the DeepGlider from MARS (the Marine Autonomous and Robotics Systems division at NOC). Furthermore, the Autosub5 was equipped with the new RoCSI eDNA sampler, enabling in-situ sampling and preservation of eDNA at depths up to 4500m. This demonstrator was part of the iAtlantic project.</p> <p>Overall, the expedition was a great success, with an extensive amount of data and samples collected (15 AUV missions with >250,000 photographs, 700k sidescan & multibeam, 60 RoCSI samples; 17 ROV dives, 45 days of DeepGlider observations, 21 CTD casts, 5 megacores, 12 gravity cores, 4 CPR transects and 10s of km² of shipboard multibeam data collected). First interpretations have already illustrated coral expansion in some locations in the canyon, while geomorphological change seems limited.</p> <p>KEYWORDS Submarine Canyon, The Canyons Marine Conservation Zone, Porcupine Abyssal Plain, Autonomous Underwater Vehicle, Remotely Operated Vehicle, Habitat Mapping</p>	
Issuing Organisation National Oceanography Centre, European Way, Southampton SO14 3ZH UK Email: publications@noc.ac.uk nol@noc.soton.ac.uk A pdf of this report is available for download at: http://eprints.soton.ac.uk	

(This page is intentionally left blank)

Contents

PARTICIPANTS	1
1.1. SCIENTIFIC PERSONNEL.....	1
1.2. SHIPS OFFICERS AND CREW	1
2. ITINERARY	3
3. BACKGROUND AND SCIENTIFIC RATIONALE.....	4
3.1. Project framework	4
3.1.1. CLASS programme: sustained observations and technological development	4
3.1.2. iAtlantic.....	5
3.2. Study areas	5
3.2.1. Whittard Canyon.....	5
3.2.2. Porcupine Abyssal Plain (<i>Brian Bett</i>)	10
3.3. New technologies: RoCSI (<i>Susan Evans</i>).....	11
4. OBJECTIVES	12
4.1. Whittard Canyon & The Canyons MCZ	12
4.2. Porcupine Abyssal Plain	13
4.3. Additional aims and objectives to support collaborative work with other institutes and research groups	14
5. NARRATIVE.....	15
6. METHODS AND INITIAL RESULTS	27
6.1. Acoustic mapping & profiling (<i>Tim Le Bas, Catherine Wardell</i>).....	27
6.1.1. Shipboard Multibeam Systems: EM122 and EM710 Bathymetry & Backscatter (<i>Catherine Wardell, Tim Le Bas</i>)	27
6.1.2. Shipboard SBP System	28
6.1.3. Autosub5 Multibeam Bathymetry & Backscatter (<i>Tim Le Bas, Catherine Wardell</i>).....	28
6.1.4. Autosub5 Sidescan (<i>Catherine Wardell, Tim Le Bas</i>).....	41
6.1.5. Autosub5 SBP (<i>Catherine Wardell, Tim Le Bas</i>).....	46
6.1.6. ISIS Multibeam Bathymetry & Backscatter (<i>Veerle Huvenne, Tim Le Bas, Catherine Wardell</i>)	47
6.2. Video surveying and photography (<i>Brian Bett, James Strong, Veerle Huvenne</i>)	55
6.2.1. ROV-based video surveying	55
6.2.2. Autosub5-based photography (<i>Brian Bett</i>)	79
6.2.3. Bathysnap recovery (<i>Brian Bett</i>).....	92
6.3. Biological sampling (<i>Brian Bett</i>).....	94
6.3.1. Live <i>Desmophyllum pertusum</i> Sampling.....	99

6.3.2.	Fossil coral sampling	99
6.3.3.	Sampling for Taxonomy and Identification	100
6.3.4.	Occurrence of desaturase genes in deep-sea fauna	102
6.3.5.	Free-living nematodes associated with symbiotic bacteria in the Whittard Canyon	102
6.4.	Settling experiment (<i>James Strong</i>)	104
6.5.	Coring (<i>Esther Sumner, Michael Clare</i>).....	105
6.5.1.	ROV pushcores.....	105
6.5.2.	Gravity Coring	105
6.5.3.	Megacoring	106
6.6.	Geological observations (<i>Gareth Carter, Silvia Ceramicola</i>).....	106
6.6.1.	Geological highlights from ROV dives.....	106
6.7.	eDNA & RoCSI (<i>Susan Evans, Nathan Hubot</i>)	112
6.7.1.	RoCSI	113
6.7.2.	CPR.....	114
6.7.3.	Water Sampling from CTD	115
6.7.4.	Water sampling from the ROV.....	117
	Processing methodology.....	119
6.8.	Water column observations (<i>Rob Hall</i>)	120
6.8.1.	CTD.....	120
6.8.2.	Shipboard ADCP	125
6.8.3.	Deep Glider	126
6.9.	Outreach activities (<i>Luis Greiffenhagen, Lisa Skein, Vikki Gunn</i>)	129
7.	EQUIPMENT & SAMPLING REPORTS.....	132
7.1.	Autosub5 Cruise Report.....	132
7.1.1.	Introduction	132
7.1.2.	Autosub5 Team.....	134
7.1.3.	AUV Configuration	134
7.1.4.	JC237 Summary.....	135
7.1.5.	Faults/Issues	135
7.1.6.	Mission Summaries.....	138
7.1.7.	AUV Data.....	141
7.1.8.	Missions	145
7.1.9.	Autosub5 Measurements	234
7.1.10.	Autosub5 Co-ordinate frame	238

7.2.	ISIS ROV Technical Report	239
7.2.1.	Mobilisation	239
7.2.2.	De-Mobilisation	239
7.2.3.	Operations	239
7.2.4.	ROV External and Sampling Equipment.....	242
7.2.5.	Isis ROV	245
7.2.6.	ROV Topside Systems	250
7.2.7.	Isis ROV Dive Summary	257
7.2.8.	ISIS Dive metadata	258
7.2.9.	ROV Vehicle Specification.....	260
7.3.	Coring Technical Report.....	261
7.3.1.	Gravity corer	261
7.3.2.	Megacorer.....	262
7.4.	CTD.....	263
7.4.1.	CTD Summary	263
7.4.1.1.1	Instrument Package	264
7.4.2.	Workhorse 300 kHz LADCP	276
7.4.3.	Stand-Alone Pumps (SAPs)	279
7.4.4.	Salinometry.....	281
7.4.5.	Software Used.....	284
7.5.	Deep Glider	285
7.5.1.	Deep Glider background information (from DY152 cruise report)	285
7.5.2.	Technical specifications (from DY152 cruise report).....	286
7.6.	Ship-fitted Systems	287
7.6.1.	Scientific computer systems	287
7.6.2.	Instrumentation	290
8.	REFERENCES.....	301
9.	STATION LIST.....	305
10.	MAPS.....	312

PARTICIPANTS

1.1. SCIENTIFIC PERSONNEL

name	surname	institute	Role
Veerle	Huvenne	NOC	PSO
James	Strong	NOC	Co-PSO/watch leader
Tim	Le Bas	NOC	Mapping expert/watch leader
Brian	Bett	NOC	Benthic Biologist
Catherine	Wardell	NOC	Mapping expert
Susan	Evans	NOC	eDNA expert
Nathan	Hubot	NOC	eDNA expert
Esther	Sumner	USoton	Sedimentologist
Gareth	Carter	BGS	Geologist
Silvia	Ceramicola	OGS	Geologist
Josh	Tate	JNCC	Conservation policy rep, whale watchier
Robert	Hall	UEA	Oceanographer
Luis	Greiffenhagen	NOC volunteer	CLASS volunteer
Lisa	Skein	SANBI	iAtlantic volunteer
Russell	Locke	NMF-MARS	ROV/TLO
Dave	Turner	NMF-MARS	ROV
Josue	Viera	NMF-MARS	ROV
Stephen	McDonagh	NMF-MARS	ROV
Emre	Mutlu	NMF-MARS	ROV
Martin	Yeoman	NMF-MARS	ROV
William	Handley	Contractor	ROV
Matthew	Kingsland	NMF-MARS	Autosub
Richard	Austin-Berry	NMF-MARS	Autosub
Konrad	Ciaramella	NMF-MARS	Autosub
Alberto	Consensi	NMF-MARS	Autosub
Eoin	O'Hobain	NMF-MARS	Autosub
Richard	Philipps	NMF-MARS	Coring
Dougal	Mountifield	NMF-MARS	CTD/gliders
Eleanor	Darlington	NMF-MARS	IT/Ship Systems

1.2. SHIPS OFFICERS AND CREW

John	Leask	Master
Iain	Macleod	Chief Officer
Bryn	Beaurain	2 nd Officer
Jordan	Greenhow	3 rd Officer
Keith	Sneddon	Chief Engineer
Keith	Richie	2 nd Engineer
John	Lee	3 rd Engineer
George	Palmer	3 rd Engineer
David	Hawksworth	ETO
Paula	McDougal	Purser
Mark	Squibb	Chief Petty Officer - Scientific
William	McLennan	Chief Petty Officer - Deck
John	Hopley	Chief Petty Officer – Scientific
Peter	Smyth	Petty Officer - Deck

David	Bergin	Engine Room Petty Officer
Oleg	Avdejev	Seaman Grade 1A
Robert	McKeown	Seaman Grade 1A
Wayne	Critten	Seaman Grade 1A
Michael	Leigh	Head Chef
Coleen	Hayward	Chef
Denzil	Williams	Assistant Steward

2. ITINERARY

Departure Southampton: 6 August 2022, time: 11:00 BST
Arrival Southampton: 4 September 2022, time: 16:50 BST

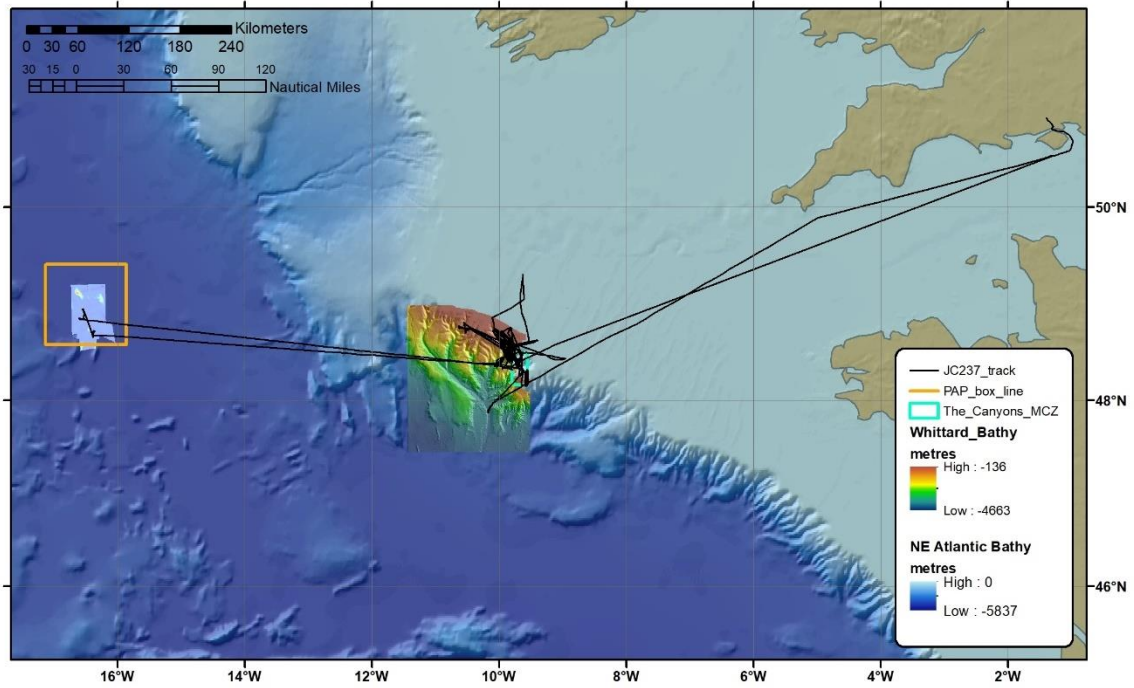

Fig. 2.1 Cruise track chart

3. BACKGROUND AND SCIENTIFIC RATIONALE

Expedition JC237 was one of the main flagship expeditions of the CLASS 'Fixed Point Observatories' programme, and aimed at revisiting the benthic ecosystems of the Whittard Canyon and the Porcupine Abyssal Plain. At the same time, the cruise also had a component of technological development with the demonstration of the RoCSI system mounted in the Autosub5 AUV, collecting eDNA samples in parallel with more traditional habitat mapping data such as multibeam bathymetry, sidescan sonar and photography. This aspect of the cruise was part of the iAtlantic project.

3.1. Project framework

3.1.1. CLASS programme: sustained observations and technological development

CLASS (Climate Linked Atlantic Sector Science; <https://projects.noc.ac.uk/class/>) is the National Capability Single Sector Marine Research Programme funded by NERC for the period 2018-2023. It aims to deliver the knowledge and understanding of the Atlantic Ocean system that society needs to make evidence-based decisions regarding ocean management. CLASS will address key knowledge gaps in the understanding of ocean variability, climate regulation and ocean services, and will assess how the ocean will evolve as a result of climate change and intensified human exploitation.

CLASS is being delivered through the combination of an Atlantic focussed science programme, and a series of activities that underpin Marine Science within the UK: sustained ocean observations in the Atlantic, world class model development, and state of the art technology.

The objective behind the CLASS sustained ocean observations is to create and expand multi-decadal records of ocean parameters that provide insights in the temporal evolution of the Atlantic, from the surface to the seafloor, and from the coast to the deep sea. The programme includes a number of repeat transects across the Atlantic, a number of fixed-point water column observatories, and a number of repeat seafloor & habitat monitoring sites. The latter include sites from the shelf (Western Channel Observatory, Haig Fras Marine Conservation Zone), slope (Darwin Mounds Marine Protected Area, Whittard Canyon & The Canyons Marine Conservation Zone) and abyssal plain (Porcupine Abyssal Plain), which are surveyed on a regular basis (yearly for the WCO and PAP, every 3 years for Haig Fras, every 5 years for Whittard Canyon and every 8 years for the Darwin Mounds).

As part of the science programme within CLASS, the results of those repeat surveys will be used to create an improved understanding of the role and impact of abrupt seafloor disturbances on benthic communities, including their resilience and recovery; looking both at natural and anthropogenic disturbance events. The impact of human activities in the marine environment is extensive and increasing, as countries around the world develop their blue economies. Direct impacts, such as fishing, drilling, mining or the construction of seafloor installations, can have long-term effects on benthic communities, exceeding the natural levels of variability and disturbance those communities are adapted to. However, because direct impacts are often related to specific events or pressures, direct impacts are often manageable through marine spatial planning, such as the designation of fishery closures or establishment Marine Protected Areas. Correct information and knowledge about the long-term evolution and/or recovery of benthic systems following major disturbances hence is paramount to support effective marine spatial planning.

The work during JC237 covered two aspects of the CLASS programme for 2022: the revisit of the Whittard Canyon system (including The Canyons MCZ) and the annual seafloor imagery work at the Porcupine Abyssal Plain.

3.1.2. iAtlantic

iAtlantic (www.iatlantic.eu) is a multidisciplinary research project funded by the EU Horizon2020 research and innovation programme (Grant No 818123) seeking to assess the health of deep-sea and open-ocean ecosystems across the full span of the Atlantic Ocean. The project aims to deliver knowledge that is critical for responsible and sustainable management of Atlantic Ocean resources in an era of unprecedented global change. Involving marine scientists from countries bordering the north and south Atlantic Ocean, this ambitious project will determine the resilience of deep-sea animals – and their habitats – to threats such as temperature rise, pollution and human activities.

iAtlantic is undertaking an ocean-wide approach to understanding the factors that control the distribution, stability and vulnerability of deep-sea ecosystems. Work spans the full scale of the Atlantic basin, from the tip of Argentina in the south to Iceland in the north, and from the east coasts of USA and Brazil to the western margins of Europe and Africa. Central to the project's success is the international collaboration between scientists throughout the Atlantic region, with sharing of expertise, equipment, infrastructure, data and personnel placed at the forefront of iAtlantic's approach.

The project has an important technological development component, focusing on the development of new technologies that underpin the mapping of Atlantic deep-sea ecosystems. Besides the development and testing of new camera systems, and the integration of Machine Learning into the workflows, iAtlantic also included the demonstration of NOC's new RoCSI eDNA sampler, deployed at depth in a survey AUV. This demonstration action was included in expedition JC237.

3.2. Study areas

3.2.1. Whittard Canyon

3.2.1.1. Geology (*Gareth Carter, Silvia Ceramicola*)

Along the Celtic Margin, in the NE Atlantic, the Whittard Canyon stands out as one of the largest submarine canyons. From ~200 m water depth at the shelf break, the dendritic system deeply incises into the continental slope forming four main branches which converge at a junction point ~3,600 m below sea level. From there, the Whittard Channel continues downslope, eventually giving way to the Celtic Fan which comprises the major sediment depocentre for the system (Zaragosi *et al.*, 2000; Bourillet *et al.*, 2006).

The Whittard Canyon was incised into the continental slope of the Celtic Margin during the Pliocene-Pleistocene, primarily through the mass wasting of the slope and subsequent retrogressive failure of the associated headscarps, with canyon incision being amplified and enhanced during periods of sea level lowstands (Amaro *et al.*, 2016). The latest period of channel incision occurred during the last glacial period (Devensian in British terms, equating to the Weichselian of Northern Europe) when the shelf break was connected to palaeoriver systems comprising fluvial sources from the Celtic Sea region and Fleuve Manche (Toucanne *et al.*, 2008; Amaro *et al.*, 2016). Meltwater pulses, triggered by periods of increased ice sheet wasting and retreat, significantly increased the glacially-derived sediment load delivered to the margin through these fluvial networks, resulting in phases of high turbiditic activity (i.e. periods of erosive sediment gravity flows) aiding in the carving of the canyon branches between 20-14 ka (Toucanne *et al.*, 2008). From 14 ka onwards, sea levels had risen to a point whereby significant sediment transfer to the margin was precluded and erosive turbiditic activity was effectively shut off along the Celtic Margin (Toucanne *et al.*, 2008). Although turbidity currents

are known to still occur through the Whittard Canyon system (see Heijnen *et al.*, 2022), canyon erosive activity is greatly reduced at present due to the expanse of continental shelf separating the margin from currently active fluvial systems and associated significant sediment sources, resulting in the Whittard Canyon becoming a land-detached submarine canyon system.

Whilst major canyon incision is not thought to be significant at present, changes to the canyon slope morphology are still ongoing through erosional and mass failure processes. Block falls and spalling erosion are known to occur along the exposed bedrock terraces and rockwalls that form the steeper canyon slopes, primarily due to the geomechanical properties (e.g. joint set orientations) of the bedrock units (Carter *et al.*, 2018). Bioerosion may also play a role in undermining stiff clay and weak mudstone terraces, and may increase exfoliation erosion of carbonate surfaces (Carter *et al.*, 2018). In addition to the ongoing, relatively small-scale erosion of rock slopes, active retrogressive failure of headscarps around the head of the canyons has been well-documented and is thought to have occurred since the Last Glacial Maximum, ~21 ka (Cunningham *et al.*, 2005). This process results in the formation of ‘amphitheatre’ or ‘cauliflower’ morphological features that can be observed in present-day bathymetry across the area of the canyon head (Stewart *et al.*, 2014).

The Early-Cretaceous rifting episode, associated with the opening of the North Atlantic, produced the geological framework that underpins the present-day Celtic Margin (Evans, 1990). The post-rift stratigraphic succession, subsequently incised by the canyon activity, has been reconstructed from borehole and seismic data by several authors, and is briefly summarized below:

- **Cretaceous Chalk:** The Lower (Early) Cretaceous strata consist of a thin sequence of shallow-marine clastics resting unconformably on Permo-Triassic or Jurassic sediments. The opening of the North Atlantic resulted in sea level rise which changed the depositional environment from shallow- to deep-marine, leading to the deposition of a thick Chalk sequence during the Upper (Late) Cretaceous and Paleocene (Evans, 1990). The Santonian (Upper Cretaceous, ~86.3-83.6 Ma) section typically consists of white chalk interbedded with limestone and tan, glauconitic siltstone, which passes upward into a more ubiquitous/blanket, relatively soft (often clay-like) chalk (Evans, 1990). Glauconitic units can form a hardground at the base of the Upper Cretaceous section in places along the margin (e.g. the Goban Spur margin). The top of the Upper Cretaceous is thought to be located more than 1000 m below sea level in the study area (Evans, 1990).
- **Jones Formation:** The Jones Formation rests unconformably on Paleogene strata (primarily limestones and mudstones), laid down during the “alpine inversion event” as a prograding, deltaic wedge of early to mid-Miocene age (Stewart *et al.*, 2014). It consists of progradational calcilutites with up to 25% sand-sized particles, deposited on a shelf with relatively uniform rates of deposition (Evans & Hughes, 1984; Stewart *et al.*, 2014). In boreholes recovered from the shelf, the Jones Formation has proven to be a uniform, olive-grey, intensely bioturbated, silty **calcilutite** which grades locally into slightly coarser bands a few centimetres thick (Evans & Hughes, 1984). In seismic data, the Jones Formation exhibits reasonably parallel, continuous reflectors with several prominent reflectors located towards the top of the unit; across the interflues between the Explorer and Dangeard canyons, the top of this formation sits at approximately 250 m below seafloor – mbsf (Stewart *et al.*, 2014).
- **Cockburn Formation:** An erosive, undulating unconformity separates this formation from the underlying Jones Formation, likely representing an increase in hydrodynamic power along the Celtic Margin during the mid- to late Miocene (Evans & Hughes, 1984; Stewart *et al.*, 2014). Boreholes recovered from the shelf show the Cockburn Formation to be a deltaic, possibly

tidal, sequence of uniform, light olive-grey, moderately well sorted, bioturbated, structureless, unconsolidated, silty **calcarenite** with a carbonate content generally in excess of 80% (Evans & Hughes, 1984; Stewart *et al.*, 2014). Fine to very fine sand dominates the grain size which contrasts with the underlying Jones Formation where the silt range dominates the grain size (Evans & Hughes, 1984). Around the shelf break, the Cockburn Formation has a thickness in excess of 150 m, and seismic reflectors can be seen to downlap onto the sub-parallel reflectors of the underlying Jones Formation (Stewart *et al.*, 2014).

- **Little Sole Formation:** Stewart *et al.* (2014) informally divide the Little Sole Formation into three units; Unit 1 consists of a discontinuous slump and palaeovalley infill deposit, Unit 2 consists of a sheet-like deposit (~50-60 m thick) resting unconformably on the underlying Cockburn Formation, and Unit 3 comprising a discontinuous wedge-shaped member present only on the continental slope. Unit 3 can be completely absent where canyon incision is particularly pronounced but is preserved across the smooth canyon interfluvies (Stewart *et al.*, 2014). Very little information is available on dominant lithologies for each unit, however Evans & Hughes (1984) report an olive-grey clayey sand associated with the sheet-like deposit (Unit 2), with nanofossils that indicate deposition occurred in water depths of greater than 50 m.

3.2.1.2. **Sediment transport (Esther Sumner, Michael Clare)**

Whittard Canyon is a land-detached submarine canyon system, with canyon heads currently approximately 300 km from the nearest coastline. Thus, sediment supply into the canyon system is more limited than at times of lower sea level, and during deglaciation, when sediment supply was higher due to proximity of the canyon to fluvial systems (Zaragosi *et al.*, 2006). This is evident in sediment cores previously collected from this canyon system. These sediment cores typically contain abundant thin bedded, organic-rich turbidites deposited during the Pleistocene, overlain by dominantly hemipelagic sediments deposited during the Holocene (Huvenne *et al.*, 2016). Current sediment supply to the canyon system is likely to be tidal reworking of glacial sandbanks on the continental shelf around canyon heads (Praeg *et al.*, 2015) and sediment eroded internally from the canyon walls. Interestingly, sediment waves located immediately above the canyon headwalls indicate that in some cases, the dominant net sediment transport direction may be out of the canyon, rather than directed into the canyon (Lo Iacono *et al.*, 2020).

In the present day, sediment transport within the canyon system is dominated by tidal flows and sediment-laden gravity currents. Tidal flows have velocities of up to ~0.5 m/s (Hall *et al.*, 2017) in an up and down canyon direction, whereas less frequent sediment-laden gravity currents have ADCP measured velocities of up to 5.0 m/s (Heijnen *et al.*, 2022). Recent direct monitoring of sediment gravity currents in the Eastern Branch of Whittard Canyon recorded six gravity currents within a one-year period; this is higher than previously expected for a land-detached canyon system (Heijnen *et al.*, 2022). These episodic gravity currents, combined with daily tidal flow provide a mechanism to distribute sediment, pollutants (e.g. microplastics) and nutrients (e.g. carbon) throughout the canyon system.

3.2.1.3. **Oceanography (Rob Hall)**

The steep, complex bathymetry of Whittard Canyon makes it an important site for the exchange of water masses, nutrients and carbon between the deep North Atlantic and shallow Celtic Sea. Along smooth, gently sloping continental margins the Taylor-Proudman theorem dictates that geostrophic

flow is along-slope, with little capacity for cross-shelf exchange. However, where the continental slope is steep and the slope orientation changes rapidly, such as where the shelf is incised by a submarine canyon, unstable geostrophic cross-slope flows can develop, characterised by high Rossby numbers. These canyon-initiated upwellings and downwelling are likely globally important for shelf sea biogeochemical cycles and ecosystem function due to the ubiquity of submarine canyons worldwide. Submarine canyons are also known conduits for dense water cascades and turbidity currents from the continental shelf to the deep ocean, facilitating off-shelf fluxes of carbon.

In the Whittard Canyon region there is convincing evidence (e.g. Porter et al. 2016) that when the slope current is towards the southeast it drives an upwelling cross-slope flow through the Eastern Limb of Whittard and Explorer Canyon that is a considerable source of nitrate to the Celtic Sea.

Steep, complex bathymetry typical of submarine canyons also creates an ideal environment for the generation of energetic internal tides (internal gravity waves forced by tidal motions). Depending on the canyon's geomorphology and local stratification, these internal tides may propagate away (either into deep water, onto the continental shelf, or both) or become focused within the canyon and dissipate locally. In some locations, where the bathymetric slope matches the geometry of internal tide propagation, the dissipation mechanism is similar to surface waves breaking on a beach. In other locations, where the bathymetric slope is steeper, the internal tide will reflect and scatter to higher modes, increasing current shear and creating dynamic instabilities. With both dissipation mechanisms, some of the energy is transferred to turbulent mixing which can drive a vertical flux of nutrients into the photic zone – one explanation to why the shelf breaks near submarine canyons are typically highly productive regions. As internal tide generation, propagation and dissipation is dependent on local stratification as well as bathymetric slope gradient, the dynamics of internal tides varies considerably between canyons and also temporally within individual canyons. In addition, internal tide focusing is expected to impact sediment resuspension and transport, through the mechanism of enhanced near-bottom tidal flows.

In the Whittard Canyon region, including the proximate continental shelf, semidiurnal internal tides have been observed in hydrographic mooring timeseries (Hopkins et al. 2014), with autonomous ocean gliders (Hall et al. 2017), and simulated using regional numerical models (Vlasenko et al. 2016; Aslam et al. 2018). However, a thorough assessment of the Whittard Canyon internal tide field with its likely spatially and temporally variable dynamics, and direct measurements of the turbulent mixing and vertical nutrient fluxes driven by its dissipation are both currently lacking.

3.2.1.4. Habitats, species distribution and anthropogenic impacts (Veerle Huvenne, Brian Bett)

As is the case with many submarine canyons, Whittard Canyon can be considered a biodiversity hotspot, with a high faunal abundance in places (Amaro et al., 2016), and a high diversity, particularly in the epibenthic megafauna. Predictive species distribution models indicate that the main driving factors behind increased species abundance and diversity are depth, slope, BPI, ruggedness and, if the information is available, current speed (Robert et al., 2015; Pearman et al., 2020), and that the highest diversity in epibenthic megafauna can be found in complex terrain, on ridges and vertical substrata, often associated with the presence of framework-forming scleractinian cold-water corals such as *Desmophyllum pertusum*, *Madrepora oculata*, or *Solenosmilia variabilis*. In how far these assemblages are related to the presence and activity of internal waves in the canyon, and how these (re)distribute the organic matter and food input for the fauna, is an active area of research (Pearman et al., 2023). Real vertical coral reefs have been discovered in the canyon, and specific habitat mapping techniques, based on novel configurations of multibeam systems in ROVs or AUVs, were developed as part of the

ERC CODEMAP project to map out their morphology and species distribution (Huvenne et al., 2011; Robert et al., 2017). Not all vertical substrata are covered in scleractinian reefs, though. Some are barren, others host assemblages based on octocorals (Morris et al., 2013), cerianthids or brachiopods (Pearman et al., 2023) or *Acesta excavata* clams and *Neopycnodonte zibrowii* oysters (Johnson et al., 2013). Given that the vertical walls in Whittard Canyon are prone to small scale failures (“spalling”, Carter et al., 2018), it appears that these assemblages may be affected more often by natural disturbance events than the less steep slopes or terraces in the canyon. What exactly is the frequency of the disturbance and how the ecosystem responds, is not clear. On the other hand, these vertical (or overhanging) assemblages are somewhat protected against excessive sedimentation load, and may form natural refugia from the impacts of bottom trawling, as no trawling takes place in those types of settings (Huvenne et al., 2011). The canyon interfluves, however, are heavily impacted by bottom trawling activities, which cause physical damage to the benthic fauna (Stewart et al., 2014; Pearman, 2020), but which also cause increased turbidity, which may cause additional sediment plumes that flow into the canyon branches (Wilson et al., 2015).

Another type of anthropogenic impact that has been noted in the canyon, is marine litter, particularly in the form of lost and discarded fishing gear (Hernandez, 2020). The extent and impact of marine litter is only now being assessed, but it is clear that lost nets and lines can keep fishing, while plastics easily get tangled in the coral habitats. On the long term, those plastics will break down into microplastics, and will be transported with sediment flows down the canyon system into deeper waters.

3.2.1.5. The Canyons Marine Conservation Zone (Josh Tate)

The UK Government and the Devolved Administrations are committed to establishing an ecologically coherent network of Marine Protected Areas (MPAs) in UK seas to meet international commitments and European obligations. The Marine and Coastal Access Act (2009) requires the UK Governments to create a network of MPAs that will comprise existing sites (European Marine Sites, SSSIs and Ramsar sites) together with new national designations. The Marine and Coastal Access Act makes provision for the designation of Marine Conservation Zones (MCZs) in the UK Marine Area (JNCC, 2013).

The Canyons MCZ was recommended by the Finding Sanctuary Regional MCZ Project, and was one of 31 sites proposed for MCZ designation in 2013. Following public consultation, Defra confirmed its intention to progress the site and The Canyons MCZ was designated in November 2013 (JNCC, 2013). The Canyons MCZ protects the only known area of cold-water coral reef in English waters and is one of two English MCZs that protect deep-water habitats. It comprises the upper reaches of two canyon limbs (Dangaard and Explorer Canyon) that feed into the Whittard Canyon system (Stewart et al., 2014). The site was designated for two features, ‘Deep-seabed’ and ‘Cold-water coral reefs’, based upon data from a Mapping European Seabed Habitats (MESH) project survey carried out in 2007 and UKSeaMap 2010 (McBreen et al., 2011; Davies et al., 2014). Both features were given a ‘recover’ conservation objective (JNCC, 2013). Upon review, data underpinning designation of the site were considered to provide limited evidence of the features. Therefore, further survey was needed and in partnership with Defra, NOC allocated vessel time for data collection within the MCZ as part of the JC124-6 surveys targeting the Whittard Canyon system in 2015 (Huvenne et al., 2016).

Further survey activities within the Canyons MCZ include an MPA monitoring survey (CEND0917) that was carried out by JNCC in partnership with Cefas in 2017 (Eggett et al., 2018). This survey aimed to gather data from across the site in order to form the first time point in an ongoing monitoring series. The report from this project is due to be published in the near future. In 2018 the Haig Fras MCZ and the Canyons MCZ Natural Environment Research Council (NERC) survey (JC166) acquired ROV transect and MBES data within the canyons MCZ, allowing ground truthing of areas previously un-surveyed

(Huvenne & Furlong, 2019). As a result of the additional evidence gathered from these post-designation surveys, two further features were added to the site designation in 2019, 'Coral gardens' and 'Sea-pen and burrowing megafauna communities'.

As of 13th June 2022 new fisheries management measures were implemented within the majority of The Canyons MCZ. The new byelaw prohibits the use of bottom towed fishing gear, including demersal seines, and anchored nets and lines in order to conserve the designated features of the site.

Data collected from within the Canyons MCZ during the JC237 cruise will be of benefit to JNCC in order to expand the evidence base from the site, especially with regards to extent and distribution of cold-water coral reef features, for which evidence is currently restricted to a very small area of the site on the northern flank of Explorer Canyon. The potential to identify and describe other habitats and features of conservation interest (FOCI) present is also an exciting prospect that may contribute to the network-wide evidence base of the MCZ programme. Further background, data, and reports on the canyons MCZ can be found on the [JNCC information page](#).

3.2.2. Porcupine Abyssal Plain (*Brian Bett*)

The Porcupine Abyssal Plain Sustained Observatory (PAP-SO) is a long-term time-series study site operated by the NOC and its forerunner organisations since 1985 (Thurston, 1986). When the PAP-SO was established, it was located at a mid-point linking research programmes in the Porcupine Seabight and the BIOTRANS site (Biologischer Vertikaltransport und Energiehaushalt in der bodennahen Wasserschicht der Tiefsee; see e.g., Thiel et al., 1989). Major research findings in the first 20 years of operation included the discovery of a seasonal input of detritus to the seabed (Billett et al., 1983), and links between interannual detrital supply and benthic community structure (Billett et al., 2001; Billett et al., 2010). The observatory has been the focus for three special issue publications (Billett & Rice, 2001; Lampitt et al., 2010; Hartman et al., 2021), with foundation elements of the benthic programme having been introduced in an earlier publication (Rice et al., 1994). Benthic operations at the PAP-SO have typically included collection of megabenthos specimens by epibenthic sledge and/or otter trawl, scavenging amphipods by baited trap, meio- and macrobenthos by coring, and the use of time-lapse photography of the seabed to monitor intra- and interannual variation in phytodetritus deposition and benthic activity (Bett et al., 2001; Bett, 2003).

Over time, however, the suspicion has arisen that scientific trawling has influenced the ecology of megabenthic populations. This issue was first addressed by Billett et al. (2010) in a comparison of otter trawl catches from within the PAP-SO with other catches on the abyssal plain some 40-100 nm from the PAP-SO centre. The authors concluded that while the '*Amperima* Event', a major increase in the abundance of the small holothurian *Amperima rosea*, was evident across the abyssal plain generally, some variation in spatial ecology was detectable. More recent photographic surveys have revealed that 'trawl marks', potentially of significant age, remain visible and may act as detritus and litter 'traps', acting as sinks for material laterally advecting at the seabed.

Compared to the trawl surveys, more recently, large-scale seabed photography has become an important tool in the study of benthic ecology at the PAP-SO, including investigations of various abyssal hills in the area (Durden et al., 2015, 2020), with our understanding of the spatial ecology greatly enhanced by seabed photography from the autonomous underwater vehicle *Autosub6000* (Morris et al., 2016). Prior data stem particularly from the NERC-funded Autonomous Ecological Surveying of the Abyss (AESAs) project (NE/H021787/1) undertaken in 2012 using *Autosub6000* from RRS *Discovery* Cruise 377/8 (Ruhl, 2013), as detailed in Morris et al. (2014). Other photographic

surveys, using towed camera systems (WASP and HyBIS), were carried out in 2011 (NERC Oceans 2025) and 2018/19/21 (NERC CLASS), as tabulated below (Table 3.1).

Table 3.1 Imagery datasets from the PAP-SO

Cruise	Report	Vehicle	Abyssal plain	Abyssal hill
RRS <i>James Cook</i> Cruise 62, 2011	Ruhl (2012)	WASP	✓	✓
RRS <i>Discovery</i> Cruise 377/8, 2012	Ruhl (2013)	Autosub6000	✓	✓
RRS <i>James Cook</i> Cruise 165, 2018	Ruhl (2019)	HyBIS	✓	✓
RRS <i>Discovery</i> Cruise 103, 2019	Hartman (2019)	HyBIS	✓	
RRS <i>Discovery</i> Cruise 130, 2021	Hartman (2021)	HyBIS	✓	✓

For logistics reasons, however, the most recent visit to the PAP-SO, RRS *James Cook* cruise 231 (Hartman, 2022), was unable to undertake any seabed photography. Consequently, the primary objective for the present cruise, while at the PAP-SO, was to undertake a large-scale seabed photographic survey using *Autosub5*, the successor vehicle to *Autosub6000*.

3.3. New technologies: RoCSI (*Susan Evans*)

To understand the natural state of marine ecosystems, there is a need to characterise biological baselines in remote environments that are often challenging to sample. The use of emerging technologies to facilitate genetic observations has great potential to improve baseline data, especially in environments like the deep sea. Environmental DNA (eDNA) analysis has the potential to characterise biological communities with high sensitivity and species-level accuracy without disturbing organisms in the environment, by sequencing DNA signatures from sloughed cells, scales, faeces or other material left behind (Wood et al., 2020). During JC237 cruise, our work aimed to demonstrate simultaneous biological sampling using the high-resolution autonomous sampler, the Robotic Cartridge Sampling Instrument (RoCSI) recently developed at National Oceanography Centre, UK in the nose of the new *Autosub5* (Fig. 3.1), together with image and multibeam surveys at different altitudes from the seabed.

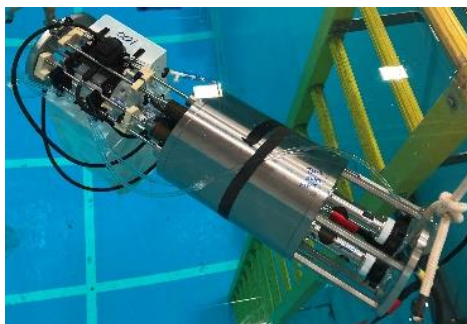

Figure 3.1 RoCSI in the NOC test tank (photo credit: Susan Evans, NOC)

The RoCSI is designed to filter and preserve predefined volumes of water in-situ collecting genetic material such as eDNA on a 0.22 µm filter. As well demonstrating the ability of RoCSI to work autonomously at depth, our work during the cruise also included the collection of samples for eDNA analysis using ROV pushcores, megacores, traditional CTD-rosette deployments and also water collected during ROV dives to validate and compare to the autonomously collected samples.

4. OBJECTIVES

Based on the over-arching research aims of the CLASS and iAtlantic projects, as described above, and on the existing body of research for the Whittard Canyon system and the Porcupine Abyssal Plain at the time of sailing, the objectives and specific tasks for the expedition were listed as follows (with, where relevant, the level of priority).

4.1. Whittard Canyon & The Canyons MCZ

- Revisit key habitats/locations from previous cruises to monitor change (geological, biological):
 - (1)Repeat photogrammetry of CWC reefs in Explorer Canyon (Price, 2021)
 - (1)Repeat vertical mapping of the 'Acesta wall' (Robert et al., 2017)
 - (1)Repeat vertical mapping of the 'coral wall' (Huvenne et al., 2011)
 - (1)Repeat AUV mapping of Explorer Canyon (Price, 2021)
 - (1)Repeat AUV mapping of the 'Acesta branch' (sideways-looking?) (Robert et al., 2017)
 - (1)Repeat AUV mapping of the 'coral branch' (Eastern branch of Whittard Canyon; Robert et al., 2017)
 - (1)Repeat photogrammetry of Acesta wall (Robert et al., 2017)
 - (1)Repeat photogrammetry of coral wall (Robert et al., 2017)
 - (1)Repeat AUV mapping of sandwave area E&W (Lo Iacono et al., 2020)
- Improve our understanding of species distribution within the canyon system, and of human impacts
 - (1)Groundtruth species distribution models from Robert et al. (2015), Pearman et al., (2020) and Price (2021)
 - (2)Video surveying for evidence gathering in Canyons MCZ (including Dangeard Canyon)
 - (2)Identification of litter on ROV video surveys
- Investigate sediment transport dynamics in Whittard Canyon (including internal waves, transport of organic carbon and microplastics)
 - (1)Coring transect close to the location of the CLASS mooring
 - (1)Coring up/down-canyon of a high deposition area in E branch, identified by colleagues from NIOZ (Furu Mienis, pers. comm.)
 - (1)Coring on interfluves to investigate organic carbon content of the trawled sediments
 - (2)Coring transect deeper in the canyon (E branch, ~3000m)
 - (1)Photography/video 'bowl-shaped depressions on sandwave fields
 - (1)SAPS close to seabed above coring locations to identify organic carbon content and composition close to seabed, and to compare with content preserved in the sediment record
 - (1)SAPS close to seabed above/next to major communities (e.g. coral wall, Acesta wall) to identify OC content and composition that may act as food source for these communities
 - (2)If there is time: AUV map and ROV groundtruth around the high deposition area in the Eastern branch
 - (1)Survey the canyon with Deepglider deployed during DY152 to identify internal wave characteristics and water column structure in the Eastern branch and tributaries
 - (1)CTD casts needed to calibrate the Deepglider
 - (2)13 hour yoyo CTD cast to capture internal tide (including with LADCP)
 - (2)AUV mapping of canyon branch with standing internal wave as described by Hall et al. (2017)
 - (2)ROV groundtruthing of canyon branch with standing internal wave

- (1) ADCP measurements during all AUV missions at >15m altitude
- Monitor status of the coral minimounds in the Explorer and Dangeard interfluves (as described by Stewart et al. (2014) and Davies et al. (2014)):
 - (1) Gather AUV photography on minimounds to check for live coral
 - (1) Install colonisation experiments on minimounds
 - (1) Repeat AUV mapping of minimounds to check for trawlmark situation (compare with Pearman (2020))
 - (2) Expand bathymetric mapping to fill SE corner of MCZ
- Collect eDNA samples
 - (1) Collect RoCSI eDNA samples alongside habitat mapping data (AUV MBES, photography)
 - (2) Collect eDNA samples from the water column using the shipboard CTD rosette or ROV Niskins
 - (2) Collect eDNA samples in the sediment
 - (1) Run the continuous plankton recorder in parallel with the benchtop RoCSI on long transits

4.2. Porcupine Abyssal Plain

- undertake a large-scale seabed photographic survey using *Autosub5*, to extend the time-series of benthic ecological data derived from photographic assessments. Beyond a simple extension of the time-series, the large-scale *Autosub5* seabed photographic survey aimed to address two inter-related sub-objectives:
 - Within the currently defined PAP-SO area is there any evidence that scientific trawling has influenced the ecology of megabenthic populations? To investigate this potential effect on local ecology, the primary photographic survey aimed to encompass three distinct areas having potentially different trawling histories: (a) “PAP-Central”, the routine coring and seabed photography site for the PAP-SO time-series, having only been subject to scientific trawling in the early decades of the time-series; (b) “PAP-Trawl”, a site within the area routinely trawled throughout the time-series; and (c) “PAP-Mooring”, a site on the extreme periphery of the routinely trawled area, adjacent to the area currently reserved for mooring operations, expected to have been seldom if ever impacted by scientific trawling.
 - survey an area to the south of the current “PAP-Central” site that has not previously been used for PAP-SO operations. A preliminary assessment of the bathymetry and seabed environment in this prospective new area was carried out during RRS *Discovery* Cruise 130 (Hartman, 2021)
- During the AUV missions, undertake ROV *Isis* dives with the objectives to:
 - Carry out visual observations (documented with video and still photography) of the seafloor environment, in particular to note aspects of natural history, and local seafloor topography, in particular any occurrence of trawl marks and any occurrence of seafloor disturbance associated with gravity flows from abyssal hills.
 - Carry out targeted sampling of biological specimens with the general aim of improving the taxonomy, visual identification, and natural history of the resident megabenthos.
 - Carry out targeted seabed coring within and adjacent to distinct trawl marks to enable additional investigation of their potential to act as organic matter traps and influence local ecology.

4.3. Additional aims and objectives to support collaborative work with other institutes and research groups

- On request from Jeroen Ingels, Florida State University Coastal and Marine Lab: obtain additional ROV pushcores for the further study of free-living nematodes associated with symbiotic bacteria in the Whittard Canyon
- On request from the NOC MARS team: recover Bathysnap mooring deployed in the Whittard Channel during DY152, assess performance on new Bathysnap IV camera system
- On request from Rachael Jeffreys, University of Liverpool: obtain biological samples at PAP for the study of desaturate genes in deep-sea fauna
- On request from Gavin Foster, University of Southampton: collect live *Desmophyllum pertusum* colonies to study the biomineralisation of cold-water corals with micro-CT scanning.

5. NARRATIVE

Tuesday 2 August 2022 – JD 214

Sunny with partial cloud cover. Warm.

Science party and technicians join RRS James Cook from 10 am. Lateral Flow testing at gangplank, PCR testing immediately on board. Mobilisation of large equipment throughout the day, lifting of science gear on board in the evening.

Ship familiarisation, initial science meeting in the afternoon, unpacking of some boxes in the evening.

Wednesday 3 August 2022 – JD 215

Partly cloudy, warm.

Mobilisation continues, unpacking of science material and setting up.

Science meeting in afternoon.

Thursday 4 August 2022 – JD 216

Partly cloudy, warm.

Load testing of AUV and ROV gantry, bunkering, further mobilisation of large equipment.

Sign on, safety briefing in the morning.

Science meeting in the afternoon.

Friday 5 August 2022 – JD217

Sunny, warm

Further unpacking of equipment, setting up of labs. Checking all materials are on board.

Science meeting in the afternoon.

Saturday 6 August 2022 – JD218

Sunny, warm, light easterly wind

At 09:00 BST the science team were introduced to the ROV Isis and the ROV control van. At 11:00 BST we slipped ropes and set sail towards the Whittard Canyon. Sailing was smooth with a calm sea and following easterly winds. Our designated MMO went on watch for the required period of time, and as no marine mammals were observed, we started up the EM122 and EM710 multibeam systems at 12:12 BST (11:12z). Once we were clear from the Solent traffic, at 14:03 BST (13:03z) we deployed the CPR through the A frame (**JC237-01-CPR01**), to provide calibration for the eDNA samples that Susan Evans and Nathan Hubot started to take with the benchtop RoCSI (using the 'non-tox' surface waters). From that point onwards, the science team went on watch. At 16:15 BST there was a safety drill. Transit to our first study site continued smoothly.

Sunday 7 August 2022 – JD219

Sunny, slight seas 2-3, NE wind force 3

Clocks went back one hour overnight to bring us to GMT. This will make logging much easier, and will avoid confusion between ship time and science recording time. The transit continued towards the outflow channel of Whittard Canyon, where we will have our first station.

Monday 8 August 2022 – JD220

Sunny, slight seas 2-3, NE wind force 3

Shortly after midnight (00:19z) the CPR was recovered on board (JC237-001-CPR01) as we were about to arrive on the first CTD station, at 4030 m water depth, 2 km north of the location where on the previous cruise a Bathysnap lander had been deployed (to be recovered on JC237 – see below). The CTD was deployed at 01:13z (**JC237-002-CTD01**), and brought back on deck by 04:48z. The frame carried the SAPS system, but no filtration was carried out, although the pump was tested successfully. The system also carried an upward and downward LADCP, and the sound velocity probe, so a correct sound velocity profile could be created for the USBL and multibeam systems.

With the CTD back on deck, the ship was repositioned closer to the Bathysnap. At that location, at 06:12z, the cable of the ROV was streamed, which took until about 11:12z. Ca. one hour before the cable was back on board, the Bathysnap was interrogated, and eventually the acoustic release was triggered at 10:18z (**DY152-BSNAP-TRIAL**). The lander was sighted at the surface at 11:37z and recovered on deck by 12:18z.

With the Bathysnap successfully recovered, we steamed to The Canyons MCZ for the deployment of Autosub5 (**JC237-003-A5M31**). We arrived on site at 15:27z, and the vehicle was deployed immediately (15:39z). It reached the start waypoint on the seabed at 16:30z. From that point onwards, we left the AUV to its mission, and we moved to the first megacoring location on the interfluvium south of Dangaard Canyon. This was reached at 17:16z and the core was deployed at 17:15z (**JC237-004-MGC01**). With only a water depth of 485 m, the core reached the seabed at 17:42z. A good pull-out was noted (2.6T), and the core came back on deck at 17:58z with 8 full tubes of stiff clay. A second core was attempted ca. 6nm further north, on the interfluvium south of Explorer Canyon, but this time the core failed (**JC237-005-MGC02**, on bottom at 20:05z). Because we had planned a multibeam survey to cover a data gap for JNCC on the south-eastern corner of the MCZ, we left the site and set off at 21:00z to start the survey.

Tuesday 9 August 2022 – JD221

Sunny, slight seas 2-3, NE wind force 3

The multibeam survey continued until 07:00z, at which point the ship moved to the next waypoint for the first ROV dive of the cruise. As the ROV was ready to come off deck, a signal was received from the AUV. The ship immediately diverted to the AUV location, and the Autosub5 was picked up, arriving on deck at 09:19z. Data analysis indicated that the mission abort was triggered by an 'under minimum altitude' alarm early into the photographic survey.

With the AUV back on board, the ship returned to the ROV station, and Isis was eventually deployed at 10:20z (**JC237-006-ROV382**). The ROV reached the seabed at 10:56z, for a short dive to deploy two coral settlement experiments on the canyon interfluvium. The dive was completed by 13:02z and the vehicle was back on deck by 14:04z.

By that time, the Autosub had been reprogrammed for a short mission to complete the photo survey over the coral minimounds. The ship repositioned to a new AUV deployment location, and the vehicle was in the water by 14:45z (**JC237-007-A5M32**). We followed the AUV for a short while, and once we were confident that the system was performing well, the ship repositioned again for a short CTD dip (**JC237-008-CTD02**). The CTD was in the water at 16:02z and back on deck at 16:32z. No further operations were planned while the AUV was in the water, hence the ship followed a slow course along the centre line of the AUV survey track to monitor the vehicle. All went well until the AUV started surveying the coral minimounds: once again the small mounds turned out to be too steep for the Autosub and the mission was aborted. The vehicle was picked up and brought on board for 19:38z.

In the meantime the ROV was turned around for its next dive, hence with a short ship move we were on station for **JC237-009-ROV383** in Explorer Canyon. The ROV was in the water at 21:55z and at the seabed at 23:15z.

Wednesday 10 August 2022 – JD222

Sunny, slight seas 2-3, NE wind force 3

The ROV dive finished at 10:27z and the vehicle was on board for 11:23z. The ship went on a short transit to the sandwave field at the head of the Eastern Branch, where the AUV was deployed at 13:37z (**JC237-010-A5M33**). Once the AUV survey had started, we returned to the last megacore station for a second coring attempt at a slightly changed location (**JC237-011-MGC03**). The core was deployed at 16:17z and back on deck by 17:06z, and this time it was successful.

The next operation was another ROV dive, and this time Isis was equipped with the rock drill (**JC237-012-ROV384**). The ROV was in the water by 19:07z, and the dive continued throughout the night.

Throughout the day, the glider was struggling to carry out the VM2 station at ~1000m water depth in top of Eastern Branch. Hence decision was taken to give up on VM2 and to start an along-canyon profile to greater depth.

Thursday 11 August 2022 – JD223

Sunny, slight seas 2-3, NE wind force 4

The ROV dive continued until 08:06z, and the ROV was on deck for 09:10z. By then it was time to transit to the AUV M33 site to pick up the Autosub. We arrived at 11:03z, but the AUV was not yet at the surface, so we waited. Shortly after, the vehicle aborted its mission, came up to surface and sent an email via Iridium. Its position was ca. 3 miles away. The ship was repositioned, and the AUV was recovered at 13:25z.

From there we went on a short transit to the CTD site at the top of Eastern Branch (**JC237-013-CTD03**). This was the location 'VM2' of the glider, which it had struggled with (couldn't stay in the canyon), hence the aim of the CTD was to compensate for the lack of glider profiles in this location. The CTD was deployed at 14:54z, and came back on deck by 16:04z. A very high turbidity was measured at the seabed.

From the CTD station, the ship repositioned to the next ROV site (**JC237-014-ROV385**). The ship was on site at 17:00z, but ROV pre-dive checks were still ongoing, so we sat on site until ROV was ready to dive. The vehicle was in the water at 18:31z. On the descent, from ca. 1000m depth, the water became highly turbid, severely restricting visibility and limiting the ROV operations. Because by then the senior ROV tech was out of hours, the vehicle could not be recovered, so we developed an alternative dive plan, trying to stay shallower where visibility was slightly better.

Friday 12 August 2022 – JD224

Hazy sunshine, smooth seas 1-2, N wind force 3

The ROV dive continued through the night, but the water was still very murky and in some places a strong current limited the operations. It seems that we were visiting this site (a repeat of the 2009 'coral wall' JC036 Isis Dive 116) on the wrong phase of the tide, so the decision was made to come back later in the cruise, during neap tide.

The ROV was on deck by 09:40z, and the ship was repositioned for a CTD + SAPS in the canyon, more or less at the same location (**JC237-015-CTD04**, in water: 10:34z, back on deck at 13:05z). A USBL beacon on the CTD frame was used to guide the operation to ca. 50 m off the coral wall. The SAPS pumped for one hour, and the filter was well covered with particulate matter.

The next operation was another deployment of the AUV, in Explorer Canyon, for a combined multibeam and low-res sidescan sonar survey, and repeat of Autosub6000 M98, undertaken on JC125. The AUV was still without the RoCSI, as it still had issues with the motor (**JC237-016-A5M34**). The AUV was deployed at 15:34z, and was monitored until it reached the seabed. The ship was free to sail to the next station by ca. 17:00z. Isis was deployed at 18:39z, again in the Eastern branch, but this time slightly deeper, in an attempt to repeat JC125 Isis Dive249 (**JC237-017-ROV386**). Unfortunately, again a massive current was experienced at the seabed, which meant it took a long time to get to seabed, and to start the transect. Several waypoints could not be reached, and adaptations to the start of the dive plan had to be made.

Saturday 13 August 2022 – JD225

Hazy sunshine, calm seas 1-2, N wind force 3

The ROV dive continued, finally reached the seabed and managed to run the dive as planned. The ROV was on deck by 10:30. As ROV came to surface, we received a message from Autosub that it had also surfaced. As soon as the ROV was on board (10:40z), we went to pick up the Autosub. A smooth recovery brought her on board by 12:05. MBES and SScs and SBP data were successfully collected, although there was an issue with a reset of the time in one of the systems.

This finished our work in the Explorer Canyon, so we set off to the Acesta Wall for an ROV dive. We arrived at 15:20z, and were ready to deploy the ROV (**JC237-018-ROV387**), but when lifting the ROV outboard, it became clear that one of the thrusters failed. The ROV was brought back on board and connectors were checked, but a second attempt also failed. The vehicle was brought on board again and a temporary fix was applied so it could be used for the dive (with only one vertical thruster). Eventually the ROV was in the water at 19:25z.

Sunday 14 August 2022 – JD226

Hazy sunshine, calm seas 1, N wind force 3

The ROV dive continued as planned until 09:30z, and the vehicle was on board by 10:28z. The ship repositioned to the AUV start position, and Autosub was launched for **JC237-019-M35** across the Acesta wall by 11:11z. After a long debate we decided to go for a reconnaissance mission first, to confirm the exact position of the canyon walls. This will then enable planning of a more detailed mission where we will map those vertical walls.

With the AUV in the water and navigating well to the seabed, the ship set off to the next canyon branch for some gravity coring. Two coring sites were chosen, one in the thalweg and one on the first terrace, of a canyon branch with a very flat bottom, to test if this morphology is caused by sediment infill or by the presence of a very resistant layer. The first core (**JC237-020-GC01**) was in the water at 12:38z, on the bottom at 13:04z and back on deck at 13:31z. It had very little pull-out, but did bring a small sample of sands overlying a stiff mud with mixed gravel. The second core (**JC237-021-GC02**, in water at 14:11z, back on deck at 15:04z) had an equally small pull-out, but again brought a short section of sandy core overlying a stiff mud.

From this, we moved to the deeper parts of the Acesta branch where we deployed Isis for her usual overnight dive (**JC237-022-ROV388**). The ROV was in the water by 16:27z. Just as she reached the seabed at 18:04z, a message came in from Autosub that the AUV was on the surface: it had aborted its mission. It was decided to send the AUV a command to come closer to the ship, while continuing the ROV dive. The dive targeted a knickpoint in the Acesta branch of Whittard Canyon, with some vertical walls with coral and brachiopods. Spectacular footage but challenging ROV flying conditions.

Monday 15 August 2022 – JD227

Sunny with partial cloud and occasional showers, sea state picking up 2-3, freshening winds 4-?

The ROV dive continued safely while Autosub continued to circle close to the ship. Isis was brought on board before breakfast (07:20z), and Autosub came on board by 08:42z. We then moved back to the Acesta wall for a CTD & SAPS (**JC237-023-CTD05**). The SAPS pumped for 1 h at 650m water depth. It was on deck by 11:53z, at which point we set off to the next gravity core site in the Eastern Branch. We arrived at the site by 14:22z, but before deploying the core, a series of tests were carried out on the heave compensation system of the starboard winch system (CTD). This continued till 15:45z, after which we could start gravity coring. The aim was to find the extent of a 'depocentre' in the Eastern branch, discovered by our colleagues from NIOZ. The first core (**JC237-024-GC03**), up-canyon of their high sedimentation rate core came back empty (17:22z). The second one (**JC237-025-GC04**), down-canyon of the Dutch coring site had gone in (18:55z), but lost the sediment because the core catcher sheared off. Hence we had another attempt at the same location (**JC237-025-GC05**), and this core did bring 0.7m of stiff mud (20:54z). Not exactly the 9 m recovery of our colleagues from NIOZ, though.

At this point the weather started to pick up, so we stopped over-the-side operations and started a multibeam survey, to extend multibeam coverage from previous cruises. The chosen area this time was an interfluvium between Explorer Canyon and one of the tributaries of the Eastern branch.

Tuesday 16 August 2022 – JD228

Overcast with regular showers, sea state moderate to rough, 4-5, N wind force 7-8.

Multibeam surveying continued through the night, but by 08:30z it became too difficult to keep the ship on course, and the data quality became so poor that we decided to stop work for several hours. The ship turned into the wind (N) and very slowly moved northwards. The situation did not improve until well into the evening, but by ca 20:30z it was safe enough to turn the ship around and start travelling back.

Wednesday 17 August 2022 – JD229

Overcast with showers, sea state moderate 4, wind force

As we had travelled well outside the study area for which we had dipclear, we only switched on recording of our acoustic systems at 00:55z. Once back in our study area, we acquired more MBES and SBP data to add to our general map of Whittard Canyon.

By 08:35z the ship was positioned at the next Gravity Coring site (**JC237-027-GC06**), the actual site of the NIOZ high sedimentation piston core. While the core was going down, we decided to move the ship 50m to the west to avoid having the core exactly on what looked like a small cliff at the edge of the canyon thalweg (09:41z). Recovery this time was very good, with the entire 3 m core full of sediment and the core weight having gone into the mud, but there didn't seem to be any mud on the inside of the core weight so chances are that not too much of the top sediment was lost.

With the weather continuously improving, we set off back to the Acesta wall, in order to try to map the area again with the Autosub (**JC237-028-A5M36**, deployed 14:04z). The mission had to be split into two sections, because the close following of the wall required too many waypoints. The plan was to first map the vertical walls, while following the AUV with the ship and updating its position through the USBL. The less onerous part of the mission was then scheduled next, to give us the time to deploy the ROV. Unfortunately, the AUV aborted the mission after 1h, apparently because the minimum altitude had been exceeded. We recovered the vehicle on deck (16:05z), but data analysis showed that this probably was a false return on the ADCP. The AUV was then turned around quickly, and re-deployed (17:21z) for the less difficult part of the mission (**JC237-029-A5M37**), with the idea to map the walls the next day.

Once this mission was underway, the ship set sail for the next ROV location, ca. 6 nm away. Just as the ROV was about to launch, there was a message from the Autosub that it had surfaced again. This time it had not aborted the dive, but came to the surface due to a mission time-out. It was decided to continue the ROV deployment (**JC237-030-ROV389**), while in the meantime sending the AUV new missions via Iridium. Isis was in the water by 19:20z and carried out the dive investigating a knickpoint in a parallel canyon tributary to the Acesta branch.

Thursday 18 August 2022 – JD230

Overcast with low-hanging clouds, sea state slight 1-2, W wind force 4.

The ROV dive progressed well through the night, and finished at 08:45z. Isis was on deck by 09:23z.

We made our way back to the Acesta wall, where Autosub was waiting to be picked up. In the end she had carried out three 'splits' of the main mission and still had 44% of battery left. She was brought on board by 10:49z, and re-charged, reprogrammed and prepared for another try of mapping the vertical walls in the Acesta branch (**JC238-031-A5M38**, in water by 13:33z). We kept following her on the USBL,

and initially the mission went well, but unfortunately more or less halfway she aborted the mission again and came to the surface. She was brought on deck by 16:13z, and we set off to the Eastern branch once more to take more cores in the depocentre.

We arrived on site by 19:01z and started with a gravity core in the thalweg (**JC237-032-GC07**). Despite being only ~200m away from the previous gravity core that was overfilled with mud, this core did not bring back anything more than a scrape of very stiff clay. We then re-positioned back to the site of GC06 and took a Megacore (**JC237-033-MGC04**, 22:03z), in order to obtain the sediment-water interface. This core was successful with 6 tubes filled by muddy sediment.

With worsening weather conditions predicted, we then started a multibeam survey overnight.

Friday 19 August 2022 – JD231

Sunny, slight to moderate seas with a long swell 3-4, light N winds force 3-4

We broke off the multibeam survey to travel to the next sampling location: the knickpoint in the Explorer Canyon. There we set up at 06:10z for a 13-hour yoyo CTD (**JC237-034-CTD05_13**). Throughout the cast, the conditions worsened, and occasionally 5-7m swells were recorded. This slowed down the CTD casts, but we managed to continue and had 8 casts completed by the end of the 13 hours (18:59z).

By that time the swell had calmed down enough to deploy the ROV, and **JC237-035-ROV390** went in at the knickpoint as well at 20:06z

Saturday 20 August 2022 – JD232

Sunny, slight seas 2-3, W winds force 4

ROV Dive 390 continued with spectacular views of sheer vertical walls hosting coral-dominated and sponge-dominated assemblages. The vehicle was back on deck by 11:20z, and we moved back to the 'depocentre' coring location to take another gravity core slightly higher on the canyon flanks, to determine how high above the thalweg the mud is accumulating there (**JC237-036-GC08**). The core was successful (13:16z), and following that, we moved over to the interfluvial between Explorer and Dangaard Canyons to carry out another AUV MBES-SScS-photo survey, this time with the RoCSI eDNA sampler in action (**JC237-037-A5M39**). The AUV was launched by 15:57z, and 40 min later we travelled back to the Eastern Branch for another attempt at an ROV dive in the area of the coral wall (**JC237-038-ROV391**). We arrived at 18:50z and the vehicle was deployed by 19:05z. The deployment was made more difficult by a large swell and increasing winds. In general, the dive turned out to be difficult again: very low visibility and strong currents meant we could not carry out the dive plan, and could not image the coral wall.

Sunday 21 August 2022 – JD233

Fog and low cloud, slight seas 2-3 with still a long swell, W winds force 3-4

The ROV dive continued until 07:38z, but had to be redirected to shallower, and more sedimented areas. On the ascent, at 08:18z, the vehicle lost power, and it had to be recovered as a 'dead vehicle'.

It came on board by 09:01z. In the meantime, the AUV once again aborted its mission due to an 'under min alt' warning on the photo transect, so this was picked up next (on board by 11:40z). To give the ROV time for reparation, we decided to carry out a CTD+SAPS (**JC237-039-CTD14**) at the location of the depocentre, to check for turbidity (13:37z – 16:29z). That turned out to be less than expected.

Next operation was a triangulation of the Whittard mooring, to confirm its current location, and to reduce the risk of collision during the next planned AUV mission. The triangulation started at 17:22z and was completed at 17:44z. The mooring was still in the same place as where it had been deployed on the PAP cruise earlier in the year. Two more CTDs followed, to capture the dynamics in the Eastern Branch (**JC237-040-CTD15**, 18:27z – 19:50z, and **JC237-041-CTD16**, 20:52z–22:05z). They did show high turbidity at the seabed, so we decided not to plan an ROV dive in these areas. We finished the day with a gravity core (**JC237-042-GC09**) further down in the Eastern branch.

Monday 22 August 2022 – JD234

Fog and low cloud, slight seas 3, SW wind 4-5

After the gravity core came on deck (at 01:33z), we started a multibeam survey that lasted until 08:55z, the planned time to put the Autosub in the water for the mapping mission of the coral wall section of the Eastern canyon branch (**JC237-043-A5M40**). The vehicle was in the water by 09:01z and started to dive at 09:11z. We followed the AUV for the first 2 hours, to monitor her behaviour over the most difficult parts of the terrain. Shortly after 12:00z we then moved to the next coring location, on a terrace right in the bend of the Eastern branch (**JC237-044-GC10**). The gravity core was deployed at 13:35z and recovered by 15:03z. Unfortunately, once again it contained very little sample.

With the core on board and the AUV still carrying out its mission, we set off to the Explorer Canyon knickpoint for an ROV dive with the rockdrill. We were on station shortly after 16:00z, but as the ROV was powered up, a groundfault on one of the thrusters was identified, and the ROV had to be brought back on deck. The repair appeared to need several hours, so we moved the vessel slightly and started a CTD + SAPS (**JC237-045-CTD17**) at 18:34z. In meantime ROV was repaired, a thruster connector was replaced. The CTD came on deck by 21:18z, and we repositioned the ship, back to the ROV location (**JC237-046-ROV392**), where the dive started at 21:33. The first rock drill of the dive was successful, but for the second one it was more difficult to find landing place: currents kept sweeping the ROV away. Unfortunately, the second core also got stuck in the barrel. The dive continued with biological sampling and rock sampling.

Tuesday 23 August 2022 – JD235

Fog and low cloud, rain, slight seas 3, SW wind 4

The ROV came on deck by 10:02z. Just at the end of the ascent, we received a message from the AUV that it was at the surface, with the mission completed, but that the batteries had run low so it dropped its weight. Hence, as soon as the ROV was on deck, we set sail to pick up the AUV. The vehicle was spotted at 11:50z, grappled by 12:22z and on deck by 12:33z. After a slight repositioning, we then carried out a CTD halfway between the depocentre and coral wall to test for turbidity (**JC237-047-CTD18**, 13:44z – 15:15z).

From there, we travelled back to the Acesta wall for an ROV dive with forward multibeam survey (**JC237-048-ROV393**). The ROV was in the water by 18:40z. The forward MBES survey carried on through the night.

Wednesday 24 August 2022 – JD236

Rainy start, clearing up later in the day. Calm seas 2, N wind force 4

The ROV came on deck by 09:45z, and we travelled back to the MCZ for an AUV photo & RoCSI mission over the Explorer interfluve (**JC237-049-A5M41**). The AUV was deployed at 13:32z, and followed for a short while. All was found to be good, so from there, we went on transit to the next ROV deployment site in the Dangaard Canyon. As we arrived there, we received a message that the AUV was at the surface. Hence, we turned the ship around and went back to the interfluve to pick up the Autosub first.

The recovery went OK (17:19z), so we went straight back to ROV dive site on flank of Dangaard Canyon (**JC237-050-ROV394**). The ROV was in water by 18:28z.

Thursday 25 August 2022 – JD237

Partly cloudy, slight to moderate seas 3, N wind force 4

The ROV was brought back on deck by 08:41z, and the ship set off on transit to PAP. The CPR was deployed at 08:49z for the duration of the transit (**JC237-051-CPR02**).

The transit continued for the rest of the day. We were followed by dolphins for part of it, to everybody's delight. Ship's speed was lower than planned, as we were going against swell and wind, but there were plenty of fishing vessels heading the same way.

Friday 26 August 2022 – JD238

Overcast, calm seas 2, N wind force 4

By the next morning, the weather conditions had improved enough that the transit speed could be increased to 10kn. We continued the CPR tow until 12:03z. Once arrived on the first station, we first deployed the CTD (**JC237-052-CTD19**) down to 4000m to obtain a sound velocity profile. The system was back on deck by 15:12z.

The ship then repositioned to the first PAP AUV deployment site (**JC237-053-A5M42**) and the AUV was deployed at 15:37z. We followed the AUV on the USBL to the seabed, and by 18:30z moved to the first PAP ROV site 3km away (**JC237-054-ROV395**). The ROV was in the water by 19:26z, diving to 4840m, where it arrived at 22:25. The dive progressed well through the night, and had as main aim to collect specimens for taxonomic ID. To assist with this, we set up a Teams call with 3 colleagues back in Southampton (Andy Gates, Tammy Horton and Jen Durden), and managed to stream ROV video of a sufficient quality back to base. The colleague researchers could see one camera (we could choose between the 3 HD cameras) and communicate via a Teams chat.

Saturday 27 August 2022 – JD239

Largely overcast, calm seas with a moderate swell 2-3, NW wind force 4-5.

ROV left seabed at 09:20z, and came on deck by 12:54z. AUV had not been seen or heard by then, but soon after ROV recovery, USBL system picked up the signal. The vehicle was at ~1500m water depth and was coming up under her own power. Recovery went smooth until the aft line parted with the line on the winch, which required expert grappling from the deck crew to bring the line back on board. Eventually the AUV was recovered safe and well by 14:46z. Unfortunately, it appeared that the front electronics bottle had a short circuit at the very end of the mission, at the surface. It needed quite a bit of repair – basically a replacement of the bottle with the spare.

While the AUV team were completing this repair, we moved to the ROV site, and set up for the next dive (**JC237-055-ROV396**). The ROV team worked fast to turn the vehicle around, and at 17:17z the ROV was off the deck, but during the power-up a fault was noticed in the control system ('topside'), and the vehicle had to be brought back inboard. The problem was solved by 19:03z and the ROV was deployed successfully, this time over an abyssal hill north of the PAP central site. This dive was also streamed live to shore.

Sunday 28 August 2022 – JD240

Fair weather, sunny with light cloud. Calm seas with light swell 2, wind force 4

The ROV dive continued till 10:16z, and was extended by 90 mins because the AUV team needed more time to repair the electronics bottle. The vehicle was on deck by 13:14z, and we moved gradually towards the AUV deployment site (**JC237-056-A5M43**). The AUV was lifted overboard, but failed one of the pre-dive checks, so had to be brought back on board for a small tweak before being deployed fully at 15:57z.

Once the AUV was well on its way, we moved the vessel to the next ROV deployment site (**JC237-57-ROV397**), where she was deployed at 19:59z. Once again, the video was streamed live to shore via Teams.

Monday 29 August 2022 – JD241

Partly cloudy, calm seas 1-2, wind force 4

This morning, the ROV was recovered on deck by 11:27z, after which the ship moved over to pick up Autosub, although no sign of the AUV was found on the USBL. It turned out that the estimate of total dive time by the Autosub engineers was wrong. So we waited, and waited some more. Eventually vehicle was registered, the abort weight was dropped and AUV surfaced at 16:15z. She was grappled and picked up at 16:29z. This completed our work at the PAP-SO, and we set off on transit back to Whittard Canyon. Once again, the CPR was deployed along the way (**JC237-058-CPR03**, in the water at 16:34z)

Tuesday 30 August 2022 – JD242

Cloudy, increasing seas to moderate 4, E wind force 6

The transit continued, but the ship had to slow down as the weather deteriorated. We arrived back in the Whittard Canyon area, and recovered the CPR (17:15z). Unfortunately, upon arrival at the deeper Eastern Branch site, the ROV had developed a fault in the cable, and the conditions were not deemed good enough for ROV work. Hence we had to switch over to alternative work: gravity coring. In order to help choosing good coring sites, we first ran a few SBP lines in the Eastern Branch where the canyon is widening. Core was deployed at 19:05z, but at 19:38z ship received a MayDay call and the core was brought back on deck at speed (80m/min) to enable us to assist (19:53z).

We set off in a northerly direction, and shifted to a NE direction shortly after. The vessel in distress was the Cintharth a French trawler, but by the time we met up with her she already received assistance from sister vessel Maëlys-Charlie who had taken her on tow. The fishing vessel with 5 crew was taking in water. Soon also an Irish fishing vessel (Tiger 2) came to help, and they handed over a diesel pump. The RRS James Cook provided shelter for the fishing vessels, and assisted by helping with translation (thanks to Nathan Hubot) between the French and Irish crews, and between the French crew and the UK Coast Guard.

Wednesday 31 August 2022 – JD243

Cloudy, moderate seas 4-5, E wind force 6, reducing to 5 later in the day

Unfortunately, the crew of the Cintharth did not manage to make the pump work properly, while they also lost the generator, and by 03:00z they made the decision to abandon ship at first light. At 05:45z they launched a life raft, and were towed to the French fishing vessel Bigoudens de Kerflous which had also come to assist. By 06:05z the operation was successfully concluded, and the Kerflous and Maëlys-Charlie, with the Cintharth in tow, continued their passage to Guilvinec. We turned around to return to the research area, by now 44nm away.

We arrived back in the Whittard Canyon for a CTD at the coral wall by 10:30z (**JC237-06-CTD020**). The CTD + SAPS was deployed at 10:53z and the SAPS pumped for one hour. This gave us first of all an indication of the turbidity at the area, and secondly a mini-time-series of how this turbidity and the POM and eDNA evolved over the duration of the cruise, given that we took casts there at two points in time before (CTD04 and CTD15).

The CTD was back on board at 13:18z, and we moved to the interflue between Explorer Canyon and the Eastern Branch for a last AUV mission in order to obtain RoCSI samples together with habitat mapping data at different altitudes above the seabed (**JC237-061-A5M44**). The AUV was deployed at 15:13z and followed to the seabed. Once we were confident it had started its mission, we moved back to the coring location that we had to leave so much in a hurry the evening before, because the ROV was still under repair. The gravity core (**JC237-062-GC12**) was in the water at 18:15z, and reached the seabed at 19:17z. However, on the way up the winch was showing scrolling problems so recovery was slower than expected (on deck by 21:25z). The core was good, though, and it was decided to carry out a megacore at the same location (**JC237-063-MGC05**).

Thursday 1 September 2022 – JD244

Sunny, slight to moderate seas, 3-4, N wind, force 5

The megacore came on deck by 00:50z, and carried 7 successful cores. For the rest of the night we ran a multibeam survey, continuing to build our bathymetric map of the canyon. We ended the survey by

09:30z at the AUV rendez-vous point, but it turned out that the vehicle needed more time to finish the mission. It took two more hours until we had a signal on the USBL and could assess which point in the mission the AUV had reached. We left her to continue until past midday, at which point the mission was aborted, so we could recover her and steam to the glider recovery point. Autosub was on board at 13:09z, and we made our way to the glider rendez-vous (**DY152-DEEPGLIDER**). Unfortunately, in the meantime it transpired that the AUV flash had developed a fault (faulty cable), and no useable photographs were taken.

The glider was spotted immediately upon arrival, was successfully caught and brought on deck by 15:00z. Given the swift recovery, there was time for a quick calibration CTD (**JC237-063-CTD21**), which was deployed at 15:16z and back on deck at 17:08z. We then moved on to the deployment location for the ROV (**JC237-065-ROV398**). The ROV was in the water at 19:00z for a dive in the deeper parts of the Eastern branch (>3000m). This was a repeat of a dive from 2009 (JC010).

Friday 2 September 2022 – JD245

Sunny, calm seas 2, SW wind force 4-5

The ROV dive continued smoothly till 11:12z. We then moved back to the last AUV deployment site to repeat the photo + RoCSI part of the mission (**JC237-066-A5M45**). The AUV was in the water by 12:57z. We kept an eye on the vehicle for the whole mission, and the vehicle was back on deck by 17:40z. This time, photographs were collected

We then moved over to a last megacore site, slowing down the ship to 5kn for the last 3 nm so we could obtain a good SBP. Before core was deployed, the crew took 30 mins to test the heave compensation on the 2nd CTD winch. This did not work either (just like the 1st CTD winch which we had been using all cruise), so confirmation could be sent to shore that an engineer of the winch company would have to come out to the ship to fix the systems.

By 20:50z the megacore was then deployed for a final core (**JC237-067-MGC06**), not in the canyon but rather on a high between the lower E branch, Dangaard and Explorer Canyon, to sample the 'background' sedimentation in the area. The core was successful and came on deck at 22:13z.

We then set sail for Southampton, starting at 5kn to obtain more SBP data, but speeding up to full speed at 23.47z in order to avoid a large storm system developing on the Atlantic. The CPR (**JC237-068-CPR04**) was deployed at 23:42z.

Saturday 3 September 2022 – JD246

Overcast with showers, slight to moderate seas 3-4, S winds force 5 increasing during the day

The transit continued with the CPR sampling and RoCSI filtering from the non-toxic until 19:05z. The science party held a meeting at 15:00 to discuss the overall results, and to organise the final packing and sample shipping. Clocks were changed back to BST overnight.

Sunday 4 September 2022 – JD247

The transit continued smoothly, and the ship was docked by 16:55 BST (15:55z).

6. METHODS AND INITIAL RESULTS

6.1. Acoustic mapping & profiling (*Tim Le Bas, Catherine Wardell*)

6.1.1. Shipboard Multibeam Systems: EM122 and EM710 Bathymetry & Backscatter (*Catherine Wardell, Tim Le Bas*)

Multibeam data were collected with the shipboard Kongsberg EM170 and EM122 systems along all Transits, while a few dedicated multibeam surveys were also performed. For dedicated surveys, a speed of 6-8kn was used and lines were occasionally surveyed in only one direction, to account for weather and poor data. All other transits were carried out at full speed (~10kn). The system was kept in 'AUTO' mode with varying expected depths to account for the quickly varying canyon terrain. Depth forcing was also frequently used in areas where bottom tracking had difficulties. Swath width was adjusted between 60 and 70deg on either side to account for weather and terrain, with equidistant spacing. Sound velocity profiles (SVPs) were taken in the shallow region of Whittard Canyon, as well as the deeper channel, and employed for the remainder of the surveys. Additional sound velocity profiles are available from CTD, ROV and AUV dives if required.

Data processing was carried out in CARIS Hips & Sips v10.4. The shipboard data were added to the existing Whittard Canyon project, containing the 2009, 2015 and 2018 data, using UTM zone 29. The vessel file used was James_Cook_EM122.hvf, and had the following offsets (draft was already applied during acquisition):

Time Corr: 0.00
X (m): 0.00
Y (m): 0
Z (m): 0
Pitch (deg): -0.23
Roll (deg): -0.8
Yaw (deg): 0.00

The data were imported to Caris as .all files (Generic Simrad data) and checked for navigation and attitude. Tide was predicted using the software Polpred (National Oceanography Centre) (Fig. 6.1) and applied to the data before it was merged and a BASE surface of 50m grid size was generated. The smaller dedicated survey of the Canyons MCZ was processed at 20m. Data cleaning was carried out on the individual lines using the Subset Editor. The grids were exported as .tiff (Fig. 6.2).

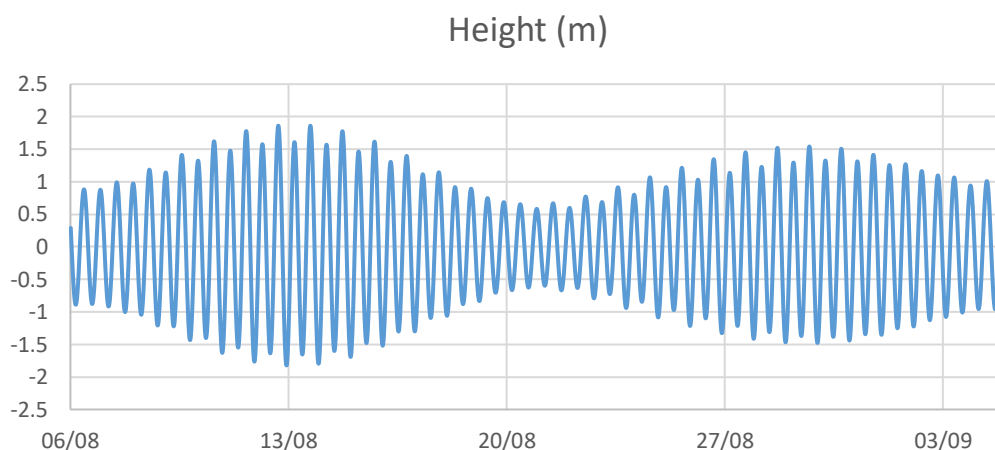

Fig. 6.1 Predicted tidal cycle during cruise – Whittard Canyon area

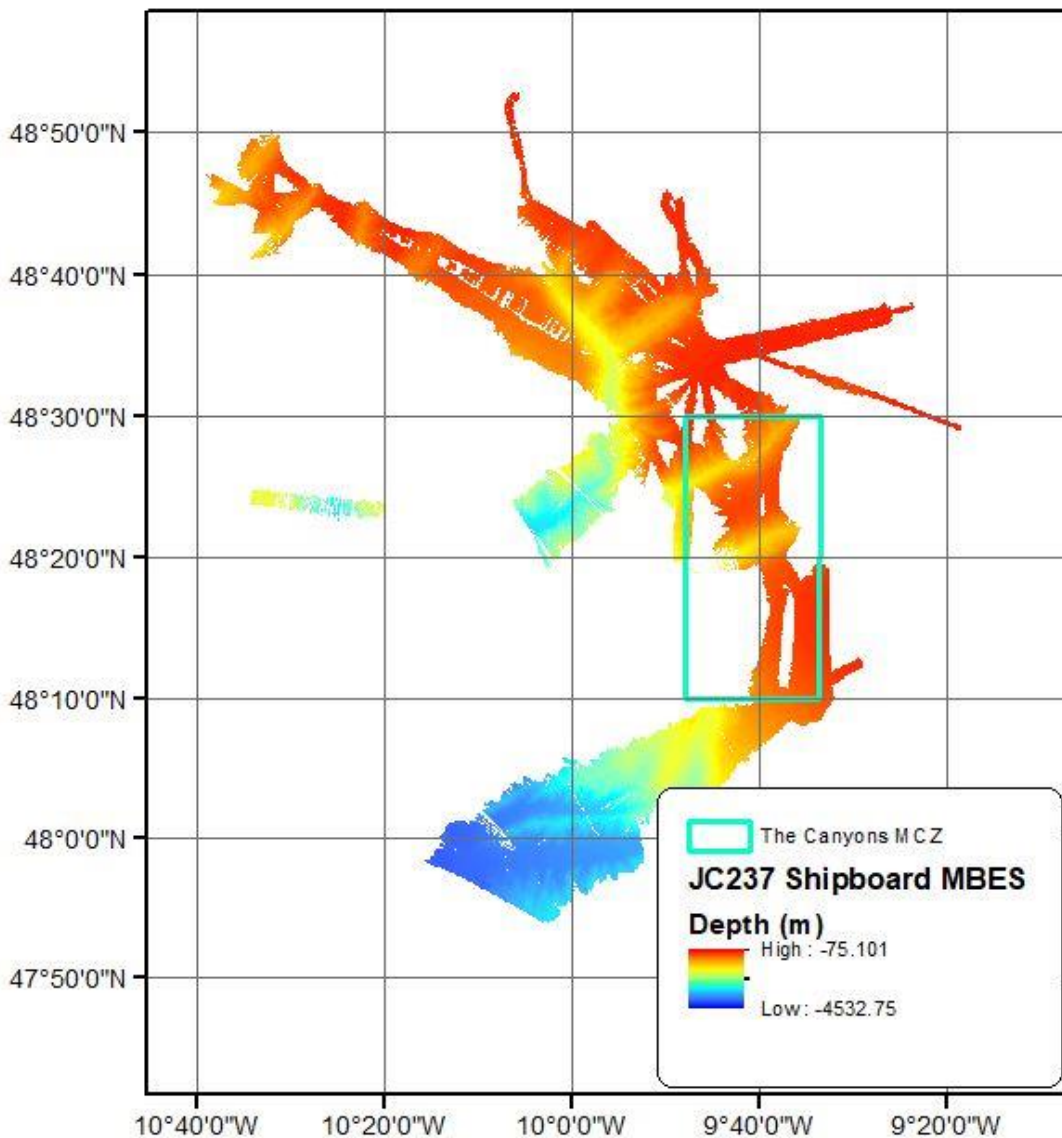

Fig. 6.2 Extent of the shipboard multibeam data collected during JC237 over the Whittard Canyon

6.1.2. Shipboard SBP System

The Kongsberg SBP120 system was switched on during longer transits, and for occasional dedicated surveys to help determine good coring locations. Default settings were used.

6.1.3. Autosub5 Multibeam Bathymetry & Backscatter (Tim Le Bas, Catherine Wardell)

The Autosub5 has a NORBIT Multibeam system which has a variety of operating frequencies in the range 200-700kHz, though the most used frequency is 400kHz. To obtain good coverage the line spacing of survey lines can be altered according to the altitude of the AUV above the seafloor (Table 6.1).

Table 6.1 AUV altitude, swath angle, and resulting range and suggested line spacing for the Norbit MBES and EdgeTech sidescan sonar systems installed on the Autosub5

	Altitude	Across Track Range	Line Spacing
Multibeam 140° 400kHz	75	206	300
Multibeam 140° 400kHz	50	133	200
Multibeam 140° 400kHz	15	40	75
Sidescan 410kHz	15	113	200
Sidescan 120kHz	50	500	750

When using the 400kHz bathymetry system it was noted that a certain amount of interference from the Edgetech sidescan sonar onboard the AUV is detrimental to the multibeam bathymetry data if used at the sidescan's higher frequency. Unfortunately given that this was the first science expedition for Autosub5, both systems had to be switched on at the start of the mission, if both needed to be used during the same mission.

The data output from the multibeam system is in the form of 3 files with the .log filetype:

e.g. NorbitBathyRawData_2022-08-20_12-46-42_file_1.log
 NorbitBathyRawData_SideScan_Snippet_2022-08-20_12-46-42_file_1.log
 NorbitBathyRawData_WaterColumn_2022-08-20_12-46-42_file_1.log

The sizes are generally large (in Gigabytes) in an approximate ratio of 1:5:15 respectively.

Given that this was the first expedition to use the new Autosub5 with the Norbit MBES system, the full processing flow is detailed below. The data processing comes in several stages:

Stage 1: Conversion from .log files to .wbm files

The NORBIT processing system must be installed first and then from the C:\Program Files (x86)\Norbit AS\WBMS directory, copy the file wbm_tool.exe to where the processing of the data is to take place (<data directory>).

Start a Command window (cmd) with administrator privilege and use the commands:

```
cd <data directory>
wbm_tool -c NorbitBathyRawData_2022-08-20_12-46-42_file_1.log
NorbitBathyRawData_SideScan_Snippet_2022-08-20_12-46-42_file_1.log
```

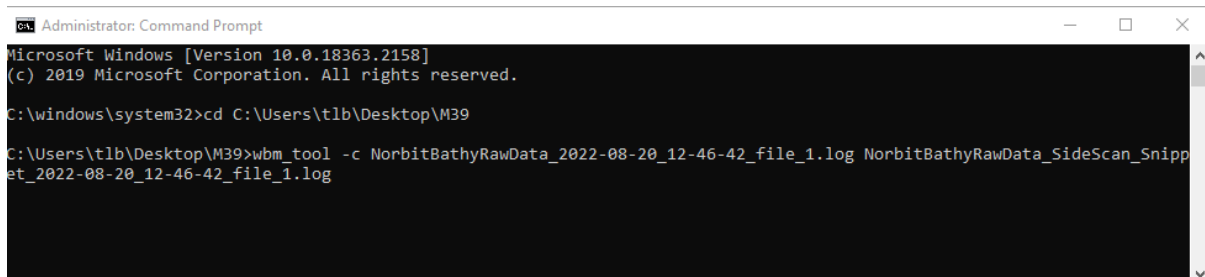

Fig. 6.3 Screenshot of the command window with the first processing command for the Norbit multibeam data

The running of the program will result in a lot of “dots” and may end with an error message but this can be ignored. The program will create in <data directory> a subdirectory with the name [0] and in it a file called sonarFile.wbm.

Stage 2: Conversion from wbm files to .s7k files

Using the WBMS GUI, the playback tab is used, selecting the wbm file. The blue slider can be used to see the wedge to find the beginning and end of good bathymetry data. Note the ping numbers of the beginning and end of (and times).

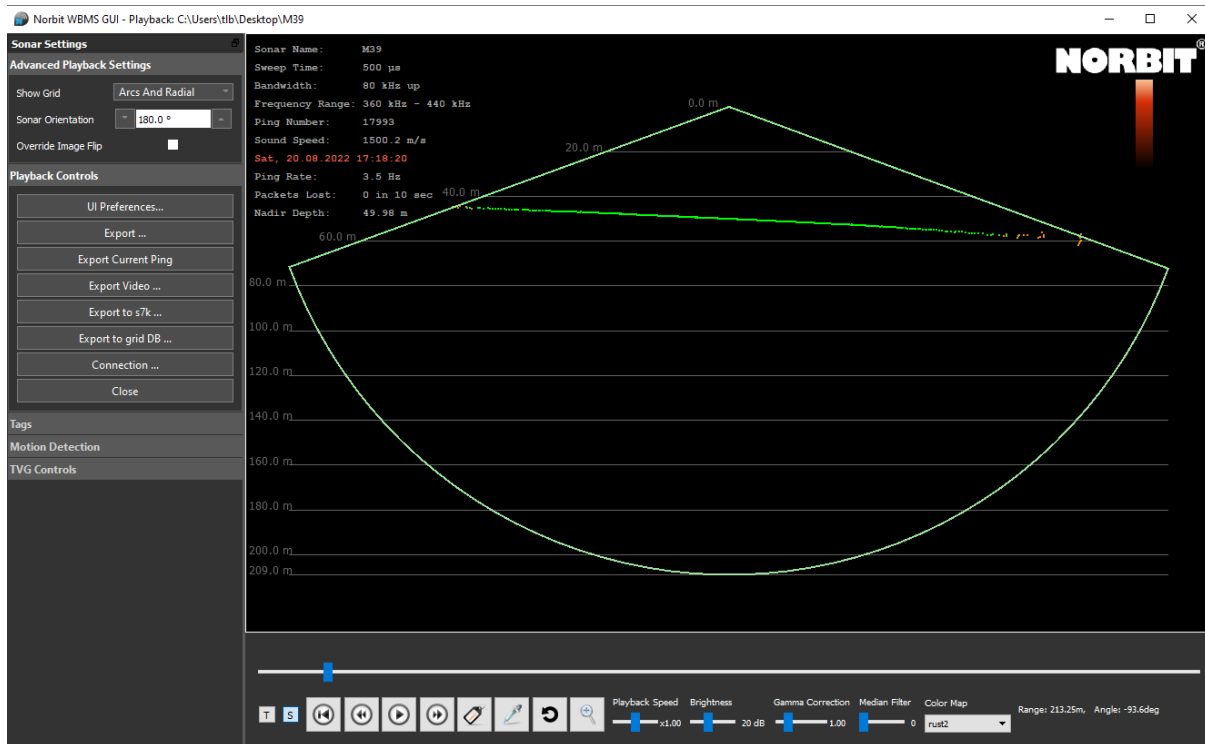

Fig. 6.4 Screenshot of the WBMS GUI illustrating the multibeam ping data

Use the Export to s7k... button to export to a s7k file. It is recommended that several s7k files are created, cutting the wbm file into approximately 10000 ping chunks, or if possible separate survey lines (using a time and ping number combination).

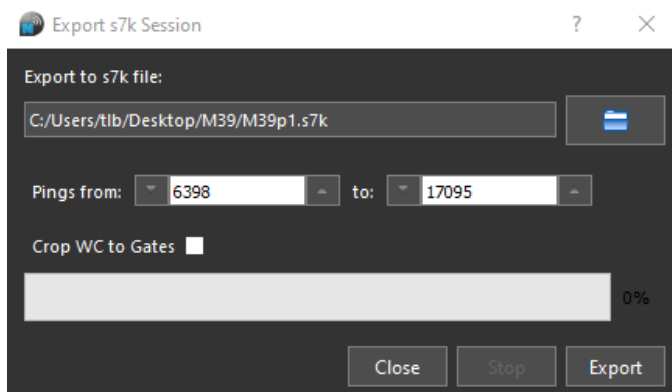

Fig. 6.5 Example of settings for the export of the .s7k files

Stage 3: Navigation file creation

The Norbit files unfortunately did not yet have imbedded navigation data and thus the data had to be added separately. The AUV team created navigation files called NorbitNav.csv

It has been found that the navigation files should have 0.1 second accuracy as the ping rate is relatively high (~3.5 Hz).

This file had to be modified slightly in Excel. Two columns had to added: daten and heave.

The formula for daten is:

$$= A / 86400 + DATE(1970,1,1)$$

and it needs a custom format setting to: dd/MM/yyyy hh:mm:ss.0

lat and long must be formatted with 6 decimal places

This is saved as a .csv file (and if you wish to save the formulae as a .xlsx file).

	A	B	C	D	E	F	G	H	I	J
1	%	daten	lat	lon	pitch	roll	depth	heading	speed	heave
2	1661011924	20/08/2022 16:12:03.5	48.408065	-9.674087	-15.56	-1.102	219.456	292.658	1500	0
3	1661011924	20/08/2022 16:12:03.6	48.408065	-9.674088	-15.558	-1.123	219.449	292.692	1500	0
4	1661011924	20/08/2022 16:12:03.7	48.408064	-9.674089	-15.556	-1.138	219.443	292.726	1500	0
5	1661011924	20/08/2022 16:12:03.8	48.408064	-9.674091	-15.554	-1.148	219.437	292.761	1500	0
6	1661011924	20/08/2022 16:12:03.9	48.408063	-9.674092	-15.552	-1.157	219.43	292.795	1500	0
7	1661011924	20/08/2022 16:12:04.0	48.408063	-9.674093	-15.55	-1.169	219.423	292.83	1500	0
8	1661011924	20/08/2022 16:12:04.1	48.408062	-9.674094	-15.547	-1.187	219.415	292.864	1500	0
9	1661011924	20/08/2022 16:12:04.2	48.408061	-9.674096	-15.544	-1.206	219.406	292.898	1500	0
10	1661011924	20/08/2022 16:12:04.3	48.408061	-9.674097	-15.542	-1.218	219.396	292.933	1500	0
11	1661011924	20/08/2022 16:12:04.4	48.408060	-9.674098	-15.541	-1.221	219.387	292.967	1500	0
12	1661011925	20/08/2022 16:12:04.5	48.408060	-9.674099	-15.538	-1.219	219.378	293.001	1500	0
13	1661011925	20/08/2022 16:12:04.6	48.408059	-9.674101	-15.535	-1.215	219.369	293.036	1500	0
14	1661011925	20/08/2022 16:12:04.7	48.408058	-9.674102	-15.532	-1.208	219.36	293.07	1500	0
15	1661011925	20/08/2022 16:12:04.8	48.408058	-9.674103	-15.528	-1.199	219.353	293.104	1500	0
16	1661011925	20/08/2022 16:12:04.9	48.408057	-9.674104	-15.525	-1.193	219.343	293.138	1500	0
17	1661011925	20/08/2022 16:12:05.0	48.408057	-9.674106	-15.521	-1.185	219.335	293.173	1500	0

Fig. 6.6 Example of adapted .csv navigation file

Occasionally the Autosub5 logged times revert to a start date of 1st January 1970. These pings will not be used in the mosaic unless navigation data can be created for the appropriate date and time. If large chunks of data are missing (typically 4min 27 secs!) separate s7k files should be extracted (stage 2). A new navigation file needs to be created for the 1970 data. This requires a calculation of the difference between modern time and 1970 times.

Table 6.2 Example of time error in Autosub5 navigation data, and suggested correction

ping	Logged time	Time difference
136981	21/08/2022 21:32:00	
136982	01/01/1970 12:59:46	19226 days 08:32:14

Giving a formula of:

$$= A / 86400 + DATE(1970,1,1) - TIME(8,32,14) - 19226$$

Note: an improved navigation file for each mission ('BestNav') was created by the AUV team between 24 and 48h after each mission. This was based on USBL positions and back-propagated errors (see section 7.1). However, for quick processing and mission planning, the above procedure was applied temporarily to several missions during the cruise.

Stage 4: Bathymetry import to Qimera

The 4th stage of the process was carried out in Qimera (current version 2.4.3). A new project had to be created for each AUV mission. For geodetics a Single projected coordinate system was used:

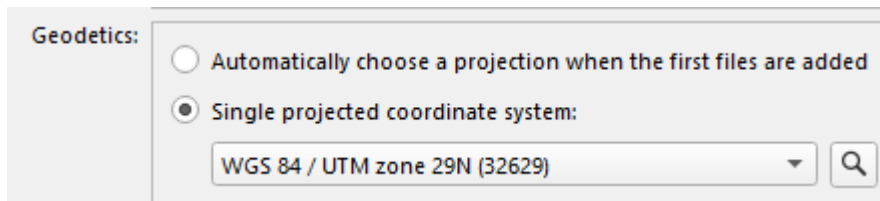

Fig. 6.7 Screenshot of coordinate system settings for the new Qimera project

Part 1 - import of the raw sonar files (.s7k) . The vessel name was given as "autosub". The question to process these files (blue bar) popped up, but as there was no position, motion, heading or depth information, nothing happened when pressing Yes or No to remove. Note: the option "Don't ask again" should not be chosen, as the files will have a ↻ symbol beside it, meaning they still need to be processed.

Part 2 – import of the navigation file(s) (.csv) – using the menu options Source – Import – Import ASCII Navigation. This required the Custom ASCII Configuration. The Date/Time Column 2 had to have the Options set to dd/MM/yyyy hh:mm:ss.s

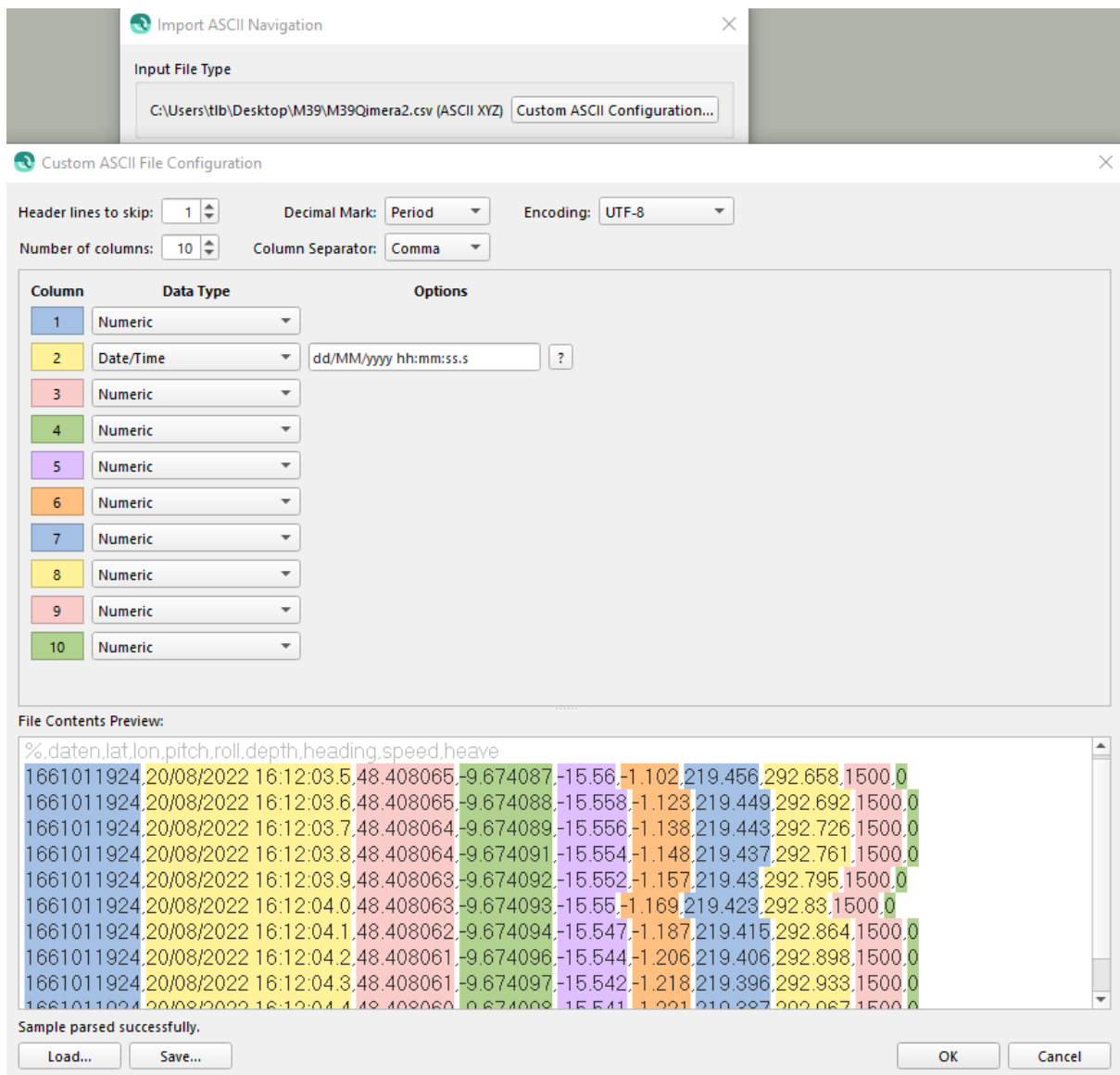

Fig. 6.8 Screenshot of the navigation input in Qimera

Once accepted, the option Change Mappings... should be chosen. In the file configuration the columns were mapped to the correct Mapping options.

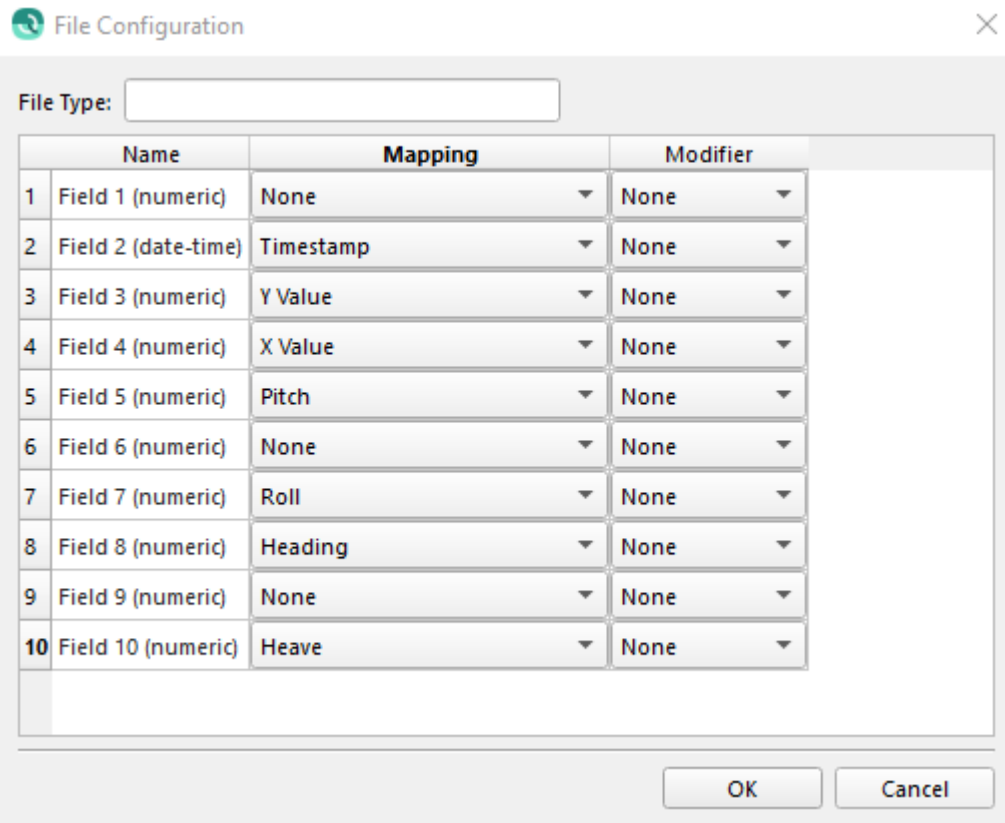



Fig. 6.9 Example illustrating how the columns of the navigation file are mapped onto the right fields

Finally the System References of Position, Motion and Depth for extraction had to be set. For this the  button for each of the system references was chosen, and names were added for all three (e.g. pos1, motion1 and depth1). Only two of the values needed to be altered:

“Forward” to 2.925 m and “Up” to 0.040 m

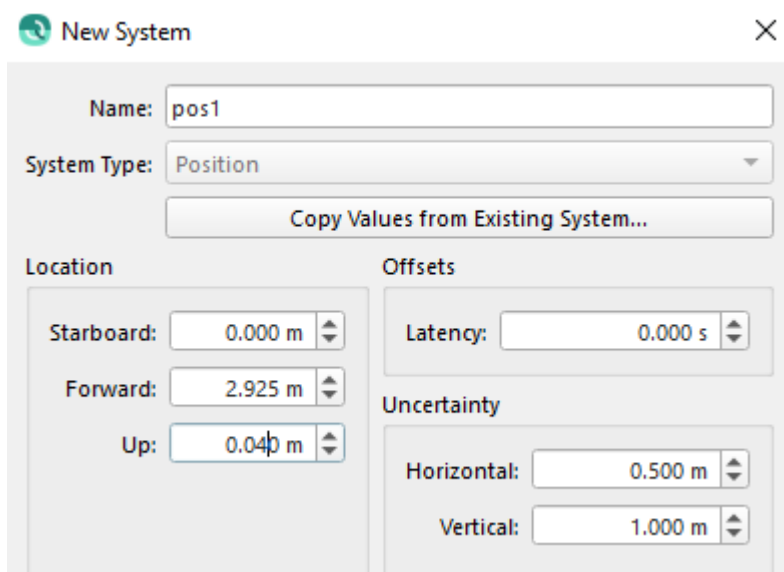

Fig. 6.10 System position settings used for the Norbit MBES processing in Qimera

Once all three system references were complete, all the Extract buttons were ticked 'on' before hitting the final OK button.

Import ASCII Navigation

Input File Type
C:\Users\tlb\Desktop\M39\M39Qimera2.csv (ASCII XYZ) Custom ASCII Configuration...

Field Mappings

Time Field 2 (date-time)
X Field 4 (numeric)
Y Field 3 (numeric)
Roll Field 7 (numeric)
Pitch Field 5 (numeric)
Heading Field 8 (numeric)
Heave Field 10 (numeric) Meters
Depth Field 6 (numeric) Meters
Height Not Set Meters
Delayed Heave Not Set Meters
Pressure Not Set bar
Change Mappings...

Vessel
Vessel Assignment: autosub

Position System Reference
System: pos1
Extract: Position

Motion System Reference
System: motion1
Extract: Motion
 Heading

Depth System Reference
System: depth1
Extract: Depth

Priority
 Use as primary source for applicable files

Coordinate System of the Imported Data
WGS 84 EPSG: 4326

OK Cancel

Fig. 6.11 Final settings for the navigation import in the Qimera software

This then started the processing of the s7k and added the navigation and other data to the files. This required to choose the 'Yes' button to question "Would you like to reprocess the affected files now".

Stage 5: Qimera grid creation

The bathymetry processing was automatic and took a few minutes. Then the Raw Sonar files were chosen (click and shift click until all are blue), after which the options Menu item – Dynamic Surface - Create Dynamic Surface were used, initially just with the default values.

Qimera provides many options for cleaning and improving the data grid. We selected the Project Layers tab and the Dynamic Surface that had been created. The properties of that surface should appeared:

Options:

- Shading Parameters: Set Altitude to 90°
- Colormap: left click to Adjust Colormap Range...
- Reduce range of across-track data: Select the source data files and right click to get menu and select Edit processing settings...

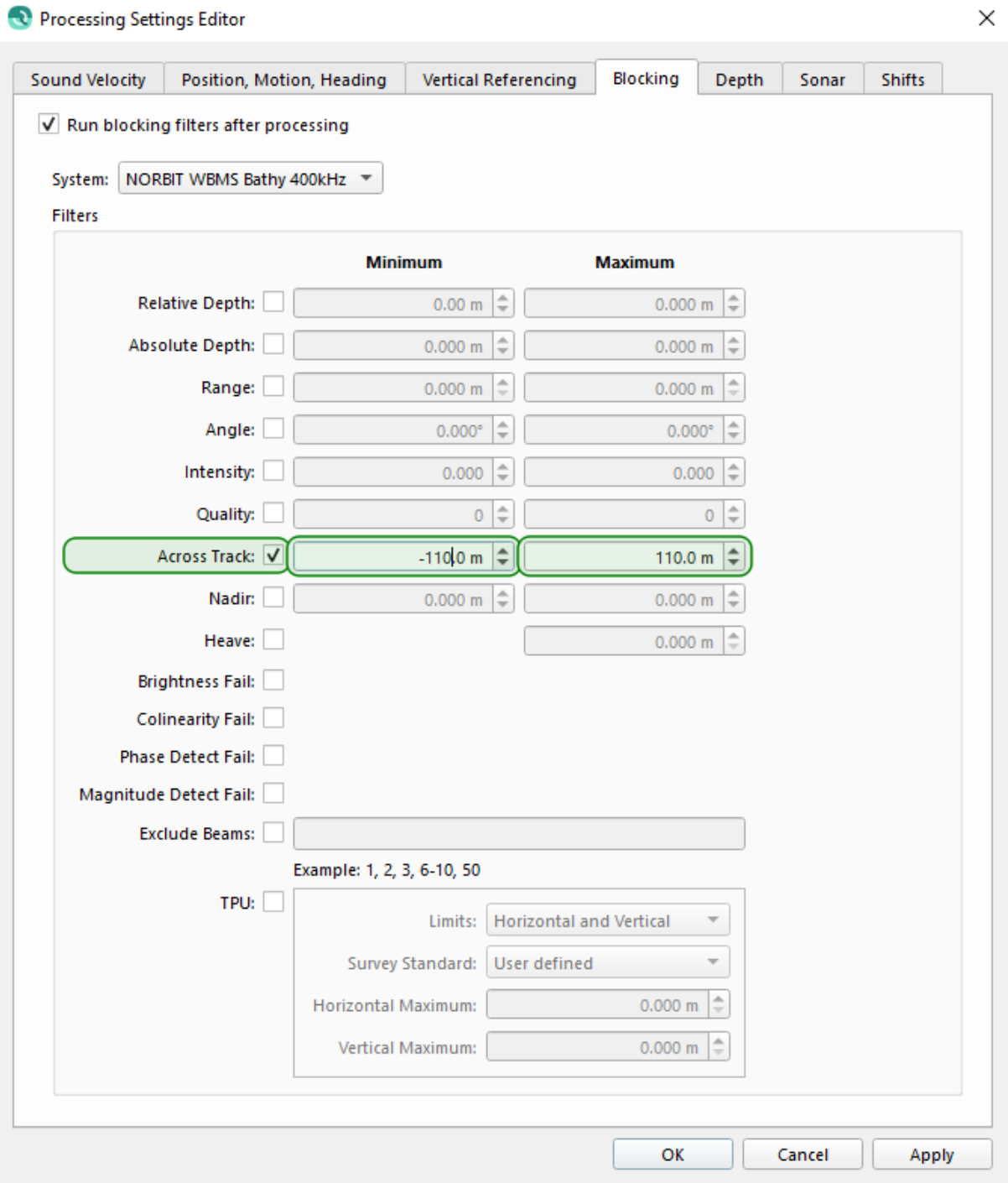





Fig. 6.12 Screenshot of the Qimera processing settings chosen for the Autosub5 Norbit MBES data

Choosing OK and then Yes to question “Would you like to reprocess the affected files now”, gave the following options:

- Tick the Colinearity Fail points: Similar to above processing settings. Can be done at the same time as the above.

- Use the various point editing tools:    to select an area and the  to launch the 3D editor. Use the shift plus mouse drag to rotate either up and down or side to side. Other editors are available – users choice and preference.

Stage 6: Data Export (e.g. to GIS)

Two types of data export were required. Firstly the Project Sources had to be exported to .gsf files for processing in FMGT (backscatter processing). They were written to the Export directory of the project (usually found in C:\Users\\QPS-Data\Projects\

Export of the bathymetry grid required the Project Layer to be highlighted. Menu item Export - Dynamic Surface – Export to Surface

We chose the Export Floating Point GeoTIFF Grid and No Data value ticked as a NaN

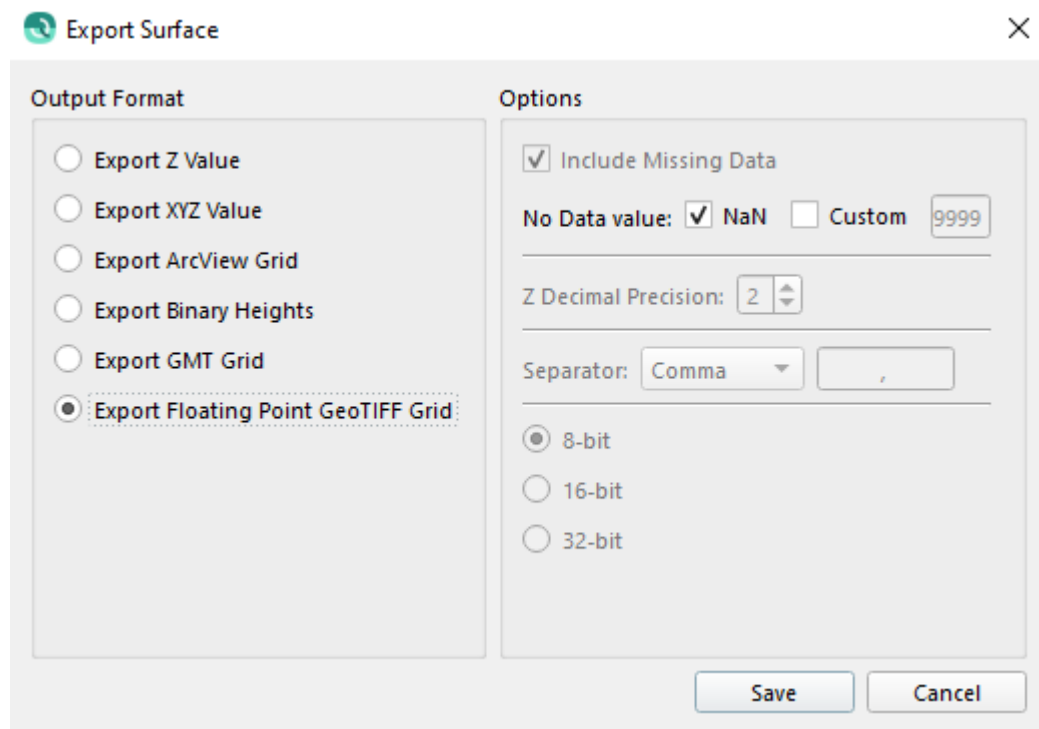

Fig. 6.13 Qimera settings for export of the processed grids.

Stage 7: Further Data Manipulation

Qimera has several extra data manipulation tools (under license), which were used to help with the data processing:

Menu item: Layers – Contouring.. To produce line contours on the dynamic surface

Menu item: Tools – Dynamic Surface Shifts – Static Horizontal Shift Tool To re-navigate the data pieces after incorrect positional data

Menu item: Tools – Wobble Analysis tool... To test the voracity of the vessel timings and lever arm settings and reset. Often used to correct the navigation offset between Multibeam time and SprintNav. Values usually about -1.0 second

Menu item: Tools – TU Delft Sound velocity inversion To correct far range differences (frowns and smiles) caused by sound speed error

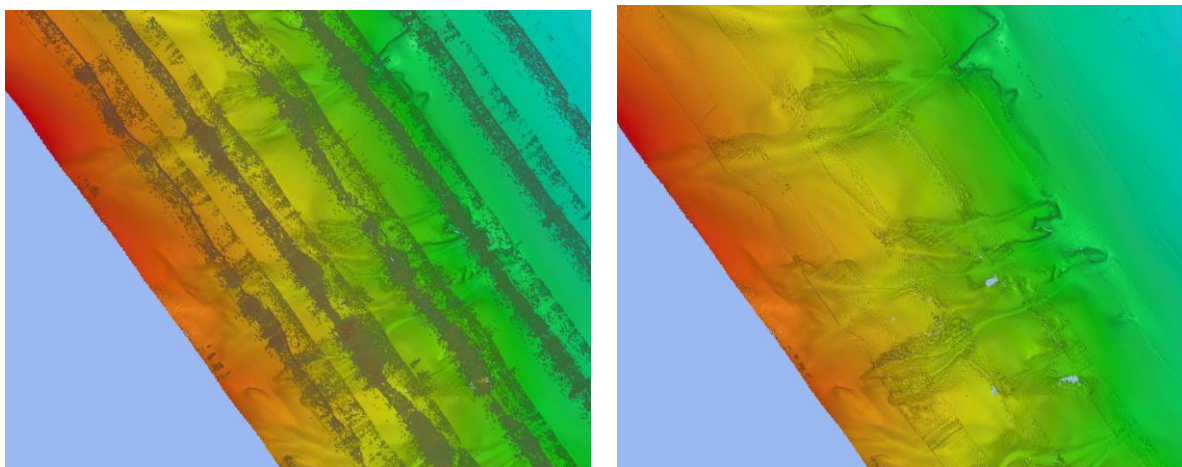

Fig. 6.14 Example of Norbit data processing results: Unprocessed multibeam bathymetry (left), Cleaned Multibeam Bathymetry (right)

JC237 Norbit Multibeam Raw Data Results

The Norbit Multibeam was run at 400kHz at all times along with the sidescan sonar (also at about 400kHz). Some interference from the sidescan sonar was manifest on the bathymetry data if the priority was given to the sidescan over the bathymetry. However if bathymetry was given the priority over the sidescan, the interference was minimal. All multibeam surveys were designed for 50m altitude but also collected data at the 15m altitude when the sidescan was optimal and during any photo survey lines, as it could not be switched off.

Table 6.3 AUV missions and sensors used

Mission	Multibeam altitude	Sidescan Sonar	Photography	ROSCI	
A5M31	x	✓			

A5M32	x		✓		
A5M33	75m, 50m, (15m)	✓			
A5M34	50m, (15m)	✓			
A5M35	50m, (15m)	✓			
A5M36	50m, (15m)	✓			
A5M37	50m, (15m)	✓			
A5M38	50m, (15m)	✓			
A5M39	50m, (15m)	✓	✓		
A5M40	50m, (15m)	✓			
A5M41	x		✓		
A5M42	x		✓		
A5M43	x		✓		
A5M44	50m, (15m)	✓	✓	✓	
A5M45			✓		

Table 6.4 Overview of the processed AUV multibeam datasets

Mission	s7k files	Pings	Colloquial Name
M33	14	6812 - 72067 , 74163 - 195912	Sand Waves
M34	22	13694 - 227505	Explorer Canyon
M35	7	56518 - 129038	Acesta Wall Canyon
M36	1	18276 - 21642	Acesta Wall Canyon
M37	11	18256 - 21671 , 29409 - 31009 , 52884 - 70171 , 76573 - 127258 , 137715 - 142410 , 143157 - 159377	Acesta Wall Canyon
M38	2	14605 - 28220	Acesta Wall Canyon
M39	3	8317 - 64584	Interfluve
M40	13	25849 - 240111 (136982 - 137683 & 144577 - 145279 in 1970)	Coral Wall Canyon
M41	2	28942 - 43936	Mini Mounds
M42			PAP northern Area
M43			PAP southern Area
M44	5	8411 - 74550 , (76146 - 162012)	Sand Waves
M45			Sand Waves

Final comment

During data exploration, it was noticed that the AUV depth measurements had a ca. 4 second delay compared to the CTD depth measurements (Fig. 6.15). This will require further investigation post-cruise.

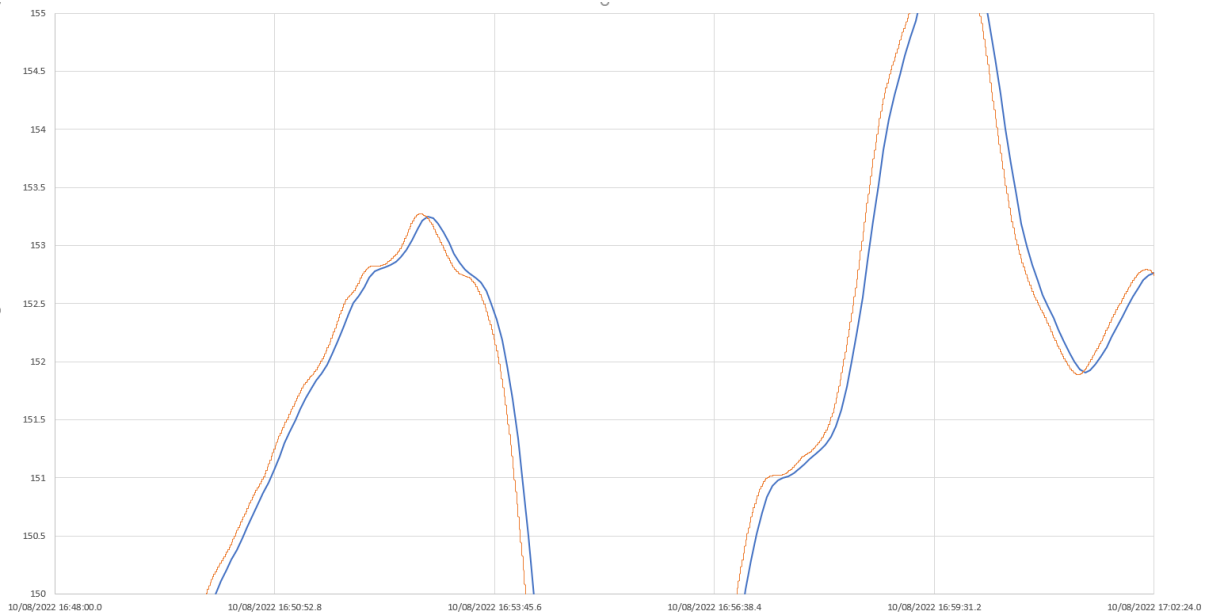

Fig. 6. 15 Extract of CTD depth data (blue) and AUV navigation depth (orange) – about a 4 second delay.

6.1.4. Autosub5 Sidescan (Catherine Wardell, Tim Le Bas)

Sidescan sonar data were acquired using the EdgeTech 2205 Sidescan Sonar, mounted on the Autosub5 AUV. Low frequency (120kHz) was used at 50m altitude whilst mapping canyons in conjunction with MBES data acquisition. High frequency (400kHz) sidescan was used at 15m altitude in flatter terrains. Files of 500MB were produced by OCS during the data acquisition, however, these could often not be opened in SonarWiz due to navigation errors caused by the software splitting the tracks into sections that did not contain the necessary file information. Instead, files were split based on mission track number during data acquisition, this split the files with appropriate file information (header/ footer etc), allowing the data to be opened in SonarWiz. The produced .jsf files were opened in SonarWiz where bottom tracking and an empirical gain normalisation (EGN) were applied. The mosaics were exported as 8-bit .tifs of 0.5m resolution (high frequency SSS) or 2m resolution (low frequency SSS).

A5M31- Mini mounds

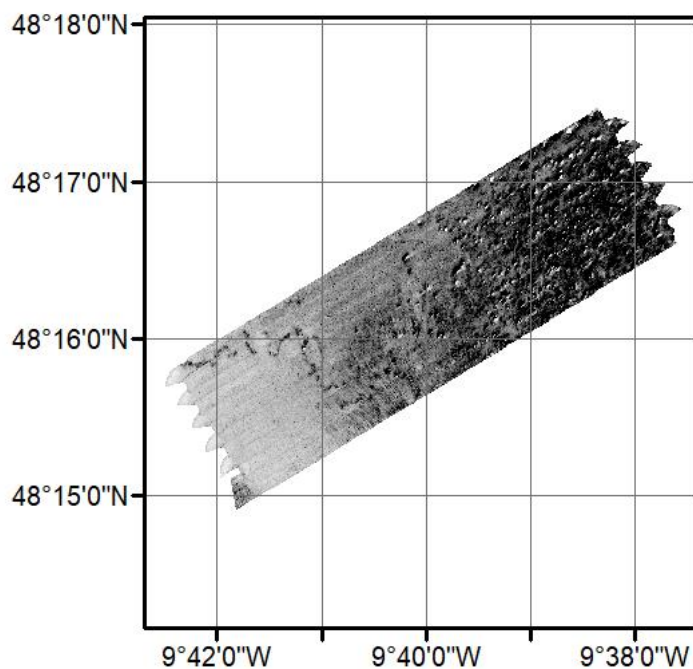

Fig. 6.16 A repeat survey of the JC125 M89 mini mound region was conducted at 15m altitude using high frequency sidescan on the 8-9th August. Data navigation of each track aligned well within itself and matched previously acquired data.

A5M33 Sandwaves

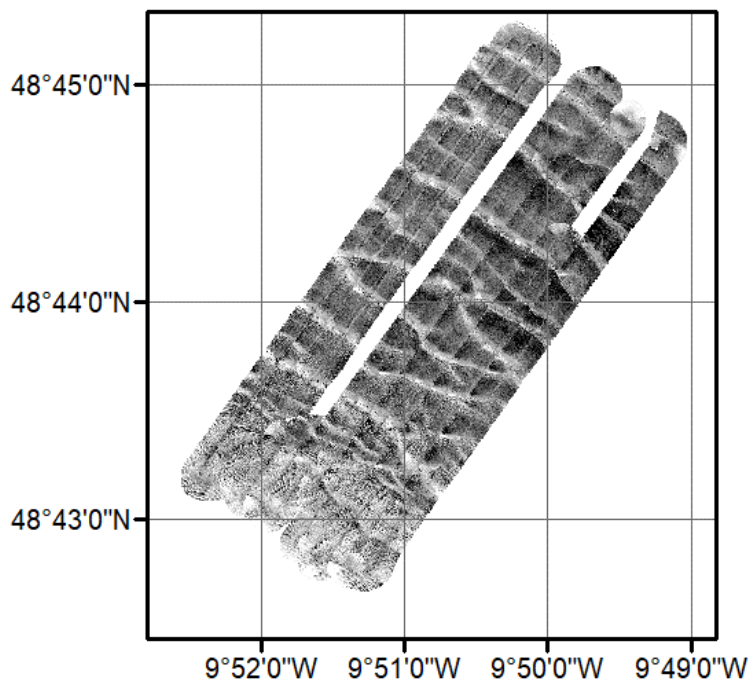

Fig. 6.17 A repeat of the eastern section of the JC125 M88 was conducted at 15m altitude using high frequency sidescan on the 10-11th August. The western strip of missing data occurred due to the incorrect timeout value being entered into the mission plan. The eastern strip of missing data occurred due to the port thruster breaching the current limit and turning off, the starboard thruster couldn't reach the assigned waypoint in the high currents. Data navigation of each track aligned well within itself and matched previously acquired data, extending the coverage to the NW and SE.

A5M34 Explorer Canyon

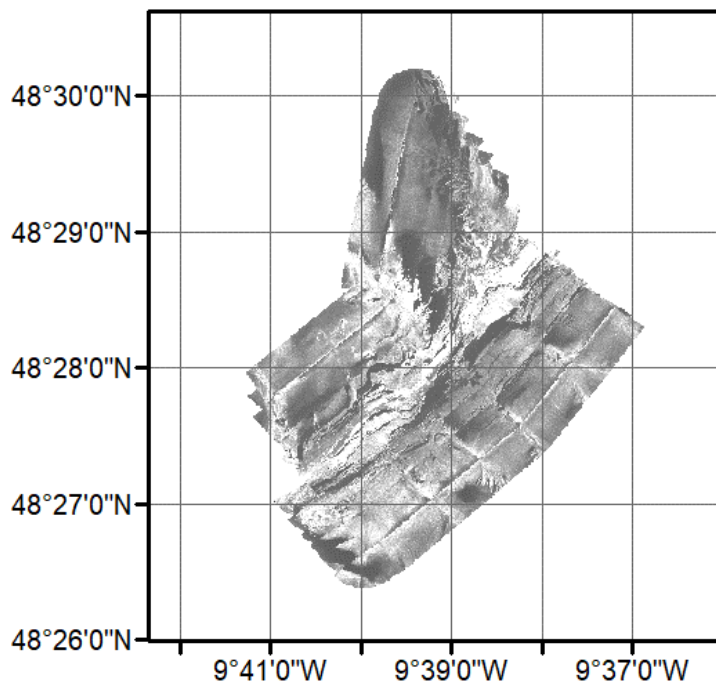

Fig. 6.18 Autosub5 Mission 34 was conducted on the 12-13th August to map the Explorer Canyon at varied (50-90m) altitudes using the low frequency sidescan. The altitudes were selected to account for the canyon terrain, proximity to cliffs and safety of the AUV. Adjustment of navigation is required to improve the mosaic. Given that this dataset was acquired together with MBES data, feature matching of the latter may help in extracting better navigation.

A5M35-38 Acesa Canyon

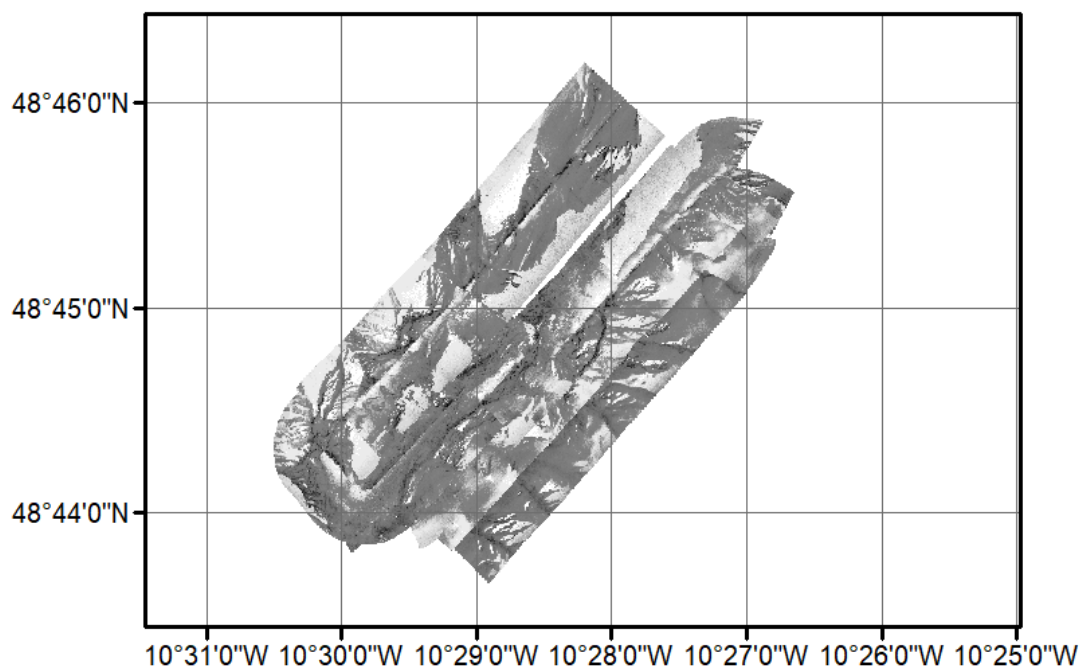

Fig. 6.19 The Acesa Canyon was mapped as part of 4 missions due to multiple Autosub5 aborts caused by spurious minimum altitude readings from the DVL (A5M35, A5M36, A5M38) and triggered dive timeouts (A5M37). These missions were completed at varied (50-90m) altitudes using the low frequency sidescan. The altitudes were selected to account for the canyon terrain, proximity to cliffs and safety of the AUV. Navigation adjustments required for positional agreement between missions.

A5M39 Mini mounds

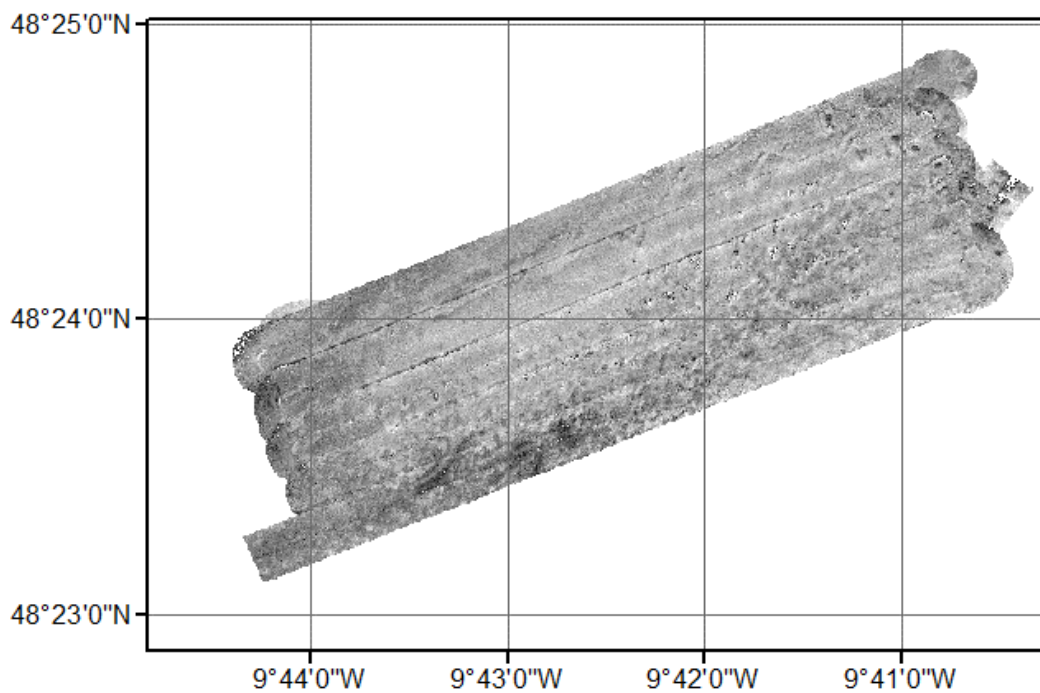

Fig. 6.20 M39 was conducted at 15m altitude using high frequency sidescan on the 20-21st August to map a second location of minimounds. Data navigation of each track aligned well within itself.

A5M40 Eastern Branch of Whittard Canyon

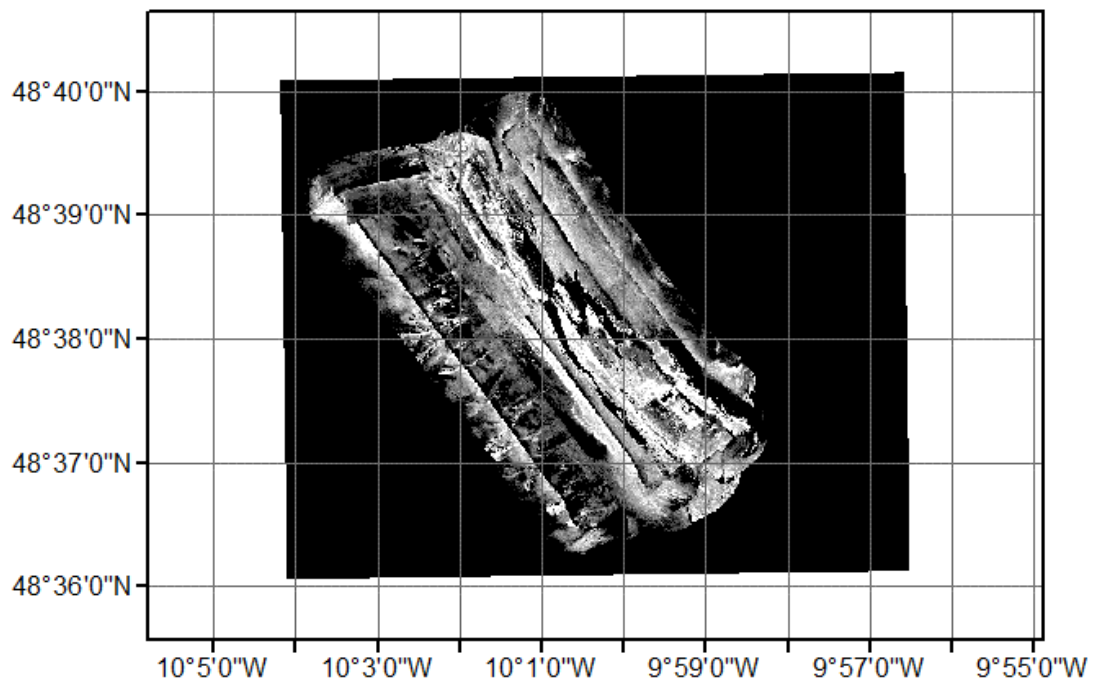

Fig. 6.21 The Eastern Branch of the Whittard Canyon was mapped on the 22-23rd August using low frequency sidescan at varied (50-90m) altitudes, selected to account for the canyon terrain, proximity to cliffs and safety of the AUV.

A5 M42 PAP Camera Survey1 and M43 PAP Camera Survey 2

Missions 42 and 43 were conducted at an altitude of 3m using the high-frequency sidescan sonar on the 26-27th (M42) and 28-29th (M43) August 2022 during camera surveys at PAP. Internal navigation required slight adjustments, but trawl marks were evident in the sidescan sonar data.

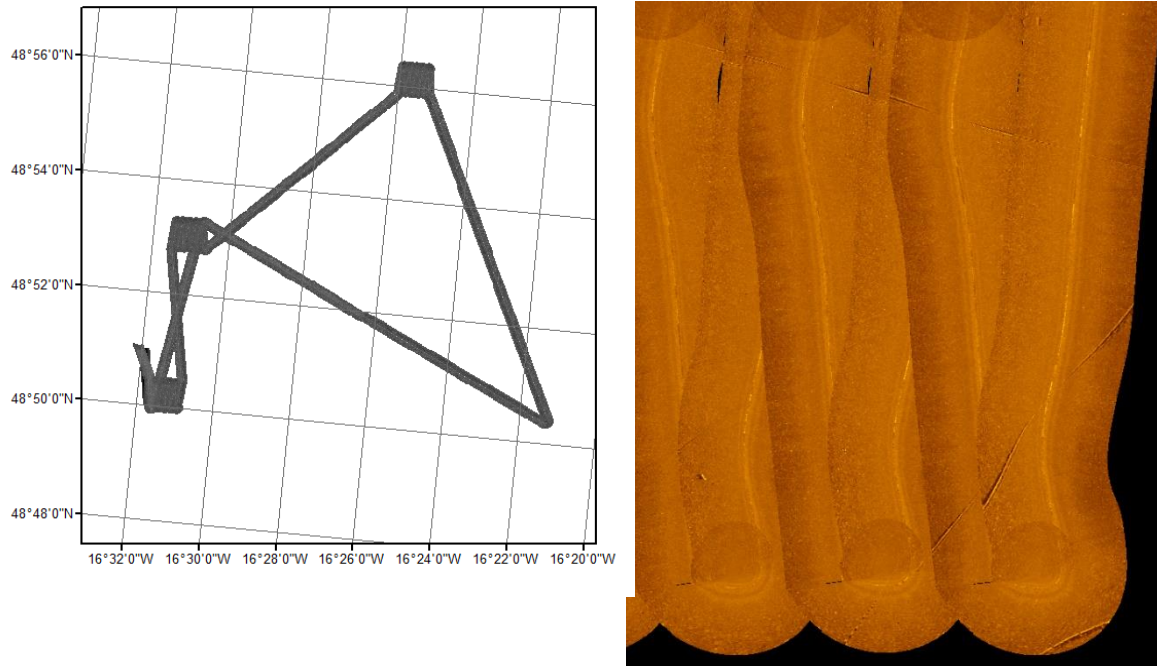

Fig. 6.22 Left: A5M42 PAP Camera Survey 1 sidescan sonar data. Right: detail of A5M42 PAP Camera 1 survey data showing trawl marks

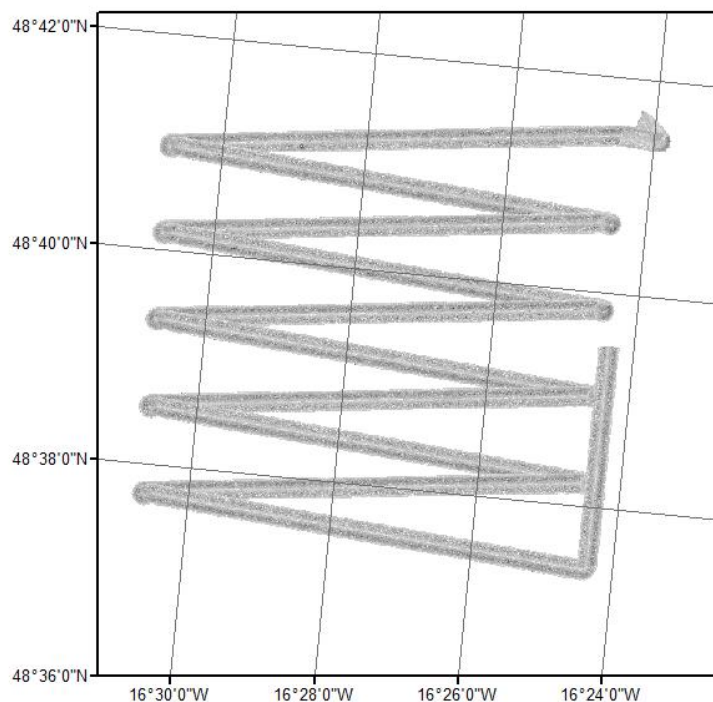

Fig. 6.23 A5M43 PAP Camera Survey 2

A5M44 RoCSi and Camera

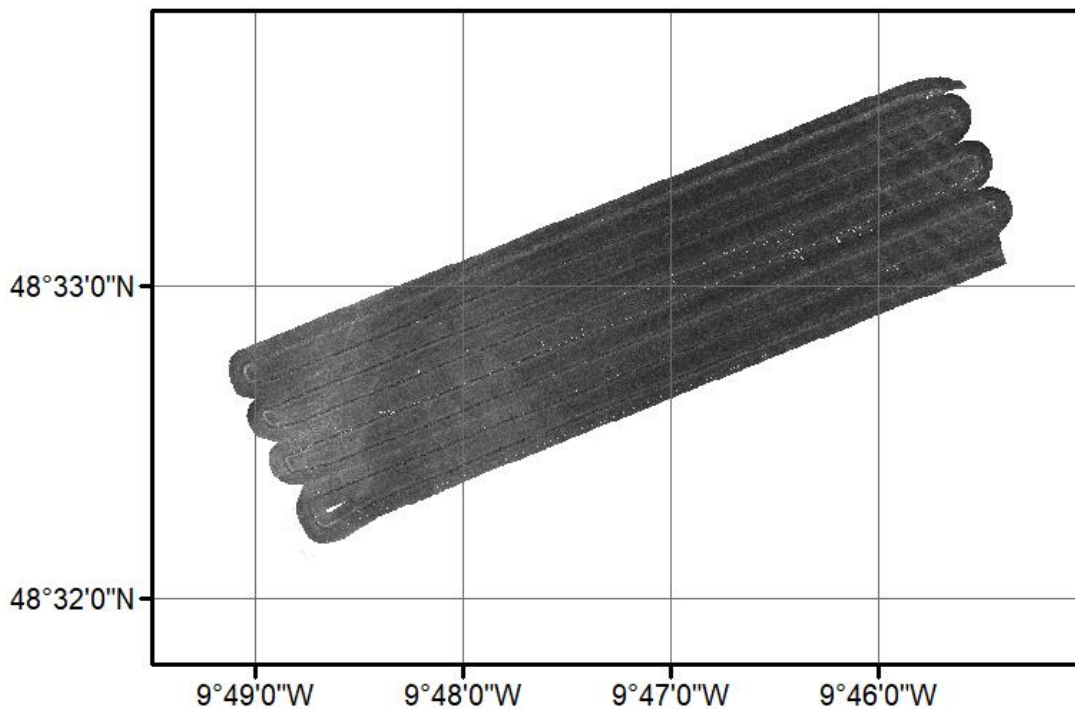

Fig. 6.24 A5M44 was conducted using high frequency sidescan sonar at an altitude of 15m on the 31st August- 1st September 2022, and covered part of the interfluve south of Explorer Canyon

6.1.5. Autosub5 SBP (Catherine Wardell, Tim Le Bas)

SBP data were recorded using the EdgeTech2205 Sub Bottom Profiler into .jsf files with navigation incorporated. Files of 500MB were produced by OCS during the data acquisition, however, these could often not be opened in SonarWiz due to navigation errors caused by the software splitting the tracks into sections that did not contain the necessary file information. Instead, files were split based on mission track number during data acquisition, this split the files with appropriate file information (header/ footer etc), allowing the data to be opened in SonarWiz. The produced .jsf files were opened in SonarWiz for a brief check whilst offshore and will be further investigated on return to land.

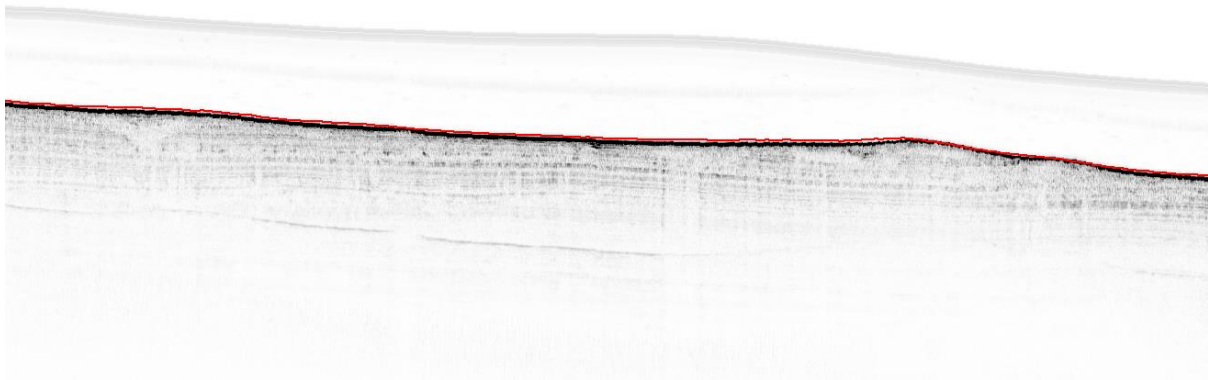

Fig. 6.25 Example of Autosub5 sub-bottom profiler data collected over the minimounds

6.1.6. ISIS Multibeam Bathymetry & Backscatter (Veerle Huvenne, Tim Le Bas, Catherine Wardell)

A Reson 7125 Multibeam was mounted vertically on the front of the Isis ROV for Dive 393, to map the vertical wall in the Acesta Canyon, repeating the survey carried out during JC125 (Robert et al., 2017), using the technique described in Huvenne et al. (2016). The ROV was the driven sideways in front of the near-vertical wall whilst ensonifying the wall from top to bottom. Several passes of the wall were completed at different distances from the wall (40m, 20m and 10m) and for the closer passes at different depths. This should allow a variety of maps of the wall to be created, with different resolutions. The S7K software, in combination with PDS2000, was used to acquire the multibeam data and recorded the data in .pds format in 500Mb chunks. Configuration of the software was done by copying the 2015 wall survey configuration, with some minor variations due to changes of the compass configurations on the Isis vehicle itself.

Eleven passes of the wall were completed at 0.2 knots. The last four passes were completed for photogrammetry rather than vertical MBES mapping. A higher speed of 0.3 was attempted but was not achievable (ROV flight was no longer smooth and stable at that speed).

Table 6.5 Settings used in the S7k software

	40 m distance	20 m distance	10 m distance
MBES frequency	400 kHz	400 kHz	400 kHz
Range	100 m	75 m	75 m
Power	200 dB	200 dB	199 dB
Max ping rate	10 p/s	10 p/s	10 p/s
Gain	25 dB	25 dB	25 dB
Pulse length	40 μ s	40 μ s	40 μ s
Horizontal Steering	0°	0°	0°
Coverage	120°	120°	120°
Absorption	90 dB/m	90 dB/m	90 dB/m
Spreading	30 dB	30 dB	30 dB
Sound velocity	automatic	automatic	automatic
Salinity	35	35	35
Speed	0.2kn	0.2kn	0.2kn

Table 6.6 Offsets for the various sensors versus a common reference point on the ROV (front of vehicle) as used for forward mapping approach (X: positive starboard, Y: positive fwd, Z: positive up, in the rotated frame, which corresponds to the Z offset, -X offset and -Y offset respectively in the conventional frame)

	X	Y	Z
Compatt (USBL, Beacon ROV2709)	1.46	-1.01	0.36
Doppler	-0.17	-0.58	2.19
Reson	0.34	-0.22	-0.12
Octans	-0.49	0.00	0.86
Parascientific (depth)	0.00	-0.55	1.48

Table 6.7 Overview of the different settings for each of the passes during the vertical mapping dive

Line nr	SOL	EOL	Distance		COG	Comments
	time GMT	time GMT	from wall (m)	Depth (m)		
1	20:16	21:57	40	655	218	0.2k, smooth line Power reduced to 199dB photogrammetry survey photogrammetry survey photogrammetry survey photogrammetry survey
2	22:08	23:27	20	710	38	
3	23:47	01:02	20	660	218	
4	01:20	02:55	20	610	38	
5	03:58	04:16	10	615	218	
6	04:25	04:49	10	650	38	
7	05:10	05:36	10	685	218	
8	05:44	06:12	4	653	38	
9	06:17	06:54	4	652	218	
10	07:00	07:55	4	650	38	
11	07:57	08:08	4	649	218	

Line nr	SOL				EOL				Dist (m)	Depth (m)	COG
	Lat Deg	Lat Min	Long Deg	Long Min	Lat Deg	Lat Min	Long Deg	Long Min			
1	48	45.670	10	27.423	48	45.444	10	27.692	40	655	218
2	48	45.441	10	27.688	48	45.675	10	27.457	20	710	38
3	48	45.663	10	27.409	48	45.440	10	27.675	20	660	218
4	48	45.439	10	27.668	48	45.667	10	27.407	20	610	38
5	48	45.567	10	27.504	48	45.505	10	27.592	10	615	218
6	48	45.508	10	27.395	48	45.578	10	27.498	10	650	38
7	48	45.577	10	27.504	48	45.508	10	27.611	10	685	218
8	48	45.508	10	27.988	48	45.570	10	27.499	4	653	38
9	48	45.570	10	27.501	48	45.505	10	27.591	4	652	218
10	48	45.500	10	27.589	48	45.571	10	27.498	4	650	38
11	48	45.570	10	27.498	48	45.506	10	27.590	4	649	218

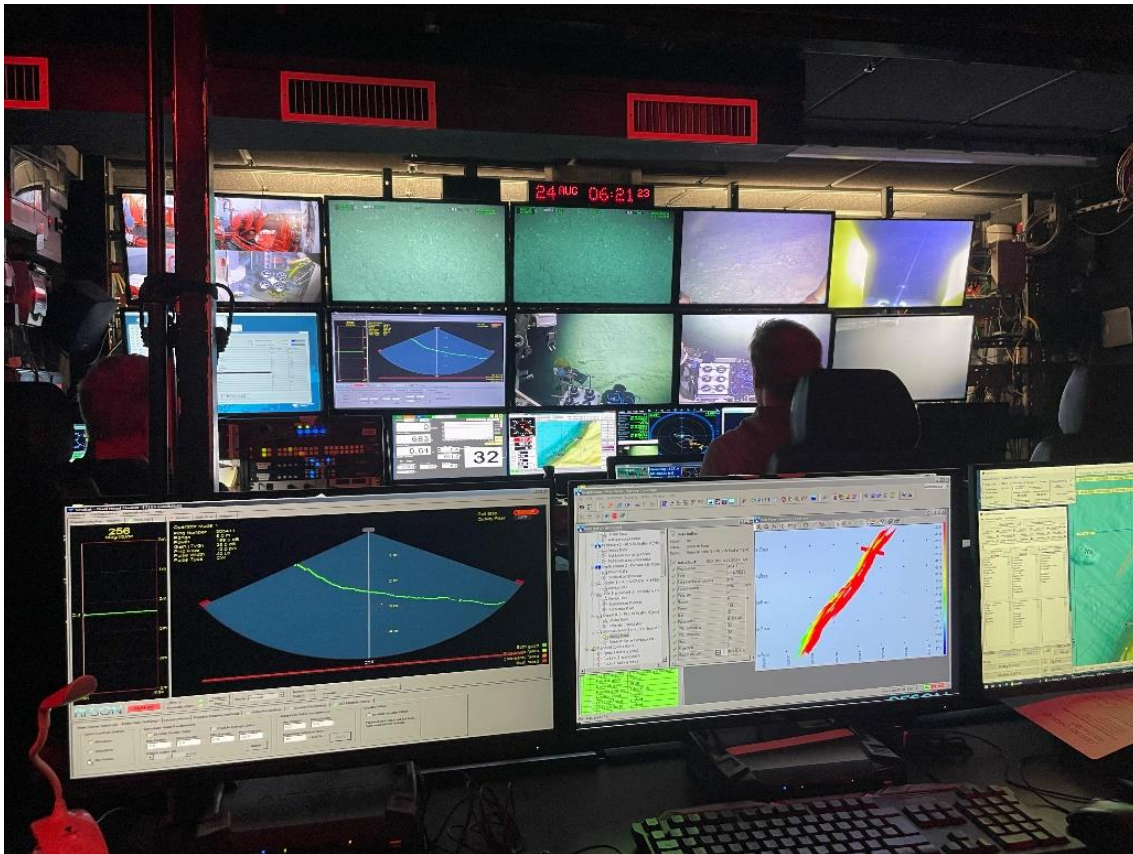

Fig. 6.26 Screen displays of the S7K (left) and PDS2000 (right) softwares during the vertical wall mapping ROV dive

The logging of data in this configuration does mean a transformational rotation is required to make the data understandable for any of the present-day multibeam processing software packages. It includes a swap of the records of roll, pitch and heading offset, and a reprojection of latitude, longitude and depth onto a vertical plane at a set distance from the wall. However initially a quick check of the data was done using LiteView (in the PDS software) and proved the data had been recorded successfully.

It was found that the .pds files were not immediately able to be converted to other formats such as .s7k or .xtf, as a crucial log file seemed to be missing in the PDS data structure. A workaround was created:

Conversion of .pds files to .xtf and .s7k (if not in fileset)

In the file structure, created by PDS2000, a new log file needed to be created (Fig. 6.27), which initially was empty. A convenient name was chosen, creating a file with .sub extension.

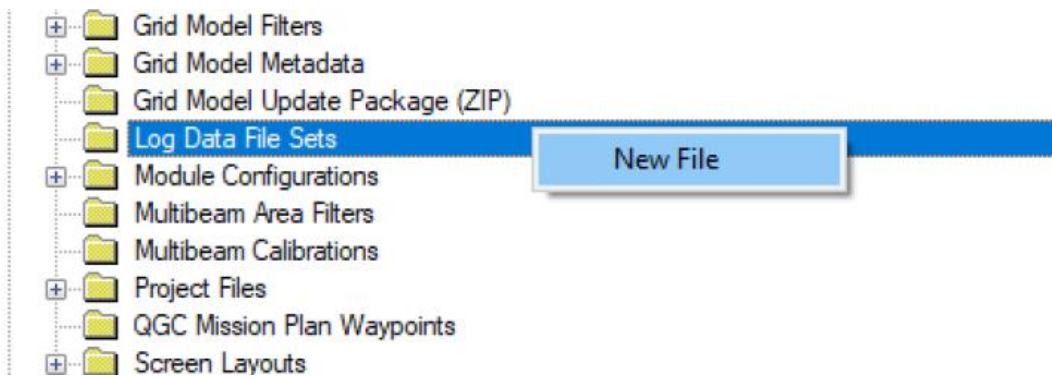

Fig. 6.27 Screenshot of the location in the file structure where the additional log file needs to be added in

In this new .sub file, which can be opened in an editor (Fig. 6.28), we then entered the list of .pds files (in the format as shown below in Fig.6.29) so the file selector could open the .pds log files. It was crucial that the file numbers started at 0.

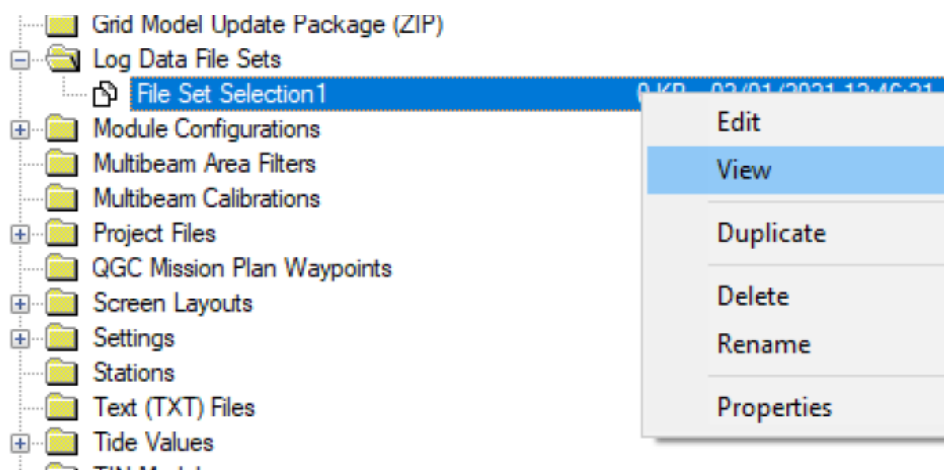

Fig. 6.28 Screenshot of file structure leading to the list of .pds files

```
[Files]
File(0) = LogData\rov[Multivessel Survey]_Line1.1-20220824-080510
File(1) = LogData\rov[Multivessel Survey]_Line1.1-20220823-202115
File(2) = LogData\rov[Multivessel Survey]_Line1.1-20220823-202621
File(3) = LogData\rov[Multivessel Survey]_Line1.1-20220823-203638
.....
```

Fig. 6.29 Example of the format used to create the list of .pds files

In order to perform the actual file conversions, we selected the newly create fileset in the File Set Editor (Processing ... Editing). No editing of the fileset was performed at this stage – just by selecting it the software created an internal indexing. This allowed us to select the files to export to .xtf or .s7k format

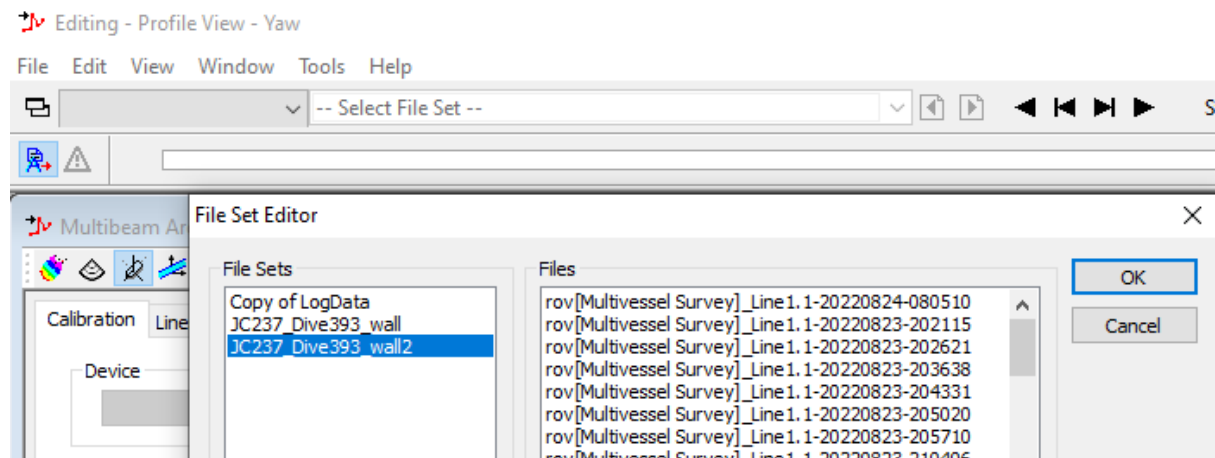

Fig. 6.30 Screenshot illustrating where to select the list of .pds files to convert to .s7k

In order to check for data presence and quality, the first few lines were entered into Qimera (v2.4.3) and the heading given a -90° offset, just to see the data in some kind of representation. Motion data were all uncorrected and thus the result was messy but viewable. The data were imported using the .s7k format and subsequently exported from Qimera into .gsf format. This then allowed the pair of .s7k and .gsf files to be used in FMGT (v7.10.1) for backscatter mapping. The backscatter mosaic was very poor with very little coherence of features but this was expected as the motion and positional data were uncorrected.

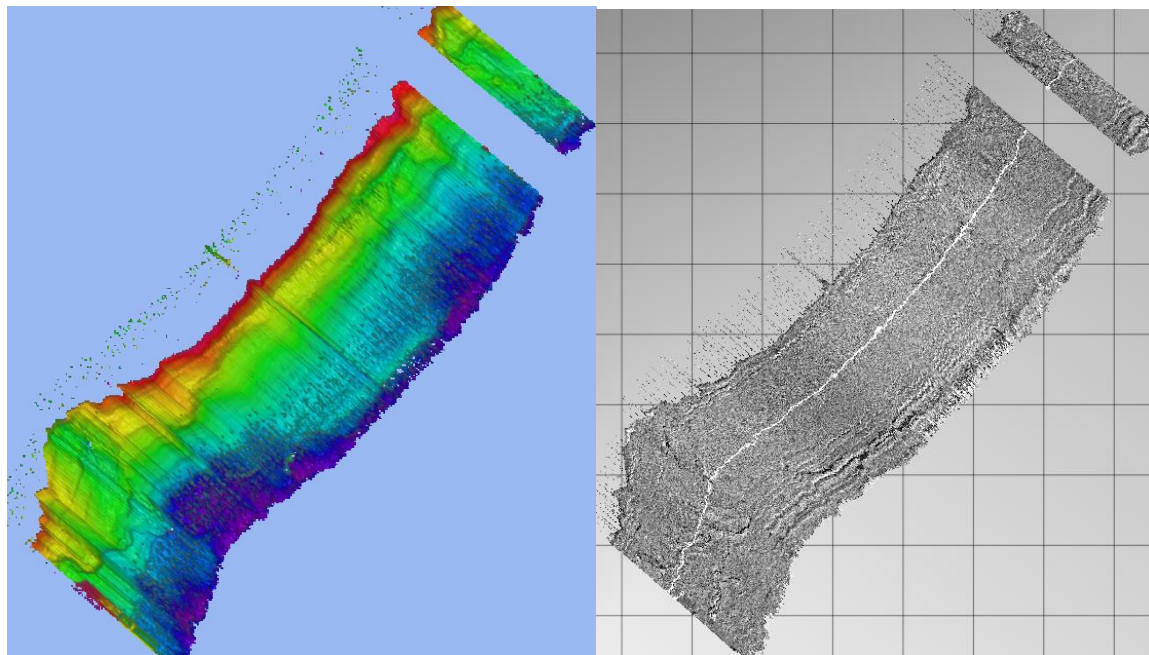

Fig. 6.31 Examples of the (uncorrected) vertical wall mapping data obtained during ROV Dive 393. Bathymetry (left) and backscatter (right).

Table 6.8 PDS file information for the vertical multibeam data collected on ROV Dive393

PDS2000 Number	PDS filename (& start time)	s7k Number	Line Nr
0	rov[Multivessel Survey]_Line1.1-20220823-172409		No Data
1	rov[Multivessel Survey]_Line1.1-20220823-173320	0	No Data
2	rov[Multivessel Survey]_Line1.1-20220823-173607	1	No Data
3	rov[Multivessel Survey]_Line1.1-20220823-174302	2	No Data
4	rov[Multivessel Survey]_Line1.1-20220823-174553	3	No Data
5	rov[Multivessel Survey]_Line1.1-20220823-185252	4	1
6	rov[Multivessel Survey]_Line1.1-20220823-201607	5	1
7	rov[Multivessel Survey]_Line1.1-20220823-202115	6	1
8	rov[Multivessel Survey]_Line1.1-20220823-202621	7	1
9	rov[Multivessel Survey]_Line1.1-20220823-203125	8	1
10	rov[Multivessel Survey]_Line1.1-20220823-203638	9	1
11	rov[Multivessel Survey]_Line1.1-20220823-204331	10	1
12	rov[Multivessel Survey]_Line1.1-20220823-205020	11	1
13	rov[Multivessel Survey]_Line1.1-20220823-205710	12	1
14	rov[Multivessel Survey]_Line1.1-20220823-210406	13	1
15	rov[Multivessel Survey]_Line1.1-20220823-211100	14	1
16	rov[Multivessel Survey]_Line1.1-20220823-211756	15	1
17	rov[Multivessel Survey]_Line1.1-20220823-212447	16	1
18	rov[Multivessel Survey]_Line1.1-20220823-213134	17	1
19	rov[Multivessel Survey]_Line1.1-20220823-213824	18	1
20	rov[Multivessel Survey]_Line1.1-20220823-214506	19	1
21	rov[Multivessel Survey]_Line1.1-20220823-215148	20	1
22	rov[Multivessel Survey]_Line1.1-20220823-220843	21	2
23	rov[Multivessel Survey]_Line1.1-20220823-221417	22	2
24	rov[Multivessel Survey]_Line1.1-20220823-221954	23	2
25	rov[Multivessel Survey]_Line1.1-20220823-222523	24	2
26	rov[Multivessel Survey]_Line1.1-20220823-223042	25	2
27	rov[Multivessel Survey]_Line1.1-20220823-223558	26	2
28	rov[Multivessel Survey]_Line1.1-20220823-224102	27	2
29	rov[Multivessel Survey]_Line1.1-20220823-224614	28	2
30	rov[Multivessel Survey]_Line1.1-20220823-225122	29	2
31	rov[Multivessel Survey]_Line1.1-20220823-225631	30	2
32	rov[Multivessel Survey]_Line1.1-20220823-230148	31	2
33	rov[Multivessel Survey]_Line1.1-20220823-230711	32	2
34	rov[Multivessel Survey]_Line1.1-20220823-231237	33	2
35	rov[Multivessel Survey]_Line1.1-20220823-231809	34	2
36	rov[Multivessel Survey]_Line1.1-20220823-232334	35	2
37	rov[Multivessel Survey]_Line1.1-20220823-234750	36	3
38	rov[Multivessel Survey]_Line1.1-20220823-235340	37	3

39	rov[Multivessel Survey]_Line1.1-20220823-235922	38	3
40	rov[Multivessel Survey]_Line1.1-20220824-000501	39	3
41	rov[Multivessel Survey]_Line1.1-20220824-001040	40	3
42	rov[Multivessel Survey]_Line1.1-20220824-001612	41	3
43	rov[Multivessel Survey]_Line1.1-20220824-002143	42	3
44	rov[Multivessel Survey]_Line1.1-20220824-002722	43	3
45	rov[Multivessel Survey]_Line1.1-20220824-003303	44	3
46	rov[Multivessel Survey]_Line1.1-20220824-003842	45	3
47	rov[Multivessel Survey]_Line1.1-20220824-004414	46	3
48	rov[Multivessel Survey]_Line1.1-20220824-004942	47	3
49	rov[Multivessel Survey]_Line1.1-20220824-005513	48	3
50	rov[Multivessel Survey]_Line1.1-20220824-010049	49	3
51	rov[Multivessel Survey]_Line1.1-20220824-012025	50	4
52	rov[Multivessel Survey]_Line1.1-20220824-012607	51	4
53	rov[Multivessel Survey]_Line1.1-20220824-013152	52	4
54	rov[Multivessel Survey]_Line1.1-20220824-013739	53	4
55	rov[Multivessel Survey]_Line1.1-20220824-014323	54	4
56	rov[Multivessel Survey]_Line1.1-20220824-014904	55	4
57	rov[Multivessel Survey]_Line1.1-20220824-015449	56	4
58	rov[Multivessel Survey]_Line1.1-20220824-020028	57	4
59	rov[Multivessel Survey]_Line1.1-20220824-020615	58	4
60	rov[Multivessel Survey]_Line1.1-20220824-021204	59	4
61	rov[Multivessel Survey]_Line1.1-20220824-021743	60	4
62	rov[Multivessel Survey]_Line1.1-20220824-022332	61	4
63	rov[Multivessel Survey]_Line1.1-20220824-022922	62	4
64	rov[Multivessel Survey]_Line1.1-20220824-023513	63	4
65	rov[Multivessel Survey]_Line1.1-20220824-024053	64	4
66	rov[Multivessel Survey]_Line1.1-20220824-024632	65	4
67	rov[Multivessel Survey]_Line1.1-20220824-025220	66	4
68	rov[Multivessel Survey]_Line1.1-20220824-034912	67	5
69	rov[Multivessel Survey]_Line1.1-20220824-035745	68	5
70	rov[Multivessel Survey]_Line1.1-20220824-040417	69	5
71	rov[Multivessel Survey]_Line1.1-20220824-041045	70	5
72	rov[Multivessel Survey]_Line1.1-20220824-042513	71	6
73	rov[Multivessel Survey]_Line1.1-20220824-043200	72	6
74	rov[Multivessel Survey]_Line1.1-20220824-043848	73	6
75	rov[Multivessel Survey]_Line1.1-20220824-044539	74	6
76	rov[Multivessel Survey]_Line1.1-20220824-051025	75	7
77	rov[Multivessel Survey]_Line1.1-20220824-051711	76	7
78	rov[Multivessel Survey]_Line1.1-20220824-052401	77	7
79	rov[Multivessel Survey]_Line1.1-20220824-053041	78	7
80	rov[Multivessel Survey]_Line1.1-20220824-054429	79	8
81	rov[Multivessel Survey]_Line1.1-20220824-055257	80	8
82	rov[Multivessel Survey]_Line1.1-20220824-060121	81	8
83	rov[Multivessel Survey]_Line1.1-20220824-060945	82	8

84	rov[Multivessel Survey]_Line1.1-20220824-061736	83	9
85	rov[Multivessel Survey]_Line1.1-20220824-062600	84	9
86	rov[Multivessel Survey]_Line1.1-20220824-063414	85	9
87	rov[Multivessel Survey]_Line1.1-20220824-064224	86	9
88	rov[Multivessel Survey]_Line1.1-20220824-065029	87	9
89	rov[Multivessel Survey]_Line1.1-20220824-065955	88	10
90	rov[Multivessel Survey]_Line1.1-20220824-070812	89	10
91	rov[Multivessel Survey]_Line1.1-20220824-071617	90	10
92	rov[Multivessel Survey]_Line1.1-20220824-072419	91	10
93	rov[Multivessel Survey]_Line1.1-20220824-073217	92	10
94	rov[Multivessel Survey]_Line1.1-20220824-074048	93	10
95	rov[Multivessel Survey]_Line1.1-20220824-074856	94	10
96	rov[Multivessel Survey]_Line1.1-20220824-075704	95	11
97	rov[Multivessel Survey]_Line1.1-20220824-080510	96	11

6.2. Video surveying and photography (Brian Bett, James Strong, Veerle Huvenne)

6.2.1. ROV-based video surveying

A total of 17 *Isis* ROV dives were conducted during JC237; 14 at Whittard Canyon and three at the Porcupine Abyssal Plain Sustained Observatory (Table 6.9).

Table 6.9 *ISIS* ROV dives conducted during JC237 at both Whittard Canyon (WC) and the Porcupine Abyssal Plain Sustained Observatory (PAP).

ISIS dive number	Site	Objectives	Specific location
382	WC	Deployment of ARMS and settlement panels	Interfluvium south of Dangaard Canyon
383	WC	Repeat of video transects and photogrammetry undertaken during JC125	Explorer Canyon
384	WC	Rock sampling (ROV drill) and video transects to ground-truth SDM	Explorer Canyon
385	WC	Video transects on flanks. Photogrammetry wasn't possible (too turbid)	Coral Wall in the Eastern Canyon
386	WC	Video transects	Mid-Dangaard Canyon
387	WC	Repeat of video transects and photogrammetry undertaken during JC125	Acesta branch in the Western-Middle Canyon
388	WC	Video transects	Knickpoint in the Acesta branch in the Western-Middle Canyon
389	WC	Video transects and nematode sampling	Knickpoint in the Western-Middle Canyon
390	WC	Video transects	Knickpoint in Explorer Canyon
391	WC	Video transects, attempt to repeat transects from JC125	SE of Coral Wall in the Eastern Canyon
392	WC	Video transects and rock sampling (ROV drill)	Knickpoint in Explorer Canyon
393	WC	MBES and photogrammetry, repeats of mapping from JC125	Acesta Wall in the Western-Middle Canyon
394	WC	Video transects	Dangaard Canyon
395	PAP	Video transects	Trawl sampled PAP area
396	PAP	Video transects	Debris flow and AESA abyssal hill
397	PAP	Video transects	Potential new PAP reference area ('PAP South')
398	WC	Video transects and photogrammetry	Eastern Canyon downslope of Explorer Canyon

During ROV dives, an extensive suite of data are recorded that describe all aspects of the operation: ROV USBL navigation, ROV Doppler navigation, depth, attitude, ship navigation,... These data are recorded in the central *Isis* database and stored in NetCDF format. At the end of each dive they are also converted into ASCII format and both sets of files are provided to the scientists to help with the analysis of the ROV video data. The most comprehensive files are the *Dive***.ISCSV* files, comma-separated files which contain the following parameters (following the columns that contain date and time information):

Field Name Units

Latitude deg

Longitude deg

csvX m
csvY m
Lat Origin deg
Lon Origin deg
Xutm m
Yutm m
UTM Zone
Depth m (Isis Parascientific Digiquartz Pressure Sensor)
Altitude m (Isis Kongsberg Altimeter)
Heading deg (Isis Octans, MRU)
Octans Pitch deg
Octans Roll deg
Xbw Head deg (Isis Crossbow compass)
Xbw Pitch deg
Xbw Roll deg
Wraps Number of turn in Isis umbilical

Unfortunately, the altitude sensor was faulty throughout the cruise. This meant that for the first 4 dives, there is no altitude information on the overlay, and the .ISCSV file has no information either. However, the altitude is also recorded by the RDI workhorse ADCP. Hence the information can be found in the files .CSVGA that contain the Doppler information. From Dive 385, these values were displayed on the overlay on the video feed of the HDSCI camera.

In addition, after the cruise it appeared that a reference coordinate had not been set correctly, which means that the Latitude and Longitude information of the .ISCSV files is not correct. It is better to use the .IGGA1 files (for USBL) or .CSVGA files (for Doppler nav), or the OFOP .posi files, although the latter may not have the same temporal accuracy (see also section 7.2.8).

6.2.1.1. ROV Camera setup

The video and photography set-up during JC237 was the same in principle as during JC125 and JC166. Imaging and lighting equipment (Fig. 6.32) carried by the *Isis* ROV included three optically corrected High-Definition (HD) cameras mounted to the front of the vehicle.

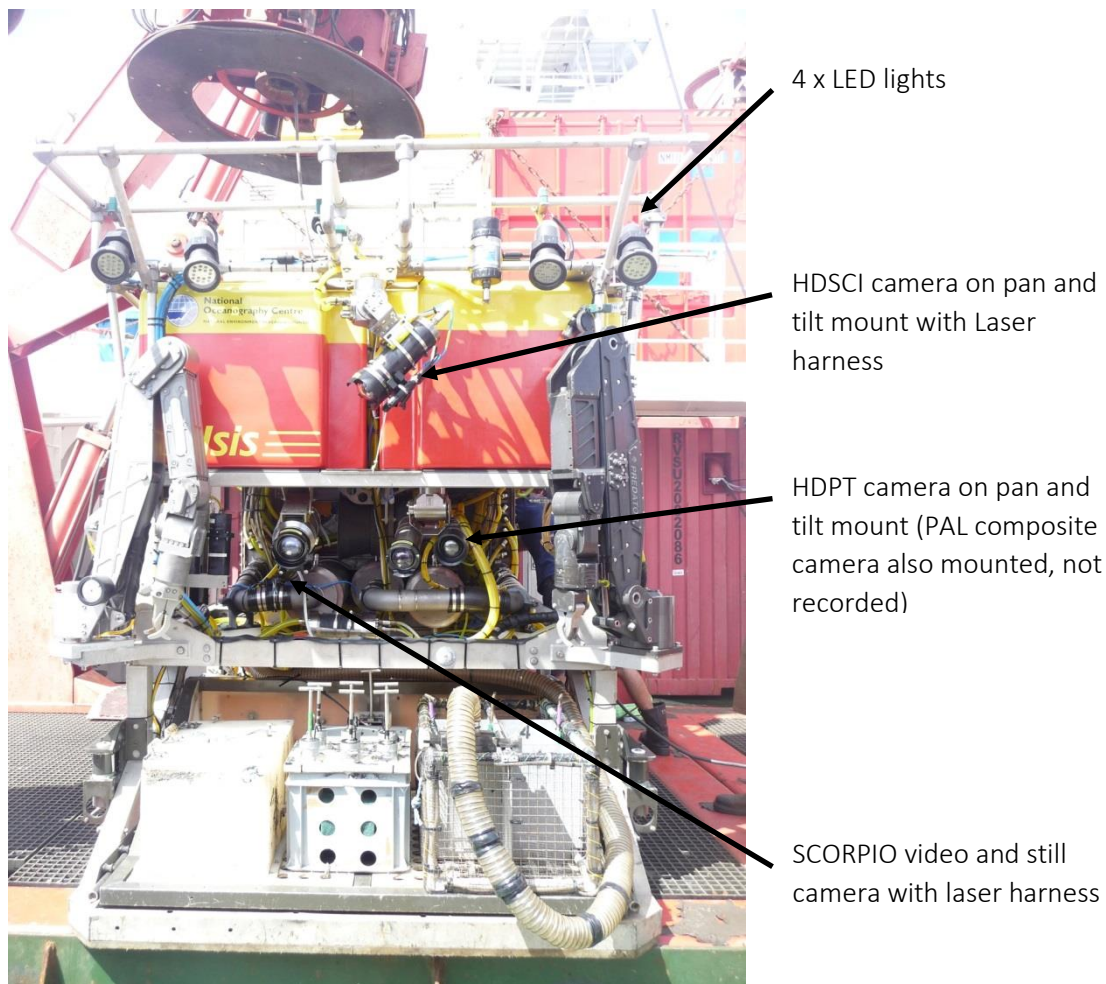

Fig. 6.32 Camera set-up on *Isis* ROV

The HDPT (HD Pilot) camera was mounted on a pan-and-tilt module central to the vehicle and was used primarily for piloting and sampling procedures. HDSCI (HD Science) was also mounted on a pan-and-tilt module above the HDPT, central to the vehicle. Watch leaders and the scientific party have full control of the pan-and-tilt and zoom functions of this camera during dive operations. The HD video and stills camera (SCORPIO) was mounted on a fixed bracket on starboard of the centre line of the vehicle. Other cameras on the *Isis* ROV used for piloting (generally not recorded for science) include numerous composite video cameras and one low-light aft camera.

Four LED lamps provided illumination for the cameras on a fixed-mount lighting bar at the front of the vehicle (Fig. 6.32). To provide a fixed scale in images, two sets of lasers were mounted 0.1m apart parallel to the focal axis of the HDSC and SCORPIO cameras. During video transects, the zoom level of the SCORPIO camera was kept such that the seabed area in the field of view was as constant as possible. This was attempted by keeping the distance between the laser dots to the same proportion of the width of field of view as much as possible. Given the oblique angle of the camera, this required zooming out a little on steep terrain, and zooming in on flatter ground.

All of the HD camera feeds correspond to an AQA dual KiPro recording deck in the *Isis* ROV control van. At the start of each dive the timecode was checked so that all videos are correctly time-stamped (GMT). In addition, on arrival at the seafloor, the internal timestamp of the SCORPIO camera was synced with that of the KiPro deck recording the SCORPIO HD feed. Each KiPro deck and camera has three corresponding 300GB solid-state drives (SSD). At the start of the cruise, it was decided that all three HD cameras feeds would be recorded (Apple ProRes 422, 1920 x 1080).

Recording would commence on deployment, and would continue to record on descent to the seabed. On the seabed, all three cameras were stopped simultaneously and the KiPro recording deck was changed to a second SSD. During operational dive hours, the video footage was recorded in approximately 2-hour files of ca. 110GB each. On approaching the seabed, the HDSCI, HDPT and SCORPIO cameras were white balanced to provide the best representation of true colour at the depth of the imagery being recorded. As soon as the vehicle left the seabed, the KiPro recording disks were changed again, to enable easier extraction of 'on bottom' footage.

During operational dive hours the SCORPIO camera was set to take stills images (4672 x 2628; 16:9 Format) every 30 seconds. The 'snap photo' command could be used on the DEVCON GUI to capture extra stills – this had no effect on the images taken at 30-second intervals.

6.2.1.2. Initial ROV Dive descriptions

A short description with depth profile and example photographs for each of the dives is listed below. Detailed maps of the different survey sites are added at the end of the document (Section 10).

ISIS Dive 382 Whittard Canyon

During the descent, *Capros aper* (boarfish) were abundant both in the water column and at the seabed (Fig. 6.34). The interfluvial seabed consisted of lightly rippled sediment with occasional patches of coral rubble (raised slightly). The settlement panels and ARMS were deployed on an area with a sparse cover of coral rubble, interpreted, from the forward scanning sonar, to be a coral mound.

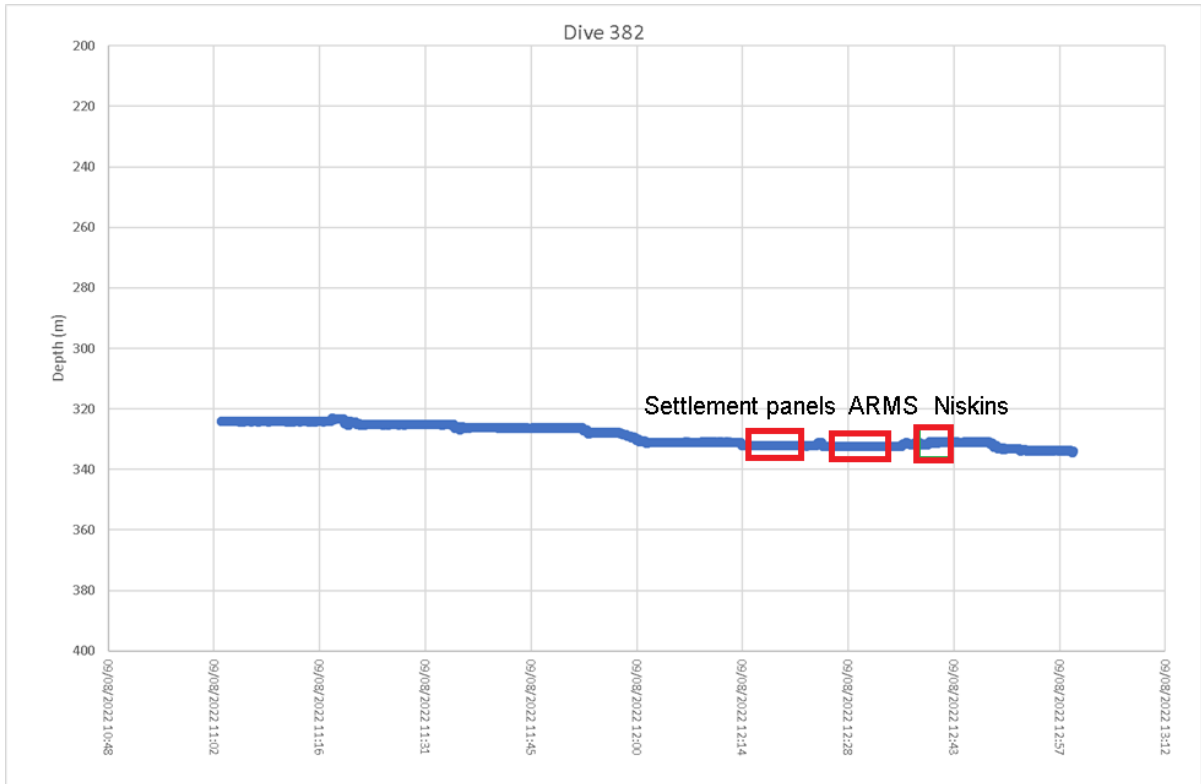

Fig. 6.33 Depth profile over time for ISIS ROV Dive382, annotated with sampling events (red boxes)

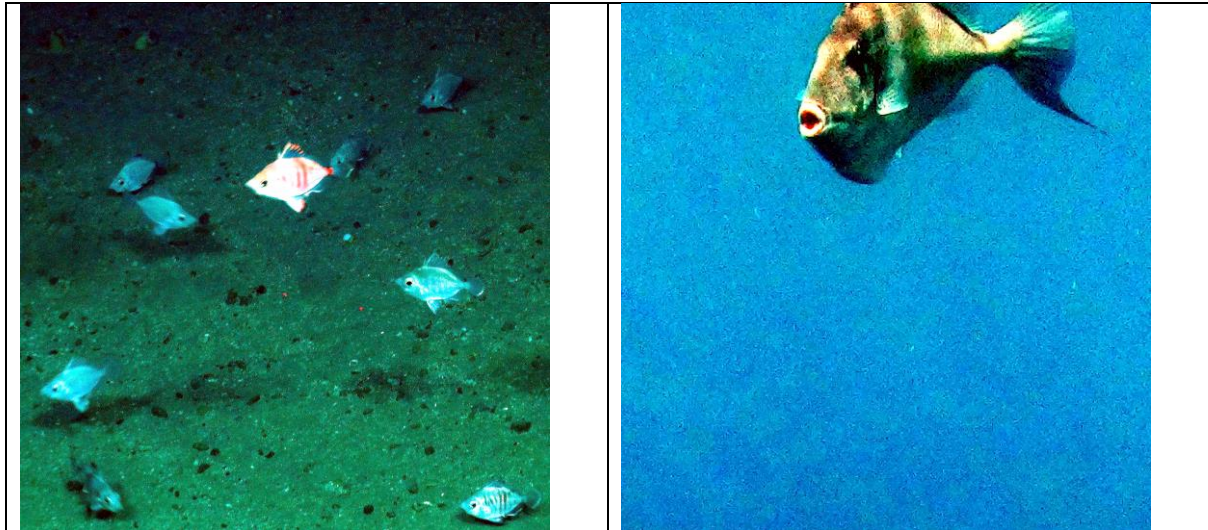

Fig. 6.34 Boarfish observed at the seafloor (left) and triggerfish observed at surface(right) during ROV recovery of Dive 382.

ISIS Dive 383

The substratum at the start waypoint, in the thalweg, was a firm-looking sandy sediment with asymmetrical ripples with occasional coral rubble patches. At the start of the canyon wall, the underlying, highly-stratified rock was exposed. Although mostly sparsely colonised, some of the exposed edges of the harder and thicker rock strata were colonised by cold-water corals and

cerianthid anemones. The bases of wall sections were often associated with large boulders and loose rock. Epifaunal abundance on the underside of rock overhangs was substantially greater than on the vertical surfaces. Vertical wall sections transitioned regularly into shallow ledges and more expansive slopes. Most slopes appeared to be composed of soft rock/firm clay with thin veneers of silt/sediment; epifaunal species were sparse on these surfaces. Towards the summit of this dive, dense cold-water hard coral aggregations (including the main ‘coral mound’ found in a previous survey) were present both on stiff clay walls and on moderately sloped mounds.

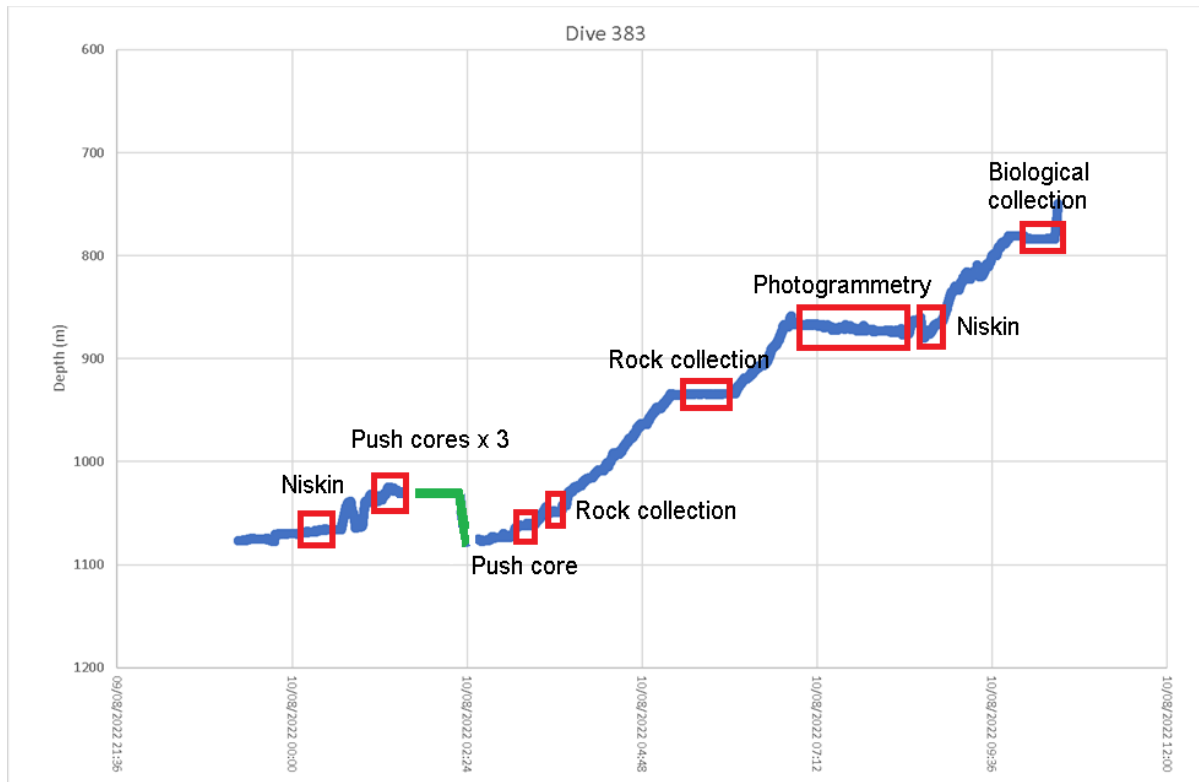
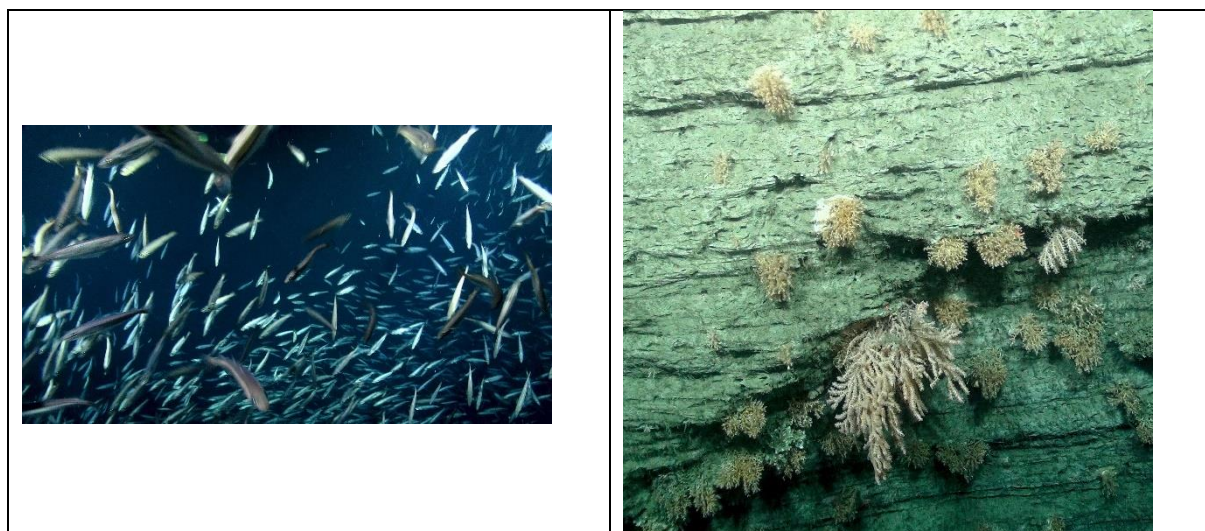

Fig. 6.35 Depth profile over time for ISIS ROV Dive 383, annotated with sampling events (red boxes) and mid-water transits (green track).



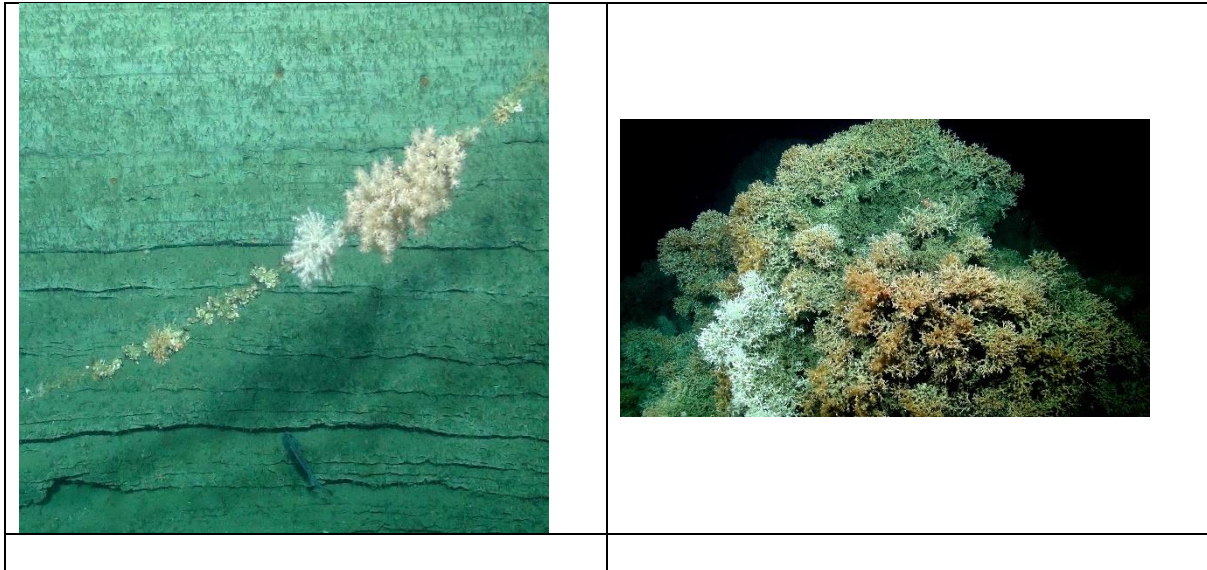

Fig. 6.36 Extensive shoal of blue whiting observed during descent; overhang-developed CWC growth; coral growth on spanned lost fishing gear; large coral framework on top of one of the small coral mounds inside the Explorer Canyon.

ISIS Dive 384

Substrata at the start point (canyon thalweg) were characterised by densely rippled sediment that appeared compacted and firm. The wall started abruptly and was comprised of stratified rock with a small amount of fractured and broken material at the base. The octocoral, *Acanella* sp., was present on the harder exposed edges of specific rock strata within the rock wall. Ledges, with a sediment drape and broken rock, appeared regularly whilst ascending the wall. The base of each wall section was littered with broken, loose rock (soft mudstone / stiff clay) and coral rubble. The wall also transitioned into more extensive and gentler slopes with a silty appearance. These gentle slopes were mostly barren with only a sparse epifaunal abundance. During the dive, *Isis* returned to the thalweg to transect another flank of the canyon.

The second flank was similar to the first. The base of the slope was littered with broken, loose rock and large boulders that had fallen from the vertical face above (i.e. mass wasting). The mudstone / stiff clay vertical surfaces were mostly devoid of epifaunal assemblages. Occasional ledges with silt and broken rock intersected the wall. A gentle slope started at 1035 m before transitioning to a rippled surface near a water depth of 925 m. A distinct patch of coral rubble appeared at 895m before the presence of several substantial cold-water coral stands (with live framework). The urchin *Cidaris cidaris* was abundant on and within the coral colonies. After the coral (about 885 m), the silted mudstone / stiff clay plain resumed; this surface was often heavily burrowed by cerianthid anemones. Towards the end of the dive, and at a depth of 845 m, a large and dense cold-water coral reef was observed (pink colour morph; specimens collected).

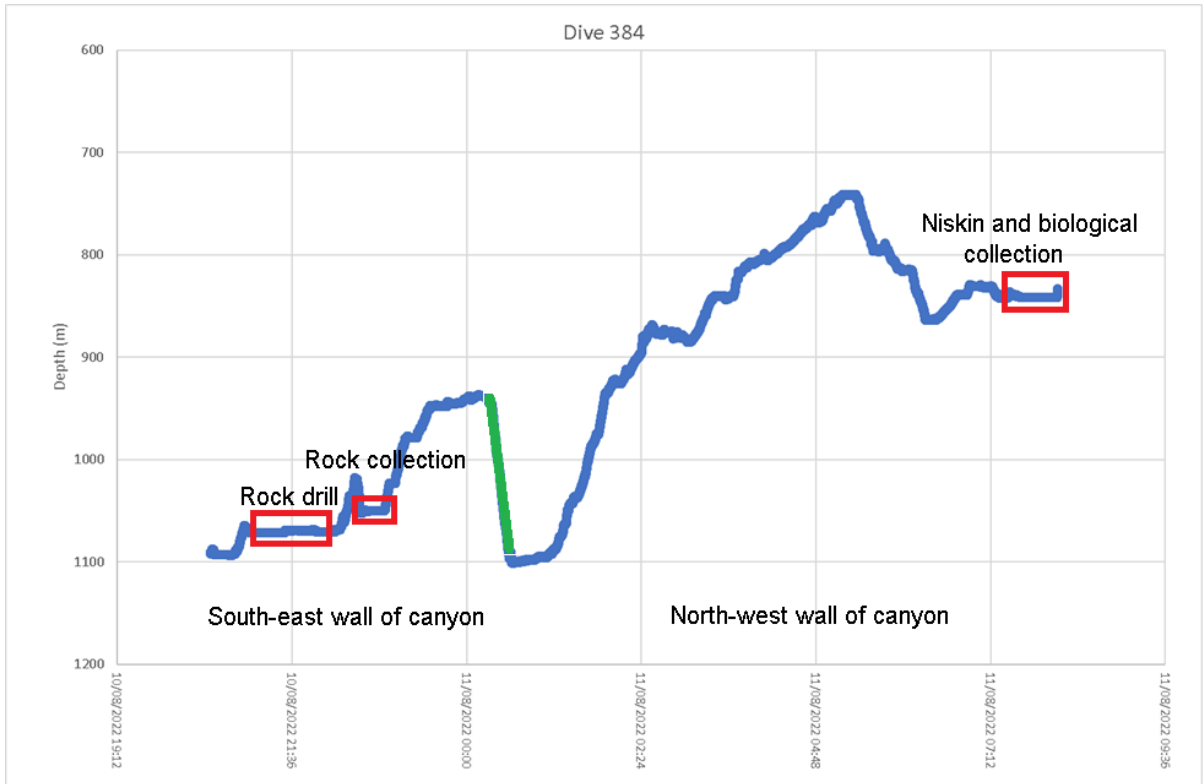
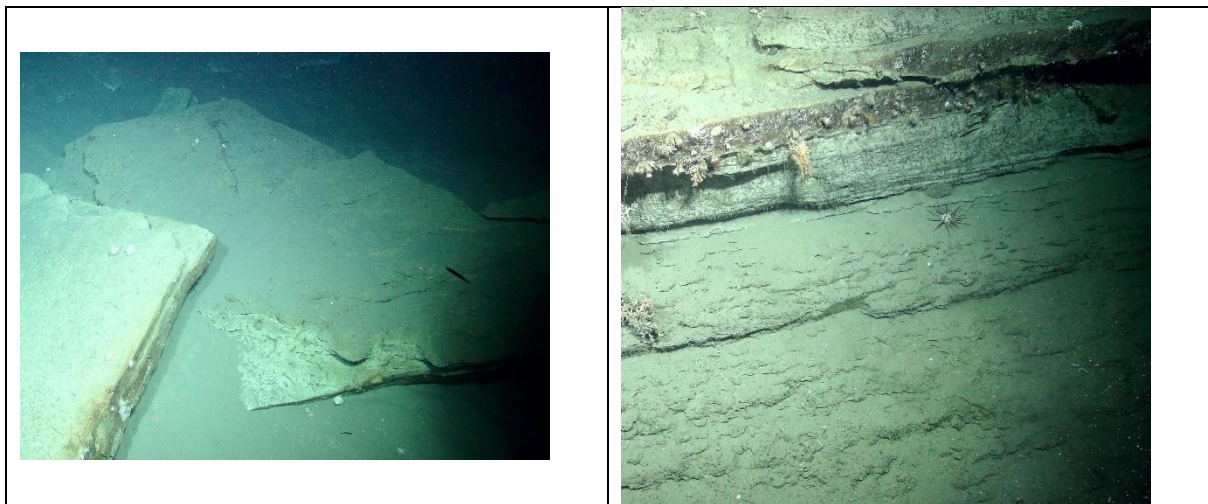

Fig. 6.37 Depth profile against time for ISIS ROV Dive 384, annotated with sampling events (red boxes) and mid-water transits (green track).



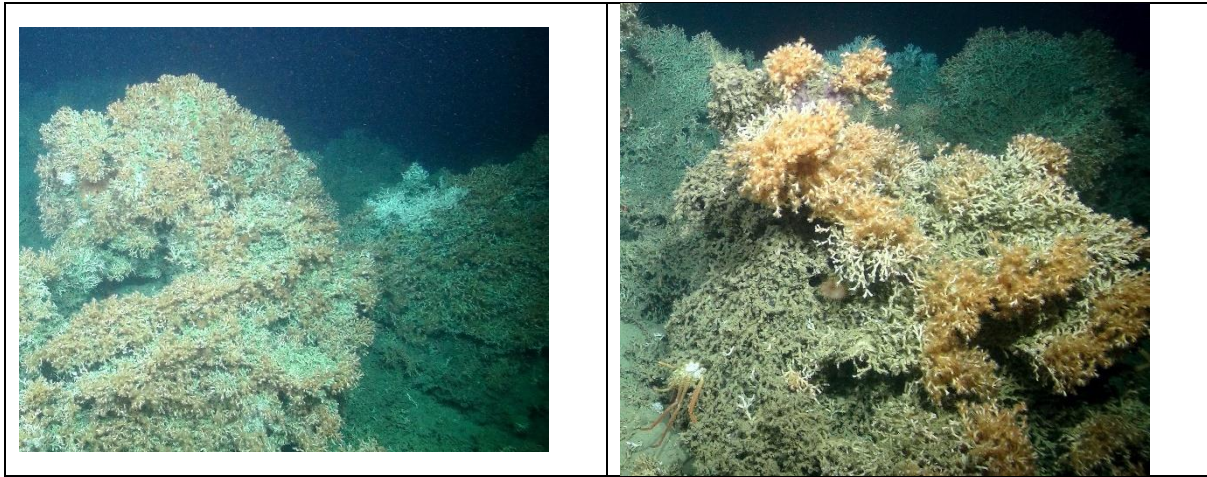

Fig. 6.38 Rock slabs and wall observed at the start of Dive 384 (top row) and CWC growth observed at end of dive (bottom row).

ISIS Dive 385

Poor visibility within the last 140-150 m of the water column prevented access to the thalweg and lower vertical walls. Following a midwater move, *Isis* cleared the worst of the turbid water at approximately 1270 m depth. The seabed at this point was a sedimented, gentle slope, with an abundance of xenophyophores. This slope was occasionally intersected by short, vertical surfaces (e.g. a mudstone / soft rock wall at 1223 m) before the gentle slope continued with xenophyophores (specimen collected). Following a midwater transit to another slope, the seabed was found to be similar to the first with a gently sloping surface covered with a thin veneer of mud (e.g. 1121 m on the second flank).

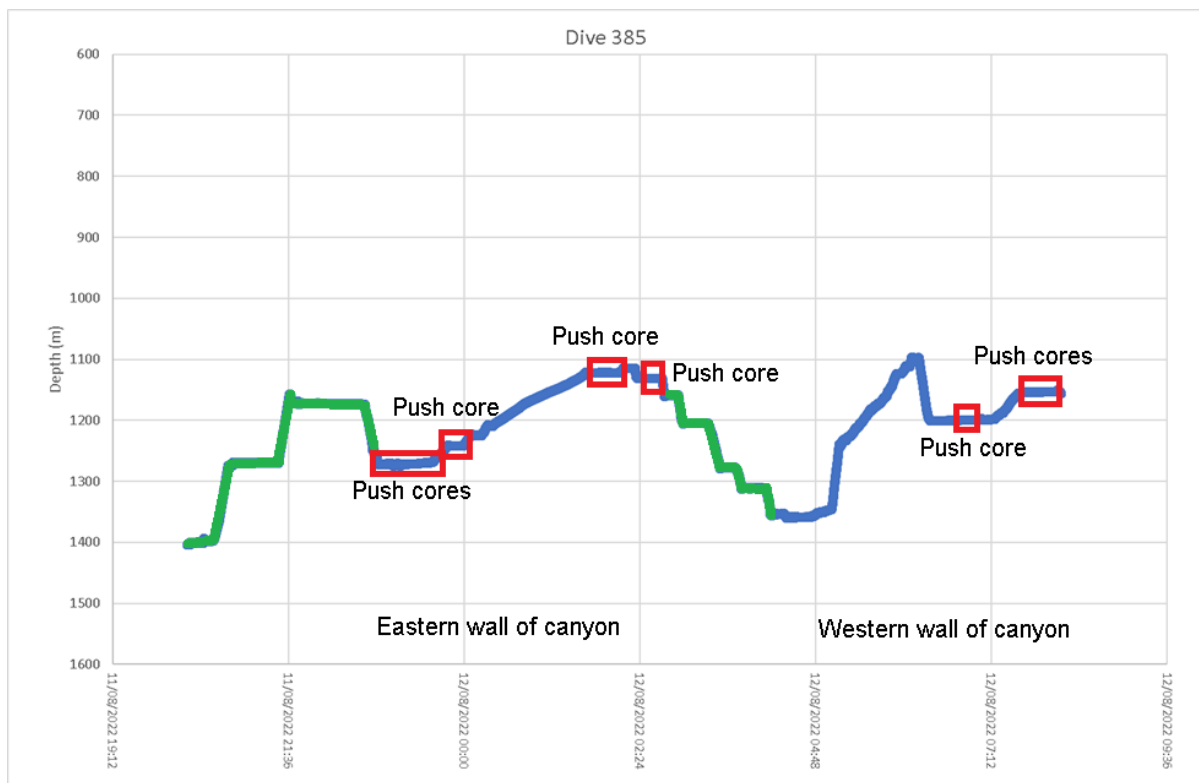

Fig. 6.39 Depth profile against time for ISIS ROV Dive 385, annotated with sampling events (red boxes) and mid-water transits (green track).

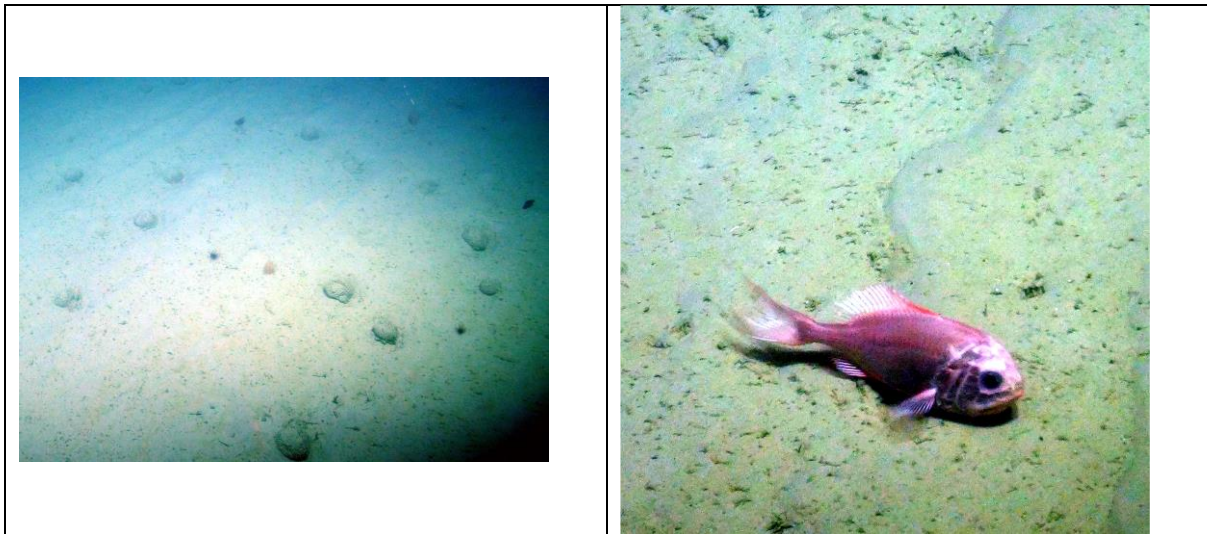

Fig. 6.40 Example photographs from Dive 385: Xenophyophore aggregation (? *Syringammina*), left and Orange Roughy, right.

ISIS Dive 386

The seabed at the start waypoint (~1366 m) consisted of a rippled, soft rock / stiff clay surface with occasional blocks of rafted rock and white rock (calcarenite) outcrops. Steeper surfaces started at a water depth of 1345 m; these were typically comprised of a broken, crumbly rock surface. At 1215 m, the soft rock surface remained near vertical but took on a smoother appearance and had many overhangs. The vertical surface eventually transitioned to a steep, smooth, sedimented surface typically of large areas of the canyons (at about 1185 m). Occasionally, the sediment surface was rippled (aligned, asymmetrical) but it remained a thin veneer over the soft rock surface. Heavily sedimented ledges were frequently found along the slope, with occasional soft coral / octocoral colonisation. At a water depth of 1150 m (03:35), a more substantial, hard rock (friable calcarenite rock) occurred with many overhangs with more hard and soft coral. This was followed (1115 m) by the smooth, sedimented slope again; these areas were associated with an occasional density of *Acanella* sp.

At approximately 1075 m, the slope transitioned to fine, soft sediment with distinct surface ripples; *Acanella* sp., tulip sponges (*Hyalonema apertum*), and occasional seapens (*Kophoblemnon stelliferum*) were abundant. At 1000 m, xenophyophores appeared and the sediment rippling stopped. Above this, (~915 m), cerianthid burrows appeared on steep / near vertical soft rock surfaces. At 750 m, the still steep, sedimented slope supported larger octocorals. A noteworthy event was the appearance of a short (~ 4 m high) vertical wall (685 m / 08:49) with dense oysters (*Neopycnodonte* sp.), solitary *Desmophyllum dianthus* and brachiopods on the overhanging surfaces.

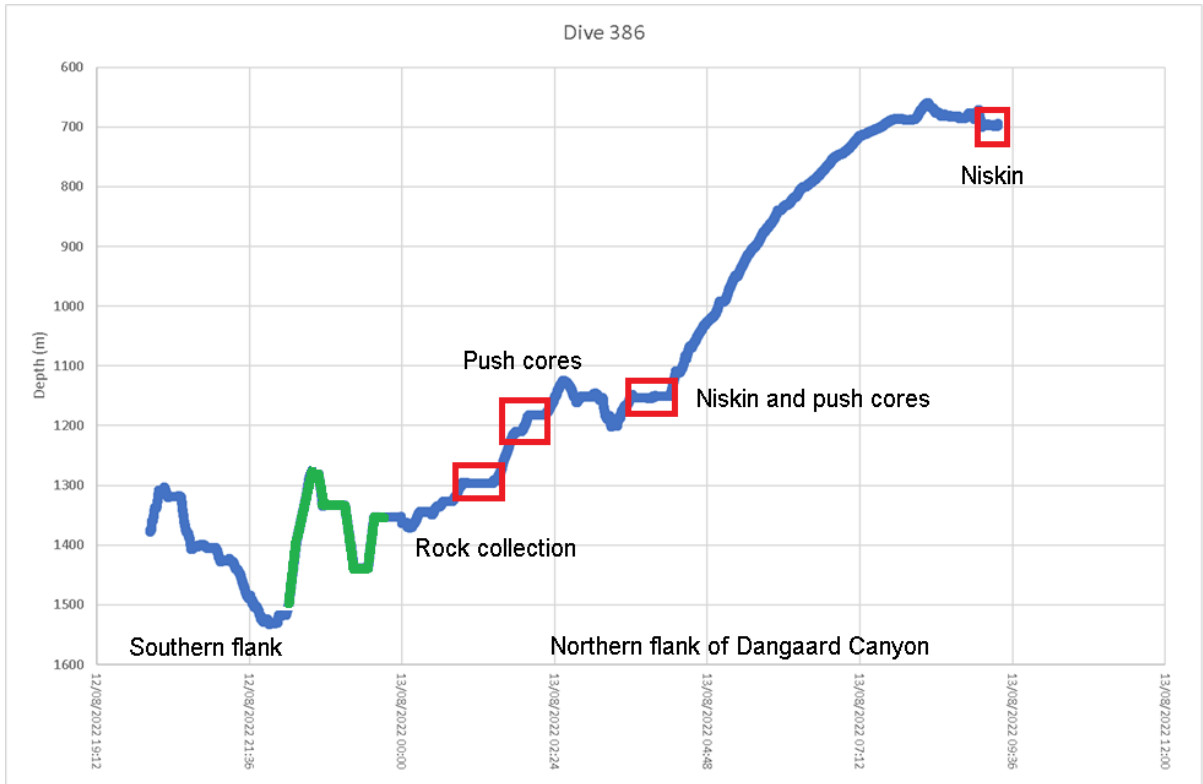
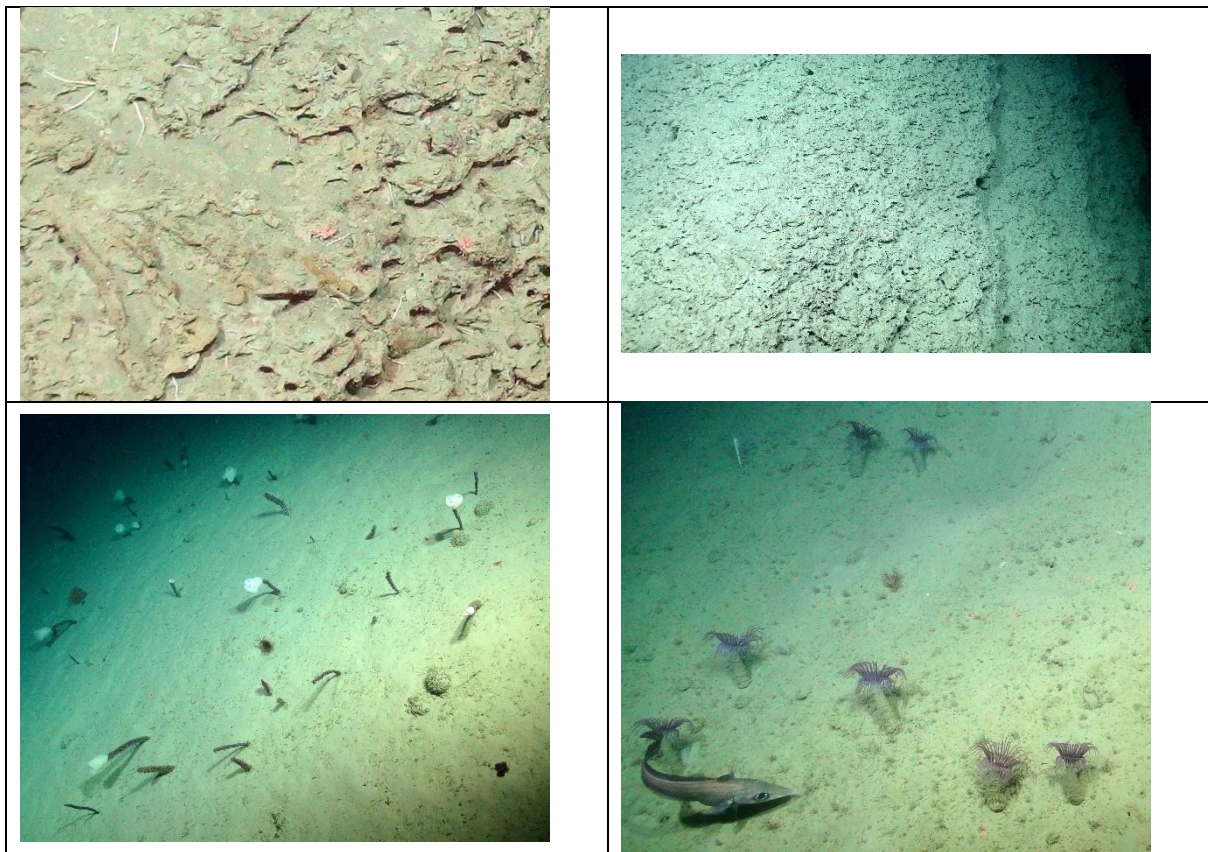

Fig. 6.41 Depth profile against time for ISIS ROV Dive 386, annotated with sampling events (red boxes) and mid-water transits (green track).



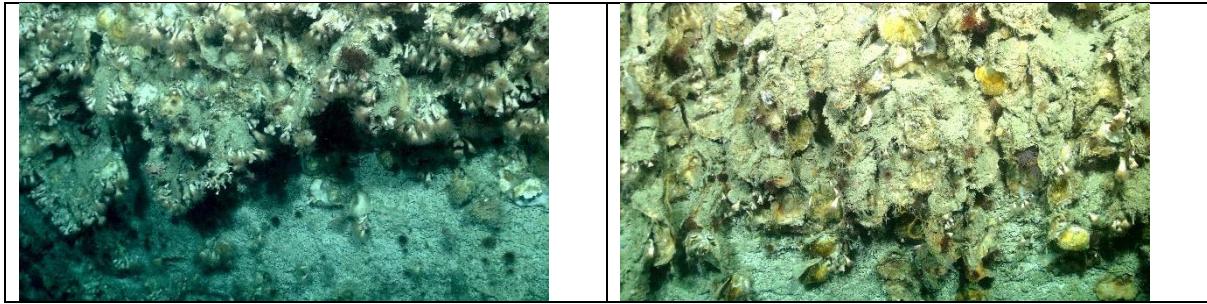

Fig. 6.42 Example photographs of Dive 386: Extensively burrowed 'soft rock' early in the dive (top row), glass sponge and cerianthid anemone aggregations on steeply sloping sediment (middle row), dense encrusting solitary corals and oysters towards end of dive.

ISIS Dive 387

The substratum at the start of the dive, within the thalweg, was a firm, irregularly rippled seabed with shell hash in ripple troughs: material was rapidly lost from push cores after being retracted from the seabed suggesting a fairly sandy substratum. The base of the canyon's flank was covered in a dense topping of coral rubble (~730 m). Above this, a white rock wall began with occasional cerianthid anemones burrowed into the surface. The vertical surface was interrupted by many small ledges with rippled sediment. As *Isis* ascended the wall, dense bands of oysters (*Neopycnodonte* sp.), fire clams (*Acesta* sp.), cold-water hard corals, and soft corals (e.g. *Acanella* sp.) appeared frequent. Eventually the wall transitioned to a steep, but not vertical, sediment plain with many burrows (cerianthid anemones) and faint rippling: this continued to a water depth of 541 m. *Isis* then returned to the thalweg to conduct another transect. This flank was similar to the first. This wall also had high densities of *Acanella* sp. and cold-water corals on the wall (especially at 576 m).

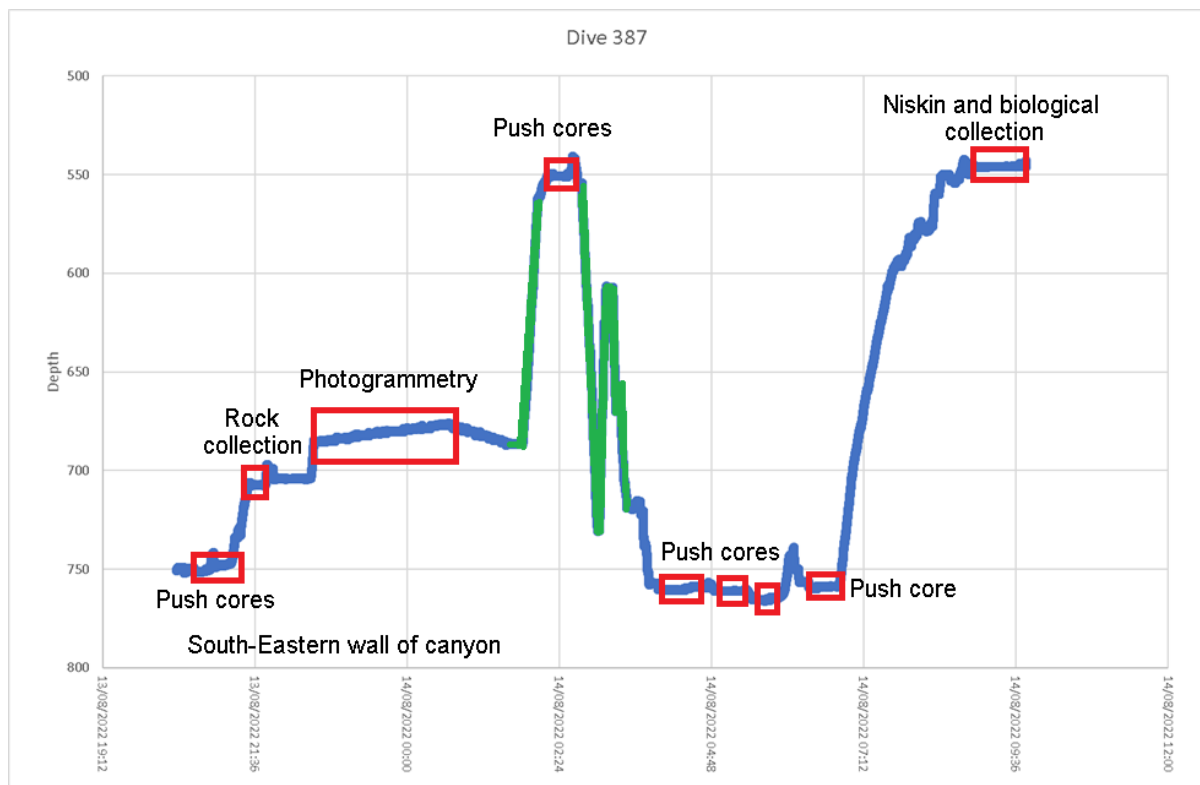

Fig. 6.43 Depth profile against time for ISIS ROV Dive 387, annotated with sampling events (red boxes) and mid-water transits (green track)

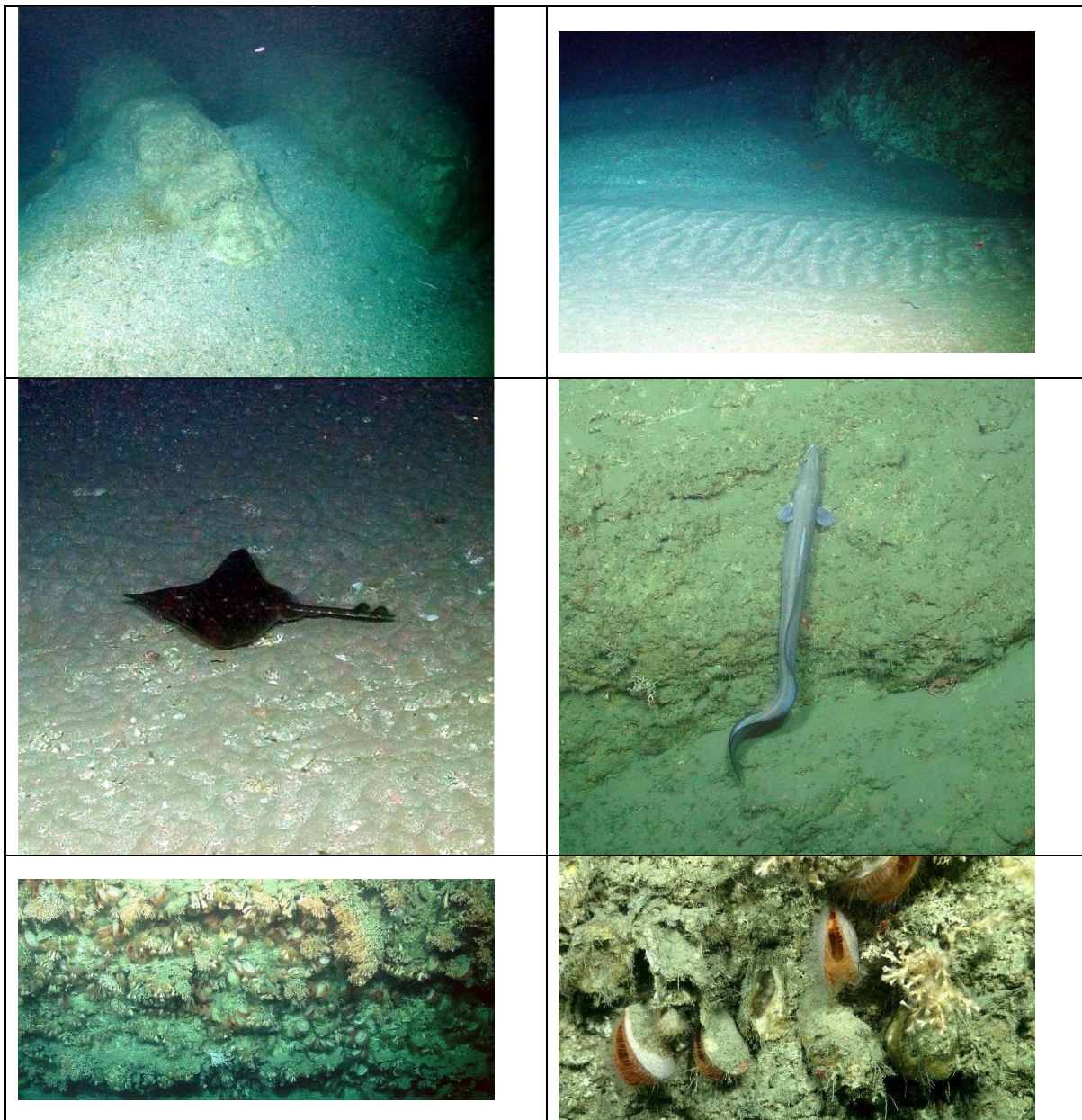

Fig. 6.44 Example photographs for Dive 387: Calcareous hash(?shell and coral) early in the dive (top row), large skate and conger eel (middle row), dense Acreta clams and CWCs

ISIS Dive 388

The seabed at the deepest section of the dive appeared to be a finely rippled, silty sand strewn with many large white boulders. The first section of the vertical wall began at a water depth of 1333 m. This surface was comprised of an angular rock surface with many overhangs. This rugged rock surface was occasionally interrupted by shallow ledges with gentle slope angles and accumulations of sediment. The vertical surfaces were colonised by a sparse epifaunal turf, including brachiopods, as well as hard and soft corals (at 1170 m, hard coral became more abundant). Towards the top of the wall, the seabed changed from a vertical surface to a gentler slope with dense coral rubble.

Isis then returned to the base of the canyon and conducted two more ascending transects. These were similar to the first with vertical surfaces provided by a hard, angular rock with several overhanging protrusions. The associated communities (hard and soft corals, sponges, and brachiopods) were often abundant and probably benefited from reduced siltation both on body surfaces and rock faces. Above water depths of ~1150 m, the walls transitioned to gentler slopes accompanied with an abundance of xenophyophores, small brachiopods, and cerianthid anemones.

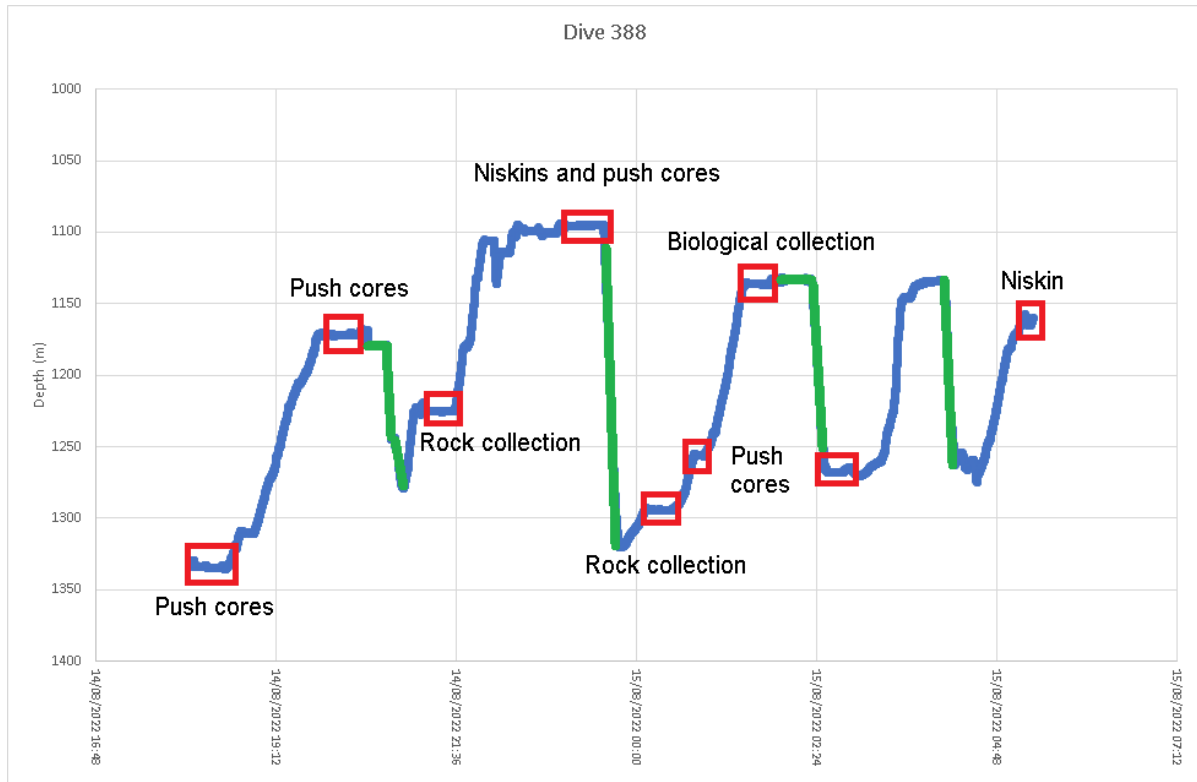

Fig. 6.45 Depth profile against time for *ISIS* ROV Dive 388, annotated with sampling events (red boxes) and mid-water transits (green track).





Fig. 6.46 Examples of photographs from Dive 388: Well developed, diverse coral communities, stalked crinoid, orange roughy on sedimented seabed, and xenophyophore aggregation.

ISIS Dive 389

Starting within the thalweg, the seabed had a distinct sawtooth profile due to the bedforms with a scattering of white boulders. The sediment surface had a lingooid, irregular rippling evident on top of the bedforms. The crests of the bedforms were associated with coarse, sorted material. The slope rising from the thalweg was interrupted by several heavily sedimented ledges. Gouging with the ROV's manipulator arm suggested that the slope was a stiff clay / soft mudstone. These surfaces were mostly colonised by large, white brachiopods and globular white sponges. As *Isis* ascended, the vertical surface occasionally gave way to smoother slopes covered in a thin veneer of sediment and little epifauna.

Isis returned to a depth of approximately 1300 m three more times to restart the video transects along different flanks. The terrain for these transects was similar to the first with an initial vertical surface, colonised by brachiopods, sponges, and large anemones on hard rock edges and under overhangs. The vertical surfaces eventually transitioned to a gentler, smoother sediment surface after about 100 – 150 m above the thalweg.

The last transect progressed into shallower waters. This area was characterised by rippled sediment with occasional pieces of broken mudstone/dense clay and three to four short wall sections. At a water depth of 985 m (04:56 am), the sediment had more fauna (urchins and sea pens) and a shallower slope; this continued to 797 m before *Isis* left the seabed.

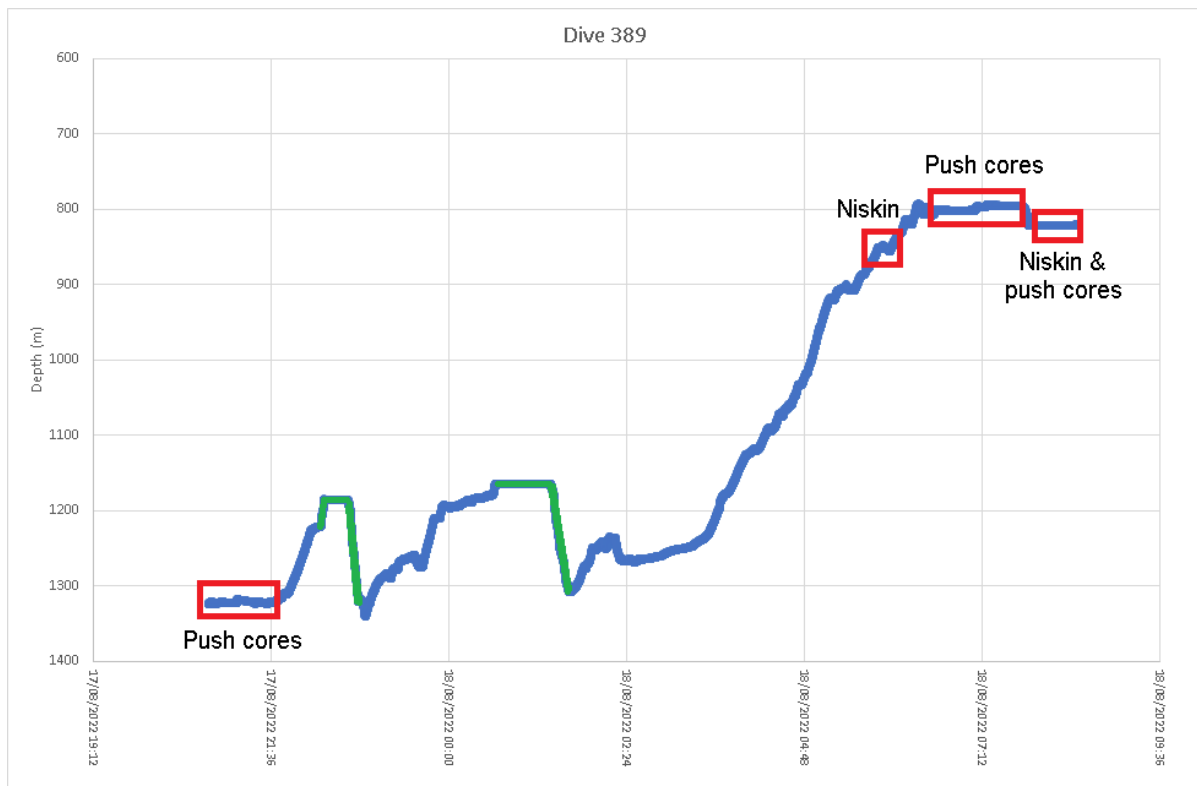
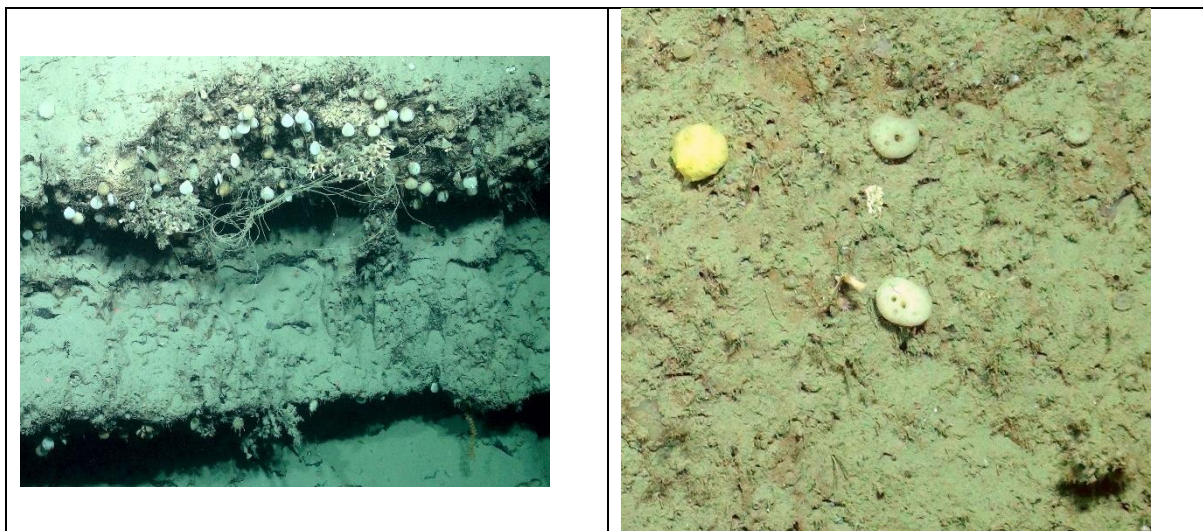

Fig. 6.47 Depth profile against time for ISIS ROV Dive 389, annotated with sampling events (red boxes) and mid-water transits (green track).



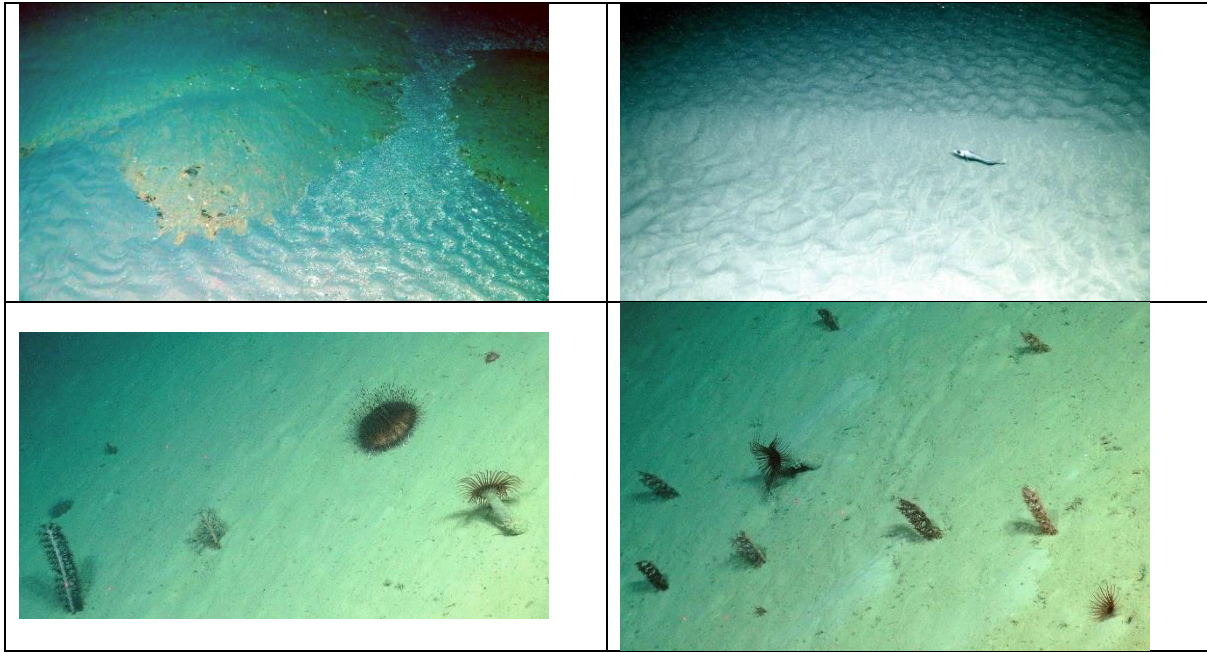

Fig. 6.48 Example photographs from Dive 389: Brachiopods and sponges on hard surfaces (top row), sediment drifts and bedforms (middle row), sea pens and cerianthids on steeply sloping sediments (bottom row)

ISIS Dive 390

Isis reached the bottom of the thalweg in 1880 m of water. The seabed appeared to be a firm sediment with an irregular, lingoid, rippled surface. The edges of the channel had large concentrations of broken rock and cobble, probably lost from the vertical slopes above. The seabed changed abruptly to a vertical, rugged rock surface, although it was mostly devoid of epifauna except for some polychaete tubes. Interestingly, the rock transitioned to darker material at a water depth of 1666 m: the change in colouration may be the result of diagenetic processes locally. The wall was occasionally interrupted by steep sloping sediment surfaces that appeared to form several sharp ridges. At 1595 m, a stratified rock wall started: epifaunal species were attached to harder edges and included hard corals, soft corals, sponges, bamboo corals, brachiopods, *Anthomastus* sp., etc. At 1400 m, the slope angle decreased and the substratum that followed was dominated by xenophyophores, which increased in number to the shallowest point of the dive at 1300 m.

Returning to a slightly deeper section of the thalweg (1953 m), the seabed was again characterised by an irregular rippled sediment surface. Near the base of the wall, massive boulders and rafted blocks were apparent. At a water depth of 1945 m, the wall started with a dark, irregular rock surface with many overhangs with sparse epifauna. The wall was occasionally broken up with shallow ledges with highly rippled sediment with mixed boulders and broken soft mudstone / stiff clay. Interestingly, some of the steep surfaces had asymmetrical ripples imposed on them, suggesting strong water motion across the soft, erodible rock face. The overhangs were colonised by *Anthomastus* sp. and other octocorals with occasional *D. dianthus*. At 1655 m, the wall became more terraced and the exposed rock layer edges had a sparse epifaunal assemblage; again, overhangs had dense *D. pertusum*, solitary hard corals, large brachiopods, and soft corals. At a water depth of 1610 m, a dense field of white flabellate sponges appeared (specimen collected). Following this, the wall transitioned to a steep slope (near 1590 m), with a similar profile of epifaunal species as before.



Fig. 6.49 Depth profile against time for ISIS ROV Dive 390, annotated with sampling events (red boxes) and mid-water transits (green track)

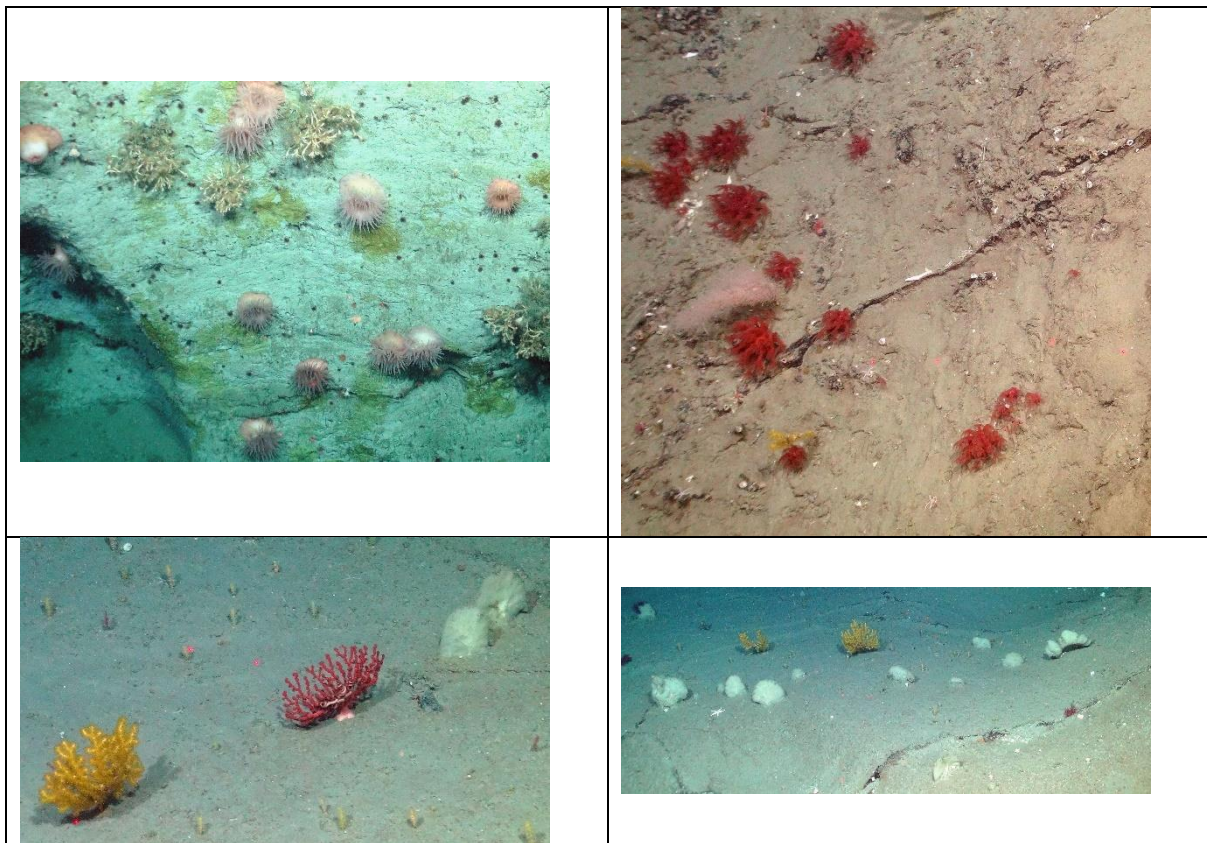



Fig. 6.50 Example photographs from Dive 390: Anemones and *Anthomastus* on steeper walls (top row), fan sponges and soft corals on gently sloped rock (middle row), soft coral and brisingid aggregations (bottom row)

ISIS Dive 391

As per dive 385, persistently high levels of turbidity in the bottom 100 m of the water column meant that the thalweg and steepest sections of the canyon walls could not be accessed. As such, *Isis* moved, mid-water, to higher sections of the canyon flanks. The seabed at 1360 m was a rippled (linear and symmetrical) soft sediment on a slope (approximately 45°). This surface was devoid of epifaunal species. This slope was interrupted by irregular rock ledges with a few *Acesta sp.* and brachiopods, before returning to a moderate slope with sediment veneer. *Isis* then relocated to the opposite flank, which was similar in appearance. Towards the end of the dive, the sloped seabed in shallower water (1260 – 1060 m) was associated with dense xenophyophores on a fine sediment surface.

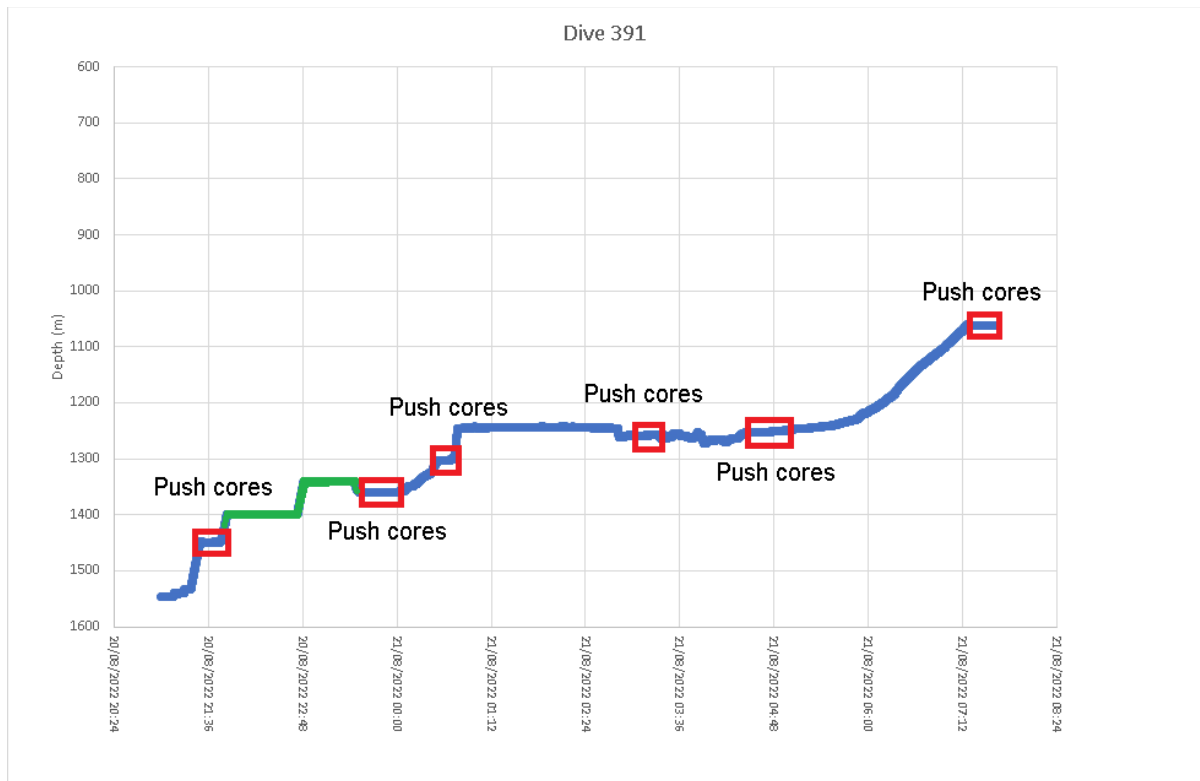

Fig. 6.51 Depth profile against time for ISIS ROV Dive 391, annotated with sampling events (red boxes) and mid-water transits (green track)

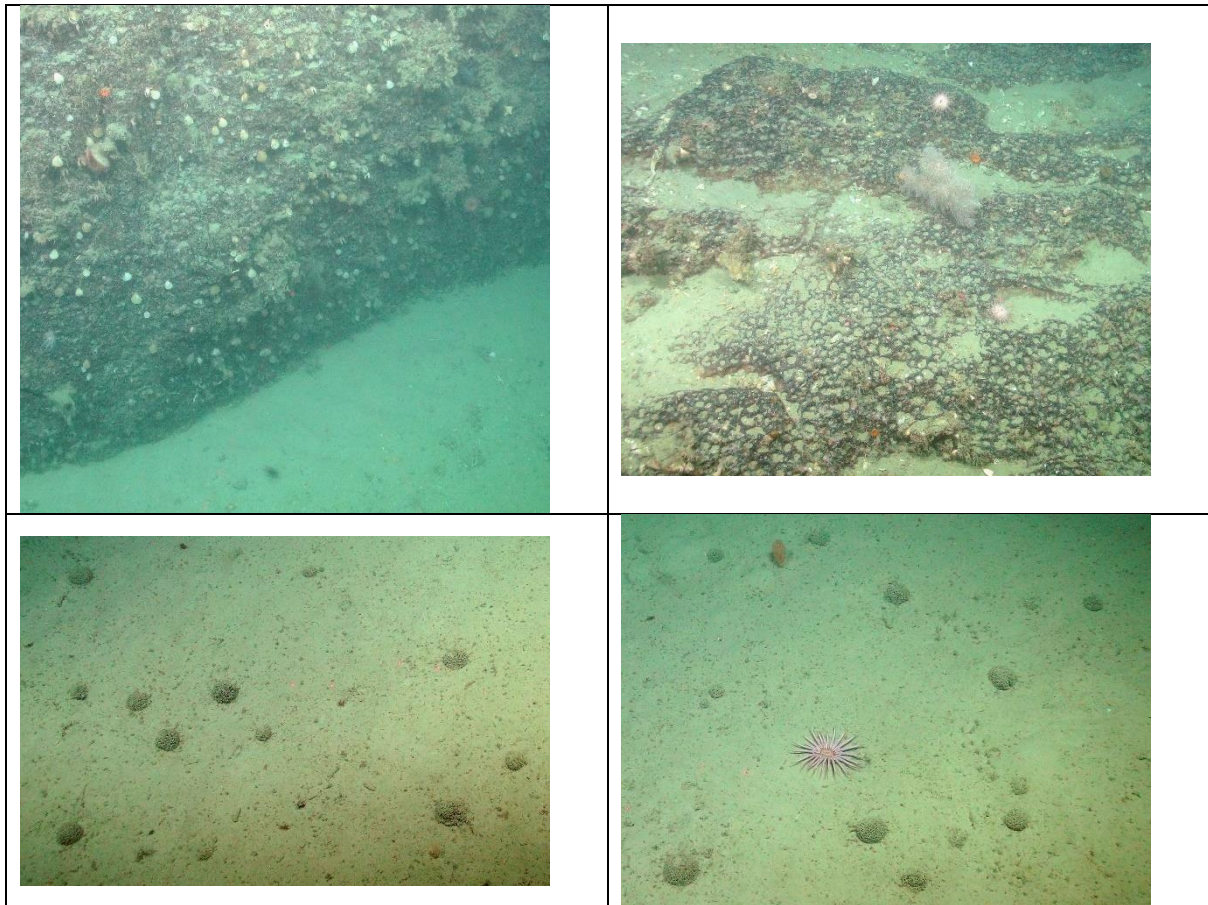

Fig. 6.52 Example photographs from Dive 391: Brachiopods and occasional *Acesta* on darkened rock (top row), xenophyophore aggregations on sloping sediments

ISIS Dive 392

This dive was dedicated to the retrieval of rock cores and loose rock samples. *Isis* landed on a hard rock plateau at a water depth of about 1589 m. This surface was then successfully drilled by the *Isis* rock drill. Following this, *Isis* roamed within the area seeking another plateau to drill in slightly deeper water. During this search, dense cold-water hard coral assemblages were seen under overhanging rocks (1657 m). Eventually, a rock platform was selected and drilled. The same site had many small, isolated *D. pertusm* and *M. oculata*. colonies on rock surfaces as well as an abundance of fan-shaped sponges. Unfortunately, the second drilled section got stuck in the drill, so further drilling was not possible. Following a midwater swim, *Isis* joined the seabed at the bottom of a rock wall (1915 m). The site was highly heterogenous (boulder-strewn rippled sediment). Harder surfaces were colonised by *Anthomastus* sp. Lost fishing gear (ropes and monofilament line) was abundant. At 1885 m water depth, the boulder debris disappeared leaving a long, gently sloping, rippled sediment plain with little to no epifauna.

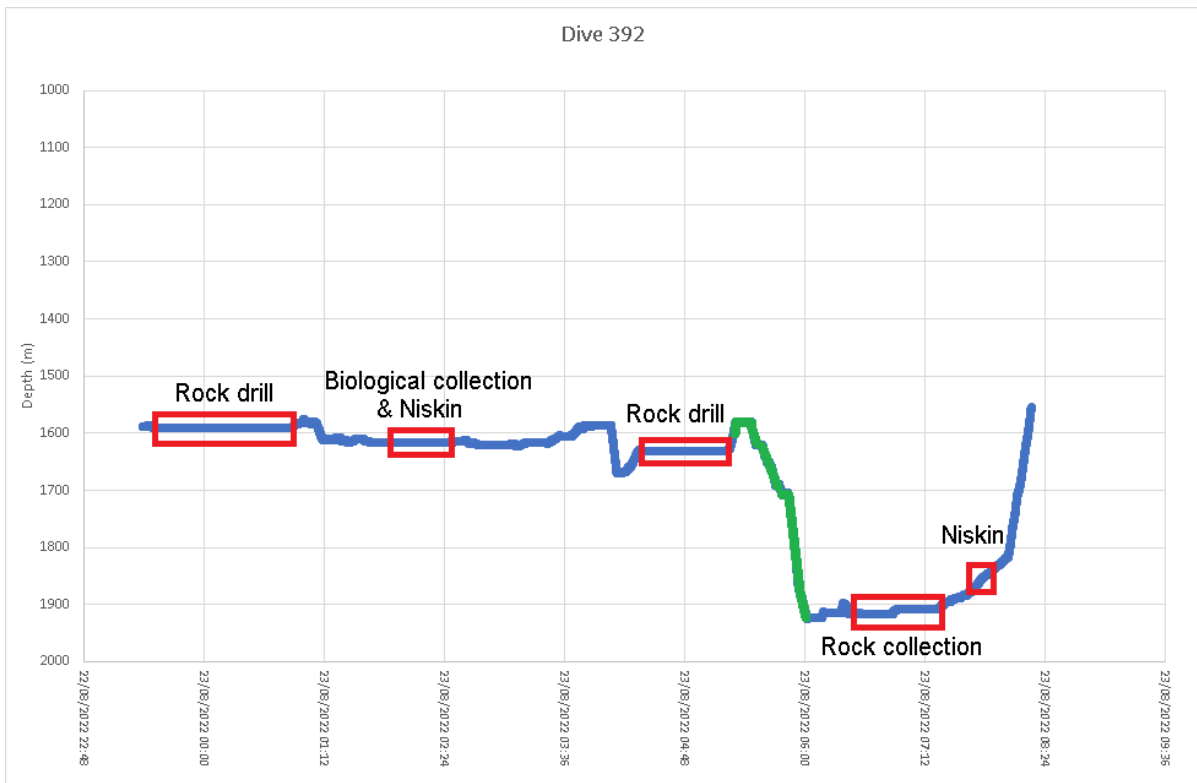

Fig. 6.53 Depth profile against time for ISIS ROV Dive 392, annotated with sampling events (red boxes) and mid-water transits (green track)

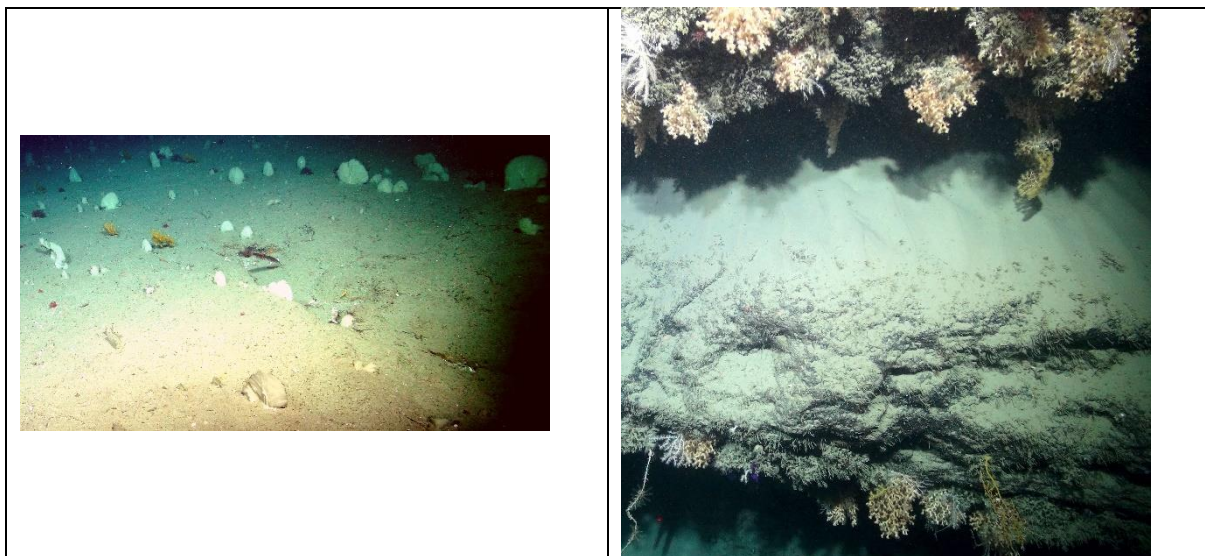

Fig. 6.54 Examples of photographs from Dive 392: Fan sponge (left) and CWC (right) aggregations

ISIS Dive 393

This dive was dedicated to the collection of forward-facing multibeam echosounder data of the vertical surfaces within the Aesta branch, with overlapping photogrammetry. The wall itself was fairly flat with a moderately high density of soft corals, such as *Acanella* sp., hard corals (small but numerous

colonies), and *Cidaris cidaris*. A figure detailing the dive profile has not been produced due to the limited vertical movement of the ROV during the MBES and photogrammetry surveys.

ISIS Dive 394

Following the descent of *Isis* to the seabed, the substratum was found to be a sedimented, smooth slope with no epifaunal species. The seabed had occasional patches of distinct white boulders; larger boulders had small but frequent cold-water hard coral colonies (~1084 m). The gently sloping seabed was interrupted by occasional small walls with moderate cold-water hard coral cover (e.g. at 1034 m and 936 m). Following this, the slope resumed (approx. 45° with rippled sediment). At depths between 653 m and 648 m, a discrete patch of rubbly black carbonate rock appeared; this was associated with much litter (especially longline monofilament). After this, the sedimented slope returned. Much of the surface was heavily burrowed, however, this diminished towards the end of the dive at ~473m.

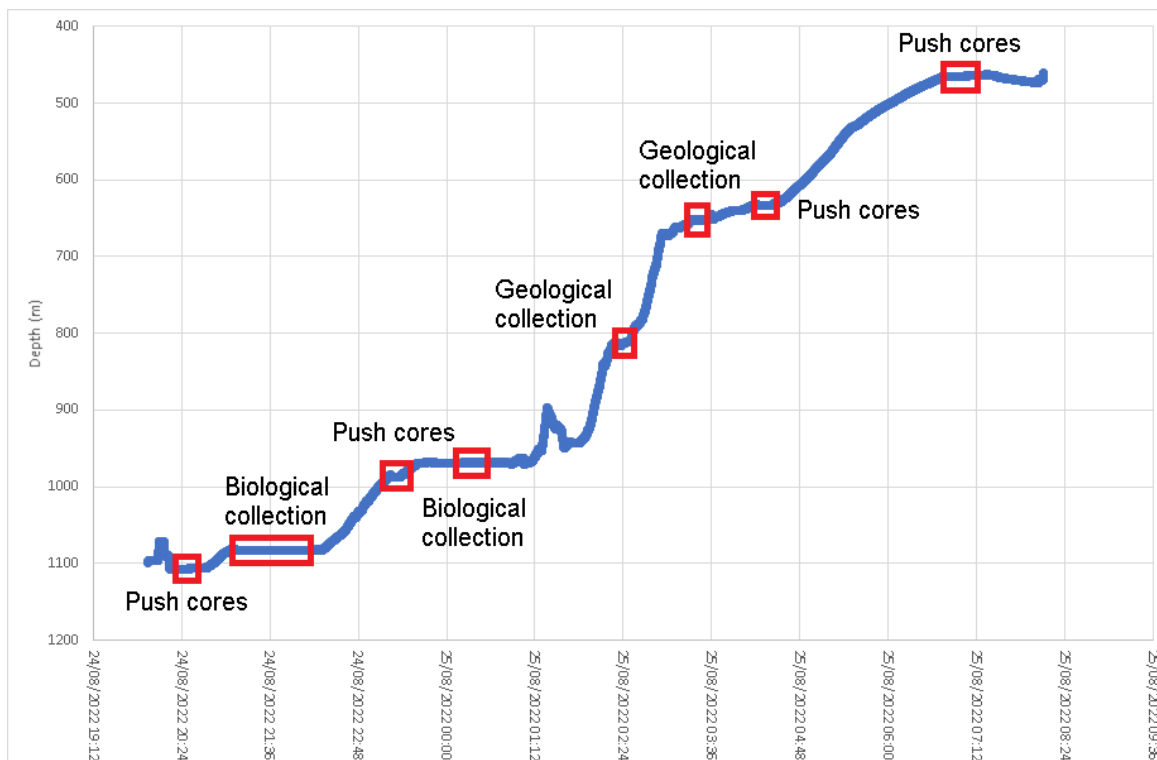

Fig. 6.55 Depth profile against time for ISIS ROV Dive 394 annotated with sampling events (red boxes) and mid-water transits (green track)

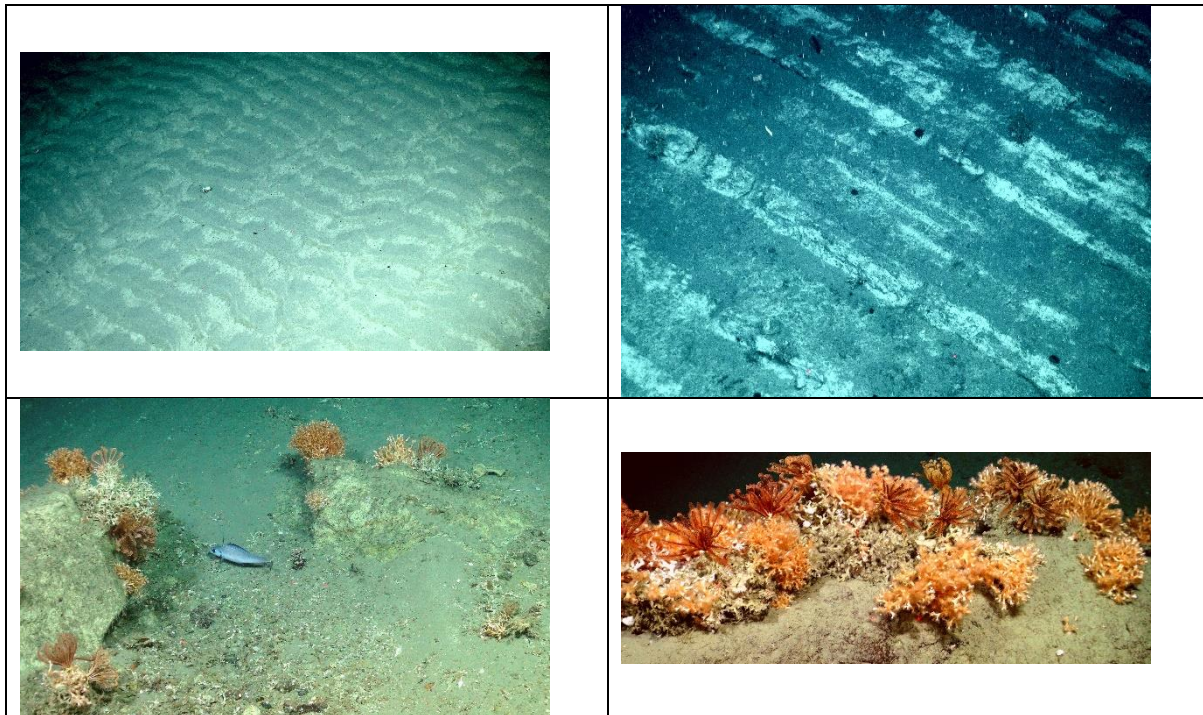

Fig. 6. 56 Examples of photographs from Dive 394: Varied seafloor terrain (top row), and CWC communities with abundant associated crinoids (bottom row)

ISIS Dives 395-397

These dives were undertaken in the Porcupine Abyssal Plain Sustained Observatory area and are covered in the corresponding section of this cruise report (section 6.2.2.3).

ISIS Dive 398

As soon as Isis arrived at the seabed, it was apparent that the site had a large abundance of small sea cucumbers (possibly *Peniagone* sp.). The cucumbers were concentrated into patches and ribbons across large areas of the seabed. Each patch contained hundreds to thousands of individuals. Large numbers of small sea cucumbers were also observed in the same location during JC010. It is possible that this site represents a significant dispositional zone within the eastern canyon and that high levels of organic matter are concentrated locally (feeding the substantial biomass present locally). The cucumbers appeared to differ in sexual condition; approximately one quarter were filled with an extensive network of ripe, white gonad and the remaining individuals were a transparent grey (having released gametes, or being a different sex or species). These spawning aggregations were abundant throughout start of the dive. The seabed supporting the cucumbers appeared to be a heavily sedimented substratum with small bedforms. Unlike areas higher up in the canyon, the turbidity at this site was low and current strength weak. Towards the deepest part of the thalweg, large bedforms were apparent with loose rock and bedrock outcropping within the escarpment demarcating thalweg. The thalweg transitioned from the bedforms to a gentle slope before changing again to a vertical surface. This wall was targeted for a photogrammetry survey. After the wall, the rest of the dive was dominated by a gently sloping surface covered with a thin veneer of sediment. This was mostly barren except for patches of soft corals, occasional anemones and stalked, predatory sponges.

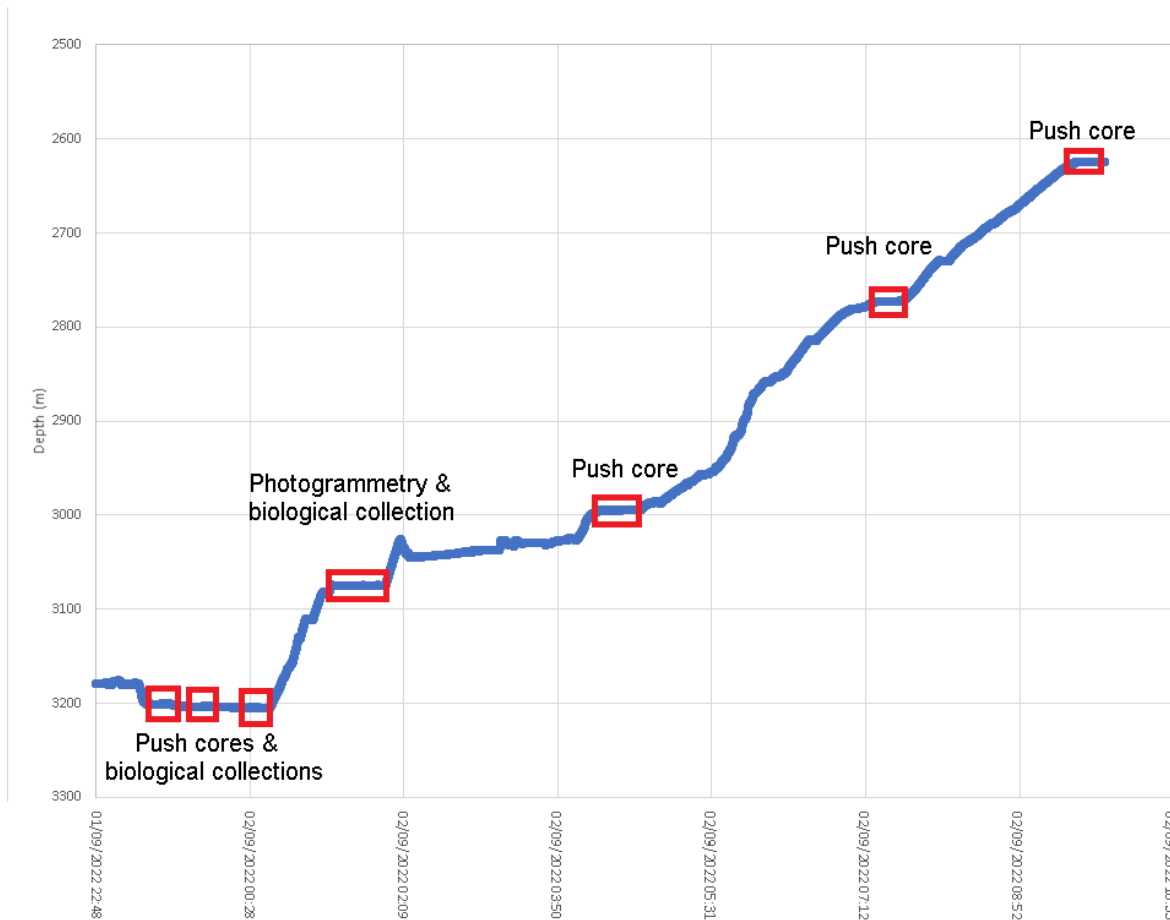

Fig. 6.57 Depth profile against time for ISIS ROV Dive 398, annotated with sampling events (red boxes) and mid-water transits (green track)



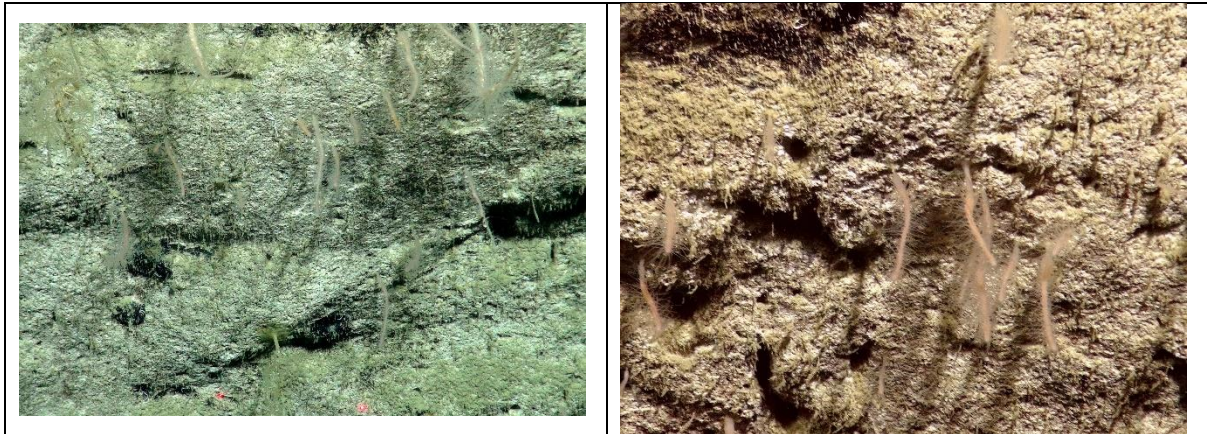

Fig. 6.58 Example photographs from Dive 398: Sea cucumber aggregations (top two rows) and potential predatory (cladorhizid) sponges (bottom row)



Fig. 6.59 Comparable sea cucumber (*Peniagone sp. 1.*) aggregation observations from Station M, c. 4000 m water depth in the NE Pacific. Adapted from figure 3 of Huffard et al. (2016)

6.2.2. Autosub5-based photography (Brian Bett)

6.2.2.1. AUV Camera setup

For Autosub5 operations during JC237 the vehicle was fitted with a single downward facing camera that was used with two inclined 10 J xenon discharge tube NOC-designed flashguns. The camera was a Point Gray Research Inc. (now, Teledyne FLIR LLC) Grasshopper2 camera, with 2/3-inch sensor (2448 × 2048 pixels). A 12 mm focal length lens was used, giving horizontal and vertical acceptance angles of 28.7° and 24.3° in water. For reference, when operated from an altitude of 3 m, the seafloor area observed is 1.56 × 1.31 m (2.05 m²). Note that for full image scaling it is necessary to apply additional corrections accounting for vehicle pitch and roll, and for the ‘lever-arms’ between the camera and the attitude and altitude sensors etc.

Prior to RRS *James Cook* cruise 237, the camera and flash arrangement on Autosub5 was modified from its original design. During RRS *Discovery* cruise 152, the original close side-by-side arrangement of the vertically oriented camera and flash was found to be highly susceptible to image degradation from near-field particle optical backscatter. This was greatly improved by relocating that flashgun to the nose of the vehicle, the original location of the forward oblique camera. Post-DY152, the second flashgun, originally associated with the forward oblique camera, was co-orientated with the first flashgun in the nose of the vehicle to provide additional illumination for the seafloor area imaged by

the vertically oriented camera. These modifications enabled Autosub5 to collect high-quality seafloor images when within appropriate range of the seafloor c. ≤ 4 m.



Fig. 6.60 Examples of Autosub5 photography from shelf edge areas of the Whittard Canyon system. Top to bottom, left to right: Scampi, Blackmouth catshark, Gurnard, Megrim, Argentine, Blue whiting, Argentine, Lesser spotted dogfish, Rabbit fish, Litter, Forkbeard, Conger eel

6.2.2.2. AUV photographic surveys in the Whittard Canyon area

During the course of the JC237 Autosub5 photographic operations in shelf edge areas of the Whittard Canyon system, the number of useful seafloor images obtained was limited by difficulties in the vehicle maintaining an appropriate photographic altitude in undulating terrain, resulting in both periods of high altitude (>5 m) operation on cresting an undulation, and bottom contact with undulations resulting in the release of the drop weight and termination of the mission. Nevertheless, camera-flash performance and image quality and useability for both biological and geological interpretations was good when within appropriate range of the seafloor.

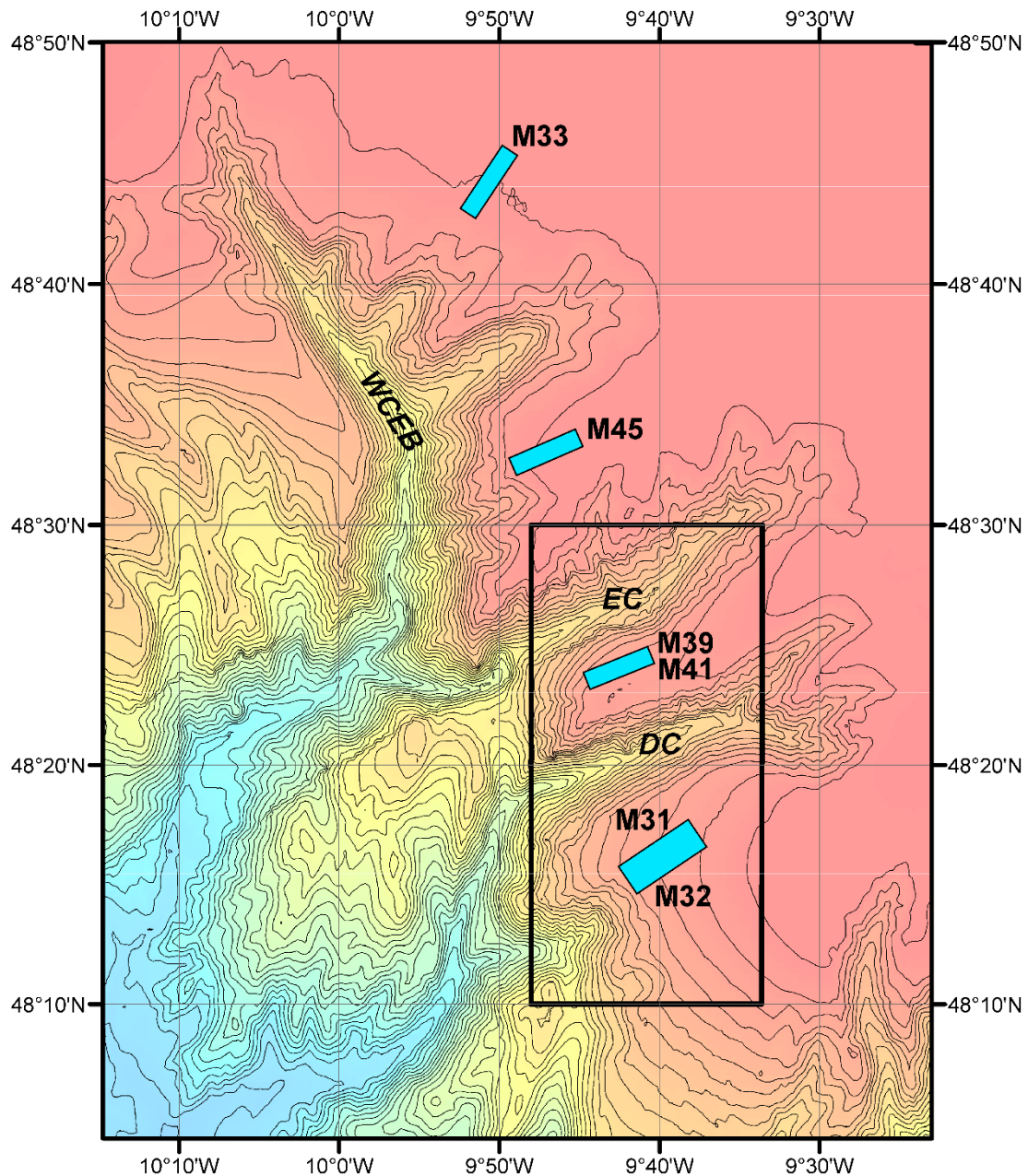

Fig. 6.61 Autosub5 photographic operations in shelf edge areas of the Whittard Canyon system, with The Canyons MCZ boundary indicated in heavy outline. Mxx, Autosub5 mission number; WCEB, Whittard Canyon Eastern Branch; EC, Explorer Canyon; DC, Dangaard Canyon. GEBCO 2022 bathymetry, 100 m interval isobaths from 200 m. World Mercator projection (WKID: 54004)

6.2.2.2.1 Missions 31 & 32 (JC237-03, 07), within The Canyons MCZ

Mission 31 returned a small number of useful seafloor images (c. 200) indicating the presence of drop stones and modest shoals of Boarfish. The mission ended with the vehicle contacting a mini-mound and in the process capturing images of highly fragmented cold-water corals.

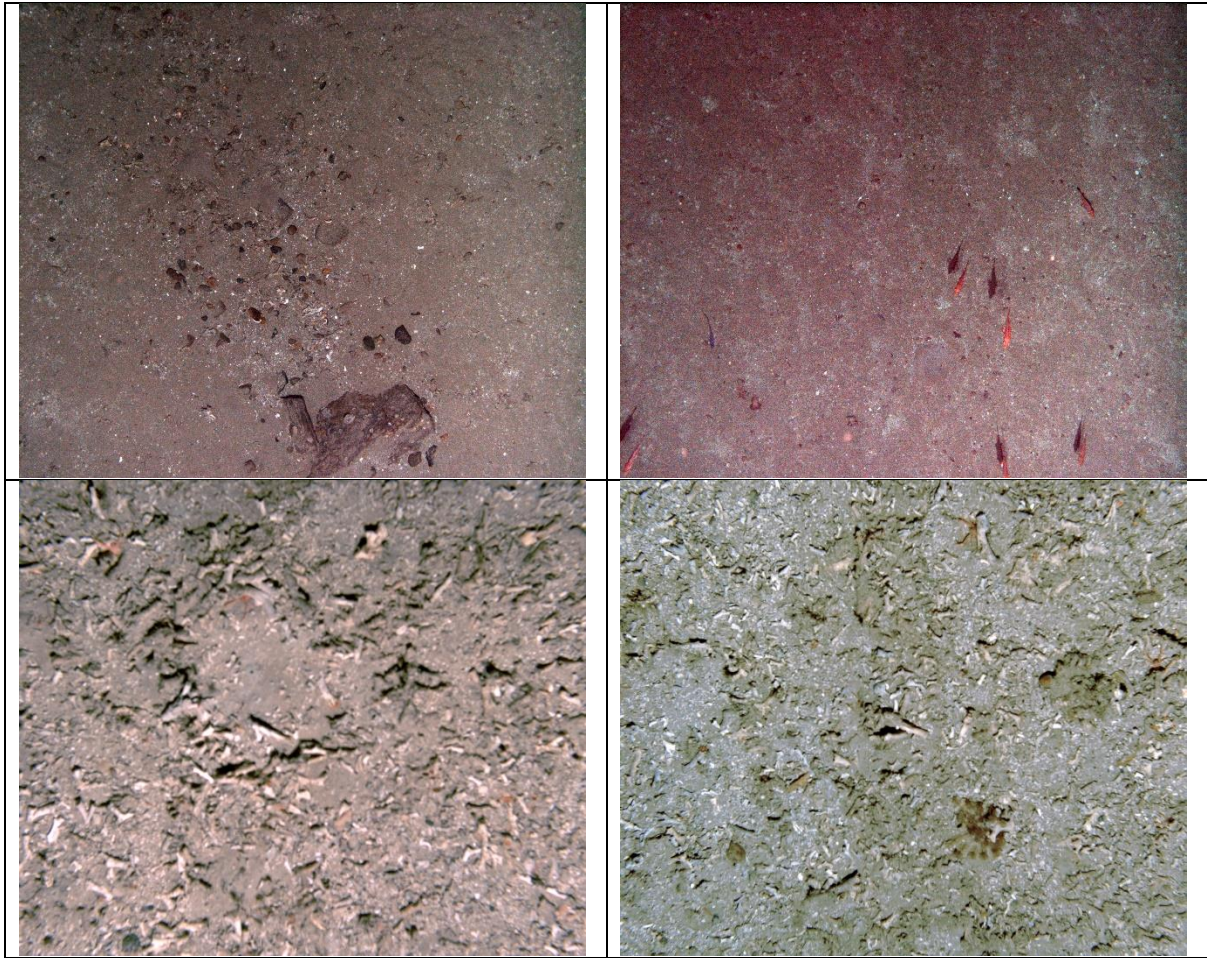

Fig. 6.62 Examples of Mission 31 (JC237-03) seafloor photographs

Mission 32 returned a large number of useful seafloor images (c. 6000) broadly representing three seafloor types: (a) strongly rippled sediments, (b) faintly rippled sediments, with more frequent observations of dropstones and burrow systems, and (c) cold-water coral 'mini-mound' terrain (as described in Stewart et al., 2014). Argentine were frequently observed over the strongly and faintly rippled sediments, with a more diverse fish fauna observed over the mini-mound terrain (modest shoals of Boarfish, Rattails, Rabbit fish).

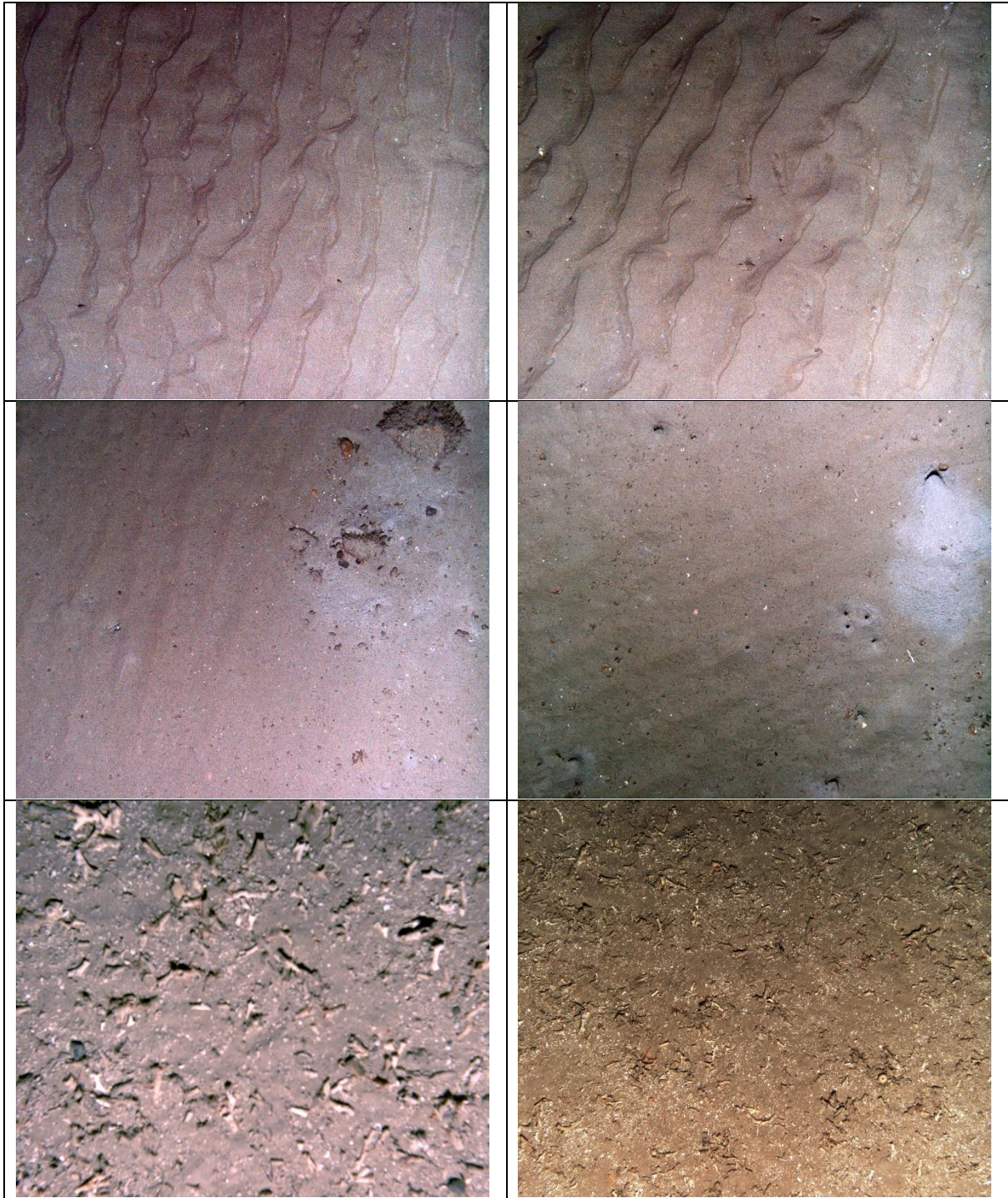

Fig. 6.63 Examples of Mission 32 (JC237-07) seafloor photographs

6.2.2.2.2 Mission 33 (JC237-10)

Mission 33 returned a modest number of useful seafloor images (c. 400). Seafloor type was broadly of a strongly rippled form, with occurrences of linguoid-type ripples. Boarfish aggregations were also observed.

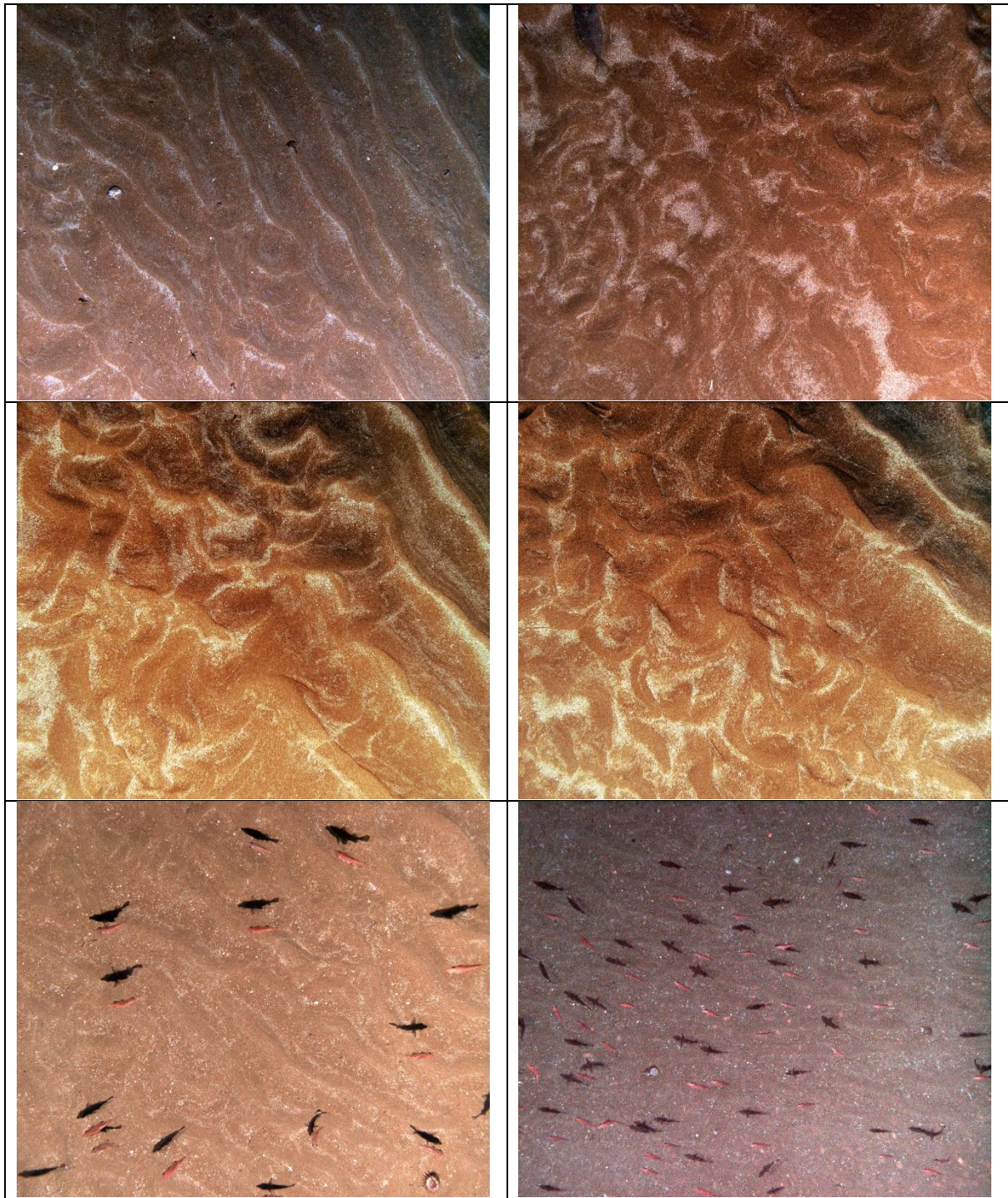

Fig. 6.64 Examples of Mission 33 (JC237-10) seafloor photographs

6.2.2.2.3 Mission 39 & 41 (JC237-37, 49), within The Canyons MCZ

Mission 39 returned a modest number of useful seafloor images (c. 500). Midwater, near-bottom, images from this mission illustrate a high concentration of particulate organic matter, with frequent observations of Argentine and Blue whiting. The available seafloor images indicate faintly rippled sediments, with frequent occurrence of dropstones, presumed calcium carbonate fragments of biological origin are apparent, but it is not clear that these represent fragmented cold-water corals.

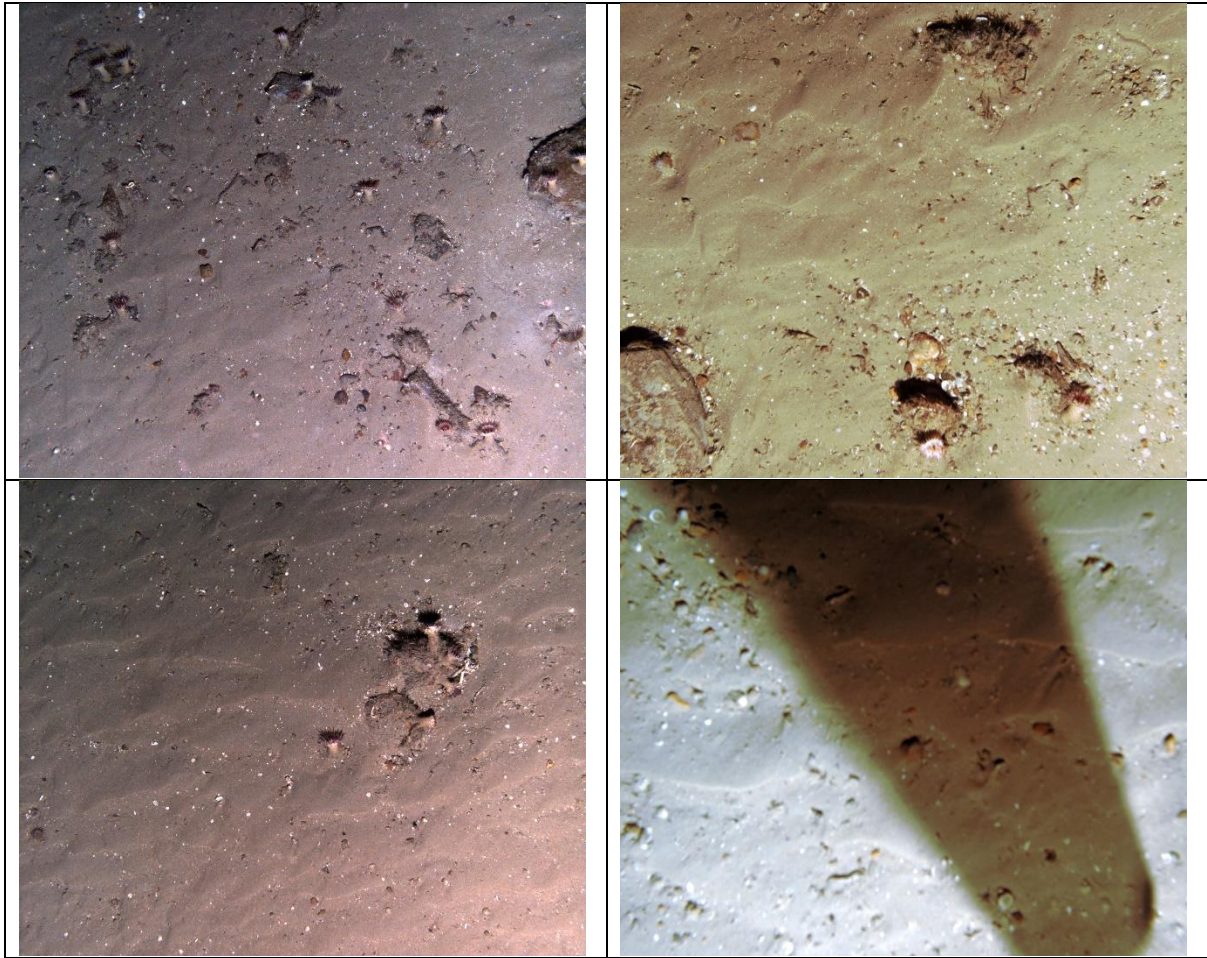
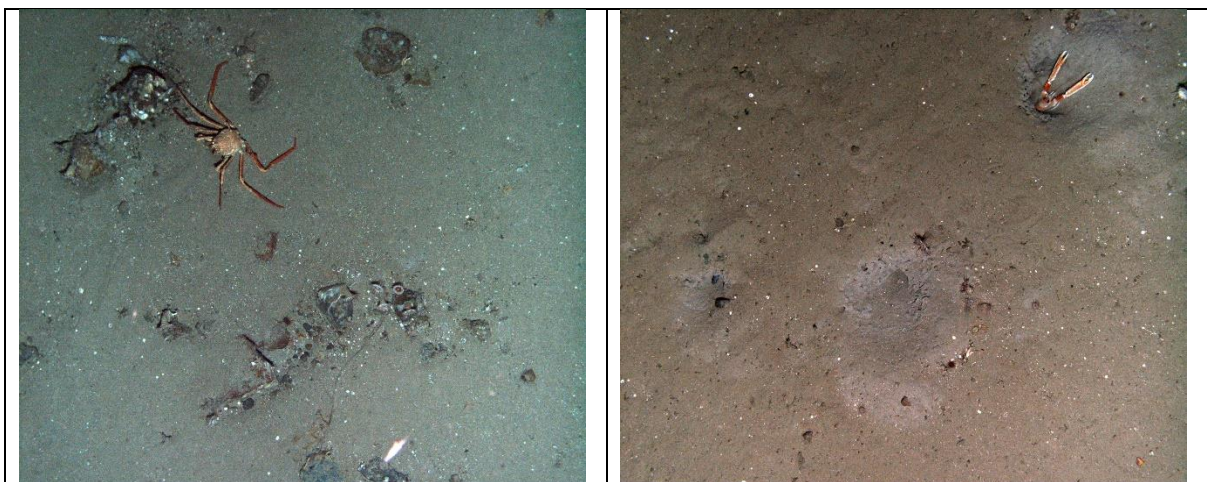

Fig. 6.65 Examples of Mission 39 (JC237-37) seafloor photographs. Lower left image captures shadow of drop weight at release

Mission 41 returned a relatively large number of useful seafloor images (c. 5000). The seafloor environment observed was generally of a 'smooth' fine sediment, with frequent observations of dropstones and large burrows. The mission terminated on bottom contact with a potential mini-mound that appeared to be marked by the presence of fragmented cold-water corals. A significant local aggregation of cidarid urchins was also observed during the course of the mission.



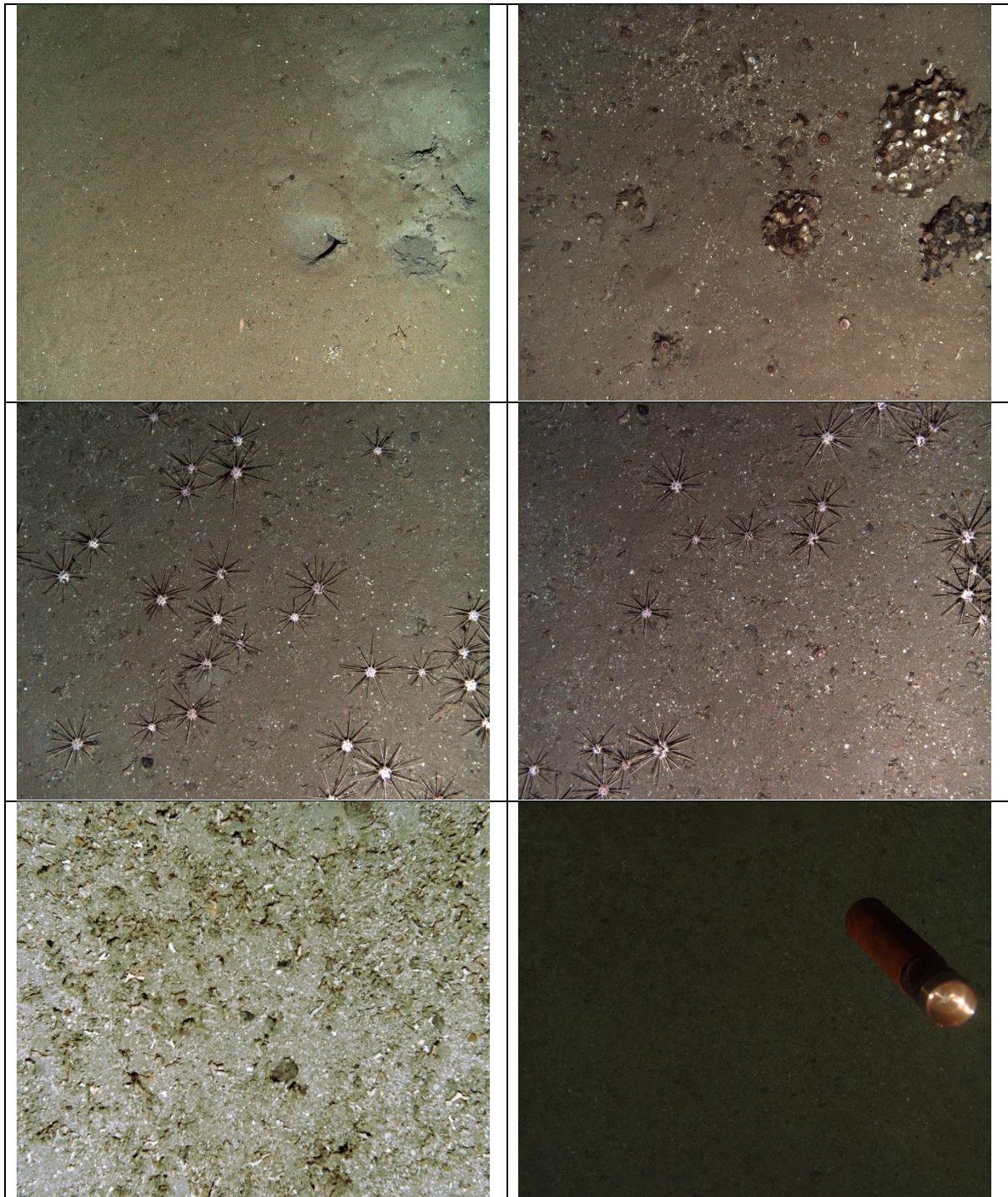

Fig. 6.66 Examples of Mission 41 (JC237-49) seafloor photographs. Lower left image captures drop weight at release

6.2.2.2.4 Mission 45 (JC237-66)

Mission 45 returned a relatively large number of useful seafloor images (c. 3000). Seafloor type, strongly rippled sediment, was broadly consistent throughout. Shoals of Boarfish, and aggregations of featherstars and brittlestars were also observed.

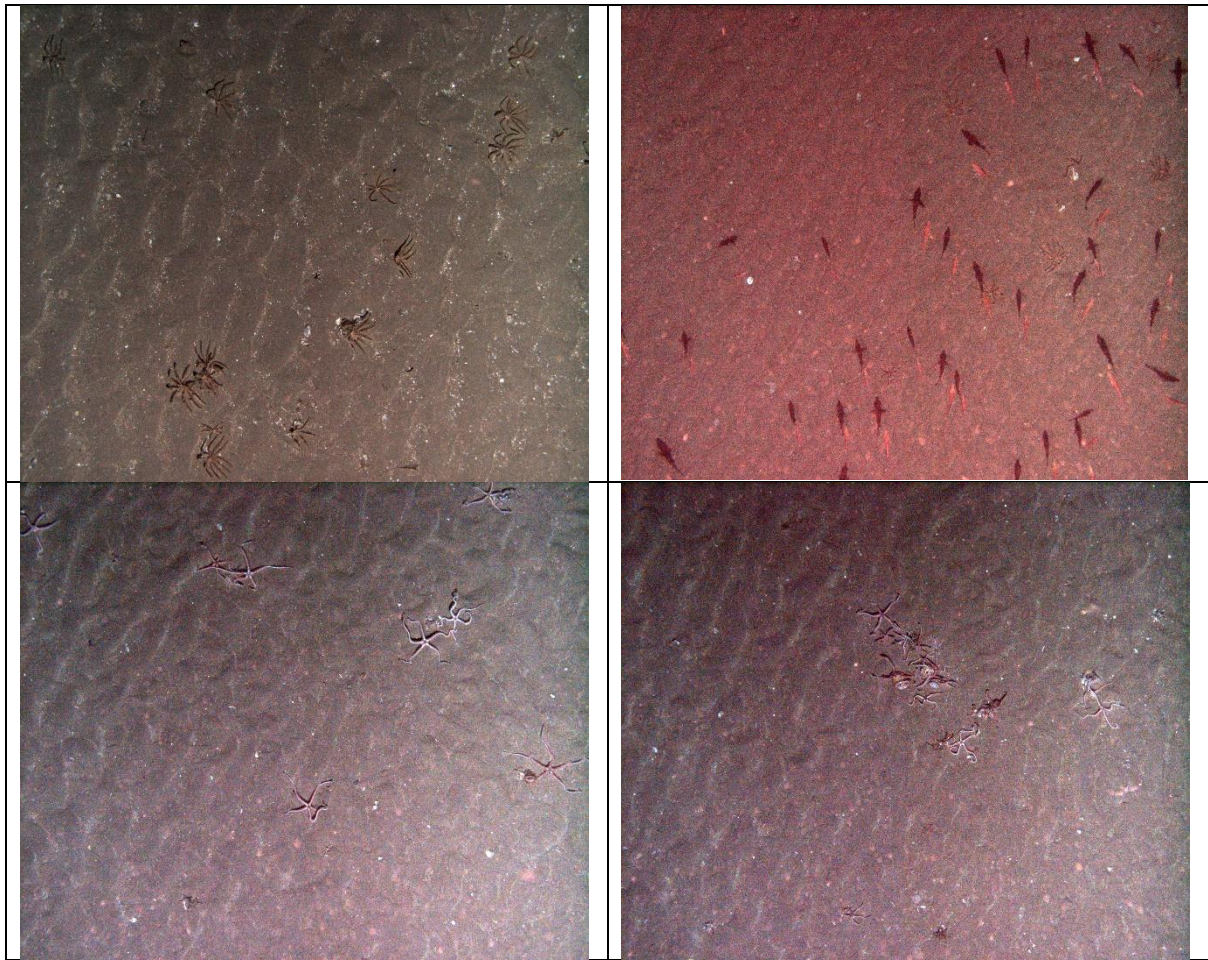

Fig. 6.67 Examples of Mission 45 (JC237-66) seafloor photographs

6.2.2.3. Photographic surveys in the Porcupine Abyssal Plain Sustained Observatory area

Photographic surveys of the seafloor in the Porcupine Abyssal Plain Sustained Observatory area were primarily carried out via two deployments of Autosub5 (M42, M43), with additional observations obtained during three deployments of the ROV *Isis* (dives 395, 396, 397). The first operations of Autosub5 and ROV *Isis* examined established areas of research with the PAP-SO referred to as the central, trawl, and moorings areas together with a small abyssal hill originally studied during the Autonomous Ecological Surveying of the Abyss (AESAs): Understanding Mesoscale Spatial Heterogeneity in the Deep Sea project (NERC grant: NE/H021787/1). Subsequent operations targeted a large area of abyssal plain to the south of the currently established PAP-SO research areas. This south area is being considered as the future focus of photographic monitoring of the PAP-SO abyssal benthos.

Table 6.10 AUV and ROV operations at the PAP-SO site

Station number	Operation	Location
JC237-53	M42	Central, trawl, and mooring area
JC237-54	ROV <i>Isis</i> dive 395	Trawl area
JC237-55	ROV <i>Isis</i> dive 396	AESA hill
JC237-56	M43	South area
JC237-57	ROV <i>Isis</i> dive 397	South area

All of these operations were generally very successful, in particular, both Autosub5 missions were extremely productive, each producing c. 60000 high-quality seafloor images. Examples of that imagery are provided below. Most immediately notable was the observation of old (20+ years) epibenthic sledge track marks in the central area. These bermed troughs in the seafloor appear to act as traps for advecting macroplastic debris, and may similarly act to trap organic matter (phytodetritus) potentially influencing the local benthic communities. Several such images show dense aggregations of tubeworms in these troughs that may reflect a response to the local organic enrichment.

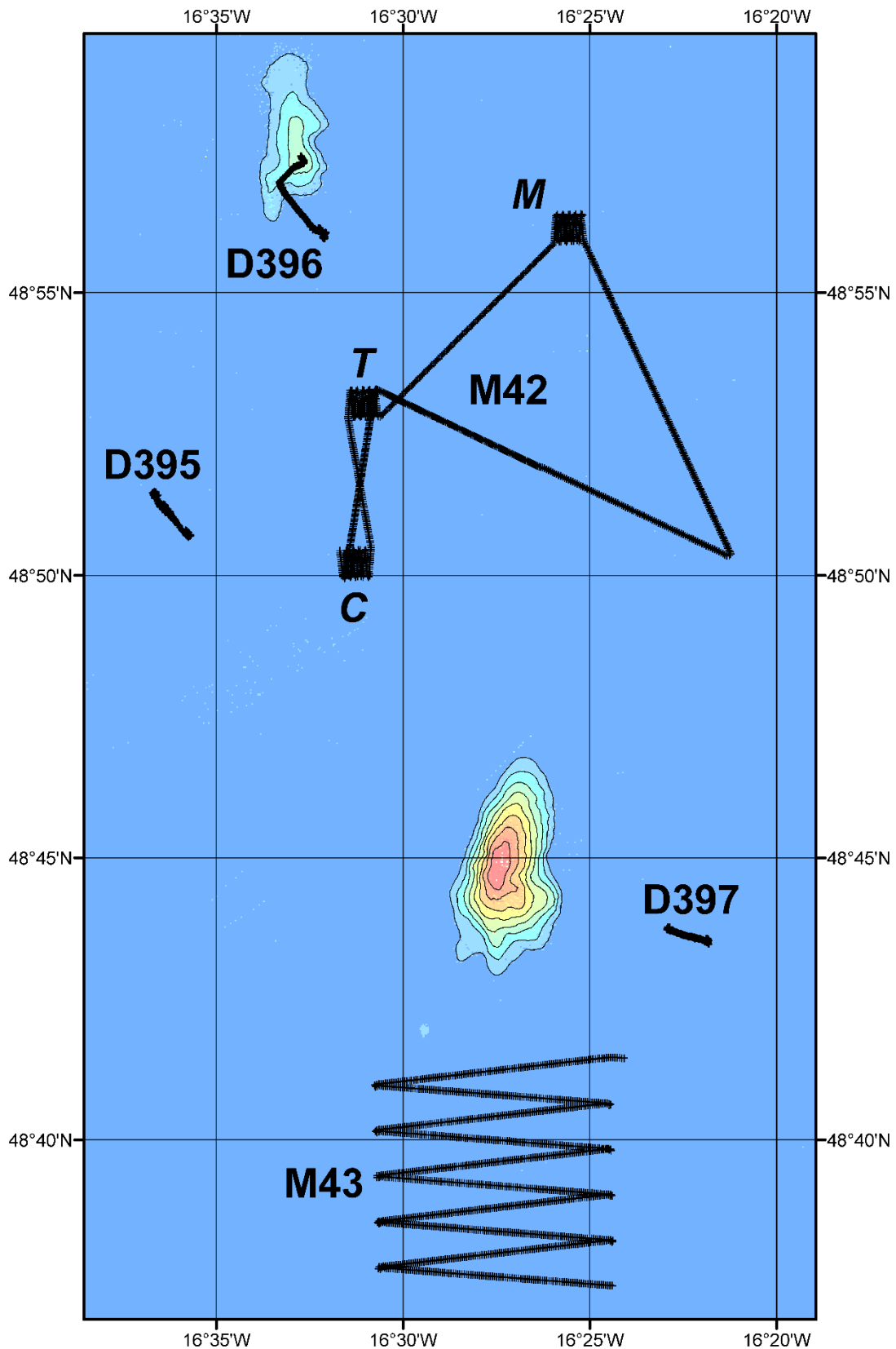

Fig. 6.68 Overview map of the photographic survey in Porcupine Abyssal Plain Sustained Observatory area. Mxx, Autosub5 mission number; Dxxx ROV Isis dive number. NOC PAP team bathymetry, 50 m interval isobaths from 4450 m. World Mercator projection (WKID: 54004)



Fig. 6.69 Examples of Mission 42 (JC237-53) central area seafloor photographs

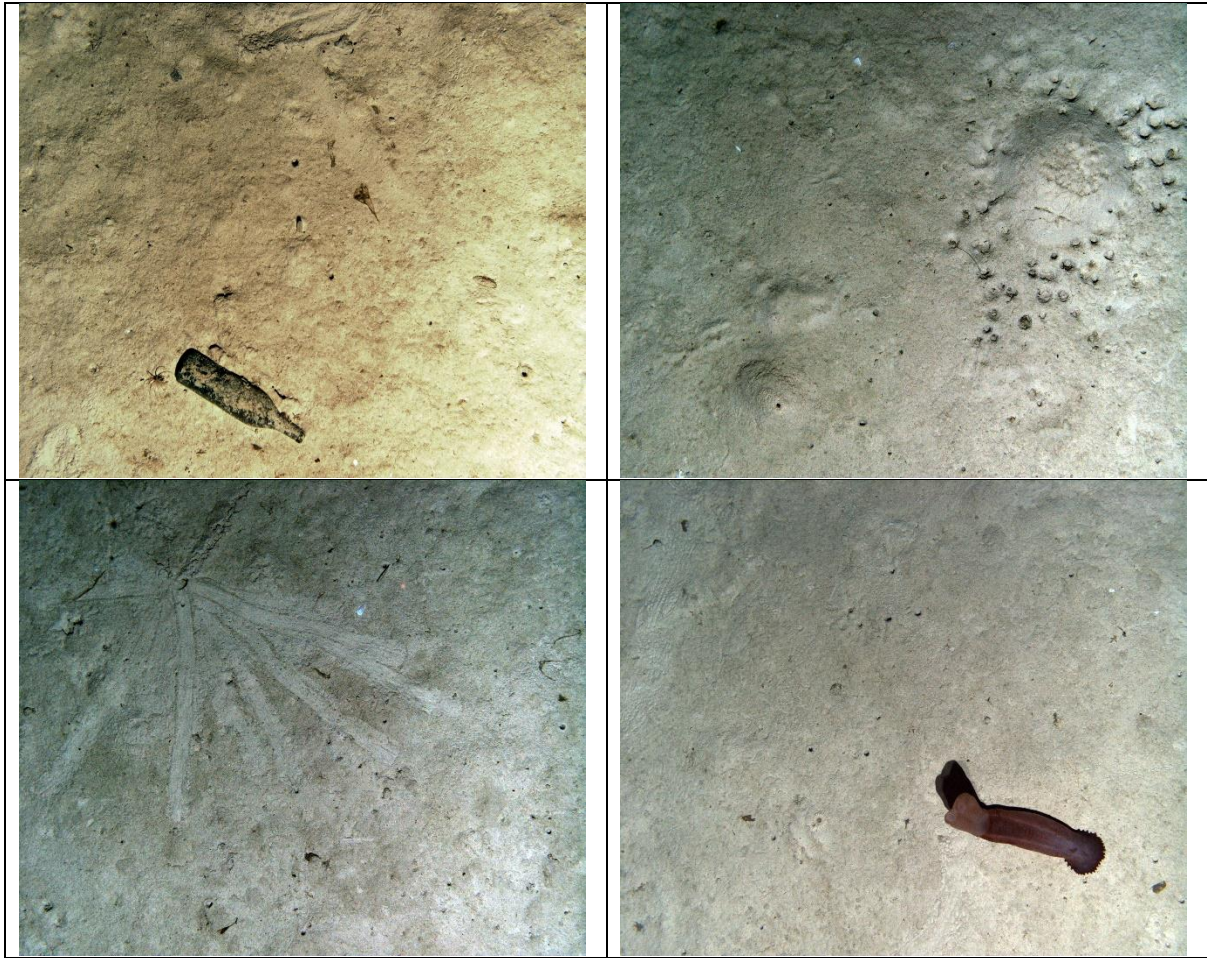

Fig. 6.70 Examples of Mission 42 (JC237-53) trawl area seabed photographs



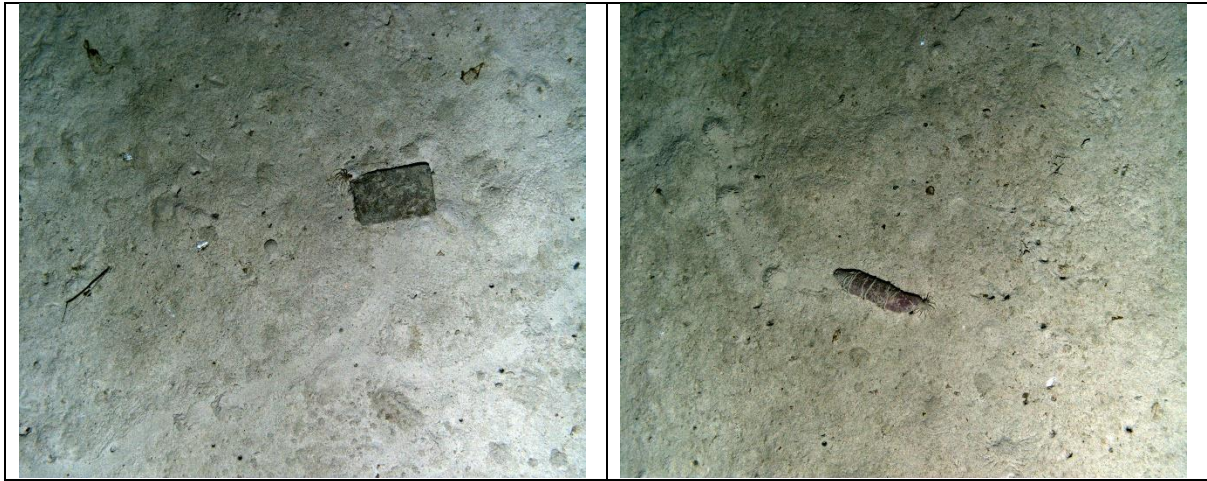

Fig. 6.71 Examples of Mission 42 (JC237-53), PAP mooring area seafloor photographs

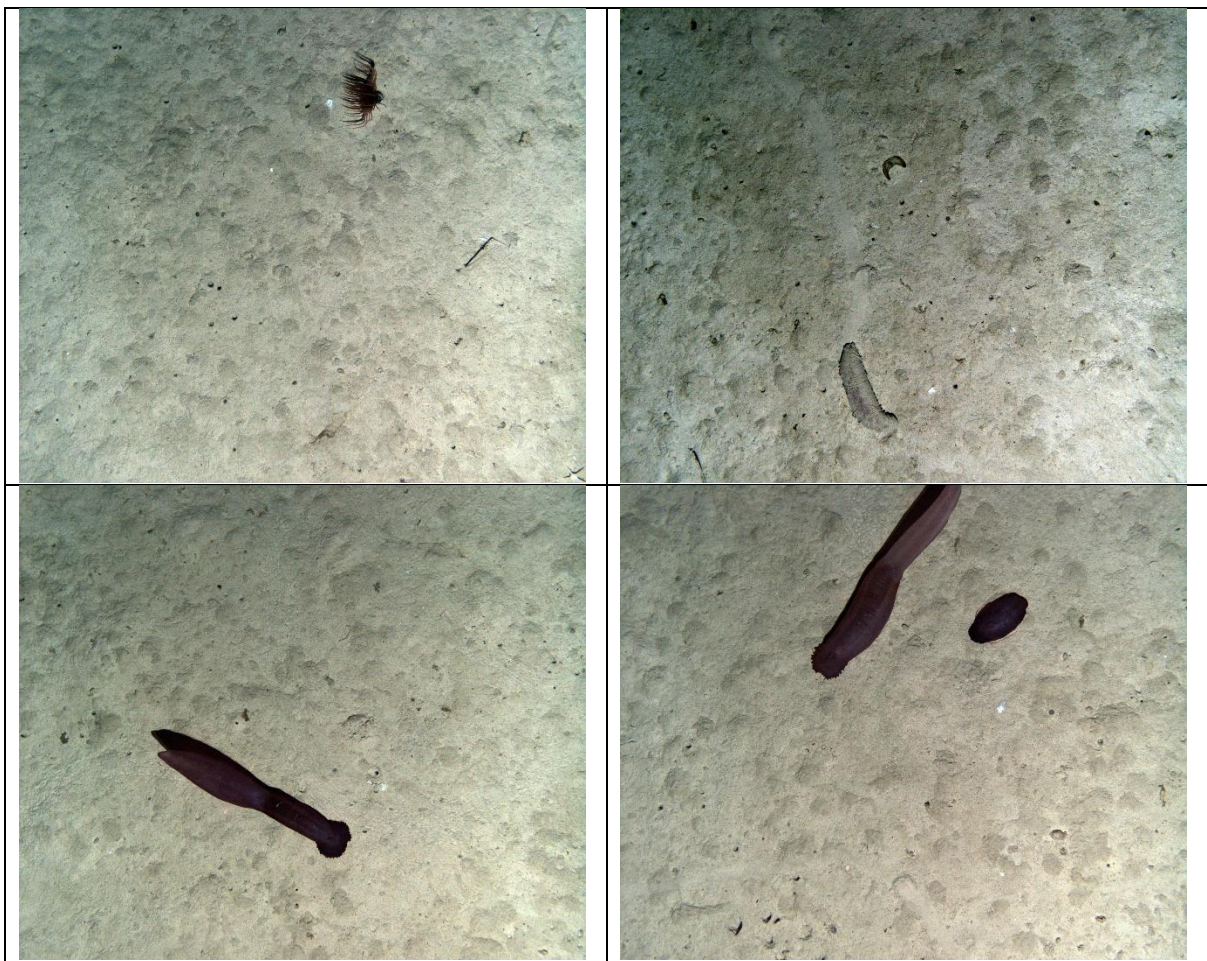

Fig. 6.72 Examples of Mission 43 (JC237-56) PAP south area seafloor photographs

6.2.3. Bathysnap recovery (Brian Bett)

Time-lapse photography has proved to be an effective means of studying the natural history and ecology of the of the deep-sea floor (Bett, 2003). For example, Bett et al. (2001) were able to document the inter- and intra-annual variability in the delivery of phytodetritus, the primary food source of the deep-sea benthos, to the seafloor in the Porcupine Abyssal Plain Sustained Observatory area. The 'Bathysnap' system used to obtain these observations has gone through a number of

iterations and upgrades through its 40-year history (Lampitt & Burnham, 1983). However, recent years have seen a run of failed deployments using commercially available camera systems. Consequently, a new in-house camera system, referred to as 'Bathysnap IV' was developed by the NOC Marine Autonomous Robotic Systems group.

The new Bathysnap IV system was deployed for the first time during RRS *Discovery* cruise 152, at 4060 m water depth in the Whittard Channel. The new camera, FLIR BLACKFLY-S (model BFS-PGE-200S6C: 5472 x 3648 pixel, 20 Megapixel, Colour, Sony IMX183, CMOS, Rolling shutter with global reset, Pixel Size 2.4 μm) was set to fire at 30-minute intervals, coupled with the previously developed "AESAs" 10 J flashgun, together with a newly developed power / control / logging system. The frame was also fitted with two simple tube-type amphipod traps, each baited with three mackerel fillets, and the frame additionally baited with one whole mackerel. At recovery all traces of bait were gone, and in total the two traps contained 17 amphipods that were retained in toto in absolute ethanol, with the intended recipient Dr Tammy Horton (Discovery Collections, NOC).



Fig. 6.73 Amphipod specimens retained from Station DY152-BSNAP-trial

Deployment details:

Deployed	19/07/2022 10:14 (position: 47° 52.335' N 010° 10.006' W)
ETA seabed	19/07/2022 11:21 (triangulated position: 47° 52.383' N 010° 10.192' W)
Released	08/08/2022 10:07 (soak time: c. 20-days; 479-hours)
Surfaced	08/08/2022 11:38

In total only 148 seafloor images were acquired, from 17/07/2022 11:49 to 22/07/2022 13:19, with power failure believed to be the cause of the limited operation. The recorded .RAW image files were batch converted to auto colour corrected .JPG files using IrfanView (5472 x 3458 px, 8 BPP, vertical flip, Bayer RG). The images appeared to be good and of consistent quality. For the next deployment it may be useful to open the lens aperture (this deployment f16) by one or two stops.

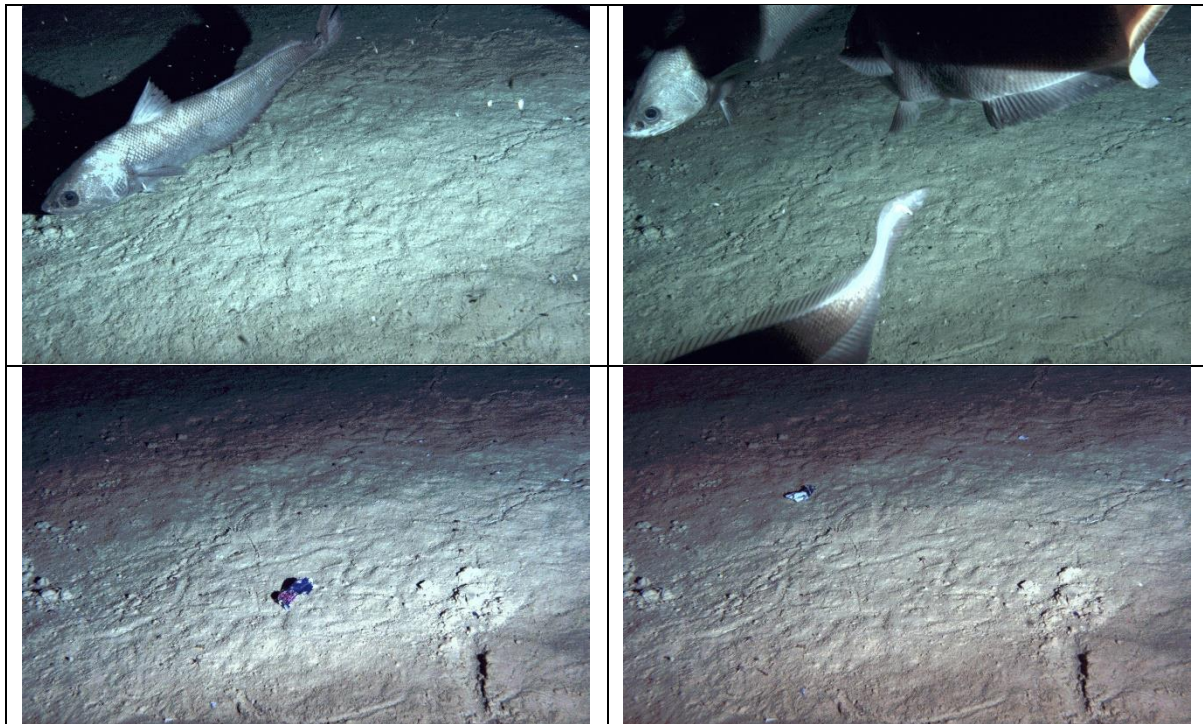

Fig. 6.74 Example photographs from Station DY152-BSNAP-trial. Top left, abyssal grenadier (presumed *Coryphaenoides armatus*). Top right, three abyssal grenadiers, maximum number observed in single image. Bottom left, arrival of macroplastic litter. Bottom right, presumed current driven relocation of litter

6.3. Biological sampling (Brian Bett)

A mix of targeted and opportunistic sampling of biological specimen material was undertaken during the cruise. The material was primarily obtained using ROV *Isis* tools but additionally included the use of amphipod traps on the Bathysnap mooring and use of the Megacore (Table 6.11).

Table 6.11 Biological samples taken

Station number	Event number	Sample type	Water depth	Material retained	Preservation type	Container type	Intended recipient
DY152-BSNAP-trial	na	Amphipod trap catch	4061 m	Amphipoda Live orange Desmophyllum pertusum	Abs. EtOH	500 mL	Tammy Horton / Discovery Collections
JC237-009	010	ROV collection	784 m	Live white Desmophyllum pertusum	Frozen -20 C	Poly. Bag	Gavin Foster
JC237-009	011	ROV collection	784 m	Desmophyllum pertusum	Frozen -20 C	Poly. Bag	Gavin Foster

JC237-012	009	ROV collection	843 m	Live white Desmophyllum pertusum	Frozen -20 C	Poly. Bag	Gavin Foster
JC237-012	010	ROV collection	843 m	Live orange Desmophyllum pertusum	Frozen -20 C	Poly. Bag	Gavin Foster
Jc237-018	013	ROV collection	545 m	Live orange Desmophyllum pertusum	Frozen -20 C	Poly. Bag	Gavin Foster
Jc237-018	014	ROV collection	546 m	Live white Desmophyllum pertusum	Frozen -20 C	Poly. Bag	Gavin Foster
Jc237-018	013	ROV collection	547 m	Desmophyllum spp.	Abs. EtOH	1500 mL	Discovery Collections
Jc237-018	013	ROV collection	548 m	Acesta excavata Misc. invert.s	Abs. EtOH	1500 mL	Discovery Collections
Jc237-018	013	ROV collection	549 m	(crinoids, polychaetes) Desmophyllum spp. (dead framework)	Abs. EtOH	500 mL	Discovery Collections
Jc237-018	013	ROV collection	550 m		Air dried	na	Discovery Collections
JC237-022	012	ROV collection	1136 m	Brachiopoda	Abs. EtOH	1500 mL	Discovery Collections
JC237-022	016	ROV collection (accidental)	? m	Echinoidea Desmophyllum spp. (dead framework)	Abs. EtOH	0.5 L bucket	Discovery Collections
JC237-022	016	ROV collection (accidental)	? m	Misc. invert.s (ophiuroids, bivalves, brachiopods, 'polyps')	Air dried	na	Discovery Collections
JC237-022	016	ROV collection (accidental)	? m	0-5 cm sediment section	Abs. EtOH	500 mL	Discovery Collections
JC237-030	004	ROV push core	802 m	(nematodes) 5-10 cm sediment section	Abs. EtOH	1500 mL	Jeroen Ingels
JC237-030	004	ROV push core	802 m	(nematodes) 0-5 cm sediment section	Abs. EtOH	1500 mL	Jeroen Ingels
JC237-030	005	ROV push core	802 m	(nematodes) 5-10 cm sediment section	Abs. EtOH	1500 mL	Jeroen Ingels
JC237-030	005	ROV push core	802 m	(nematodes) 0-5 cm sediment section	Abs. EtOH	1500 mL	Jeroen Ingels
JC237-030	006	ROV push core	802 m	(nematodes) 5-10 cm sediment section	Abs. EtOH	1500 mL	Jeroen Ingels
JC237-030	006	ROV push core	802 m	(nematodes) 0-5 cm sediment section	Abs. EtOH	1500 mL	Jeroen Ingels
JC237-030	007	ROV push core	795 m	(nematodes)	Abs. EtOH	1500 mL	Jeroen Ingels

JC237-030	007	ROV push core	795 m	5-10 cm sediment section (nematodes)	Abs. EtOH	1500 mL	Jeroen Ingels
JC237-030	008	ROV push core	795 m	0-5 cm sediment section (nematodes)	Abs. EtOH	1500 mL	Jeroen Ingels
JC237-030	008	ROV push core	795 m	5-10 cm sediment section (nematodes)	Abs. EtOH	1500 mL	Jeroen Ingels
JC237-030	009	ROV push core	795 m	0-5 cm sediment section (nematodes)	Abs. EtOH	1500 mL	Jeroen Ingels
JC237-030	009	ROV push core	795 m	5-10 cm sediment section (nematodes)	Abs. EtOH	1500 mL	Jeroen Ingels
JC237-030	010	ROV push core	822 m	0-5 cm sediment section (nematodes)	Abs. EtOH	1500 mL	Jeroen Ingels
JC237-030	010	ROV push core	822 m	5-10 cm sediment section (nematodes)	Abs. EtOH	1500 mL	Jeroen Ingels
JC237-030	011	ROV push core	822 m	0-5 cm sediment section (nematodes)	Abs. EtOH	1500 mL	Jeroen Ingels
JC237-030	011	ROV push core	822 m	5-10 cm sediment section (nematodes)	Abs. EtOH	1500 mL	Jeroen Ingels
JC237-030	012	ROV push core	822 m	0-5 cm sediment section (nematodes)	Abs. EtOH	1500 mL	Jeroen Ingels
JC237-030	012	ROV push core	822 m	5-10 cm sediment section (nematodes)	Abs. EtOH	1500 mL	Jeroen Ingels
JC237-033	na	Megacore (10 cm ID)	2124 m	0-5 cm sediment section (nematodes)	Abs. EtOH	1500 mL	Jeroen Ingels
JC237-033	na	Megacore (10 cm ID)	2124 m	5-10 cm sediment section (nematodes)	Abs. EtOH	1500 mL	Jeroen Ingels
JC237-046	002	ROV collection	1616 m	Porifera (white fan sponge)	Abs. EtOH	0.5 L bucket	Discovery Collections
JC237-046	003	ROV collection	1616 m	Alcyonacea + associated Polychaeta	Abs. EtOH	0.5 L bucket	Discovery Collections
JC237-046	004	ROV collection	1616 m	Alcyonacea + associated Ophiuroidea	Abs. EtOH	0.5 L bucket	Discovery Collections
JC237-046	005	ROV collection	1616 m	Live orange Desmophyllum pertusum	Frozen -20 C	Poly. Bag	Gavin Foster
JC237-046	005	ROV collection	1616 m	Polychaeta (D. pertusum associated)	Abs. EtOH	500 mL	Discovery Collections
JC237-048	002-3	ROV collection	646-648 m	Live orange Desmophyllum pertusum	Frozen -20 C	Poly. Bag	Gavin Foster

JC237-048	002-3	ROV collection	646-648 m	Live orange Madrepora oculata	Frozen -20 C	Poly. Bag	?Gavin Foster
JC237-050	003	ROV collection	1083 m	Live Desmophyllum pertusum	Frozen -20 C	Poly. Bag	Gavin Foster
JC237-050	005	ROV collection	1083 m	Live Desmophyllum pertusum	Frozen -20 C	Poly. Bag	Gavin Foster
JC237-050	008	ROV collection	970 m	Live Desmophyllum pertusum	Frozen -20 C	Poly. Bag	Gavin Foster
JC237-050	009	ROV collection	970 m	Desmophyllum pertusum	Frozen -20 C	Poly. Bag	Gavin Foster
JC237-054	007	ROV collection	4843 m	Polychaeta	Abs. EtOH	500 mL	Discovery Collections
JC237-054	008	ROV collection	4844 m	? Sample of 'fairy ring'	Abs. EtOH	25 mL Sterilin	Discovery Collections
JC237-054	009	ROV collection	4843 m	? Polychaeta ('cone beast')	Abs. EtOH	25 mL Sterilin	Discovery Collections
JC237-054	010	ROV collection	4843 m	Scleractinia	Abs. EtOH	0.5 L bucket	Discovery Collections
JC237-054	011	ROV collection	4843 m	Ceriantharia	Abs. EtOH	500 mL	Discovery Collections
JC237-054	012	ROV collection	4843 m	Ceriantharia	Abs. EtOH	500 mL	Discovery Collections
JC237-054	014	ROV collection	4843 m	? Polychaeta ('stick thing')	Abs. EtOH	1500 mL	Discovery Collections
JC237-054	017	ROV collection	4842 m	Porifera & Actinaria	Abs. EtOH	0.5 L bucket	Discovery Collections
JC237-054	018	ROV collection	4842 m	Holothuroidea (Amperima)	Abs. EtOH	500 mL	Discovery Collections
JC237-055	001	ROV collection	4837 m	Actinaria	Abs. EtOH	500 mL	Discovery Collections
JC237-055	002	ROV collection	4837 m	Actinaria	Abs. EtOH	500 mL	Discovery Collections
JC237-055	003	ROV collection	4837 m	Actinaria	Abs. EtOH	25 mL Sterilin	Discovery Collections
JC237-055	004	ROV collection	4837 m	Ceriantharia	Abs. EtOH	500 mL	Discovery Collections
JC237-055	005	ROV collection	4836 m	Ceriantharia	Abs. EtOH	500 mL	Discovery Collections
JC237-055	006	ROV collection	4836 m	Actinaria	Abs. EtOH	500 mL	Discovery Collections
JC237-055	009	ROV collection	4630 m	Holothuroidea (highly fragmented)	Abs. EtOH	0.5 L bucket	Discovery Collections
JC237-055	010	ROV collection	4629 m	Holothuroidea ("Psychropotes longicauda")	Abs. EtOH	20 L bucket	Discovery Collections
JC237-055	011	ROV collection	4629 m	Actinaria	Abs. EtOH	500 mL	Discovery Collections
JC237-055	012	ROV collection	4629 m	Actinaria	Abs. EtOH	500 mL	Discovery Collections
JC237-055	013	ROV collection	4629 m	Ceriantharia	Abs. EtOH	500 mL	Discovery Collections

JC237-057	001-2-3	ROV collection	4839 m	Holothuroidea (Amperima)	Abs. EtOH	1500 mL	Discovery Collections
JC237-057	006	ROV collection	4839 m	Actinaria (Isactis)	Abs. EtOH	500 mL	Discovery Collections
JC237-057	007	ROV collection	4840 m	Ascidiacea (Culeolus)	Abs. EtOH	500 mL	Discovery Collections
JC237-057	008	ROV collection	4840 m	Porifera (Hexactinellida)	Abs. EtOH	1500 mL	Discovery Collections
JC237-057	009	ROV collection	4841 m	Ascidiacea (Octacnemus)	Abs. EtOH	500 mL	Discovery Collections
JC237-057	012	ROV collection	4841 m	Scleractinia	Abs. EtOH	500 mL	Discovery Collections
JC237-057	013	ROV collection	4841 m	Ascidiacea (Octacnemus)	Abs. EtOH	500 mL	Discovery Collections
JC237-057	017	ROV collection	4841 m	Holothuroidea (Amperima) - specimen I	Abs. EtOH	500 mL	Discovery Collections
JC237-057	017	ROV collection	4841 m	Holothuroidea (Amperima) - specimen I	RNA Later - 80 C	Falcon tube	Rachel Jeffreys
JC237-057	017	ROV collection	4841 m	Holothuroidea (Amperima) - specimen II	Abs. EtOH	500 mL	Discovery Collections
JC237-057	017	ROV collection	4841 m	Holothuroidea (Amperima) - specimen II	RNA Later - 80 C	Falcon tube	Rachel Jeffreys
JC237-057	017	ROV collection	4841 m	Holothuroidea (Amperima) - specimen III	Abs. EtOH	500 mL	Discovery Collections
JC237-057	017	ROV collection	4841 m	Holothuroidea (Amperima) - specimen III	RNA Later - 80 C	Falcon tube	Rachel Jeffreys
JC237-057	017	ROV collection	4841 m	Holothuroidea (Amperima) - specimen IV	Abs. EtOH	500 mL	Discovery Collections
JC237-057	017	ROV collection	4841 m	Holothuroidea (Amperima) - specimen IV	RNA Later - 80 C	Falcon tube	Rachel Jeffreys
JC237-057	020	ROV collection	4841 m	Crinoidea	Abs. EtOH	1500 mL	Discovery Collections
JC237-057	021	ROV collection	4840 m	Actinaria	Abs. EtOH	500 mL	Discovery Collections
JC237-057	021	ROV collection	4840 m	Actinaria	RNA Later - 80 C	Falcon tube	Rachel Jeffreys
JC237-057	022	ROV collection	4840 m	Actinaria	Abs. EtOH	500 mL	Discovery Collections
JC237-057	022	ROV collection	4840 m	Actinaria	RNA Later - 80 C	Falcon tube	Rachel Jeffreys
JC237-057	022	ROV collection	4840 m	Ophiuroidea	Abs. EtOH	500 mL	Discovery Collections
JC237-065	003	ROV collection	3151 m	Holothuroidea	Abs. EtOH	500 mL	Discovery Collections
JC237-065	005	ROV collection	3151 m	Holothuroidea	Abs. EtOH	500 mL	Discovery Collections
JC237-065	011	ROV collection	3074 m	? Octocorallia	Abs. EtOH	1500 mL	Discovery Collections
JC237-065	011	ROV collection	3074 m	Holothuroidea	Abs. EtOH	500 mL	Discovery Collections

JC237-065	012	ROV collection ROV collection (incidental, from 'waste chamber)	3074 m 3151 / 3074 m	? Octocorallia Holothuroidea	Abs. EtOH Abs. EtOH	500 mL 500 mL	Discovery Collections Discovery Collections
-----------	-----	---	----------------------------	-------------------------------------	----------------------------	----------------------	--

6.3.1. Live *Desmophyllum pertusum* Sampling

Twelve targeted collections of live *Desmophyllum pertusum* were made (Table 6.11) within the Whittard Canyon system, spanning water depths of 545-1616 m. The material was photographed, placed in polythene bags, and promptly transferred to a -20° C freezer. These samples will be transferred to Professor Gavin Foster, University of Southampton, for further analysis.

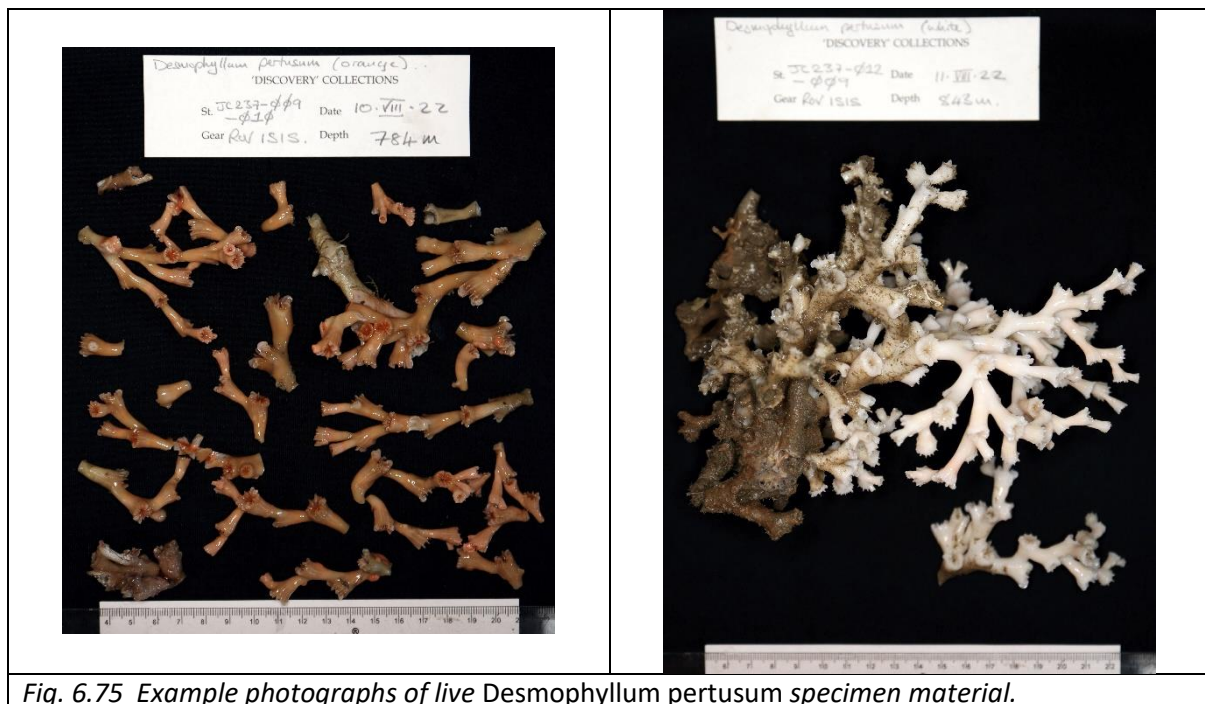

Fig. 6.75 Example photographs of live *Desmophyllum pertusum* specimen material.

6.3.2. Fossil coral sampling

Two collections of fossil (dead coral framework) coral material were made, the first (JC237-018-13) from 550 m water depth, the second (JC237-022-16) of uncertain depth, representing an accidental recovery on the body of the ROV (Table 6.8). This material was photographed and allowed to air dry in the constant temperature laboratory.



Fig. 6.76 Example photographs of fossil coral (*Desmophyllum* spp.) specimen material.

6.3.3. Sampling for Taxonomy and Identification

Sixteen opportunistic collections of specimen material were made in the Whittard Canyon system, spanning water depths of 547-3151 m. The material was photographed and preserved in absolute ethanol. This material will be retained in the Discovery Collections at the NOC.

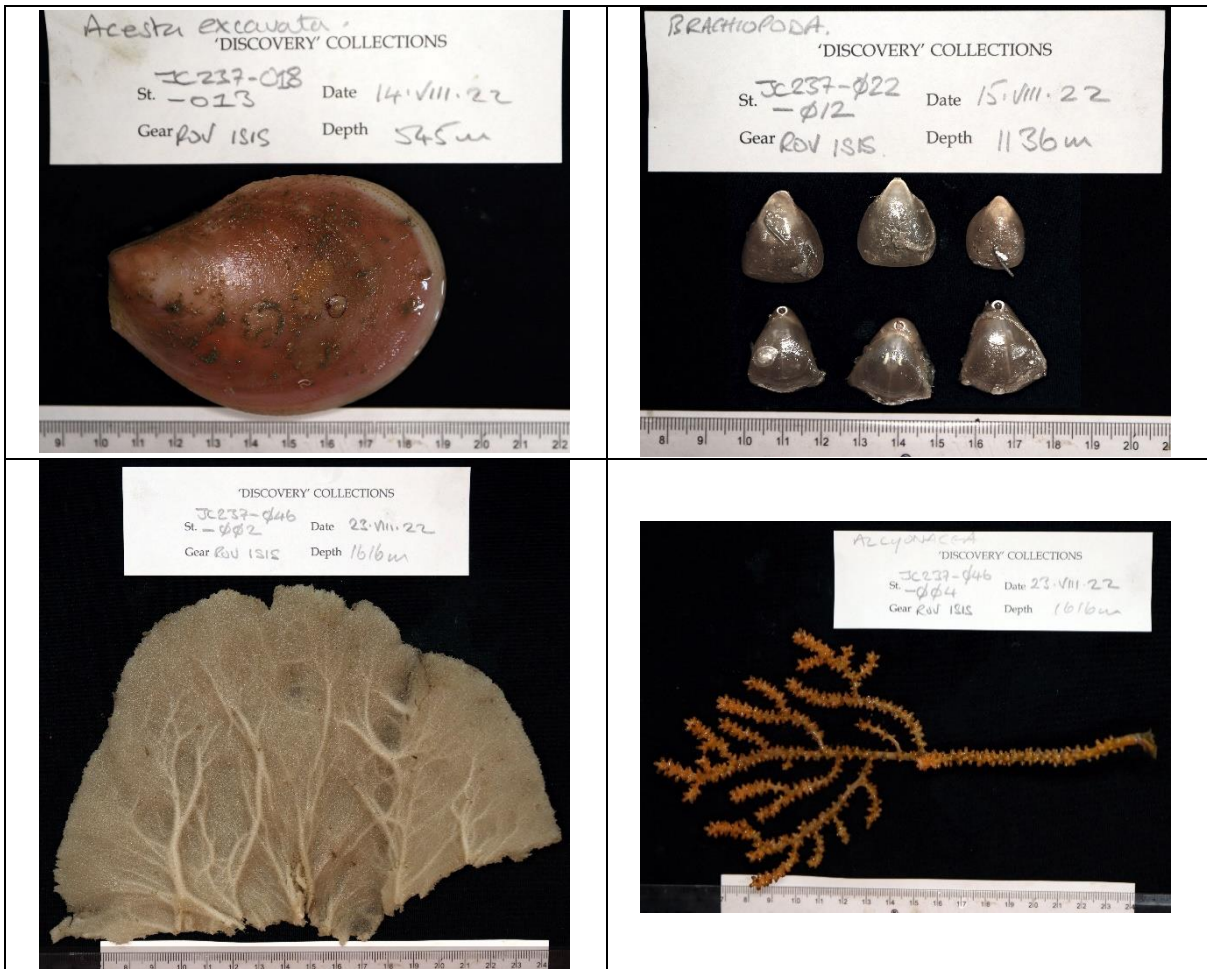

Fig. 6.77 Example photographs of opportunistic specimen collections from the Whittard Canyon system.

Targeted collections of biological specimen material were undertaken during ROV *Isis* dives in the Porcupine Abyssal Plain Sustained Observatory area (Stations: JC237-054 / 055 / 057). A target list of desired specimen material was prepared by Andrew Gates, Jennifer Durden, and Tammy Horton (NOC, OBG, Seafloor Ecosystems), who were additionally able to join the ROV dives remotely. In total, 35 separate samples were retained from water depths of 4629-4844 m, encompassing abyssal hill and abyssal plain environments. These specimens were photographed where possible, then preserved in absolute ethanol. This material will be retained in the Discovery Collections at the NOC.



Fig. 6.78 Example photographs of targeted specimen collections in the Porcupine Abyssal Plain Sustained Observatory area.

6.3.4. Occurrence of desaturase genes in deep-sea fauna

To support a prospective future project assessing the potential occurrence of desaturase genes, required to biosynthesis polyunsaturated fatty acids de novo, in deep-sea species, six of the targeted specimens from the Porcupine Abyssal Plain Sustained Observatory area were tissue subsampled. In each case a c. 1 × 1 cm section of body wall was dissected, placed in a Falcon tube, preserved with RNAlater, and then stored in a -80° C freezer. The remainder of each specimen was separately retained in absolute ethanol to enable subsequent confirmation of identify by detailed morphological examination. The tissue samples will be transferred to Dr Rachel Jeffreys, University of Liverpool, for further processing. The ethanol preserved specimen remainders will be retained in the Discovery Collections at the NOC.

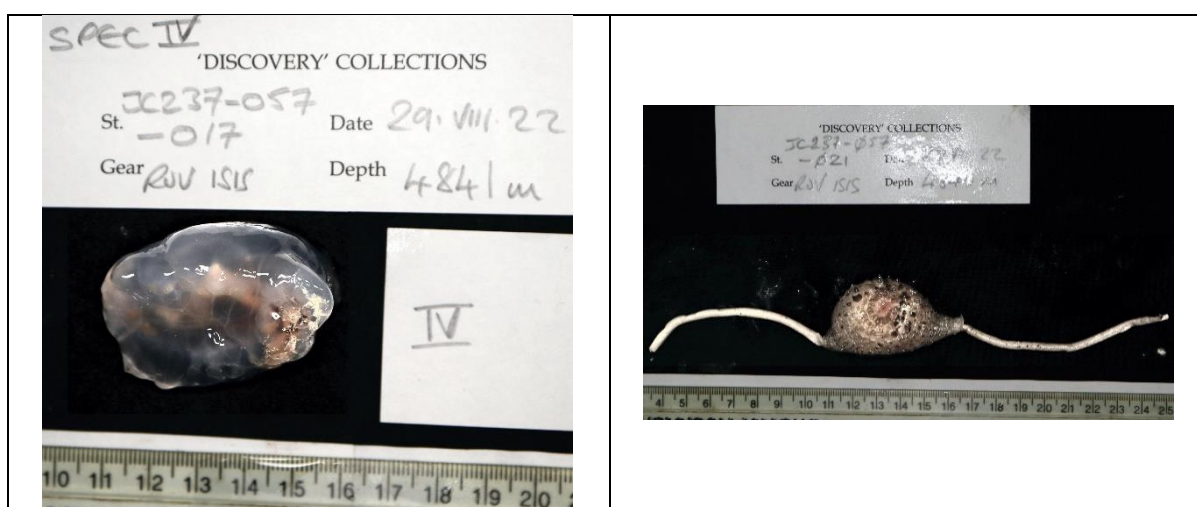

Fig. 6.79 Example photographs of specimens that were tissue subsampled from the Porcupine Abyssal Plain Sustained Observatory area.

6.3.5. Free-living nematodes associated with symbiotic bacteria in the Whittard Canyon

Tchesunov et al. (2012) reported the collection of two species of nematode associated with symbiotic bacteria, *Parabostrichus bathyalis* and *Astomonema southwardorum*, from the Whittard Canyon and Gollum Channel systems, in water depths of 755-1090 m. The former, a member of the Stilbonematinae, bearing sulphur-oxidising ectosymbiont prokaryotes, and the latter, a member of the Astomonematinae, bearing sulphur-oxidising endosymbiont prokaryotes. Both of these nematode subfamilies are relatively well known for these symbiont associations in shallow-water habitats and are known or presumed to be associated with the 'sulphide system'. Stilbonematinae had previously been reported from the deep sea in samples from the Darwin Mounds, c. 950 m water depth, collected on RRS *Discovery* cruise 248 (Bett et al., 2001) as detailed by Van Gaever et al. (2006). Astomonematinae had previously been reported from c. 3400 m water depth in the Nazaré Canyon (Ingels et al., 2009), and at 3214 m and 4241 m water depths in Cascais and Setúbal Canyons respectively (Ingels et al., 2011).

Table 6.12 Nematode samples retained

Station number	Event number	Sample type	Water depth	Material retained
JC237-030	004	ROV push core	802 m	0-5 & 5-10 cm sediment sections
JC237-030	005	ROV push core	802 m	0-5 & 5-10 cm sediment sections

JC237-030	006	ROV push core	802 m	0-5 & 5-10 cm sediment sections
JC237-030	007	ROV push core	795 m	0-5 & 5-10 cm sediment sections
JC237-030	008	ROV push core	795 m	0-5 & 5-10 cm sediment sections
JC237-030	009	ROV push core	795 m	0-5 & 5-10 cm sediment sections
JC237-030	010	ROV push core	822 m	0-5 & 5-10 cm sediment sections
JC237-030	011	ROV push core	822 m	0-5 & 5-10 cm sediment sections
JC237-030	012	ROV push core	822 m	0-5 & 5-10 cm sediment sections
JC237-033	na	Megacore (10 cm ID)	2124 m	0-5 & 5-10 cm sediment sections

Triplicate nematode samples were obtained from three water depths (795, 802, and 822 m) during ROV *Isis* dive 389 (Stn JC237-030). Additional samples were obtained by Megacore from 2124 m water depth as Stn JC237-033. In all cases, samples were processed as follows: cores were gently extruded allowing top water to overspill; the last c. 1 cm of top water was removed by careful syringing; the 0-5 cm section of the sediment column was extruded into a measured cutting ring and cut with a sharpened metal cutting plate; the sectioned sediment was quantitatively transferred to a 1500 mL UN plastic bottle and the material preserved in absolute ethanol; the process was repeated for the 5-10 cm section of the sediment column. Samples were gently agitated on initial preservation and again c. 1-hour later in an attempt to ensure good preservation. All shipboard processing and storage of samples was carried out in a constant temperature laboratory (c. 8-10 °C).

The samples will be initially stored in the Discovery Collections at NOC before intended onward transport to Dr Jeroen Ingels, Florida State University Coastal and Marine Lab.

6.4. Settling experiment (*James Strong*)

Two settlement experiments were deployed on the interfluvial south of Dangaard Canyon, during ROV Dive382. One of the experiments was a modified ARMS unit, a settlement structure commonly used in shallow coral reefs (Brainard et al., 2009). It was provided by Prof. Louise Allcock from the National University Ireland, Galway, and will be recovered in summer 2023 with the ROV Holland I on board the RV Celtic Explorer.

The second structure was designed in house, and is larger than the ARMS unit. The structure that holds the panels was designed to provide an element of elevation above the seabed to emulate the benefit provided by the elevation of the once colonised mounds (Fig. 6.80): elevation was assumed to have contributed to the moderately high growth rates seen within colonies present on marker buoys at the Darwin Mounds (Huvenne & Thornton, 2020). The framework also pitches the panels at 45 degrees to reduce the accumulation of silt. The four panels on the frame are corrugated concrete roofing tiles. Half of each dorsal surface was treated with a lime wash (Womersleys White Peak Buxton Lime Wash) to test whether a surface enriched with calcium might be a more conducive settlement surface for cold-water coral larvae. This larger structure will be left on the seabed for a longer time.

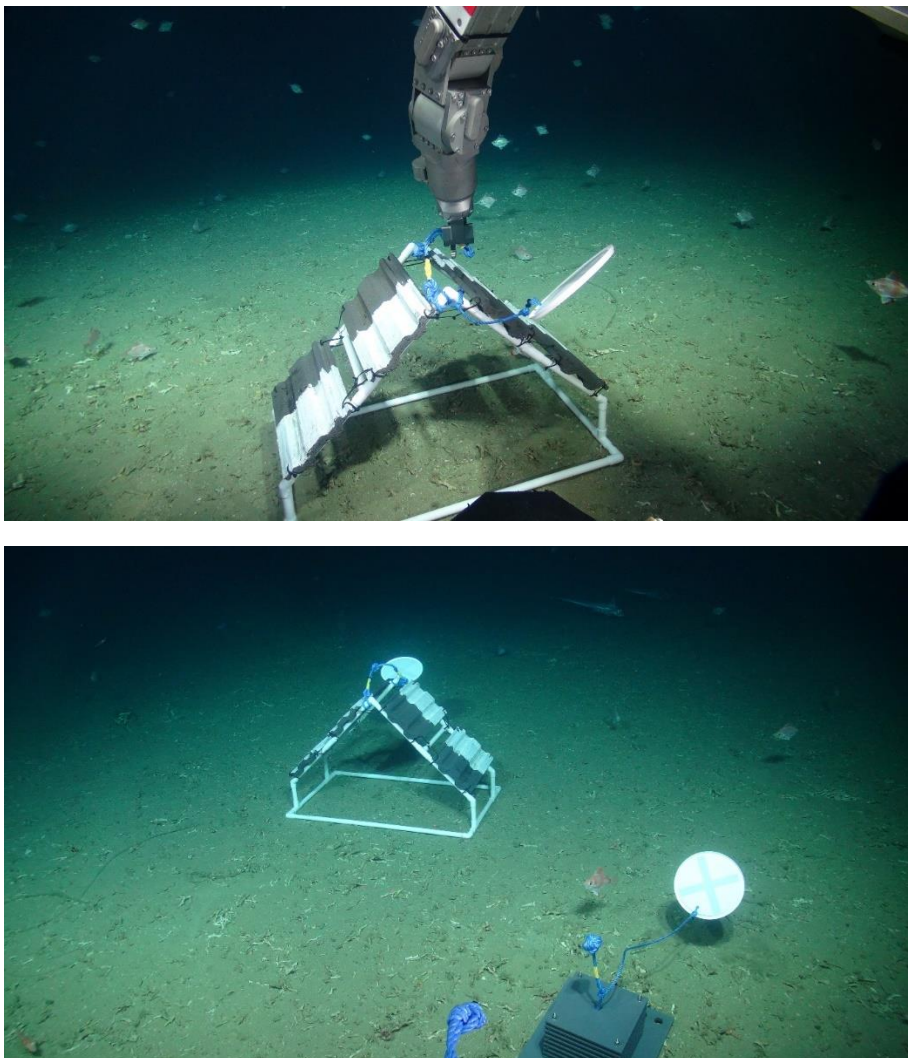

Fig. 6.80 Settlement panels being deployed by the ISIS ROV on the interfluvial minimounds site at Whittard Canyon (top). The panels are located next to an Autonomous Reef Monitoring Structures (ARMS; courtesy of Dr. Louise Allcock, NUI Galway,) unit, which also provides a colonisable space for small epifaunal species (bottom)

Once the panels are collected, potentially in 4-5 years time, they will hopefully provide some important information about the processes that support cold-water coral recovery locally. Furthermore, the use of panels and panel coats provides some preliminary testing of the value of artificial surfaces to support active restoration practices in the deep sea.

6.5. Coring (*Esther Sumner, Michael Clare*)

6.5.1. ROV pushcores

Push cores were collected using the manipulator arm on the ROV ISIS. These push core samples will be used to analyse: 1) the distribution of sediment (composition, size), microplastics, organic carbon and eDNA within the canyon system; 2) changes in grain composition and size with altitude above the thalweg in the Eastern Branch. The purpose of the latter is to better constrain the character of sediment-gravity flows that have been directly measured within this canyon branch.

In total 118 push cores were collected: 90 within the Whittard Canyon System and 28 (a mixture of sedimentological and biological samples) within the Porcupine Abyssal Plain. Push cores were collected during the following ROV dives: 383, 385, 386, 387, 388, 389, 390, 391, 394, 396, 397, and 398. Push cores collected at the Porcupine Abyssal Plain were either extruded and subsampled for fauna, or were kept whole and frozen at -20°C for later analysis of sediment grain size and organic carbon (cores 'in trawl mark' or 'background' – see station list in Appendix). In the Whittard Canyon, cores were collected during each dive at a range of water depths, typically including the deepest and shallowest seafloor locations during the dive. Typically, a pair of cores were collected at each coring locality, with one core designated for organic carbon and eDNA analyses and the other for microplastic and sedimentological analyses. All cores were photographed prior to subsampling.

Subsampling – organic carbon and eDNA. Pushcores were sliced at 1 cm intervals and the sample split in two with half of the sample for organic carbon analysis and half for eDNA analysis. Cutting tools were washed with water, followed by 70% alcohol and then milliQ between each slice. The samples were stored at -80°C.

Subsampling – microplastics and sedimentological analyses. Pushcores were sliced at 1 cm intervals and the sample split in two with half of the sample wrapped in foil for microplastics analyses and half retained for other sedimentological analyses (e.g. grain size, ²¹⁰Pb). Cutting tools were cleaned using water between slices. During sampling 100% cotton labcoats were worn to protect samples from contamination with microfibres. Ambient plastics were collected on a filter paper during core processing. Samples were taken of any plastics within the core processing area. If cores showed exceptional stratigraphy then the core was preserved intact, rather than slicing. All samples were stored at 4 °C.

6.5.2. Gravity Coring

Gravity cores were used to investigate: 1) areas of deposition from sediment-laden gravity currents in the Eastern Canyon branch (JC237-024-GC03 to JC237-044-GC10); and 2) the nature of sedimentation in a canyon branch with unusual 'annealed' morphology (JC237-020-GC01 to JC237-021-GC02). Cores in excess of 1.5 m length were cut into ~1.5 m sections but were not split lengthwise. Cores were

stored horizontally at 4 °C. The descriptions below are based on observations of the limited view through the clear core liner.

A previous core collected by colleagues at NIOZ revealed a thickness of sediment including thin-bedded turbidites at 48° 31' 46.165 N, 9° 56' 7.63 W. This core was located between two moorings that were deployed from 2019 to 2020 that directly monitored sediment-laden gravity currents (Heijnen et al., 2022). During this cruise (JC237) gravity coring was used to explore the extent of deposition from sediment-laden gravity currents in this area. It was found that deposition is localised to the terrace on which the 'NIOZ core' was collected. Coring was attempted on terraces, and in the channel, upstream and downstream from the 'NIOZ core' location. Typically, these cores sampled very stiff clay in the core catcher, or stiff clay overlain by a thin deposit of looser sediment. Thus, sedimentation in the area of the NIOZ core appears to be of limited extent. A subsequent gravity core (JC237-059-GC12) alongside a mega core (JC237-063-MGC05) and push cores were collected ~25 km downstream (thalweg distance) from the NIOZ core in a region where the channel belt broadens. These cores reveal stacks of thin bedded, fine sand turbidites in the channel-belt (both thalweg and overbank areas).

Cores (JC237-020-GC01 to JC237-021-GC02) collected in the canyon tributary parallel to the Acesa branch (Western Middle Branch), and displaying an unusual 'annealed' morphology are similar in character to those in the Eastern Branch with decimetres of fine sand overlying stiff clay.

6.5.3. Megacoring

Megacores were used to: 1) characterise sediments in interfluvial areas, providing a baseline sample at the start of the trawling ban in the MCZ; 2) Provide sediment samples to complement SAPS filtering sites; 3) Provide samples for sedimentological analyses (composition, grain size, stratigraphy), dating (^{210}Pb), microplastics and organic carbon.

The megacorer was deployed with eight out of the possible 12 core tubes (10 cm diameter). Core tubes were assigned for processing in the following priority order: 1) stratigraphy; 2) organic carbon and eDNA; 3) microplastics; 4) SAPS; 5) ^{210}Pb , 6) grain size; any excess cores were subcored with gravity core liner and stored at 4 °C. SAPS and organic carbon samples were processed first. Subsampling for organic carbon, eDNA and microplastics follow the procedures outlined in section 6.5.1.

Subsampling SAPS – The core was cleaned and placed vertically in the -80°C freezer. Following freezing the core was warmed sufficiently to allow extrusion, wrapped in foil and stored at -80°C.

Subsampling stratigraphy, ^{210}Pb , grain size and spare cores – subcored using polypropylene gravity core liner, capped and stored vertically at 4 °C.

6.6. Geological observations (*Gareth Carter, Silvia Ceramicola*)

6.6.1. Geological highlights from ROV dives

During the JC237 cruise, 17 Remotely Operated Vehicle (ROV) dives were undertaken, with both biological and geological aims. The main geological objectives outlined for the ROV dives were to:

- 1) Obtain information about how active the canyon is today and about the different processes and dynamics at different branches during canyon evolution (sedimentation vs. erosion) with a specific interest in mass wasting of slopes;
- 2) Obtain as much lithological information as possible about the different geological formations the canyon has incised down into over time;
- 3) Learn about the rock behaviour of the different units exposed along the canyon walls (rock properties, stress and strain) and how this is responsible for canyon slope mass wasting;
- 4) Understand the role of benthic species in wall erosion and in mass wasting processes; and
- 5) Which geological (i.e. lithology, morphology) conditions are key for benthic species to thrive?

For this purpose, during Dives 384 and 392, the ROV was equipped with a rock drill that enabled the collection of approximately 20 cm-long rock cores. When the ROV could not be equipped with the rock drill (because other pieces of equipment had priority) or the ROV could not land on a specific site of interest (i.e. terraces) because of rough terrain or high slope gradients, the ROV collected loose samples selected using geological reasoning (i.e. adjacent to a steep wall or on a terrace, clearly belonging to a certain geological unit previously recognised/identified by video footage). Another important tool we used when it was not possible to collect rock drill or loose rock samples, was the opportunity to scratch or probe the wall surface or the terrace pavement with the ROV's claw, to gain a basic appreciation of the substrate composition and competency, as is often done with a hammer in the field onshore.

The possibility of collecting samples of in situ rock from the walls and from the terraces of the canyon is particularly interesting as these samples are likely to reveal important information about rock properties (e.g. grain size, sorting, strength, porosity) and thus how prone these units are to erosion and mass wasting. In addition, information regarding provenance and depositional environment under which these rock units were formed can also be obtained. Integrating all this information will allow the team to assess the erosional character of the different Whittard Canyon branches inspected and to draw important conclusions about the overall erosional character of Whittard Canyon slopes.

Four branches were inspected with geological ROV dives during JC237, the Dangaard (Dives 386 and 394), the Explorer (Dives 383, 384, 392, 393, 398), the Eastern Branch (Dives 387, 388, 390) and West Middle Branch (Dives 387,388, 389), see Fig 6.81. A total of 28 samples (Fig. 6.81 and Table 6.13) were collected.



Fig. 6.81 On the left, different locations of the ROV dives and in inset the total number and types of geological samples collected: on the right the geological samples collected during the ROV dives in the Whittard Canyon

Here, we highlight some of the most interesting geological aspects encountered during the JC237 ROV dives.

Generalised bedding observations along the canyon walls

A target of most of the geological ROV dives was the investigation of slope areas where bedrock was suspected to outcrop at the seabed in four different canyon branches, including areas of several hundred meters high sub-vertical canyon walls. Preliminary observations allow us to recognise four different generalised rockwall types (see Fig. 6.82):

- 1) Massive (weak/no obvious evidence of bedding);
- 2) Medium to thickly bedded (alternating beds with thickness of >20 cm and apparent similar erosion resistance);
- 3) Very thinly to thinly bedded (alternating bed thicknesses of <20 cm and apparent similar erosion resistance); and
- 4) Bedded with ledges and overhangs (alternate beds of erosion-resistant vs erosion-susceptible units, providing ledges and overhangs that were frequently colonised by coral and clam communities).



Fig 6.82 Different rockwall settings observed during ROV dives in the Whittard canyon: a) Weakly bedded mudstone / very stiff clay exhibiting exfoliation surfaces, b) Very thin to thin bedded with ledges / overhangs, c) Thinly bedded sandstone

Evidence of mass wasting

Several instances of failures, landslides, and mass wasting were observed along the walls and terraces. More specifically, we encountered the following modes of failures/erosion during JC237 cruise (Fig. 6.83):

- 1) Exfoliation of massive rockwall surfaces;
- 2) Retrogressive retreat of stepped, terraced slopes;
- 3) Creation of overhangs by selective erosion;
- 4) Undercutting / undermining base of steep gradient slopes and cliffs (unbuttressing), and
- 5) Spalling of hand-sized clasts from exposed terraces and cliff faces

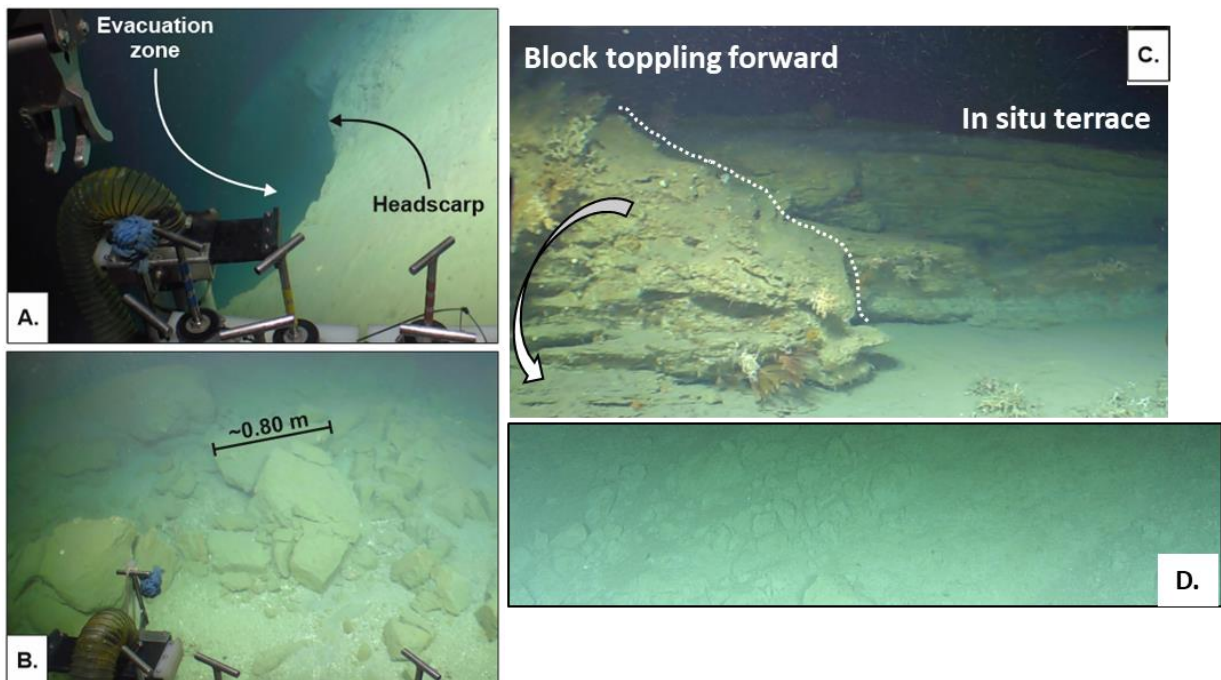

Fig 6.83 Different modes of failures/erosion observed during ROV dives in the Whittard canyon: A) retrogressive headscarp a few meters long showing 'fresh' morphology: B) debris with angular shape

of variable dimensions at the base of sub-vertical wall: C) in situ detached block toppling forward: D) Spalling debris

Debris at the base of the walls/terraces:

Talus slopes and boulder fields were observed at the base of sub-vertical walls and on terrace surfaces. Often, clasts had angular geometries and variable dimensions (from decimetre to metre; Fig. 6.83c, d).

Gullies and furrows along the slopes and walls

Observations from the ROV dives along the walls revealed important morphological features indicative of erosion such as gullies and furrows (see Fig 6.84), created through the downslope transport of material.



Fig. 6.84 Examples of scours, furrows along the walls, typically indicating erosive downslope processes.

Scours, furrows and ripple marks along the thalweg

Most of the ROV dives crossed the canyon thalweg in order to collect sediment cores and observe bedforms. Investigations of the thalweg revealed interesting bedforms indicative of current activity such as scour, furrows and ripple marks (see Fig 6.85).

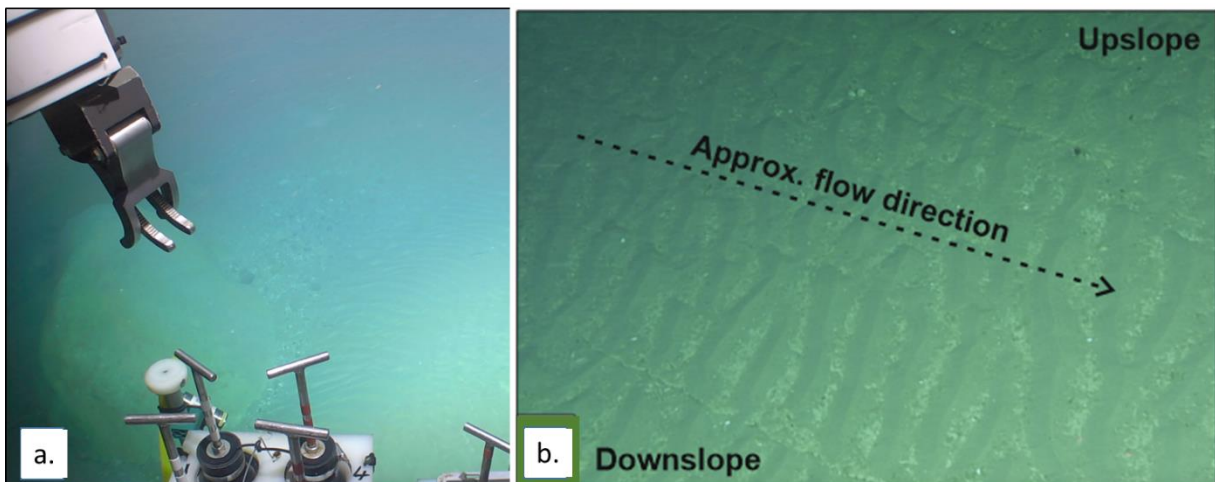

Fig. 6.85 Examples of different bedforms observed along the thalwegs of the Whittard Canyon during the ROV dives. A) obstacles and relative comet scours and b) sub parallel ripple marks with coarse lags (organic debris) deposited in the trough on the lee side.

Lithologies

A total of 22 samples (wrapped in 28 different units)(Fig 6.86 and Table 6.13) were collected in four different branches inspected with geological ROV dives during JC237. Primary lithologies encountered are shown in Fig.6.86.:

- Sandy clay – often forming a thin veneer over competent bedrock;
- Mudstone – often forming low (<2 m) terraces, with spalling and undermining common;
- Calcilutite – often forming high (>10 m) cliffs exhibiting ledges and overhangs. Discontinuities and structurally-controlled block failures present;
- Calcarenite – often forming terraces with discontinuities, structurally-controlled block failures, and undermining present; and
- Chalk – forming massive, high cliffs with occasional exfoliation surfaces.

In addition to the above, subordinate units of sandstone and limestone were encountered, as well as several instances of metamorphic clasts with no obvious origin, suspected to be ice rafted debris (IRD). Discolouration of exposed rock surfaces was noted in places, likely to indicated diagenesis has occurred in discrete zones.

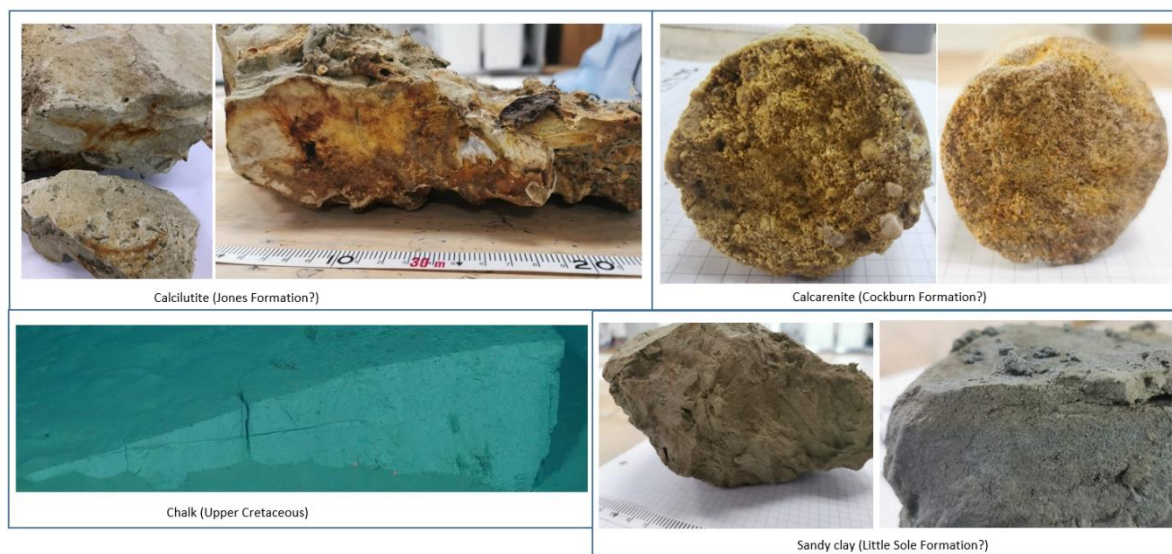

Fig.6.86 Examples of rock samples collected during ROV dives in the Whittard Canyon. The lithologies have been preliminary interpreted to be characteristic of the post-rift stratigraphic formations described in literature, deposited along the Celtic continental margin since Upper Cretaceous

Table 6.13 List of the 22 geological samples (Events) acquired during ROV dives in the Whittard Canyon, packed in 28 different bags

Count	Sample ID	Type	Description
1	JC237_Dive383_Stn09_Ev.7	Bag	Large sample bag - hard rock sample
2	JC237_Dive384_Stn012_Ev.1	Tube	Cardboard Tube - rock sample
3	JC237_Dive384_Stn012_Ev.2	Bag	Large sample bag - hard rock sample
4	JC237_Dive384_Stn012_Ev.4	Bag	Large sample bag - hard rock sample
5	JC237_Dive384_Stn012_Ev.5	Bag	Large sample bag - hard rock sample
6	JC237_Dive386_Stn017_Ev.1a	Bag	Small sample bag - mud sample
7	JC237_Dive386_Stn017_Ev.1b	Bag	Small sample bag - mud sample
8	JC237_Dive386_Stn017_Ev.1c	Bag	Large sample bag - hard rock sample
9	JC237_Dive386_Stn017_Ev.2	Bag	Large sample bag - hard rock sample
10	JC237_Dive386_Stn017_Ev.5	Tube	Cardboard Tube - rock sample
11	JC237_Dive386_Stn017_Ev.8	Tube	Cardboard Tube - rock sample
12	JC237_Dive386_Stn017_Ev.10	Bag	Small sample bag - mud sample
13	JC237_Dive387_Stn018_Ev.3	Bag	Large sample bag - hard rock sample
14	JC237_Dive387_Stn018_Ev.3	Bag	Large sample bag - hard rock sample (extra material)
15	JC237_Dive388_Stn022_Ev.5	Bag	Large sample bag - hard rock sample
16	JC237_Dive388_Stn022_Ev.8	Bag	Small sample bag - creamy white mud sample
17	JC237_Dive388_Stn022_Ev.9	Bag	Large sample bag - hard rock sample
18	JC237_Dive392_Stn046_Ev.1	Tube	Cardboard Tube - rock sample
19	JC237_Dive392_Stn046_Ev.7	Tube	Cardboard Tube - rock sample, main sample
20	JC237_Dive392_Stn046_Ev.7	Bag	Large sample bag - rock drill sample, extra fragments
21	JC237_Dive392_Stn046_Ev.8	Bag	Large sample bag - hard rock sample
22	JC237_Dive392_Stn046_Ev.9	Bag	Large sample bag - hard rock sample
23	JC237_Dive392_Stn046_Ev.10	Bag	Large sample bag - hard rock sample
24	JC237_Dive392_Stn046_Ev.10	Bag	Large sample bag - rock, extra fragments
25	JC237_Dive394_Ev.10	Bag	Large sample bag - hard rock sample
26	JC237_Dive394_Ev.11a	Bag	Large sample bag - hard rock sample
27	JC237_Dive394_Ev.11b	Bag	Large sample bag - hard rock sample
28	JC237_Dive394_Ev.12	Bag	Large sample bag - hard rock sample

6.7. eDNA & RoCSI (Susan Evans, Nathan Hubot)

During JC237, 2 RoCSI instruments were used to collect and preserve environmental DNA (eDNA) from the surface and deep ocean. In addition, water samples were collected using the CTD-Rosette and ROV and then filtered using a peristaltic pump in the lab. These samples will be used to validate the eDNA samples collected autonomously but also to assess the biodiversity in different regions of the Whittard Canyon and the Porcupine Abyssal Plain (PAP).

6.7.1. RoCSI

6.7.1.1. In Autosub5

A RoCSI was integrated into the nose of Autosub 5 prior to JC237. The sample inlet consisted of a long hose at the front right of the nose (Fig. 6.87) and the samples collected were either 1L or 2L depending on the mission duration. During the AUV missions, RoCSI received 12V from the Autosub5 and was programmed in the RoCSI node in OCS.

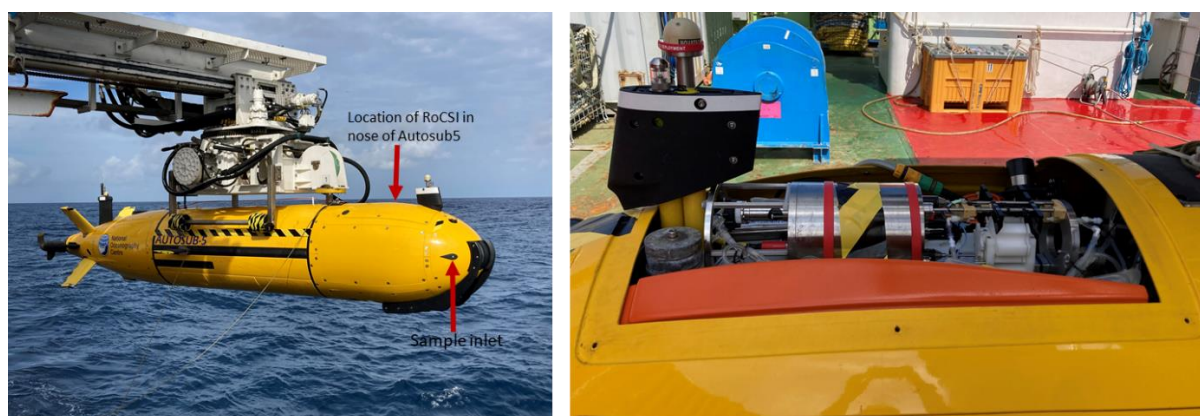

Fig. 6.87 RoCSI in the nose of Autosub5

0.22 μm Sterivex filter units were assembled into pre-labelled cartridge units by hand as close as possible prior to the deployment of the AUV. These were loaded into a 24 cartridge sampling belt which was loaded into RoCSI using the GUI to advance the magazine. The correct alignment of all the cartridge units was then checked at least twice. Fresh RNAlater preservative was prepared as close to deployment as possible. The plumbing was checked for leaks and RoCSI was pre-programmed using a GUI. After the AUV mission, the samples were removed from RoCSI, the cartridge units were disassembled, and the Sterivex units sealed. All samplers were then immediately transferred to the -80°C freezer. In total, 60 samples were collected autonomously using the Autosub5 from M37, M39, M41, M42, M44 and M45 (Table 6.14).

Table 6.14 Summary of RoCSI samples obtained using Autosub5 throughout JC237

Date	Mission number	Number of RoCSI samples
18/08/2022	37	2
21/08/2022	39	21
24/08/2022	41	5
26/08/2022	42	1
01/09/2022	44	21
02/09/2022	45	10

Troubleshooting and problems

After the first AUV mission, it became apparent that there was a problem with one of the magnetic couplings driving the sampling motor which had a deteriorated seal and rust had formed reducing the torque of the magnetic coupling. Whilst the RoCSI was still in the nose of the AUV, the sheath was removed and the old magnets were removed and replaced with new ones as well as new keeper plates. This improved the performance of the coupling but was deemed a quick fix and not an optimal solution for a submersible device, so in the end, RoCSI was removed from the nose of the sub and the

magnetic coupling was swapped for the one on the benchtop RoCSI requiring a disassembly of both devices. However, this procedure could only be done when there was a 24 hour period between missions. Following this swap, there was some adjustment of the alignment of the rods and end plate to improve the performance of the sample engaging and disengaging.

6.7.1.2. On the Bench

An additional RoCSI was set up on the benchtop in the Chemistry Lab (Fig. 6.88). The sample inlet tube was hooked up to the ship's underway water supply using a reservoir system that continually flushed with fresh water. During all of the ship's transits (Southampton to Whittard Canyon, Whittard Canyon to PAP, PAP to Whittard Canyon and Whittard Canyon to Southampton), RoCSI was used to autonomously collect and preserve DNA from the ship's continuous water supply. This was simultaneous to the deployment of the Continuous Plankton Recorder and the method is detailed below.

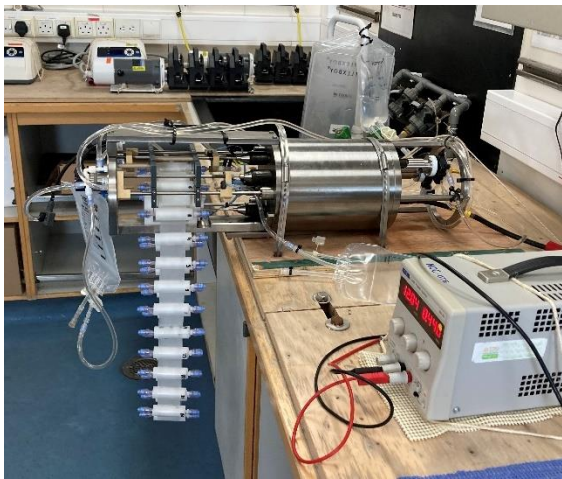

Fig. 6.88 Benchtop RoCSI hooked up to the RRS James Cook underway system

6.7.2. CPR

The Continuous Plankton Recorder (CPR) survey is the largest multi-decadal plankton monitoring programme in the world, operating since 1931. Water enters through an inlet aperture of 1.61 cm² and passes through a 270 µm silk filtering mesh (Warner & Hays, 1994). One sample corresponds to 10 nautical miles travelled by the ship. The aim of this work was to demonstrate that we see similar biodiversity metrics and community compositions using CPR vs genetic sampling across the shelf sea gradient and to see if we can validate eDNA diversity and abundance data from RoCSI deployed alongside the CPR.

The Continuous Plankton Recorder (number 27 with internals 27-0, 27-1 and 27-2) was deployed and towed from the stern of the RRS James Cook during JC237 during 4 transit's during the cruise (Southampton to Whittard Canyon, Whittard Canyon to PAP, PAP to Whittard Canyon and Whittard Canyon to the English Channel) (Table 6.15).

Table 6.15 CPR Tow number with tow length, location of deployment and recovery which took place when the ship was at 5 knots

Tow #	Deployment	Recovery	Date of deployment	Date of recovery	Tow length (nautical miles)
1	Nabs Anchorage (50° 33.6 N, 001° 00.3 W)	Whittard Canyon (48°09.1 N, 009° 35.3 W)	06/08/2022	07/08/2022	396.9
2	Whittard Canyon (48°19.66 W, 009° 38.3904 W)	PAP (48° 50.27 W, 016°27.12 N)	25/08/2022	26/08/2022	275
3	PAP (48° 40.82 W, 016° 23.97 N)	Whittard Canyon (48° 23.28 W, 010° 5.1682 N)	29/08/2022	30/08/2022	255.7
4	Whittard Canyon (48° 21.6 W 009° 48.8 N)	English Channel (49° 25.9 W, 005°03.61 N)	02/09/2022	03/09/2022	199

During all tows, the CPR was towed at an average ship speed of 10-12 knots and between 6-7 m depth. Simultaneously, genetic samples were collected autonomously using the benchtop RoCSI. 2L seawater samples from the ship’s underway supply were filtered through a 0.2 µm Sterivex™ filter unit and the nucleic acids preserved immediately with RNAlater (Ottensen et al., 2011) and then frozen at -80°C for genetic analysis. A sample was taken every 60 minutes. Corresponding 0.45 µm PES filtered seawater samples for nutrient analysis (NO₂, NO₂ + NO₃, PO₄, Si) were collected in triplicate every 2 hours. In total, 55 x 15 ml nutrient samples were collected for subsequent analysis.



Fig. 6.89 The Continuous Plankton Recorder on deck (left), and preparing the internal to load into the side of the CPR (right)

6.7.3. Water Sampling from CTD

Throughout the cruise, water was collected from the 10L OTE sampling bottles mounted on the CTD-Rosette from a total of 9 casts. In total, 96 samples were collected for eDNA analysis from a range of depths but the focus was on the deep water overlying the submarine canyon (Fig. 6.90, Table 6.16).

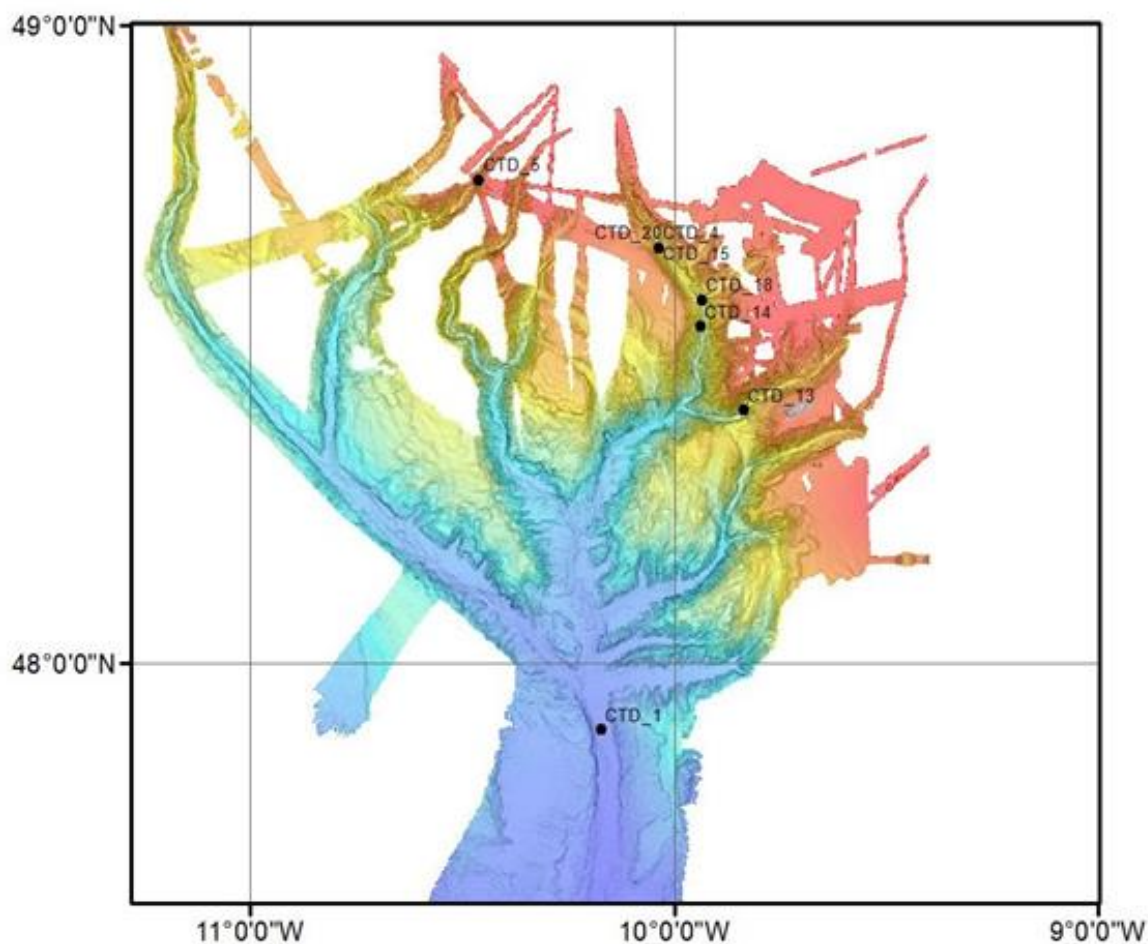

Fig. 6.90 Map of the CTD sampling stations where eDNA samples were taken

Table 6.16 Coordinates of CTD casts where samples for eDNA analysis were taken

Cast_ID	Latitude	Longitude	max depth (m)
CTD_1	47.894	-10.172	4031
CTD_4	48.653	-10.036	1300
CTD_5	48.759	-10.460	650
CTD_13	48.398	-9.835	1968
CTD_14	48.530	-9.936	2028
CTD_15	48.653	-10.035	1305
CTD_18	48.571	-9.935	1867
CTD_20	48.653	-10.035	1305

Following collection, 4L of water was immediately filtered in triplicate through 0.2 μm Sterivex™ filters using 2 peristaltic pumps in a laboratory (Fig. 6.91) which was kept free of sediment and fish biomass, with the exception of the chlorophyll-a max and the surface water (5 m) when only 2L was filtered in triplicate due to the presence of high biomass. The eDNA on the filter was immediately preserved using RNAlater preservative and then stored at -80°C onboard.



Fig. 6.91 Filtration setup in the lab using 2 peristaltic pumps.

6.7.4. Water sampling from the ROV

Water was also collected using ROV ISIS and then filtered in the lab for subsequent eDNA analysis. A 10 L OTE sampling bottle from the National Marine Equipment Pool was mounted on the forward left side of the ROV, and the bottle was triggered using the robotic arm which pulled a rope above the sampling tray (Fig. 6.92).

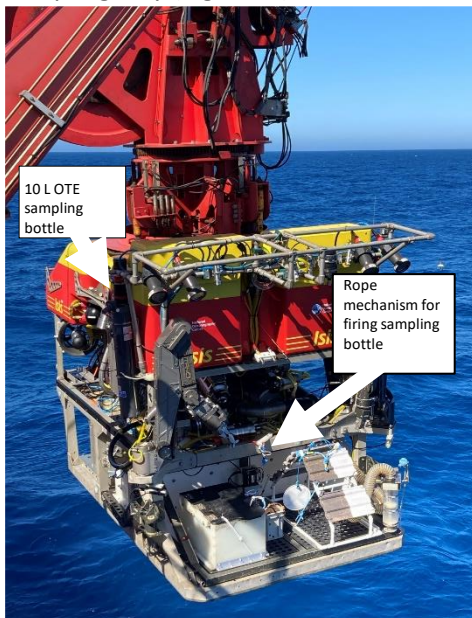

Fig. 6.92 Location of 10L water sampling bottle on ROV ISIS and the triggering mechanism.

In addition, water was also collected using the 6 small 1.2 L niskin bottles positioned on the right aft side of the ROV. The small niskins were fired under the control of the ROV and were closed one at a time. It took between 3 and 4 minutes to fire all 6 bottles under the control of the ROV pilot. The niskins on the ROV were fired in close proximity to regions of high biodiversity such as cold-water coral

walls and *Acesta* clam walls. Care was taken to avoid disturbing the sediment during sampling so typically the niskins were fired separately or at the start of a sampling event. In total, 81 samples were filtered (Fig. 6.93, Table 6.17).

Following the dive, seawater was collected from the bottles into 10L carboys using sterile tubing as soon as the ROV was secured on deck. The water was filtered in the same methodology as detailed above for the CTD samples.

Table 6.17 Coordinates with depth (m) where sampling bottles were fired

sample_ID	Latitude	Longitude	Depth (m)
ROV_01_Big	48.277	8.351	332
ROV_01_Small	48.277	8.363	334
ROV_02_Big	48.475	8.345	864
ROV_02_Small	48.468	8.353	1063.5
ROV_03_Big	48.472	8.334	843
ROV_03_Small	48.472	8.334	839
ROV_05_Big	48.352	8.284	1153.3
ROV_05_Small	48.362	8.277	696
ROV_06_Big	48.759	9.541	686.7
ROV_06_Small	48.765	9.540	560
ROV_07_Big	48.707	9.465	1114
ROV_07_Small	48.720	9.464	1029
ROV_08_Big	48.775	9.358	821.5
ROV_08_Small	48.770	9.359	850
ROV_09_Big	48.416	8.165	1492
ROV_09_Small	48.410	8.174	1609
ROV_10_Small	48.758	9.540	649
ROV_14_Big	48.369	9.963	3036.5
ROV_14_Small	48.375	9.955	3151

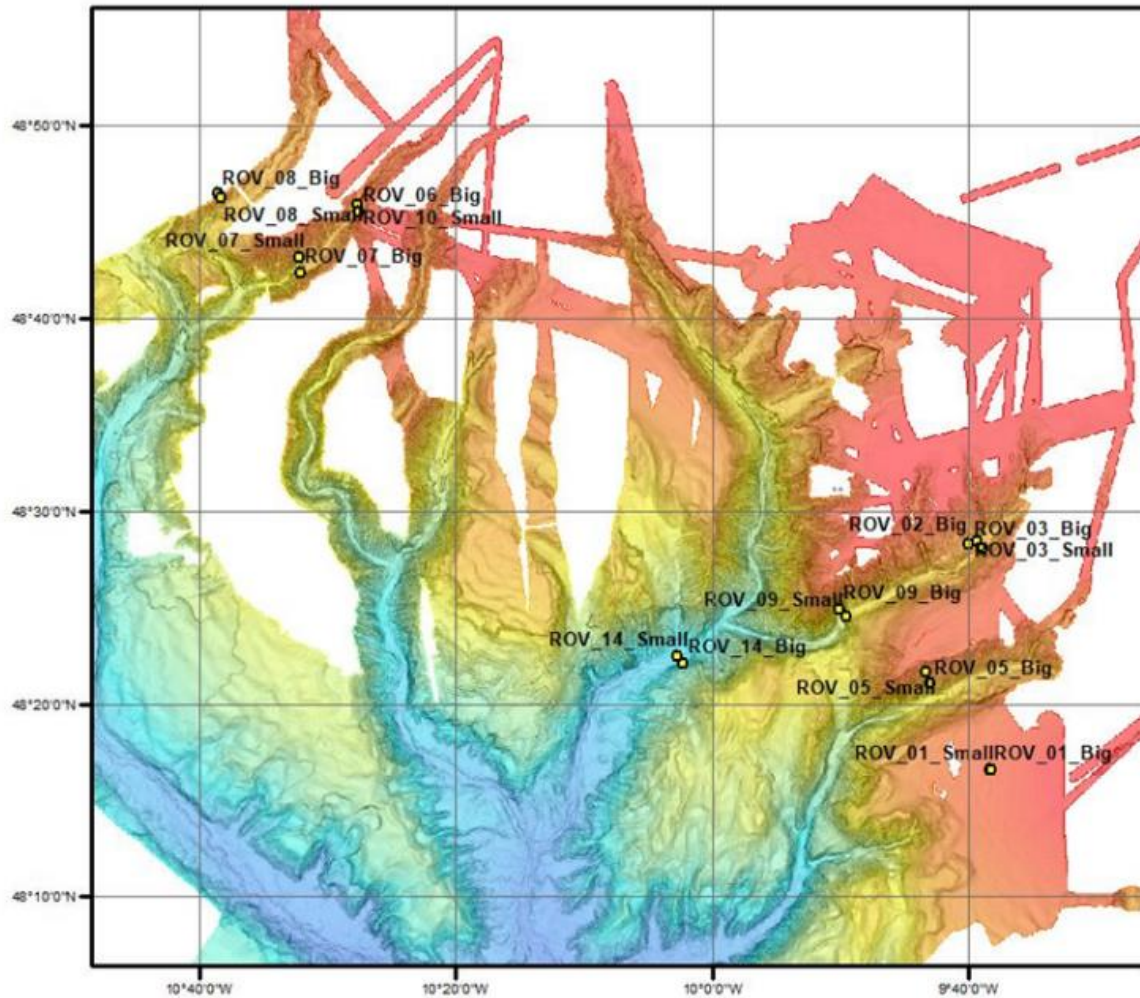

Fig. 6.93 Location of ROV dives in Whittard Canyon where eDNA samples were collected

Processing methodology

Once all the filter units and sediment samples are transported to the UK, eDNA in the samples will be analyzed in a dedicated clean lab using both DNA metabarcoding (multiple markers) and for targeted single species detection using quantitative PCR (qPCR) with species-specific primers. The specific qPCR assays conducted will be largely informed using information from the ROV video transects and based on species of interest and importance. For the metabarcoding approach, eDNA will be extracted from all samples and gene fragments will be amplified and sequenced (paired end) using an Illumina MiSeq system. DNA markers from four gene regions (cytochrome c oxidase I, 18S rRNA, 12S rRNA, and 16S rRNA) will be used to assess biodiversity in these samples. The raw sequence reads will be demultiplexed, quality filtered and then clustered into operational taxonomic units (OTUs). The OTUs will be denoised and taxonomically assigned to the best possible taxonomic resolution using several sequence databases.

Summary

In total, 342 samples for eDNA analysis were collected from the CTD-rosette casts, ROV dives and autonomously using RoCSI during AUV missions and the transits with the CPR.

The results from both multiple marker and single marker analysis will be used to assess biodiversity at the sample areas. Between sampling areas, the number of OTUs detected and number of unique OTUs for each metabarcoding marker will be compared to give an indication of deep-sea community composition at each sampling area. To validate the eDNA data collected autonomously, this will be compared to eDNA data collected using the CTD-rosette casts and ROV dives. Results from these samples will be discussed in the context of biodiversity assessment and also compared to eDNA samples collected by traditional rosette sampling.

6.8. Water column observations (Rob Hall)

6.8.1. CTD

Core water column observations were made with a SBE 911plus CTD rosette equipped with upward- and downward-looking RDI 300 kHz LADCPs. In addition to twin pumped temperature and conductivity sensors, the rosette was equipped with a SBE 43 dissolved oxygen sensor, a Chelsea Aqua 3 fluorimeter, a WETLabs C-Star transmissometer, a WETLabs ECO-BB turbidity sensor, and upward- and downward- looking Chelsea Biospherical/Licor PAR/irradiance sensors. Further details on the CTD and LADCP setup and data processing are included in Section 7.5.

6.8.1.1. CTD data processing

For preliminary analysis and cruise planning purposes, the CTD data were averaged (median value) in both 2 m and 8 m bins, the latter to match the resolution of the LADCP profiles (see Section 6.8.1.2). Down- and up-casts were binned separately to maximise the temporal resolution for internal tide observations. The average time of each bin was retained, rather than assuming a fixed time for the whole cast, to allow accurate harmonic analysis on each depth level. Cast-averaged CTD profiles (i.e. down- and up-casts combined) were also calculated for conventional plotting.

Derived properties, including conservative temperature, absolute salinity, and potential density, were calculated using the TEOS-10 Gibbs-SeaWater toolbox (<https://www.teos-10.org/software.htm>). Beam transmission (%) from the transmissometer was converted to beam attenuation (m^{-1}) using

$$A = -(1/r) \times \ln(T/100),$$

where A is attenuation, T is transmission, and r is the the path length (0.25 m) of the transmissometer.

6.8.1.2. LADCP data processing

The 300 kHz LADCP data were aquired in twenty five 8-m bins with 250 cm s^{-1} ambiguity velocity. The setup files for the master (downward-looking) and second (upward-looking) ADCP heads are shown in Section 7.5. For the majority of casts, the LADCPs were turned on/off before/after the cast, so that a single pair of data files were created for each cast, one file for the master ADCP (JC237_CTDXXXm.000, where XXX is cast number) and one file for the second ADCP (JC237_CTDXXXs.000). However, for the CTD/LADCP yo-yo (see Section 6.8.1.4) the LADCPs where turned on for the duration of the operation so that all eight casts were included in the same pair of data files (JC237_CTD006_013m.000 and JC237_CTD006_013s.000). The RDI software BSub was used to extract the data for each individual cast into a separate pair of data files (using the same naming convention as above), after the ensemble number at the time of minimum CTD pressure was identified using WinADCP.

The raw LADCP data were converted into profiles of absolute horizontal velocity using the velocity inversion method implimented with the LDEO_IX software package, first developed by Martin Visbeck

and maintained by Andreas Thurnherr (<https://www.ldeo.columbia.edu/~ant/LADCP/>). To obtain the most accurate absolute velocities, three auxiliary datasets were used:

- 1) The corresponding CTD profile was used to determine the depths of the ADCP heads and accurately calculate sound speed. For this purpose, CTD profiles were binned at 1 Hz after corrections had been applied and derived variables calculated. The filenames used have the form JC237_CTD_XXX_FilterP_AlignDO_CTM_Derive_1Hz_Strip.cnv
- 2) GPS data was used to constrain the barotropic component of the flow and calculate the local magnetic declination. As the CTD data files described in (1) include NMEA GPS location for each sample cycle, a separate GPS data file was not required.
- 3) 75 kHz shipboard ADCP data was used to constrain near-surface horizontal velocities. For this purpose, the 75 kHz narrowband 'contour' Matlab data files (os75nb_contour_uv.mat and os75nb_contour_xy.mat) were converted to required format by the function mkSADCP.m, included with the LDEO_IX package.

The LDEO_IX software successfully processed all 21 LADCP profiles and accepted the hour-long periods that the rosette was held at a constant depth for SAPS sampling. Deep velocities from cast 19 (PAP) should be treated with caution because the cast was not full-depth and thus there is no bottom tracking data to constrain near-bed horizontal velocities.

6.8.1.3. Individual CTD/LADCP casts

Thirteen individual CTD/LADCP casts were completed as unique stations (Table 6.18). These were primarily in the Eastern Limb of Whittard Canyon, but also one in each of Whittard Channel, Brenot Spur, the Western middle Limb, Explorer Canyon, and Dangaard Canyon. The latter (cast 21) was for calibrating hydrographic data from the DeepGlider (see Section 6.8.3). One CTD/LADCP cast was completed at PAP, although due to time constraints it was only to 4016 m (in a 4850 m water column).

Five casts included an hour-long period during which the rosette was held at a constant depth for SAPS sampling. For four of these casts (4, 5, 14 and 20) the SAPS sampling was at the maximum depth, so will not affect the processed CTD profile once the sampling period has been removed. However, during cast 17 the SAPS was run for an hour at 1508 m, partway through up-cast. Thus, there is a discontinuity in the pre-quality control binned CTD profile at this depth because the internal tide vertically displaced isosurfaces during that hour. For this cast only the down-cast data should be used. It should be noted however, that for all casts with SAPS sampling the down- and up-cast profiles of all properties are noticeably different due to internal tide displacement

Of the seven CTD/LADCP casts completed in the Eastern Limb, three (casts 4, 15 and 20) were at the same geographic location, the coral wall visited in 2009 and again in 2015. The objective of these casts was to monitor water column turbidity, a proxy for ROV visibility, which hampered dives in 2015. Due to the very narrow, steep-sided channel along the thalweg at this location, the rosette was only taken to 100 m above the seabed, just within the channel. The three casts, spread over 20 days, all showed elevated turbidity within the channel, up to $4\text{-}6 \times 10^{-3} \text{ m}^{-1} \text{ sr}^{-1}$ (see Fig. 6.94 for an example), but the thickness of the layer of elevated turbidity decreased with time. In comparison, three CTD casts from the same location during JC125 (using the same model of turbidity sensor) showed near-bed turbidity was around $2 \times 10^{-3} \text{ m}^{-1} \text{ sr}^{-1}$ in 2015. Thus, the measurements suggest turbidity in the channel was considerably higher in 2022 than 2015. This was confirmed by visual observations from the ROV. The four other CTD/LADCP casts along the thalweg of the Eastern Limb also showed elevated near-bed turbidity, but not of the same magnitude, only $1\text{-}4 \times 10^{-3} \text{ m}^{-1} \text{ sr}^{-1}$. In the Western Middle Limb of

Whittard Canyon, and in Explorer and Dangaard Canyons, turbidity was $\leq 1 \times 10^{-3} \text{ m}^{-1} \text{ sr}^{-1}$. The reason that turbidity levels are so high in the Eastern Limb and particularly elevated near the coral wall is unknown.

Table 6.18 Summary of CTD/LADCP casts taken during JC237

Stn no.	Cast no.	Latitude & longitude	Start & end date, time (UTC)	Max. depth (m)	SAPS depth (m)	Comments
002	001	47°53.613'N 10°10.380'W	8 Aug, 01:20 8 Aug, 04:41	4031		Whittard Channel 10 m from seabed
008	002	48°15.593'N 09°40.432'W	9 Aug, 16:07 9 Aug, 16:32	410		Brenot Spur 10 m from seabed
013	003	48°40.881'N 10°03.385'W	11 Aug, 14:57 11 Aug, 15:59	1194		Eastern Limb 11 m from seabed
015	004	48°39.198'N 10°02.152'W	12 Aug, 10:37 12 Aug, 12:59	1304	1304- 1298	Eastern Limb – coral wall 100 m from seabed
023	005	48°45.561'N 10°27.582'W	15 Aug, 09:51 15 Aug, 11:47	663	663	Western Limb 96 m from seabed
034	006- 013	48°23.870'N 09°50.127'W	19 Aug, 06:12 19 Aug, 18:58	1975		Explorer Canyon 13-h CTD/LADCP yo-yo (YoYo01): 8 casts, 50 m from surface, 50 m from seabed
039	014	48°31.776'N 09°56.174'W	21 Aug, 13:43 21 Aug, 16:26	2034	2034/ 2028	Eastern Limb 55 m from seabed
040	015	48°39.162'N 10°02.117'W	21 Aug, 18:33 21 Aug, 19:46	1306		Eastern Limb – coral wall Same location as cast 004 99 m from seabed
041	016	48°43.892'N 10°05.905'W	21 Aug, 20:59 21 Aug, 22:03	873		Eastern Limb 30 m from seabed
045	017	48°24.772'N 09°49.968'W	22 Aug, 18:40 22 Aug, 21:10	1788	1508	Explorer Canyon Close to YoYo001 60 m from seabed
047	018	48°34.273'N 09°56.110'W	23 Aug, 13:46 23 Aug, 15:12	1868		Eastern Limb 12 m from seabed
052	019	48°50.500'N 16°30.198'W	26 Aug, 12:29 26 Aug, 15:03	4019		PAP Water column depth: 4850 m
060	020	48°39.172'N 10°02.116'W	31 Aug, 10:55 31 Aug, 13:16	1305	1305	Eastern Limb – coral wall Same location as casts 004 and 015 99 m from seabed
064	021	48°19.196'N 09°47.457'W	1 Sep, 15:18 1 Sep, 17:04	2112		Dangaard Canyon DeepGlider calibration cast 9 m from seabed Primary CT (and oxygen) fouled at 115 m on down-cast

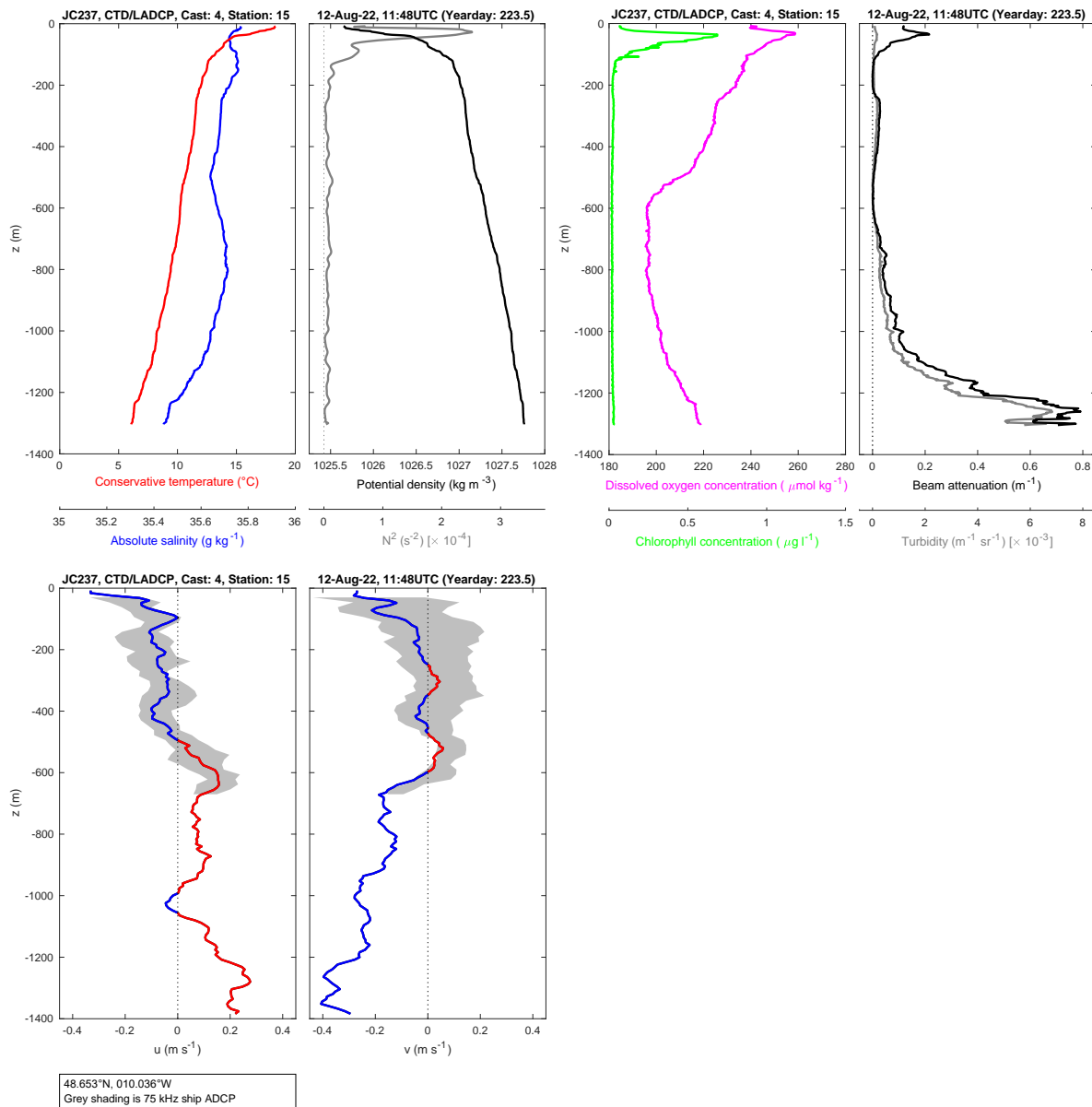

Fig. 6.94 Example hydrographic, dissolved oxygen, optical, and current velocity profiles: CTD/LADCP cast 4 (station 15). Note the elevated beam attenuation and turbidity beneath 1000 m.

6.8.1.4. CTD/LADCP yo-yo

Casts 6-13 (station 34) were part of a 13-hour CTD/LADCP yo-yo, where the rosette is profiled up and down through the water column repeatedly at the same station, without bringing it on deck. This method yields a timeseries of near-full-depth hydrographic and current velocity profiles over a complete semidiurnal tidal cycle, which allows tidal baroclinic components of pressure (p') and horizontal current velocity (\mathbf{u}') to be determined and thus the internal tide energy flux to be calculated as $\langle \mathbf{u}'p' \rangle$ (Nash et al. 2005), along with available potential energy and horizontal kinetic energy. To reduce wasted time spent approaching the bottom and surface, and thus increase the temporal resolution of the timeseries, the rosette was only taken to 50 m from the seabed and 50 m from the surface each cast cycle. Between the penultimate and final casts (12 and 13), the rosette was briefly brought to the surface to check that the water sample bottles were all still cocked. Then water samples were taken during the up-cast of cast 13. The target was to complete ten casts to 1975 m over the 13

hours, but unfortunately a heavy swell reduced the safe descent speed possible and so cycle time was longer than expected. We still completed eight casts over the 13 hours, more than enough to robustly resolve the dominant semidiurnal internal tide (M_2 , period: 12.42 hours). A visualisation of the potential density and horizontal current velocity timeseries from the CTD/LADCP yo-yo is shown in Fig. 6.95 and suggests the presence of a semidiurnal internal tide with a vertical isopycnal displacement amplitude of order 100 m.

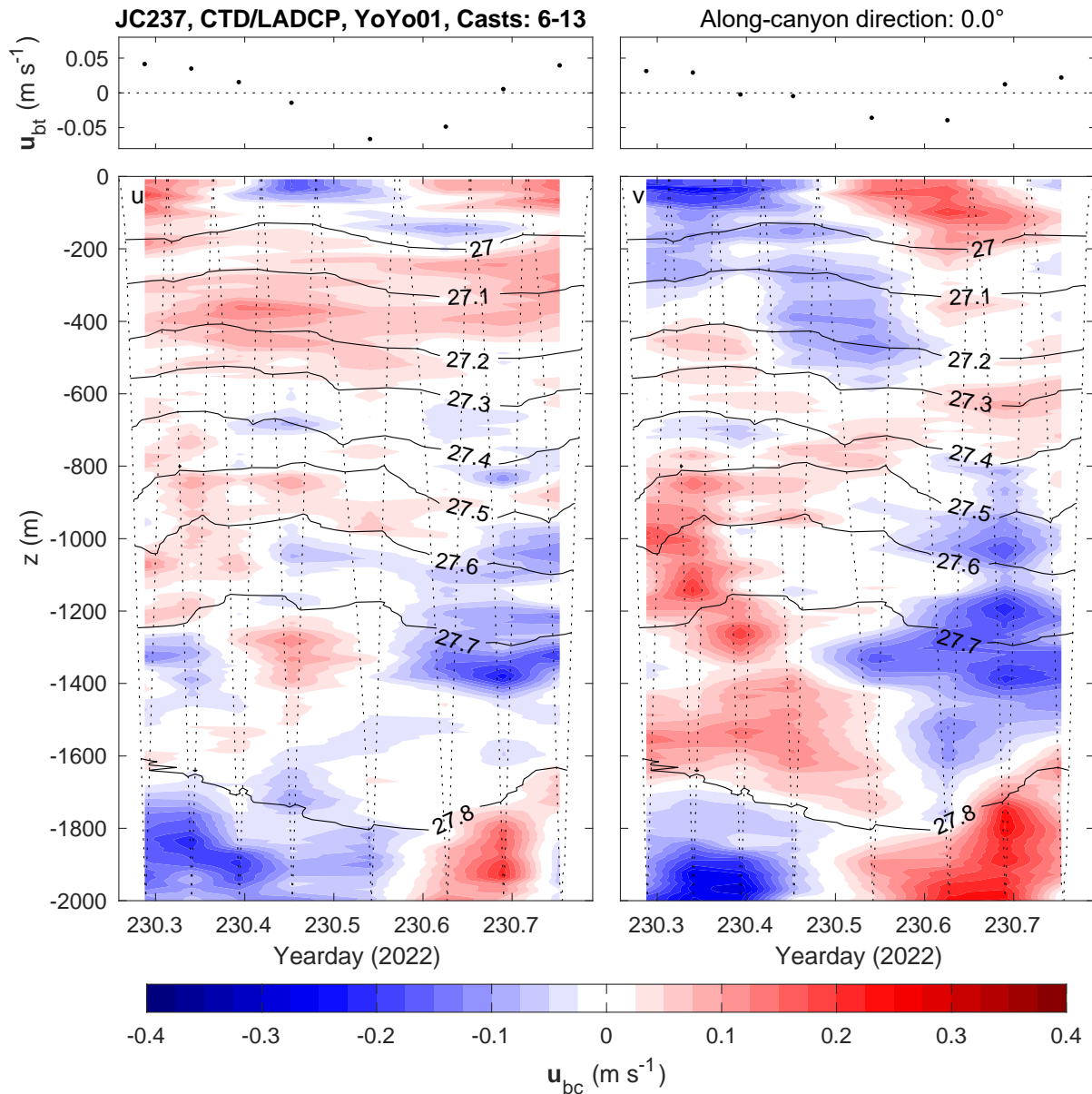

Fig. 6.95 Potential density and horizontal current velocity timeseries from CTD/LADCP YoYo001. Horizontal current velocity is split into barotropic (depth-average) and baroclinic components.

Note: While comparing CTD casts with previous cruises to Whittard Canyon, it was discovered that during JC125 (2015) incorrect calibration coefficients were used to process the fluorometer and turbidity sensor data. The correct calibration coefficients are shown below and the CTD casts have been reprocessed with these coefficients. The data were resubmitted to BODC on 05/05/2023.

Chelsea Aqua 3 fluorometer (SN: 08-2615-126)

Calibration date: 6 Aug 2014

V1: 2.2537

WETLabs ECO-BB turbidity sensor (SN: 169)

Calibration date: 9 Aug 2013

Scale factor: $4.011 \times 10^{-3} \text{ m}^{-1} \text{ sr}^{-1} \text{ V}^{-1}$

Dark voltage: 0.0924 V

6.8.2. Shipboard ADCP

The RRS James Cook's hull-mounted ADCPs, an RDI 75 kHz and an RDI 150 kHz, were run in narrowband mode continuously for the duration of the cruise using the University of Hawaii Data Acquisition System (UH DAS). Data quality was monitored daily using 5-minute ensembles in 16-m (75 kHz) and 8-m (150 kHz) bins, as output by UH DAS in NetCDF format. Data quality and range were good throughout the cruise, the 75 kHz typically yielding high-quality data to 600-700 m and the 150 kHz to approximately 300 m. The 75 kHz shipboard ADCP data was also used to constrain near-surface horizontal velocities during LADCP data inversions (see Section 6.8.1).

As the ship stayed roughly on-station during ROV dives, which typically lasted 12+ hours, the shipboard ADCP timeseries during these dives provided a good indicator of the tidal current structure in the upper layers of the water column. These timeseries show considerable semidiurnal baroclinic tidal variability within the canyon limbs (e.g. Fig. 6.96). During ROV Dive 387, at spring tide, the 150 kHz ADCP also resolved high-frequency (roughly 20-minute period) nonlinear internal waves in the upper 100 m of the water column, presumably generated at the shelf break. These waves were not apparent during ROV Dive 393 at a nearby location close to neap tide.

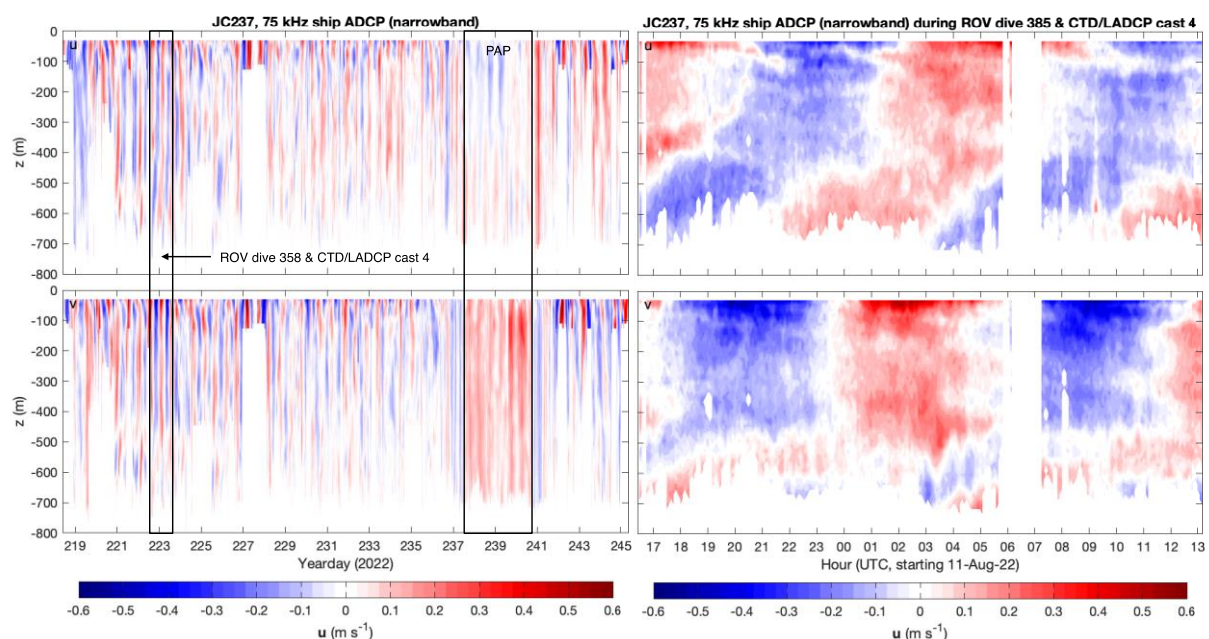

Fig. 6.96 75 kHz narrowband shipboard ADCP timeseries for the duration of JC237 (left panels) and in detail during ROV dive 385 and CTD/LADCP cast 4 (right panels).

6.8.3. Deep Glider

A Kongsberg DeepGlider (DG042) was deployed on 18 July 2022, from RRS *Discovery* during DY152, and operated in and around Whittard Canyon system until 1 September 2022, when it was successfully recovered during JC237. The glider was piloted remotely by a team at MARS (Stephen Woodward, Felipe Marques Dos Santos, and Michael Smart) with scientific direction from Rob Hall (UEA). The DeepGlider is a variant of the Kongsberg Seaglider that is pressure-rated to 4500 m and the plan for the mission was to extend existing hydrographic and internal tide observations, carried out in 2015 during JC125 using a 1000-m rated Seaglider, to full depth.

The sensor suite comprised of an un-pumped SBE conductivity-temperature cell (SN: 0292, an Aanderaa 4831F dissolved oxygen optode (SN: 453), and a WETLabs optical sensor (SN: 4746) measuring chlorophyll-a fluorescence (EX/EM 470/695 nm), CDOM (370/460 nm) and optical scatter at 700 nm. Unfortunately, the WETLabs optical sensor started to fail on dive 23 (22 July) due to suspected water ingress into the cable. After various sensor sampling rates were tried, the WETLabs was switched off for the remainder of the mission. Sensor sampling rates were kept constant from dive 33 (26 July) onwards and are outlined in Table 6.19.

Table 6.19 DeepGlider sensor sampling rates.

Depth range	SBE CT	Aanderaa oxygen	WETLabs optical
0-100 m	5 s	5 s	-
100-1000 m	15 s	30 s	-
1000-4500 m	15 s	60 s	-

For the first three days of the mission the glider dived to progressively deeper depths in deep water to the south of the canyon. Once safely diving to 2300 m, proper scientific sampling began (Table 6.20; Fig. 6.97). Two types of sampling scheme were used. The first was ‘virtual mooring’ mode, where the glider repeatedly dived over a fixed station. This is the preferred mode for internal tide observations because the dataset can be treated as a depth-timeseries. Although the dives are typically scattered several kilometers around the station, the horizontal wavelengths of low-mode semidiurnal internal tides are 10s-100s km so the fixed-point timeseries assumption holds. During this mission, nine virtual mooring (VM) stations were occupied for either 2 or 4 days each. VM numbers followed on from VM1-8 used in 2015, with stations VM2 and VM4 revisited. From VM2 onwards, two waypoints (5 or 10 km apart along the canyon limb axis and straddling the VM station) were used to keep the glider in deeper water. Both waypoints’ radius of arrival was set large (5 km) so that the glider’s target waypoint switched on each consecutive dive.

The second type of sampling scheme used was conventional hydrographic sections. These were oriented along three of the limbs of the Whittard Canyon system (ALS1-3). Some dives were ‘transit’ dives between sampling schemes.

On 1 September 2022 the glider was recovered to RRS *James Cook* using the standard recovery pole and noose method over the starboard gantry. The sea state (4-5) was marginal for recovery and while being winched aboard the glider impacted the side of ship, cracking the port wing. There did not appear to be any damage to the sensors or antenna. For calibration purposes, a full-depth CTD cast (cast 21) was started as soon as the glider was aboard. The calibration CTD cast was geographically close to, and approximately 9 hours after, the final deep dive of the mission (258).

6.8.3.1. Tidal aliasing

During VM9, the dive cycle time (8.5 h) was closely aliased to the semidiurnal internal tide so that most dives occurred at the same three phases of the tidal cycle. This is less than the four independent observations per tidal cycle required for a robust harmonic fit to be made. For VM10 the dive cycle time was increased to 9.25 h so that the dives were spread throughout the tidal cycle. For later VM stations, where the glider was diving to the full depth of the water column, tidal aliasing proved not to be a significant problem. This was because the variable canyon depth introduced a random element to the dive cycle time and so an aliased cycle could not develop. For the three shallowest VM stations, the dive cycle time was less than 3 h so the glider achieved the required 4+ independent observations each tidal cycle.

6.8.3.2. Altimeter issues

The DeepGlider has an altimeter that is used to sound for the seabed and decide on a safe depth to transition from the descent to ascent phases of the dive (known as apogee). There are several tunable parameters to account for different acoustic environments. During this mission the altimeter worked very well in deep water, often sensing true positive returns 300 m or more from the seabed. This proved problematic over the steep canyon bathymetry because the bathymetric depth can change by 10s of m during the final 300 m of the descent (order 500 m horizontal distance). To compensate for this, an unusually large safety margin (typically 100 m) had to be included to avoid the glider contacting the seabed.

In the upper reaches of the canyon there was a different issue. Because of the proximity of the 300-m deep continental shelf, the depth that the altimeter was turned on at was decreased from 500 m to 100 m. This resulted in repeated false positive returns and thus shallow (200 m) dives. We suspect that the false positives came from the surface (not the seabed) as the recorded depth and range of the positives were almost equal in each case. The issue was most problematic in the Eastern Limb, between VM2 and VM4 and between VM4 and ALS1. By the time the glider reached VM12 at the head of Explorer Canyon, the pilots had tuned the altimeter and settled on 400 m as the optimum depth to turn the altimeter on at. No further false positive returns were apparent.

Table 6.20 Summary of DeepGlider missions

	Nominal latitude & longitude	Dive no.	Start & end date, time (UTC)	Water depth (m)	Average dive cycle time	Comments
Deploy.	47°53.9'N 10°10.1'W	1	18 Jul, 10:32	4000	-	
VM9	48°12.9'N 10°14.1'W	21-32	21 Jul, 17:10 25 Jul, 23:33	3600	8 h 32 m	Confluence Diving to 2300 m WETLabs failure Tidally aliased
VM10	48°21.4'N 10°05.6'W	34-44	26 Jul, 10:36 30 Jul, 21:57	3200	9 h 46 m	Eastern Limb Diving to 2300 m
VM2	48°28.4'N 09°56.9'W	46-57	31 Jul, 06:56 4 Aug, 14:48	2300	8 h 39 m	Eastern Limb Diving to full depth Repeat of 2015
VM4	48°38.4'N 10°01.1'W	69-86	5 Aug, 18:49 9 Aug, 15:55	1400	5 h 10 m	Eastern Limb Repeat of 2015
ALS1	-	116-126	10 Aug, 20:33 14 Aug, 01:48	-	-	Eastern Limb Dives 121, 123 and 125 are shallow

VM11	48°24.5'N 09°49.2'W	135-146	16 Aug, 12:28 18 Aug, 21:39	1500	4 h 46 m	Explorer Canyon
VM12	48°29.9'N 09°36.1'W	153-174	19 Aug, 16:48 21 Aug, 20:01	900	2 h 20 m	Explorer Canyon
VM13	48°26.6'N 09°42.1'W	177-199	22 Aug, 01:42 24 Aug, 12:00	1100	2 h 32 m	Explorer Canyon
ALS2	-	202-211	24 Aug, 16:58 26 Aug, 01:53	-	-	Explorer Canyon
VM14	48°19.7'N 09°44.1'W	218-233	27 Aug, 04:24 29 Aug, 11:36	1600	3 h 27 m	Dangaard Canyon
VM15	48°21.9'N 09°35.6'W	236-253	29 Aug, 16:30 31 Aug, 14:22	1100	2 h 33 m	Dangaard Canyon
ALS3	-	254-258	31 Aug, 14:29 1 Sep, 08:31	-	-	Dangaard Canyon
Recovery	48°19.5'N 09°48.0'W	267	1 Sep, 14:18	1600	-	

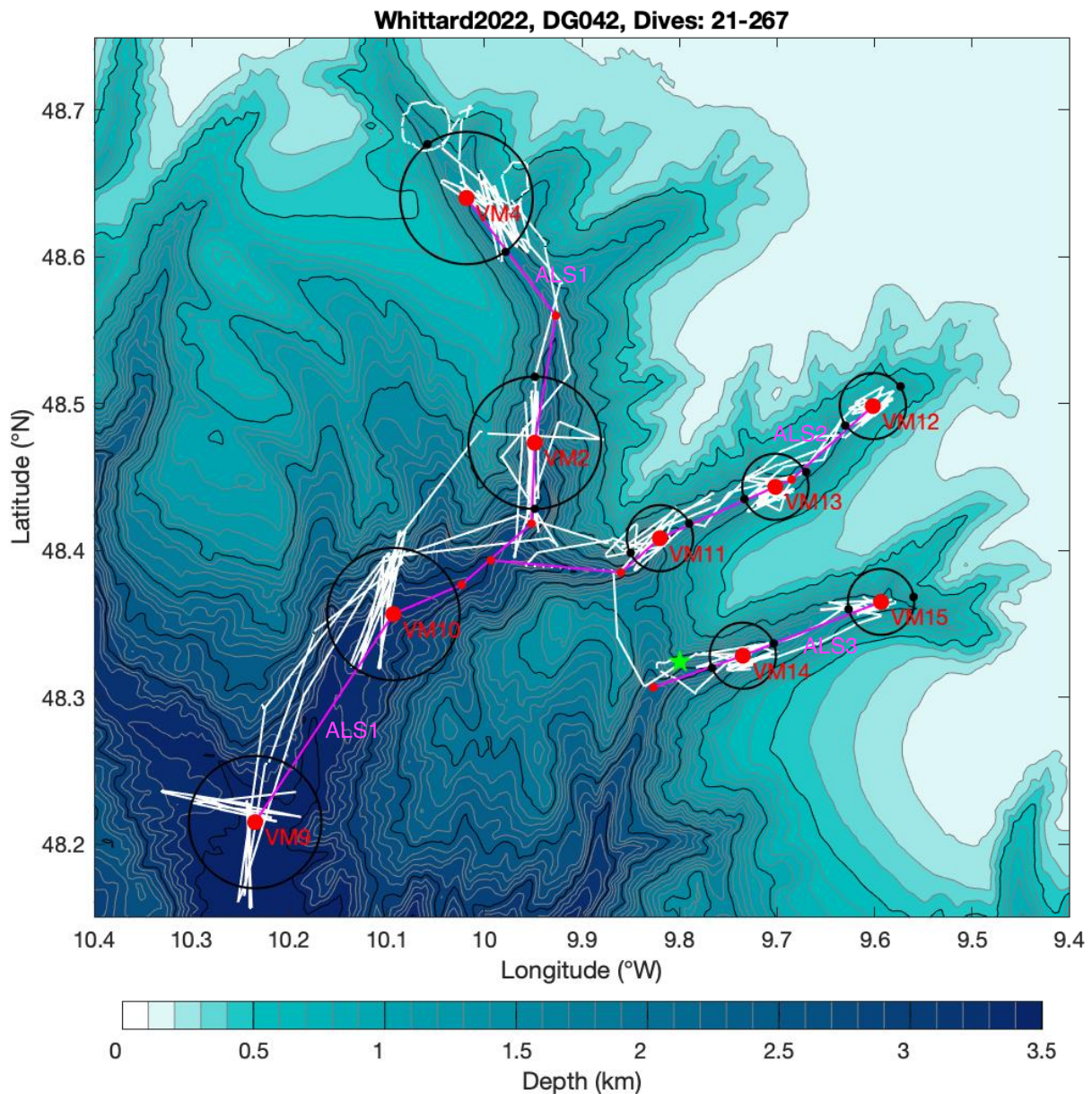

Figure 6.97 DeepGlider path (white line) and the locations of the virtual mooring stations (VM, large red dots) and along-limb sections (ALS, magenta lines). The first 20 dives, between deployment and VM9, are to the south of the region shown. The green star is the recovery location.

6.9. Outreach activities (Luis Greiffenhagen, Lisa Skein, Vikki Gunn)

During the cruise, scientific outreach was mainly done through the iAtlantic Blogpage of the cruise (link: <https://www.iatlantic.eu/jc237-expedition/jc237-expedition-blog/>). Lisa Skein (SANBI) and Luis Greiffenhagen (NOC) were responsible for the content. Onshore, Vikki Gunn (Seascope Consultants) was responsible for web design and uploading the blogposts.

In total, 16 blogposts went online, equalling a rate of every other day of the expedition. The aim of the blog was to communicate science and expedition experience to a broad spectrum of society. While complex topics were delivered in a language that is understandable for everyone, further material was

provided for readers that come from academia / marine science in particular (e. g. scientific papers etc.) through links within the text. A mix of 1) more “science heavy” posts (Oceanography etc.), 2) more personal, life-related posts (Food on board, Life on the bridge etc.), 3) equipment related posts and 4) general updates was produced, to give a broad overview of the cruise. Scientific facts were referenced. The style of reporting included interviews, little anecdotes, reviews of scientific topics and general reporting of events. As this cruise is interdisciplinary, the idea was to give different perspectives on the same study site (Biological, Geological, Sedimentological and Oceanographic).

Generally, a big focus was laid on producing engaging image/video material for the blog. The material included drone footage, ROV footage, and photos or data provided by the scientists / technicians on board. Videos were edited with Final Cut Pro. Before uploading, the drafts were reviewed by Veerle Huvenne (PI) and potential publishable findings from the cruise were excluded from the blogposts.

The blogpost topics included:

- *Setting Sail (introduction)*
- *Continuous Plankton Recorder RoCsi (equipment)*
- *General Update 1*
- *Canyon Sediments (science)*
- *AUV and Ocean floor Mapping (equipment)*
- *Food onboard*
- *Clam Wall (science)*
- *Oceanographer Interview (science)*
- *Wildlife Highlights (update)*
- *General Update 2*
- *Geology of the Whittard Canyon (science)*
- *Life on the Bridge (Interview)*
- *Porcupine Abyssal Plain (science)*
- *Life on a Research Ship*
- *ROV Pilot interview (life, equipment)*
- *Wrapping up / last update*

Further, the blog was shared via Twitter, LinkedIn, Email and in general to friends and families.

Blog Stats:

Country ▾	+	↓ Views	Users	Views per user	Average engagement time	Event count All events ▾
		29,488 100% of total	11,415 100% of total	2.58 Avg 0%	1m 03s Avg 0%	1,172,160 100% of total
1	United Kingdom	7,425	1,642	4.52	1m 36s	196,715
2	United States	4,530	2,960	1.53	0m 43s	145,836
3	Brazil	2,805	604	4.64	2m 00s	139,975
4	Germany	1,793	733	2.45	1m 01s	113,804
5	Spain	1,592	390	4.08	1m 41s	125,638
6	Portugal	1,289	394	3.27	1m 22s	21,659
7	France	980	349	2.81	1m 02s	41,637
8	South Africa	829	187	4.43	2m 14s	44,006
9	Canada	810	381	2.13	0m 53s	17,466
10	China	567	377	1.50	0m 20s	2,505

Twitter

Members of the cruise scientific team and MARS produced a variety of tweets in context with the #JC237 cruise hashtag. NOC and BGS were actively tweeting on the cruise as well. As of Sep 3rd, 44 posts related to #JC237 were online. A quick analysis showed that posts with the #JC237 hashtag were 161 times re-tweeted / shared and received more than 850 likes.

7. EQUIPMENT & SAMPLING REPORTS

7.1. Autosub5 Cruise Report

Operational Team: Matthew Kingsland, Richard Austin-Berry, Alberto Consensi, Conrad Ciaramella, Eoin O'Hobain

7.1.1. Introduction

Autosub5 (previously Autosub 2000 Under Ice Phillips et al. 2020) is a high-power work class 6m 2t AUV. It consists of a free flooded nose section containing sensors, a centre section of syntactic foam (the buoyancy) and batteries, the aft section is also free flooded containing navigation, additional sensors and the vehicle control in the form of twin thrusters and 4 independently actuated fins (Fig. 7.1). Its primary objective is to be launch from a ship such as the RRS James Cook for JC237 to image the seabed in high resolution by operating a multibeam echosounder used for topographic mapping, sidescan sonar used for acoustic imaging of the seabed, sub bottom profiler used to see what is in the first few meters under the seabed and high resolution camera systems. Other standard sensors include the ADCP for water column tracking and CTD (conductivity temperature depth). Specifically, for this cruise and upcoming cruises it has been fitted with the RoCSI eDNA sampler, a magnetometer and a single channel fluorometer. The vehicle has been designed by the NOCs Marine Autonomous robotics division to suit the needs of UK science with the primary goal being modularity so new experimental sensors can be accommodated.

Previous to JC237, Autosub5 had completed 7 weeks of testing in Loch Ness, Scotland. During the Loch Ness trials the vehicle's control system and integration of core payloads (MBES/Sidescan/ Camera) were tested from a shore facility in up to 220m of fresh water. Following the Loch Ness trials a 3 week sea expedition DY152 (July 2022) was carried out to fully commission the vehicle for science deployments. During DY152 Autosub 5's primary objectives were completed confirming it could be launched from a ship and dive to 4200m. Additionally it completed some initial science objectives by completing the Greater Haig Fras survey and an overnight multibeam at the very bottom of Whittard Canyon.

JC237 was the first science expedition of Autosub 5.

Autosub 5 was running an initial configuration of 6000m rated foam and five 5Kwhr batteries which allowed for ~100km ~24hour operations with all sensors running. Additional batteries and power saving upgrades will be added in 2023 to allow for a great endurance and deployment range.



Fig. 7.1 Picture showing Autosub 5 vehicle on gantry before launch.

7.1.2. Autosub5 Team

Table 7.1 – JC237 AUV team

Name	Surname	Institute	Role
Matthew	Kingsland	NOC/MARS	AUV (Autosub5) Engineer – Systems & Lead
Eoin	O’Hobain	NOC/MARS	AUV (Autosub5) Engineer – Software
Richard	Austin-Berry	NOC/MARS	AUV (Autosub5) Engineer – Mechanical
Alberto	Consensi	NOC/MARS	AUV (Autosub5) Engineer – Software
Konrad	Ciaramella	NOC/MARS	AUV (Autosub5) Engineer – Electronics

7.1.3. AUV Configuration

- Buoyancy 117N
- BG Stiffness 87.7Nm/Rad
- Wings Middle position @3°
- Autosub5 recovery line retention system with nylon springer lines
- 2m Springer lines
- 25m Onboard rope box recovery lines
- 30m LARS recovery lines
- Light flasher front single blink every 30 Seconds
- Light flasher Rear triple Blink every 1minutes
- Front Iridium Beacon H01-056 on 5min interval
- Aft Iridium Beacon H01-057 on 15min interval
- Avtrak Address 2407
- Marker 6 Address 2204

Table 7.1 - Autosub5 Sensor Fit

Sensor	Manufacturer	Operating parameters	Purpose	BODC Sensor #	Serial Number
2205 Sidescan Sonar	Edgetech	120kHz 400kHz	Dual frequency sides can imaging	TOOL1819	45563
2205 Sub Bottom Profiler	Edgetech	2-16kHz	Missions were either run on 2-13kHz 16ms sub-bottom chirp	TOOL1819	45563
WBMS Multibeam	Norbit	200kHz 400- 700kHz	Bathymetry mapping, water column data and snippet data. All Bathymetry collected was at 400kHz	TOOL1850	1706
WBMS Speed of Sound	Norbit		Speed of sound sensor		

WBMS Forwards looking Sonar	Norbit	200kHz 400- 700kHz	Obstacle avoidance system		1802
Seabird 9+ Dual CTD	Seabird		2 x Conductivity sensors 1 x pressure sensor 2 x temperature sensors	TOOL1508 TOOL0416 TOOL0417	09P69497-1124
CTD 9+ Dissolved Oxygen sensor	Seabird			TOOL0036	43C-2451
Downwards Cameras	NOC		3m Altitude camera surveys dual flash.	TOOL1201	
Chip scale Atomic Clock	Microsemi	1pps & NTP	Timing & triggering co-ordination	N/A	N/A
Sprint Nav 700	Sonardyne	600Khz DVL	Navigation & ADCP Data	TOOL1786	322108-001
BDRT Ecopuck	Seabird	Single Channel	Single Channel Fluorometer	TOOL0060	1560
ROCSII EDNA	NOC		24 EDNA sampler		N/A
1540 Magnetometer	Applied Physics Systems / NOC		Magnetometer	TOOL1818	0745

Table 7.3 – Ancillary equipment

Sensor	Serial	Purpose
Workshop container	NMFU 3274996	Container with spares and tools
Control Container	PSSU3687308	Container with QNAP & Piloting Equipment
LAWSON LARS	ASO-LG-6001	LARS(Launch & Recover system)

7.1.4. JC237 Summary

- 15 Deployments
- 861km of Science completed
- 700k of sidescan and multibeam collected. 3.8Billion Data points.
- >250,000 photos taken
- 60 ROCSII Samples taken
- Deepest mission to date of 4840m
- Longest mission 106.4km – 24hour and 20minutes
- Longest period spent piloting via iridium

7.1.5. Faults/Issues

There were a small number of issues and faults associated with this campaign, all faults are recorded in NOC's JIRA fault recording system with a unique number NOCSUB2KUI-xxx, those numbers are

recorded below. The faults and issues listed below are those relevant to operation and collection of science data on JC237:

- A cable fault discovered during mobilization lead to damage to one of the thrusters. The thruster port has a USB port for boot loading new firmware onto the unit the cable was found to have shorted those pins to the VBatt pins. This caused the SAM4E microprocessor in the thruster to become unresponsive. It is believed the cable was damaged during the final DY152 dive to 4200m. The cable & Thruster were changed out before JC237 left port. NOCSUB2KUI-501
- A piloting error on Mission 33 “Sandwaves” caused by not correctly setting one of the timeouts meant one leg was shorter than planned creating a hole in the sidescan survey data. NOCSUB2KUI-517
- Also on Mission 33 the submarine data shows one of the thrusters likely hit something toward end of the 15m altitude sidescan survey. The current on the Thruster went up while the RPM went down this is indicative of something potentially getting wrapped around the prop. The submarine responded correctly to the over current situation and turned off the thruster. The submarine continued on mission albeit slightly slower. NOCSUB2KUI-517
- During Mission 34 the Norbit Bathy system was set to the wrong time, this was a user/configuration error as one of the team checked the bathy setup with the Norbit GUI, the GUI unfortunately reset the NPT sever settings in the unit. The data was later corrected in post processing and the config file was update to prevent this in the future. NOCSUB2KUI-526
- During the Aesta wall M35 – M38 dives several false DVL pings caused unnecessary aborts due to the submarine thinking it was under its minimum altitude. The under minimum altitude abort is a safety featured designed to stop the submarine from crashing into the seabed. The false pings created by the DVL are thought to be a combination of high turbidity and flow rate experienced in the canyon. The DVL onboard Autosub 5 registers a response if it deems 3 of the 4 beams to be good, during the mission the submarine was flying besides a 300m high cliff at ~50m away thus two of the DVL beams were getting a correct response. It then only took 1 extra beam getting a false return at close range due to the turbidity for the submarine to register it was under its minimum altitude. The NOC is looking at alternative ways to analyse the PDO data to stop this from happening again. NOCSUB2KUI-526
- During M37 dive phase a dive safety contingency was unnecessarily triggered causing the submarine to surface. This was later traced back to the rough weather on the surface making the submarine think it had dived twice. The ship had already moved on and Launched the ROV thus the submarine was re-tasked via iridium satellite communication to complete M37. NOCSUB2KUI-546
- During the M37 recovery on 18/08/2022 the forward Iridium Beacon came loose and was lost during recovery. We believe during the grappling recovery procedure one of the grapples was caught on the forward iridium beacon making it come loose. NOCSUB2KUI-544
- During Recovery of M41 24/08/2022 one of the actuators was damaged and was subsequently changed out. The recovery was being conducted by a trainee while supervised, the recovery went fine other than a small error at the end where the rear of the submarine was placed onto its blocks before the front causing one foil to come into contact with structure and put too much force through an actuator. NOCSUB2KUI-557
- Mission 42 the port side thruster serial number 04 (the same one from Mission 33 NOCSUB2KUI-517) gradually overheated and switched off 17 hours into the mission. This can primarily be attributed to the port thruster working harder than the starboard, work needs to be done on the thrusters’ internal feedback loops to stop one working harder than the other. NOCSUB2KUI-563
- During the recovery of the submarine from Mission 42 27/08/2022 a piece of lifting equipment broke. Specifically, a boss hook, it was not lifting the submarine at the time it was pulling the

submarine towards the LARS. The hook does not take load during the lifting operation it does however see load when pulling the submarine toward the ship. NOCSUB2KUI-546

- During the same Mission 42 recovery the forward payload tube experienced a short /circuit on its main Vbatt power input line. The power tube detected the short circuit and turned off the payload tube. The forward payload tube was subsequently swapped out overnight with the submarine returning to operations the next day. No data was lost. After post mission analysis the fault was traced back to a press-fit back plane connector which shorted, this was a manufacturing fault which was likely exasperated through the shock and vibration when using the submarine. NOCSUB2KUI-559
- During Mission 44 the Camera flashes stopped working, this was attributed to a failed cable shorting the camera flash trigger line to sea water likely due to the depth experienced on Mission 42 and 43. The cable was changed and mission 45 was run successfully. NOCSUB2KUI-570

7.1.6. Mission Summaries

Table 7.4 Mission summaries

Mission Number	Start Time	Start Date	Finish Time	Finish Date	Distance	Start Lat	Start Long	Notes on Mission & Data
A5M31	15:50	08/08/2022	07:58	09/08/2022	71.0km	48.245940	-9.708051	Repeat of Autosub6000 M89 Mini Mounds, 15m 410kHz Sidescan and 3m Camera survey. The submarine completed the sidescan but under min altitude aborted during the camera survey due to the rough terrain
A5M32	14:54	09/08/2022	18:30	09/08/2022	16.0km	48.262780	-9.665967	Repeat of the previous AS5M31 camera survey with upgraded control loop settings, collected some required camera images. The Forward looking sonar was also turned on to gather obstacle avoidance data.
A5M33	13:40	10/08/2022	12:15	11/08/2022	81.7km	48.752624	-9.839031	Repeat of Autosub6000 M88 Sandwaves mission at the top of the canyons. 400khz 75m Multibeam, 15m 410khz sidescan and camera images. Multibeam and sidescan successfully collected but the submarine under min altitude aborted during the camera survey due to the rough terrain.
A5M34	15:40	12/08/2022	10:15	13/08/2022	88.3km	48.487828	-9.619217	Explorer Canyon 400kHz multibeam and 120kHz Sidescan. All Data successfully collected.
A5M35A	11:24	14/08/2022	17:40	14/08/2022	30.2km	48.753320	10.442660	Acesta Canyon 400kHz multibeam and 120kHz Sidescan mission ended after 6 multibeam legs due to an under min alt abort. It is believed this was an artefact in the DVL and the submarine did not actually get close to the seabed.
A5M35B	18:30	14/08/2022	10:00	15/08/2022	10.0km	48.753320	10.442660	Due to the ROV already being in the water 10km from the Submarine, the submarine was driven back to the ship and held 2km off the ship until the morning

A5M36	14:20	17/08/2022	15:15	17/08/2022	3.3km	48.764421	-10.45679	Acesta Canyon 400kHz multibeam and 120kHz Sidescan mission ended due to an a false set of DVL pings causing an under min alt abort
A5M37A	17:27	17/08/2022	18:25	17/08/2022	4.0km	48.755906	10.467052	Acesta Canyon 400kHz multibeam and 120kHz Sidescan mission ended after 30 minutes due to dive timeout software bug
A5M37B	19:56	17/08/2022	22:32	17/08/2022	18.5km	48.755906	10.467052	Mission AS5M37A was subsequently split into 3 chunks so it could be run via iridium which has a maximum of 7 tracks.
A5M37C	22:32	17/08/2022	05:00	18/08/2022	34.1 km	48.755906	10.467052	Mission AS5M37A was subsequently split into 3 chunks so it could be run via iridium which has a maximum of 7 tracks.
A5M37D	05:00	18/08/2022	08:04	18/08/2022	18.0km	48.755906	10.467052	Mission AS5M37A was subsequently split into 3 chunks so it could be run via iridium which has a maximum of 7 tracks.
A5M38	13:42	18/08/2022	15:55	18/08/2022	9.0km	48.763417	10.458255	Acesta Canyon 400kHz multibeam and 120kHz Sidescan mission ended after 1.5/3 laps of the canyon due to an under min alt abort created by a false DVL ping
A5M39	16:02	20/08/2022	08:50	21/08/2022	75km	48.413707	-9.674823	Alternative mini mounds site 50m 400kHz multibeam 15m 410kHz Sidescan and 3m Camera survey. Vehicle struggled with terrain at 4m and under min alt Aborted
A5M40	09:00	22/08/2022	09:23	23/08/2022	106.1km	48.658513	10.031802	Coral wall canyon 400kHz multibeam and 120kHz Sidescan all data collected successfully
A5M41	13:29	24/08/2022	15:47	24/08/2022	9.1km	48.415388	-9.678955	Alternative mini mounds site repeat of the AS5M39 4m Camera survey. Vehicle struggled with terrain at 4m and under min alt Aborted
A5M42	15:32	26/08/2022	14:28	27/08/2022	78.0km	48.847152	16.534510	24Hour camera survey at PAP 4840m with 410kHz sidescan at 3m all data collected successfully
A5M43	15:54	28/08/2022	16:08	29/08/2022	97.2km	48.694360	16.403488	24Hour camera survey at PAP 4840m with 410kHz sidescan at 3m all data collected successfully

A5M44	15:15	31/08/2022	12:55	01/09/2022	95.0km	48.562692	-9.754352	Alternative ROCSI mission 75m 400khz multibeam, 15m 410kHz sidescan and 4-5m camera survey. Cable failure on the camera trigger line meant flashes did not operate
A5M45	13:08	02/09/2022	17:02	02/09/2022	16.8km	48.546728	-9.806878	A5M44 camera survey repeat to gather the camera images which failed in M44. Camera images collected successfully.

7.1.7. AUV Data

7.1.7.1. Hard Drive Structure

At the end of the cruise a hard drive was presented to the PI containing all the collected data. This data is also hosted on the NOC network and is available from the MARS AUV ops team. The final copies will be uploaded to the British Oceanographic Data Centre (BODC).

The file structure contains 15 folders one for each mission with the relevant mission number. Within each folder is 3 additional folders.

7.1.7.1.1 The mission management folder

This folder contains all the planning information which was carried out before and after the mission. There is a document explaining the planned mission before it is carried out and another document explaining how the mission went. On top of that there is a .JSON file which is a download of the mission itself from the MARS command and control system. This contains all the submarine mission parameters including but not limited to mission version, way points, timeouts, pitch angles, altitudes, depths and speeds. Other things which may be found in this folder is RoCSI programming files, initial data analysis and pre-launch checks.

7.1.7.1.2 The Post processing folder

This folder contains all post processing of the Raw data into standard file types, within this folder you will find initial decoded and parsed data.

After each mission the submarine creates an engineering log CSV file with 1 second updates from all devices. This CSV is used to create engineering plots (see MATLAB Plots folder). Using this CSV the AUV team generate ~70 plots which describe what the AUV did during the mission. The .YAML file is meta data to help decode the .CSV file however the column headers in the .CSV are self explanatory.

The below plot (Fig. (7.2)) is an example from AS5M40 the Coral wall canyon Multibeam the trajectory Autosub5 took viewed in 3D. The plots are saved in both .fig and .png format.

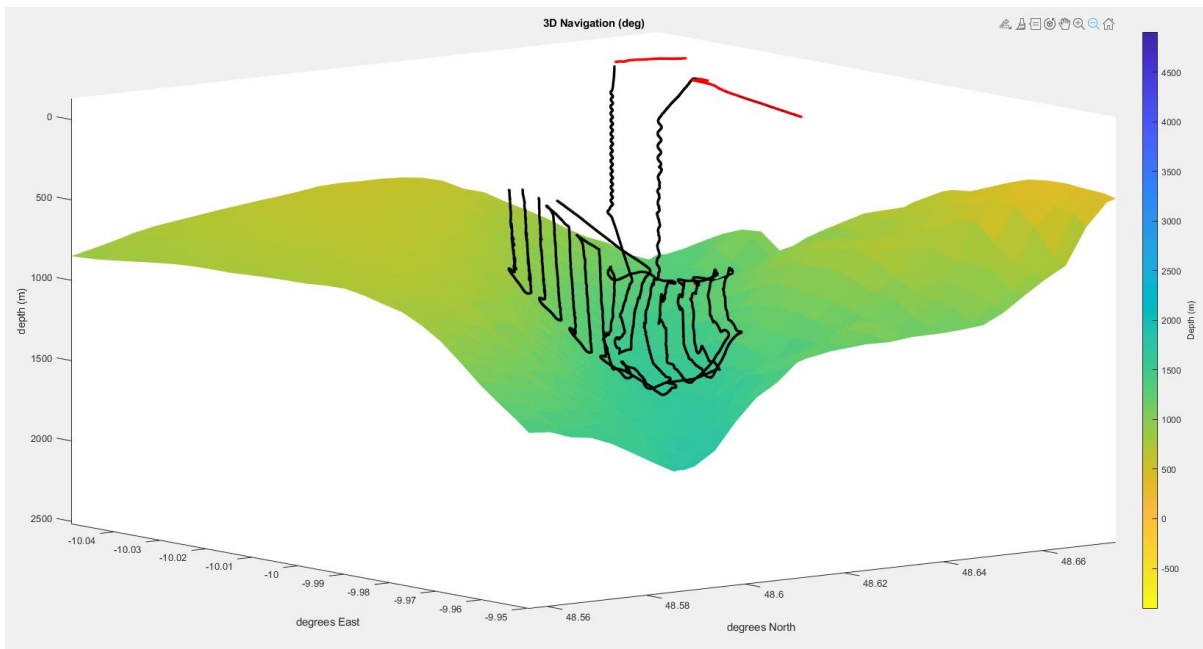

Fig. 7.2 Example of AUV track plot

7.1.7.1.3 The Pre processing folder

This folder contains all the raw logs from any device on during the mission (Fig. 7.3). There is effectively a folder per hard drive logging data including in all folders will be Sprint Nav Raw logs, DVL Raw logs and the MARS on-board control system logs. Additional folders which may appear depending on mission are RAW Camera image and RAW Edgetech 2205 data.

The OCS logs folder contains a copy of all the logs generated from the last time the submarine was booted to when it was recovered. Thus there might be a prolonged period of time in the logs before the mission starts. Most of the data is encoded binary, however there are some files - specifically the sensors_raw_data folder - which are human readable.

The raw sprint Nav logs require Sonardyne JANUS to decode them. while the Syrinx DVL logs require a suitable .PDO parser.

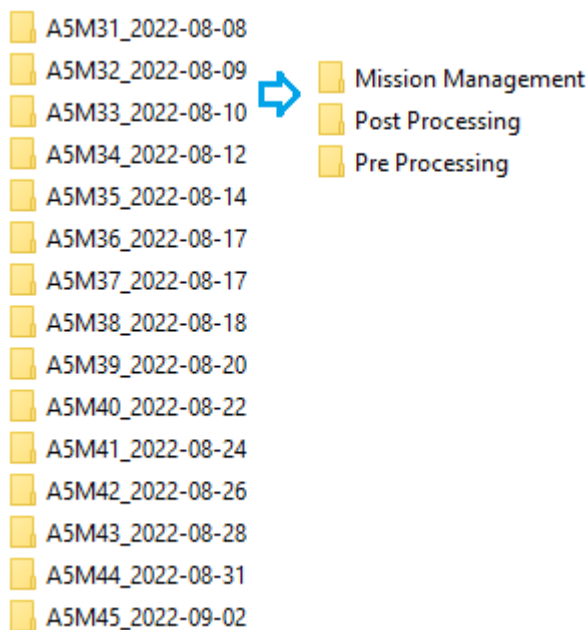

Fig. 7.3 Folder structure for Autosub5 datasets

7.1.7.2. Triggering

Every acoustic device on the submarine is triggered to be in sync with each other, thus reducing the interference between devices. The trigger rate is set around the highest priority data, for example if the low frequency 120khz side scan is the primary data product the ping rate is slowed down to 2hz to allow the maximum range data to be collected. If a 3m camera survey is the primary operation the ping rate is set to 6Hz this allows the vehicle to detect the bottom from ~130m away but also have a rapid update rate while at 3m. The exact triggering setting used in each mission is in that mission's summary.

7.1.7.3. Timing

All devices on the submarine are synchronised to a NTP server running on the aft payload tube. This NTP server gets its time from GPS and is stabilized by a 1pps coming from a chip scale atomic clock embedded in the aft tube. The 1pps is fed around the system to devices to increase the accuracy of their timing.

7.1.7.4. **Sidescan & Sub bottom profiler Edgetech 2205**

The sidescan data is saved in two locations on the submarine as a .JSF file. One set of .JSF files are stored on the submarine's main computer hard drive and these are not broken up in anyway and can be found in the OCS Logs folder. The second set of .JSF files are stored on the Edgetech 2205 itself and are broken up by track. These can be found in the Edgetech folder. The vast majority of the missions run during cruise used the 2-13kHz 16ms sub-bottom chirp however the exact setting for each mission can be found in the mission planning/summary.

7.1.7.5. **Multibeam**

The Nortek Multibeam produces 3 main files: a Multibeam file, a sidescan/snippet data file and a water column data file. In the raw folder these files are stored as a raw binary output from the submarine and have to be converted to .S7k and merged with the navigation data as a post processing exercise which is what can be found in the post Processing folder.

All the missions with multibeam on were run with the 400kHz 80kHz bandwidth at maximum power.

The multibeam also has the speed of sound sensor embedded with it, this data is recorded in the 3 multibeam files but can also be found in the Engineering CSV.

Within the files you can find the follow 7K Records:

7000 – System Configuration Data

7004 – Beam Geometry Data

7027 – Bathymetry Data

7007 – Sidescan Data

7042 – Water column Data

7610 – Speed of Sound data

Note 7028 & 7058 snippet and multispectral backscatter strength data will be enabled for future expeditions.

7.1.7.6. **Navigation data**

There are several sources of navigation data being created on the submarine. The main two are the Localizer and the Sprint Nav. The Localizer is a navigation algorithm created by MARS and was the primary navigation for all missions on JC237. The Sprint Nav data is being logged and then as a post processing exercise is re-processed in JANUS to create a more accurate Navigation file which gives the best quality navigation for the multibeam data. That navigation data is now merged by MARS into a .s7k file.

7.1.7.7. **Seabird 9+ & BDRT Ecopuck Data**

The >10hz seabird 9+ data is stored in a standard seabird stand-alone file found in the Post Processing CTD folder. A reduced data set can also be seen in the engineering CSV data.

Likewise the Fluorometer data is stored in a standard file format but a reduced data set can also be seen in the engineering CSV data.

7.1.7.8. ADCP & DVL data

The 600kHz Sonardyne Sprint Nav alternates pings between collecting DVL data and ADCP data. The Ping rate of the submarine varies between 2hz and 6Hz depending on the data being collected. This means we get at least 1 DVL and 1 ADCP ping per second.

The data is logged in two places: both on the submarines main computer and the on the Sonardyne Sprint Nav itself. In both locations it is stored in a PDO format which can be opened in WinADCP. On JC237 the first couple of missions had 12 very large 8m bins size. This was reduced to 150 bins at 0.5m however the data was patchy and thus for the majority of the deployment the system was set to 75 1m bins. The exact setting for each mission can be found in the mission summary section.

7.1.7.9. Camera data

There was only one camera on JC237 which was pointed directly down in the nose of the submarine. When on, the camera was taking photos at 1Hz, the images were stored in RAW format which can be found in the pre-processed folder. The settings needed to open them in InfranView are 2448 x 2048 set to 8 bits per pixel. A BlueGreen Bayer Pattern corrects the colours for the light absorbed by sea water. A selection of images have been batch processed into JPEGs found in the post processed folder.

7.1.7.10. RoCSI eDNA Sensor Data

The RoCSII eDNA sensor was triggered to take X number of samples once it reached a specific predetermined depth. All the data around where RoCSI took samples is stored in the Engineering CSV and can be viewed visually in the MATLAB plots (Fig. 7.4). Examples below:

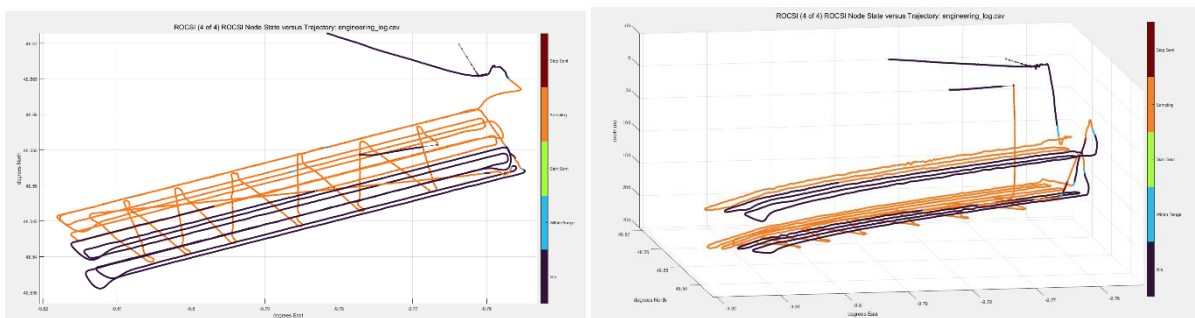

Fig. 7.4 Examples of track plots showing RoCSI sampling

7.1.8. Missions

7.1.8.1. Whittard Canyon Autosub Work areas

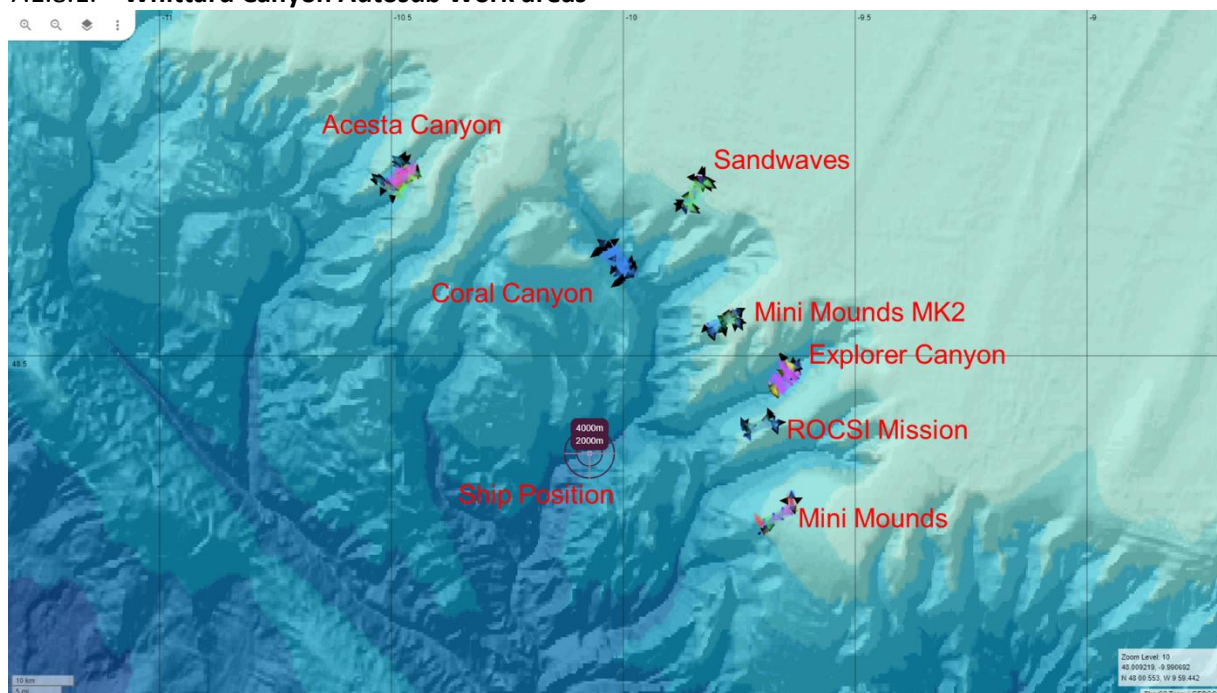

Fig. 7.5 Overview map of Autosub5 Missions in Whittard Canyon

7.1.8.2. Autosub5 M31 Mission Summary

7.1.8.2.1 Mission Stats

Table 7.5 Details of mission A5M31

Mission Identifier	A5M31
Start Time	08-Aug-2022 15:48:06
Time Elapsed	16.8014 Hrs
Distance Travelled	70.7677 Km
Start Coordinates	48.2556 deg N, -9.698 deg E
End Coordinates	48.2839 deg N, -9.652 deg E
Max Depth	570.3594 meters
Minimum Altitude Recorded	0.2m
Start Battery Voltage / Start State of Charge	57.994V / 97.5%
End Battery Voltage / End State of Charge	50.79V / 31.5%

7.1.8.2.2 Mission Plan Description

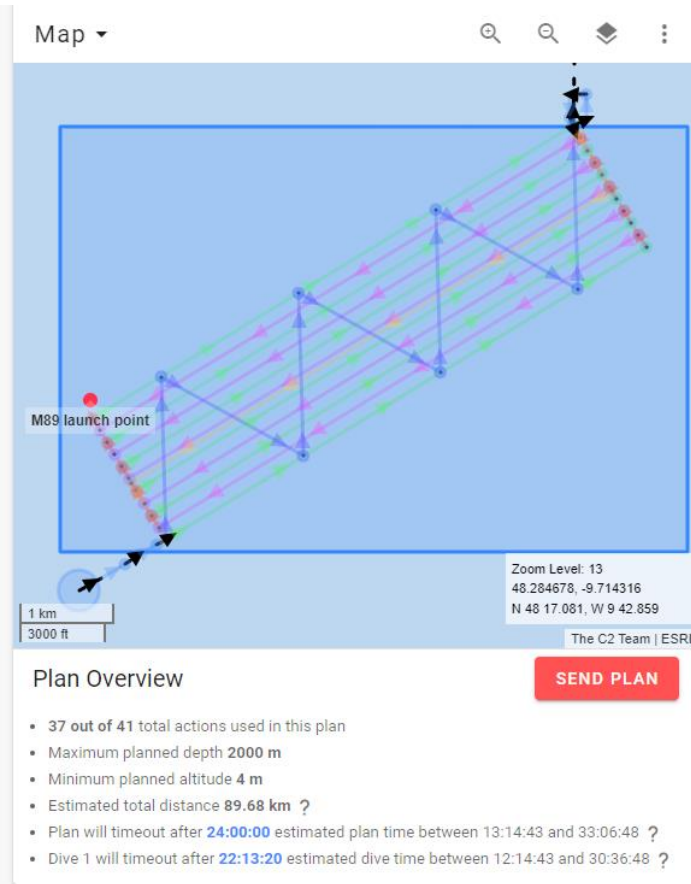

Complete the “mini mounds” survey previously completed by Autosub 6000 M89 in 2015 on JC125. This mission consists of an initial 11 x 5km long high frequency side scan lines at an altitude of 15m followed by camera images at 4m.

Additionally the sub would Test RoCSI in the water on the vehicle and use an alternative sub bottom profiler pulse for the first time SB216_2_13_16MS_SS8E. The ADCP would have new settings test 1m bin size with ADCP/Syrinx.

The whole mission should take ~20+ hours.

Review of the previously completed Autosub6000 data shows the sub will face challenging bathymetry. The autosub6000 data shows it came very close to the bottom on two occasions. It could potentially abort due to under min altitude conditions.

Fig. 7.6 Screenshot of planning module layout for A5M31

7.1.8.2.2.1 System Spec

Table 7.6 AUV system specs for A5M31

Wings	-3 degrees, middle position
Estimated Battery Use	80 %
Navigation Solution	Localiser
USBL Telemetry	Not Necessary Nice to have during the dive

7.1.8.2.2.2 OCS Parameters Spec

Table 7.7 OCS parameter specifications for A5M31

Parameter	Value
No_contact_timer	24 hours
Safety_min_alt	1.75 m
Safety_max_depth	4500m
Iridium_period	5 mins
Autosub 5 Trigger Mode	Autosub5_15m_SS_Main_SBP16ms
Norbit FLS Mode	Off

7.1.8.2.2.3 Payload Settings

Table 7.8 Payload settings for A5M31

Device	Required (Y/N)	Mode
9+ CTD	Yes inc DO	N/A

AESA Camera	Yes	N/A
Norbit Bathy	No	N/A
Edgetech 2205	YES	Sidescan HF SB216_2_13_16MS_SS8E
Wetlabs BBRT	Yes	N/A
NOC ROCSI	Yes	24 samples
Applied Physics Magnetometer	Yes	N/A

7.1.8.2.2.4 ADCP/DVL Settings

Table 7.9 ADCP/DVL settings for A5M31

Setting	Requested Values
Water Track Start range(m)	1
Water Track bin width(m)	15
Number of Bins	15
Depth Cell Width (cm)	100

7.1.8.2.3 Mission Narrative

The unexpected request for a non-standard SBP pulse threw up a software bug which required shore personnel to update some code. This was however completed on route to the mission launch site and thus did not delay launch. The AUV was successfully launched and performed the SSS survey without incident however the submarine aborted during the first track of camera survey due to an under minimum altitude event. This is when the submarine goes underneath a pre-set altitude which for this mission was set at 1.75m. The submarine went down to 0.2m which likely indicates the submarine touched the bottom.

As the submarine currently has no forward-looking OAS (due for installation 2023) the camera surveys in rough terrain were always going to be challenging. The “mini mounds” were old coral mounds with steep edges ~3-6m high. The Safety_Min_alt was decreased to 1m for future camera surveys while future camera mission heights would continue to be assessed to a case by case basis. The decision was also made to increase the Kp to 0.027 and the Kd to 0.02 on the depth controller to make the depth controller a little bit more aggressive.

From a bathymetry review of the work area it may also have been prudent to start the camera survey from the south west rather than the North East, the mini mounds are more prevalent in the north east and thus the likelihood of an abort in that area is higher.

RoCSI was trying to take 12 samples on the side scan and 12 samples on the camera. The system attempted to collect 11 samples on the sidescan portion of the mission before the camera survey under min altitude abort. It however did not manage to collect any samples due to the RoCSI motor magnetic coupling having an issue.

7.1.8.2.4 Annotated Engineering Plots

7.1.8.2.4.1 2D Navigation

Mission started in the bottom left (South West). The red line is the submarine on surface with GPS it then dives and decreases its height in stages to 15m. Each green dot is a way point on the mission. The submarine then completes 11 survey lines before attempting the 4m altitude camera survey starting in the top right.

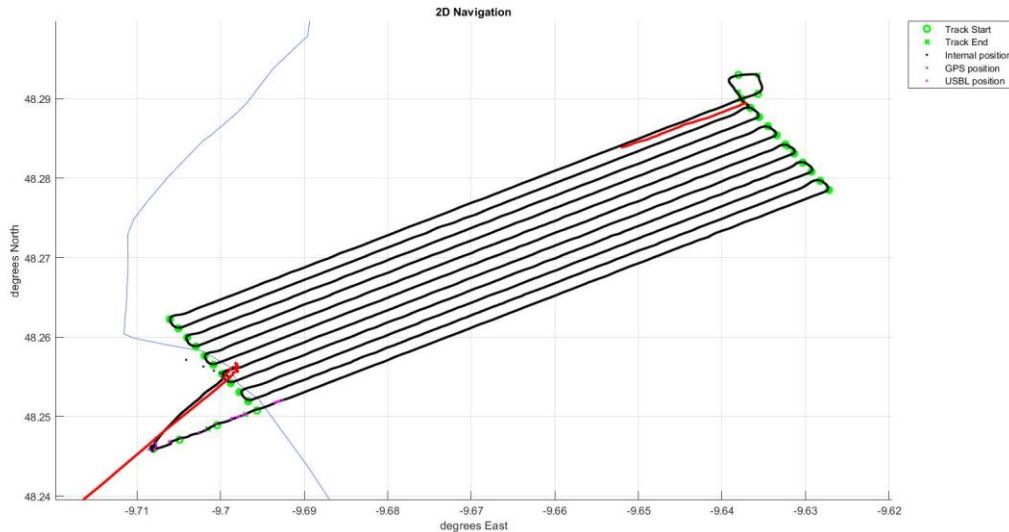

Fig. 7.7 Track plot for A5M31

7.1.8.2.4.2 Vertical Performance

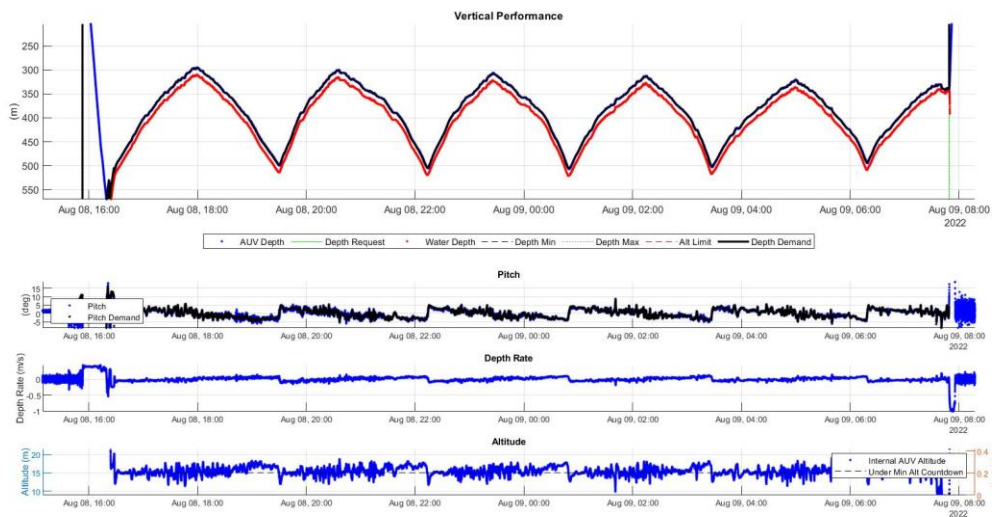

Fig. 7.8 Diagnostic plots illustrating the vertical behaviour of Autosub5 during A5M31

The vertical performance looks ok in a very rough terrain. The SSS survey at 15 m altitude has been performed without particular problems. The Camera survey at 4 meters generated an under-min altitude event on the first track after about 2 minutes spent at that altitude.

7.1.8.2.4.3 Roll Control

The roll control plot of A5M31 below indicates a consistent slight roll of $\sim 1^\circ$ which should be taken into account when analysing the data or running a patch test.

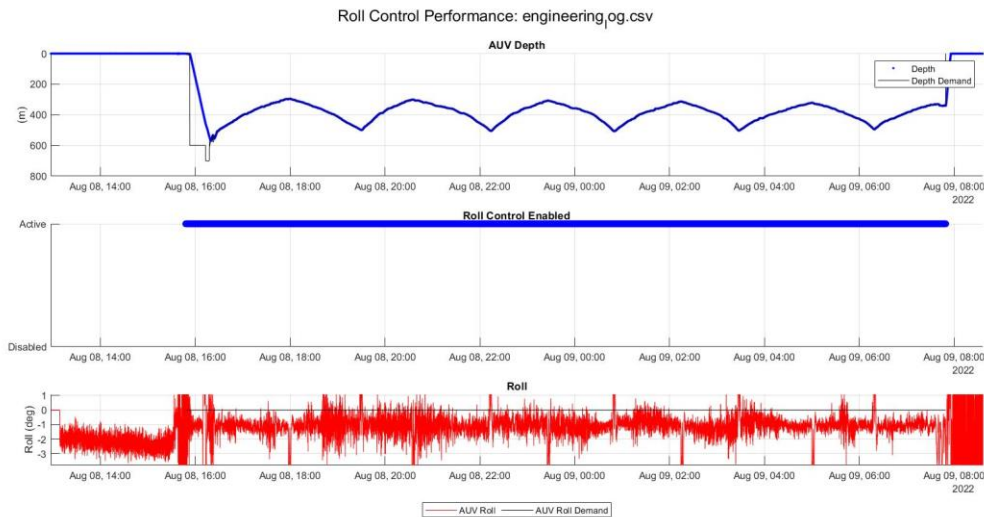

Fig. 7.9 Diagnostic plots illustrating the roll behaviour of the AUV during AS5M31

7.1.8.2.4.4 Speed Control

Due to a software bug the submarines current speed control is limited and thus as can be seen from the plot in this high current area the speed of the submarine varies between 1m/s and 1.5m/s depending on the state of the tide and the direction the submarine is travelling in.

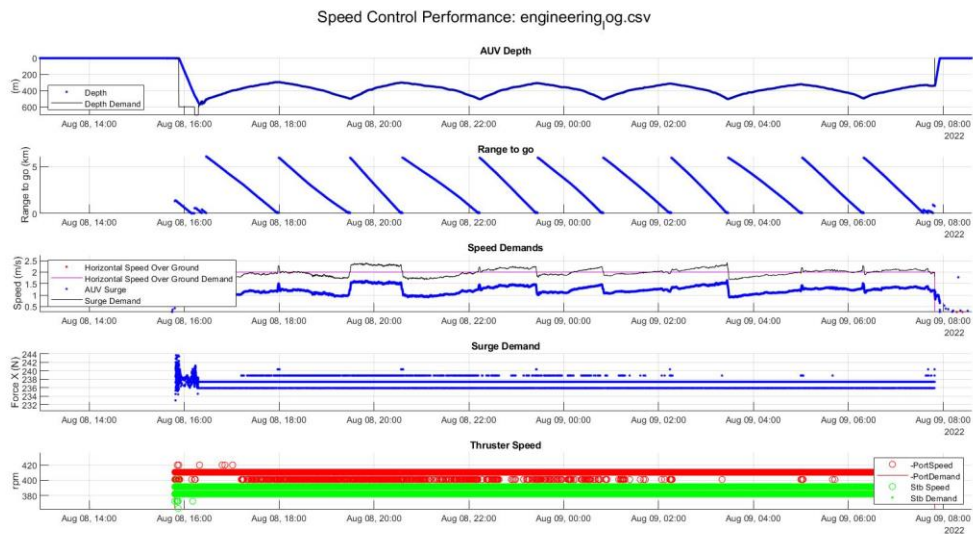

Fig. 7.10 Diagnostic plots illustrating the speed behaviour of the AUV during AS5M31

7.1.8.2.4.5 Heading control

A small amount of heading error was observed during the mission this is likely due to the local currents.

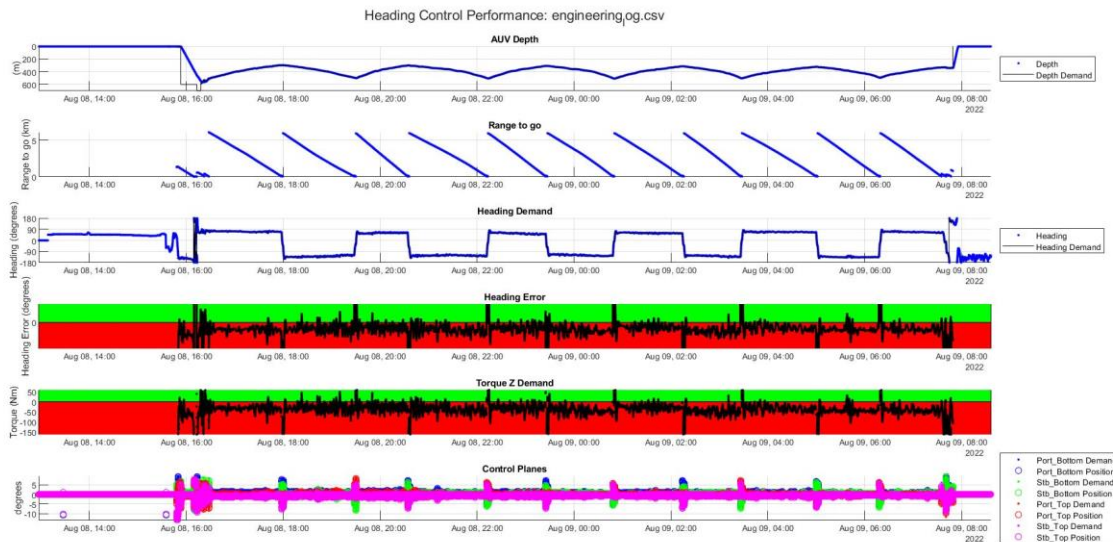

Fig. 7.11 Diagnostic plots illustrating the heading control of the AUV during A5M31

7.1.8.2.4.6 Edgetech225

Edge tech 2205 engineering data appears to show the system worked without interruption for the full mission.

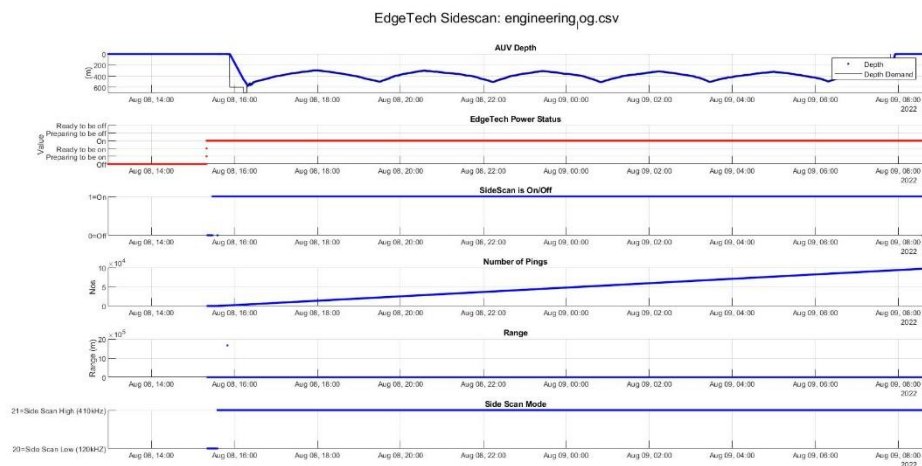

Fig. 7.12 Diagnostic plots illustrating the vehicle behaviour during the EdgeTech sidescan survey of A5M31

7.1.8.2.5 Mission Example

Initial Sidescan data of Mini Mounds as collected by Autosub 5 on A5M31.

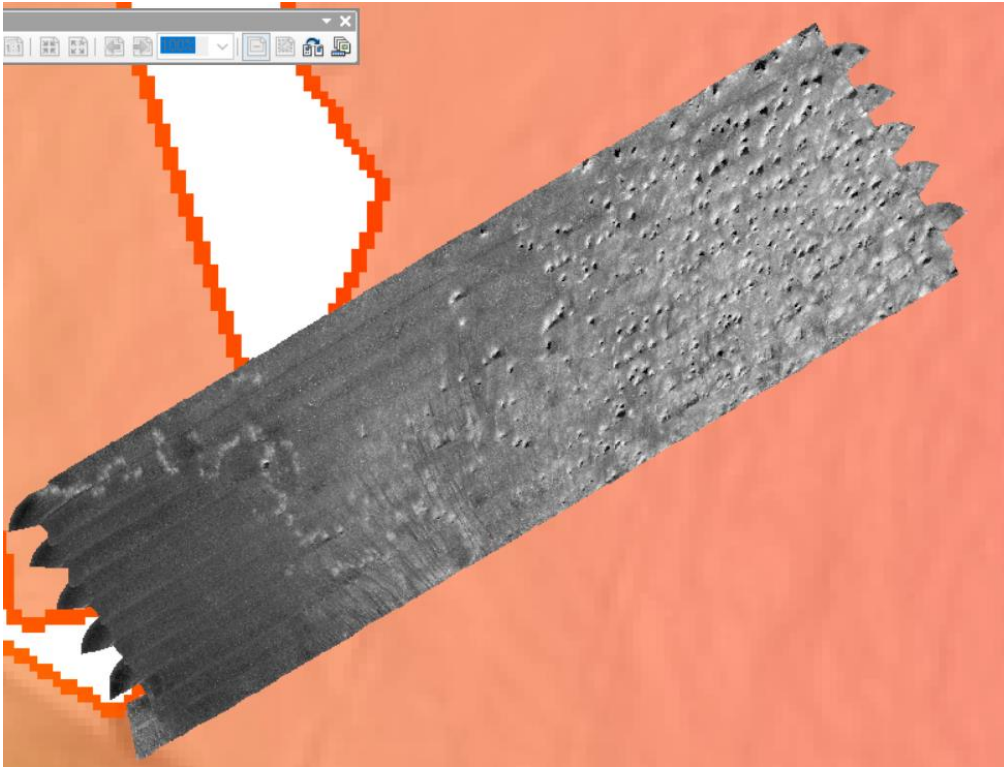

Fig. 7.13 Sidescan sonar image from A5M31

7.1.8.3. Autosub5 M32 Mission Summary

7.1.8.3.1 Mission Stats

Table 7.10 Details of mission A5M32

Mission Identifier	A5M32
Start Time	09-Aug-2022 14:50:52
Time Elapsed	4.2156 Hrs
Distance Travelled	17.5574 Km
Start Coordinates	48.2672 deg N, -9.6626 deg E
End Coordinates	48.2706 deg N, -9.6398 deg E
Max Depth	512.51 meters
Minimum Altitude Recorded	0.96m
Start Battery Voltage / Start State of Charge	55.05V / 68.5%
End Battery Voltage / End State of Charge	52.8V / 51%

7.1.8.3.2 Mission Plan Description

Autosub 5 / ... / Camera Survey only Mission89 / Version 6 (Latest)

Map

M89 launch point

Zoom Level: 12
48.287305, -9.701598
N 48 17.238, W 9 42.096

The C2 Team | ESRI

Plan Overview SEND PLAN

- 13 out of 41 total actions used in this plan
- Maximum planned depth 2000 m
- Minimum planned altitude 4 m
- Estimated total distance 18.98 km ?
- Plan will timeout after 24:00:00 estimated plan time between 03:25:31 and 08:33:48 ?
- Dive 1 will timeout after 22:13:20 estimated dive time between 02:25:31 and 06:03:48 ?

The Submarine was recovered from mission A5M31 at ~9am on the 9th August. It was recovered, recharged and back in the water to start its next mission 6 hours later. This mission A5M32 would be to complete the same planned camera survey which the submarine had just aborted from. A camera only mission was planned with the mission being run starting from the south west as the A5M31 survey indicates the “mini mounds” get progressively worse toward the north east.

Fig. 7.14 Screenshot of planning module layout for A5M32

7.1.8.3.2.1 System Spec

Table 7.11 AUV system specs for A5M32

Wings	-3 degrees, middle position
Estimated Battery Use	6 KWh
Navigation Solution	Localiser
USBL Telemetry	Required – during dive

7.1.8.3.2.2 OCS parameters Spec

Table 7.12 OCS parameter specifications for A5M32

Parameter	Value
No_contact_timer	6 hours
Safety_min_alt	1m
Safety_max_depth	4500m
Iridium_period	5 mins
Autosub 5 Trigger Mode	3m Camera, sbp 5ms
Norbit FLS Mode	Fls10mAlt_400kHz_Dy152

7.1.8.3.2.3 Payload Settings

Table 7.13 Payload settings for A5M32

Device	Required (Y/N)	Mode
9+ CTD	Yes inc DO	N/A
AESA Camera	Yes	1Hz
Norbit Bathy	No	N/A
Edgetech 2205	No	N/A
Wetlabs BBRT	Yes	N/A
NOC ROCSI	No	N/A
Applied Physics Magnetometer	Yes	N/A

7.1.8.3.2.4 ADCP/DVL Settings

Table 7.14 ADCP/DVL settings for A5M32

Setting	Requested Values
Water Track Start range(m)	1
Water Track bin width(m)	15
Number of Bins	15
Depth Cell Width (cm)	100

7.1.8.3.3 Mission Narrative

The submarine was launched and drove itself to the south west while diving to the correct depth. Once at the south west the submarine turned north and began its Zig-Zag survey at 4m altitude. The submarine did not abort this time however the mission was cut short due to ship time constraints because the ROV staff required to deploy the ROV approaching the end of their shift. During its deployment the submarine collected ~9000 useful photos.

A surface command was sent via acoustics to the submarine. The submarine came up in the safety surface state, which is designed to have the sub “loiter” at ~0.5m/s on the surface holding a waypoint. However due

to a combination of the waves and the sub being underway when the sub began to power forward, it slipped under the surface and moved away from the ship. The ship proceeded to follow the submarine with the Ops team sending it abort commands until one got through. After a few minutes the sub aborted and became stable on the surface. The ship then moved in for recovery. The safety surface command was then replaced for the rest of the expedition with either a safety stop or an abort.

7.1.8.3.4 Annotated Engineering Plots

7.1.8.3.4.1 2D Navigation

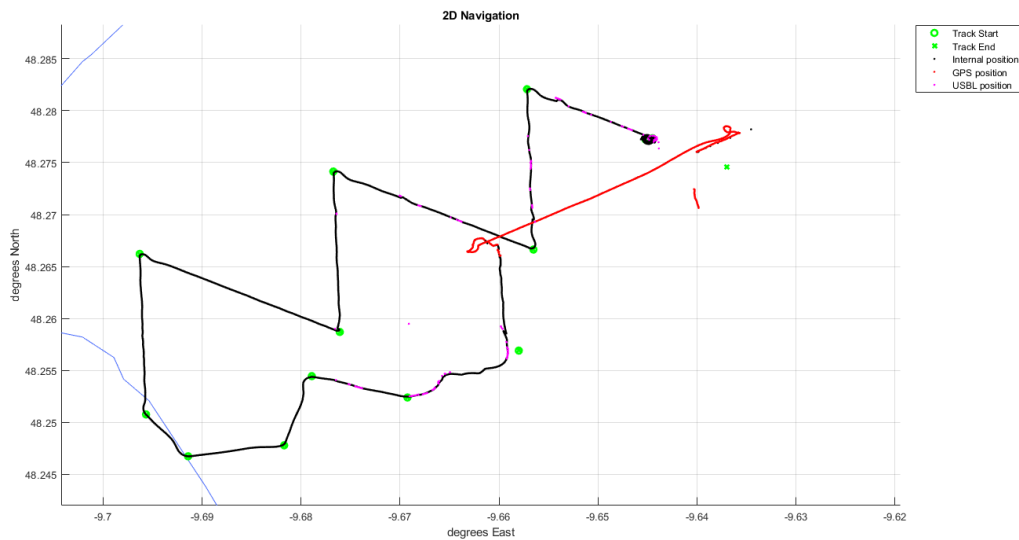

Fig. 7.15 Track plot for AS5M32

7.1.8.3.4.2 Vertical Performance

To insure the best possible success to the mission the submarine was taken down to the 4m camera survey altitude in stages. This is to prevent a large overshoot of the submarine in its control loops and thus the submarine getting too close to the seabed.

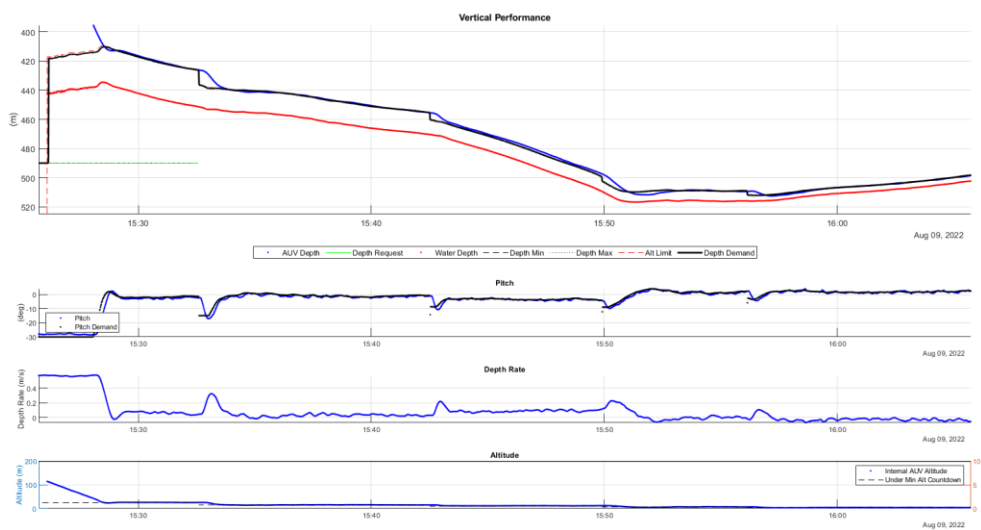

Fig. 7.16 Diagnostic plots illustrating the vertical behaviour of Autosub5 during AS5M32

7.1.8.3.5 Mission Examples

7.1.8.3.5.1 Initial Camera Photos



Fig. 7.17 Example photographs from AS5M32

7.1.8.3.5.2 Forward looking Sonar

During this mission the operations team were also able to turn on the forwards looking sonar and gather useful engineering development data. This data will be used to create the camera obstacle avoidance system allow the submarine to reliably complete surveys at 3m altitudes. Due for its first trials on DY166 2023.

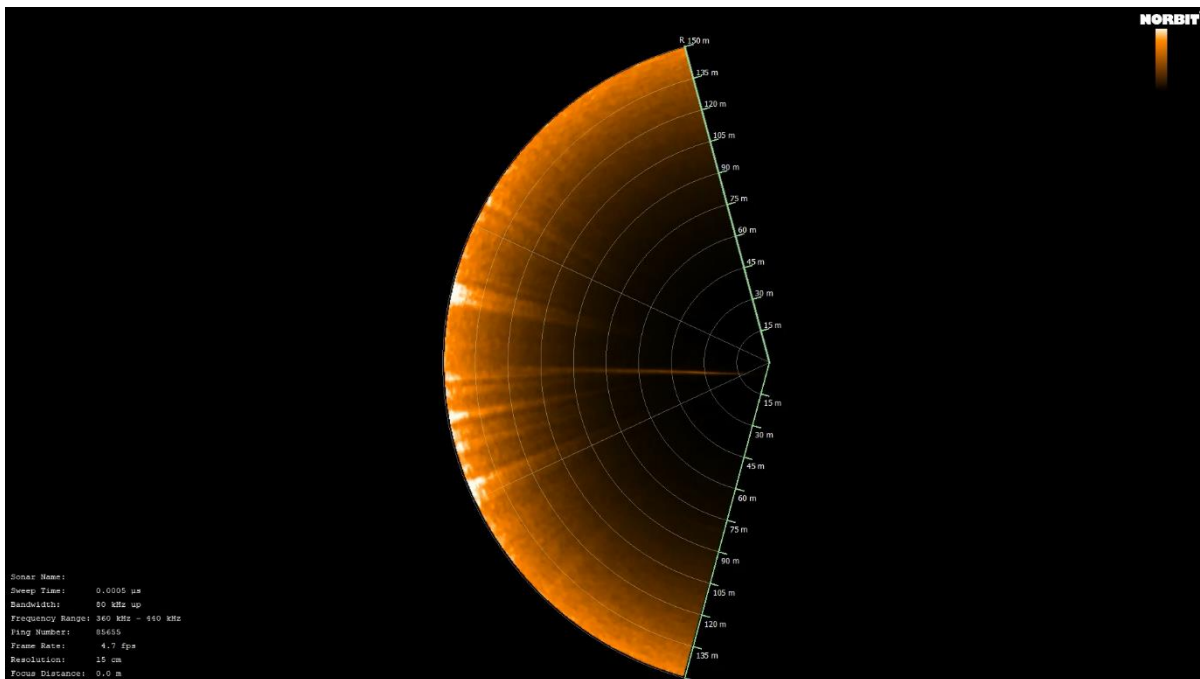

Fig. 7.18 Example screenshot of the forward looking sonar display

7.1.8.4. Autosub5 M33 Mission Summary

7.1.8.4.1 Mission Statistics

Table 7.15 Details of mission A5M33

Total Mission Duration	24.5153 Hrs
Distance Travelled (km)	80.186 km
Maximum Depth (m)	205.03 m
Minimum Altitude (m)	0.2 m
Battery Voltage end of mission	48.466 (5.0 % SOC)

7.1.8.4.2 Mission Plan Description

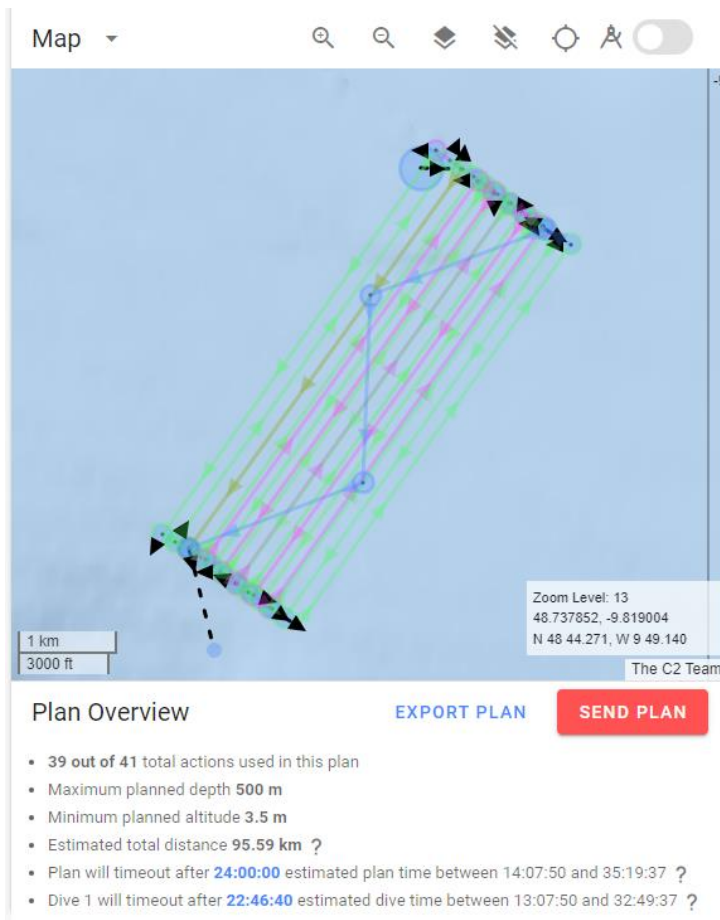

Fig. 7.19 Screenshot of planning module layout for A5M33

Complete the eastern section of the “Sandwaves” survey previously completed by Autosub 6000 M88 in 2015 on JC125. This mission consists of an initial 6 x 5km multibeam survey at 50m altitude followed by a 12 x 5km long high frequency side scan survey at an altitude of 15m followed by camera images at 3.5m.

7.1.8.4.3 Mission Narrative

The mission performed correctly the multibeam survey even if a wrong timeout in one of the tracks made one of the legs of the lawnmower shorter with respect to the others.

Port thruster failed to recover after being power cycled due to an overcurrent monitoring function triggering. This happened during the SSS survey. The thruster never recovered after the power cycle, the serial line was mute. The rest of the mission has been performed with one thruster only. The sub aborted due to an under in altitude event 2 minute after the beginning of the camera survey.

7.1.8.4.4 Annotated Engineering Plots

7.1.8.4.4.1 2D/3D Navigation

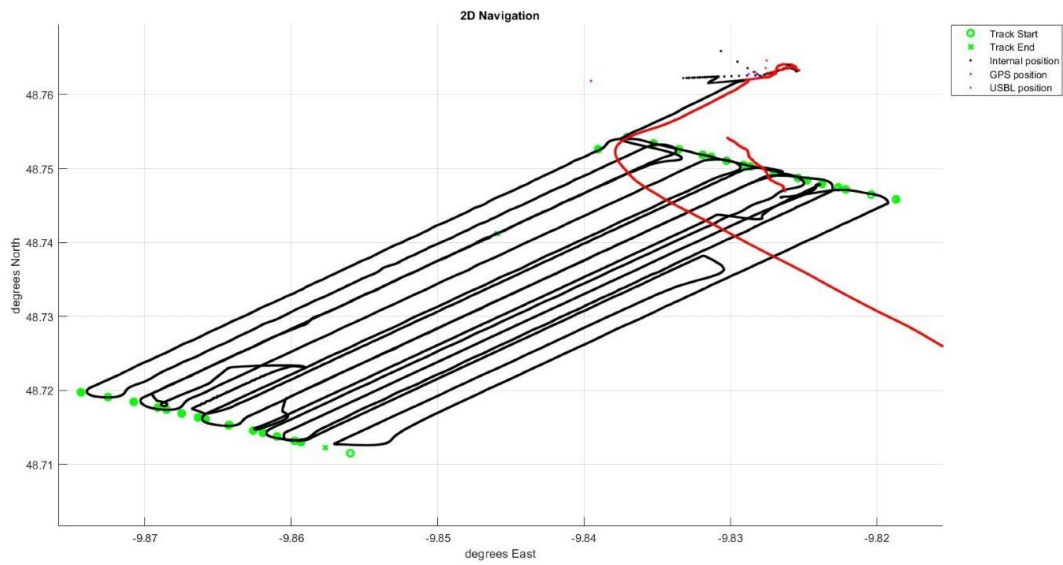

Fig. 7.20 3D navigation plot for A5M33

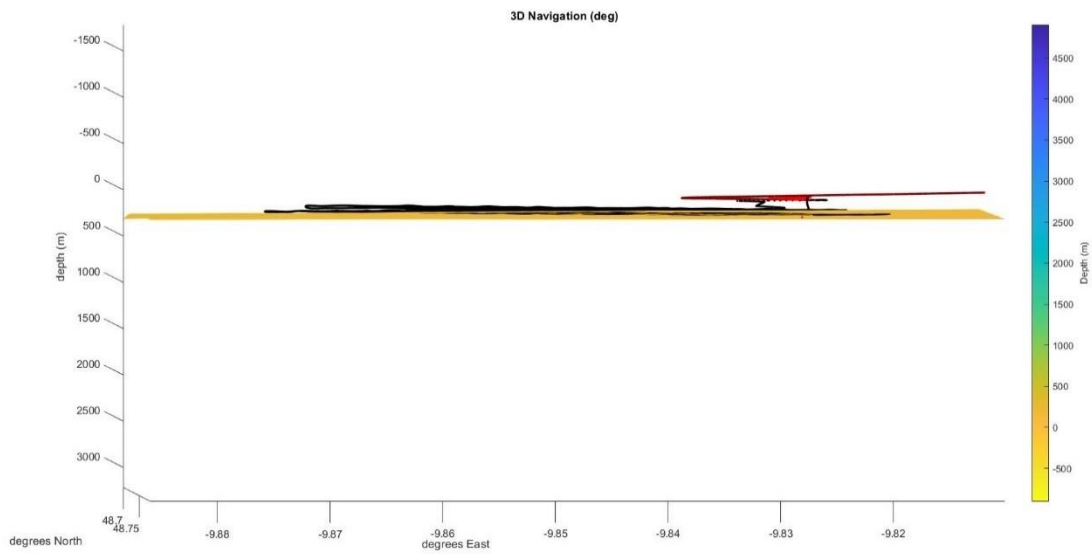

Fig. 7.21 AUV depth for A5M33

7.1.8.4.4.2 Vertical Performance

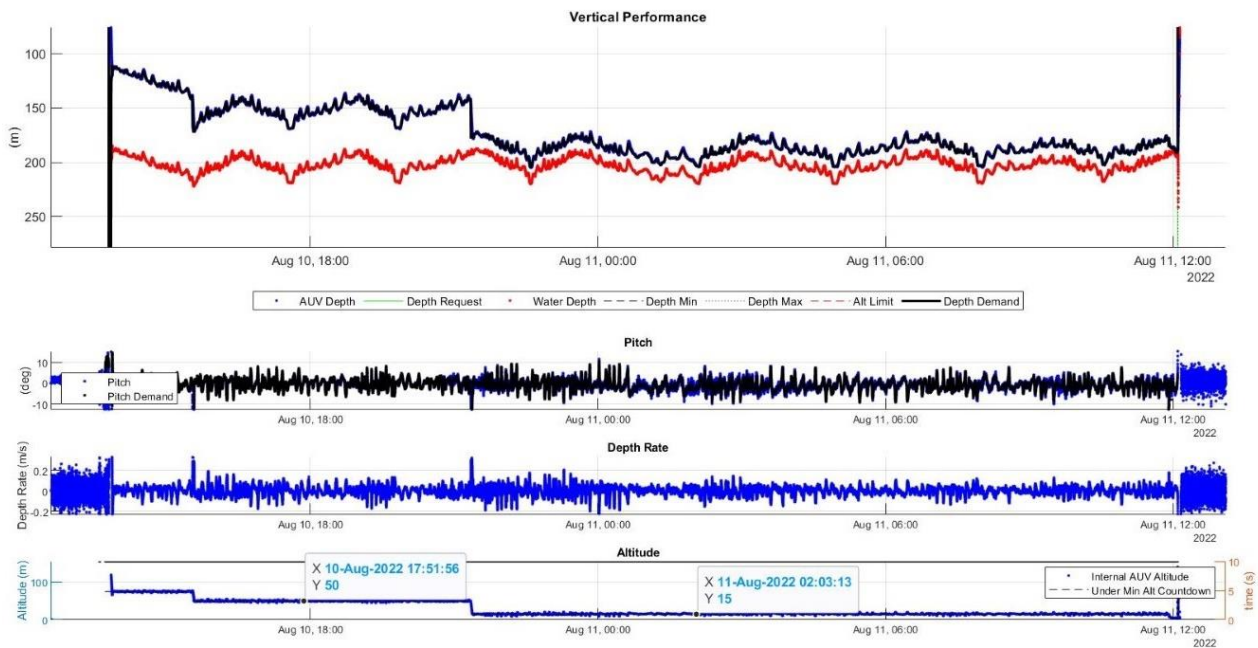

Fig. 7.22 Vertical behaviour of Autosub5 during A5M33

7.1.8.4.4.3 Heading Control

In this plot it is possible to see the actions of the control planes after losing the port thrusters to compensate the heading (Fig. 7.23).

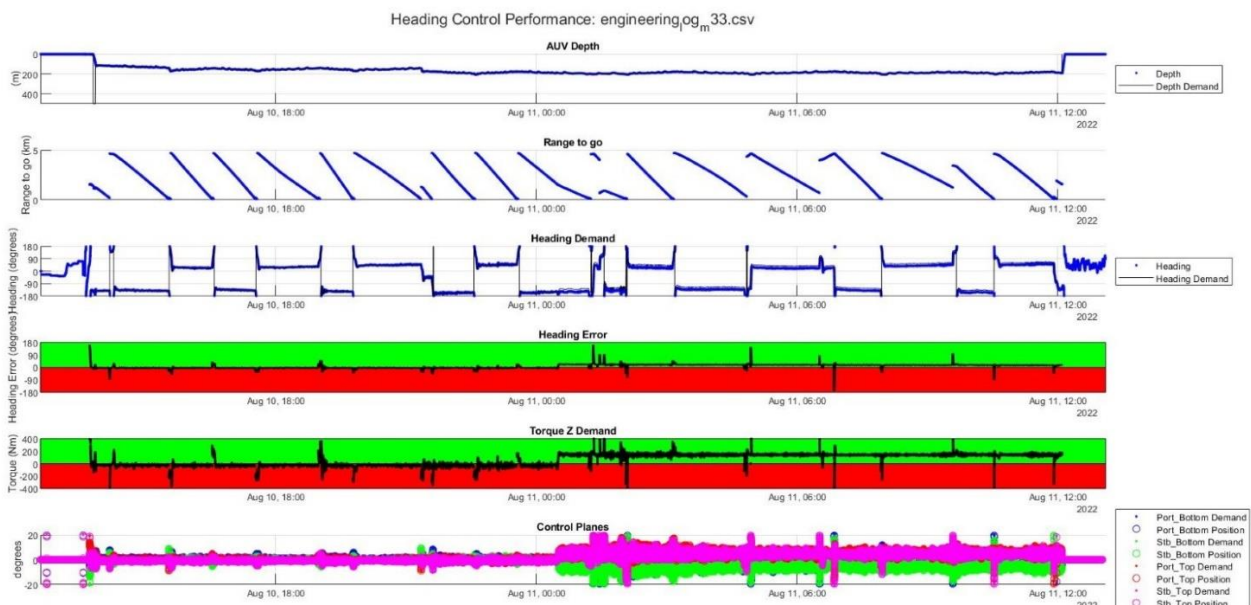

Fig. 7.23 Heading control performance during A5M33

7.1.8.4.4.4 Speed Control

In this lot is visible the moment when the port thruster stops working. The surge demand increases to compensate.

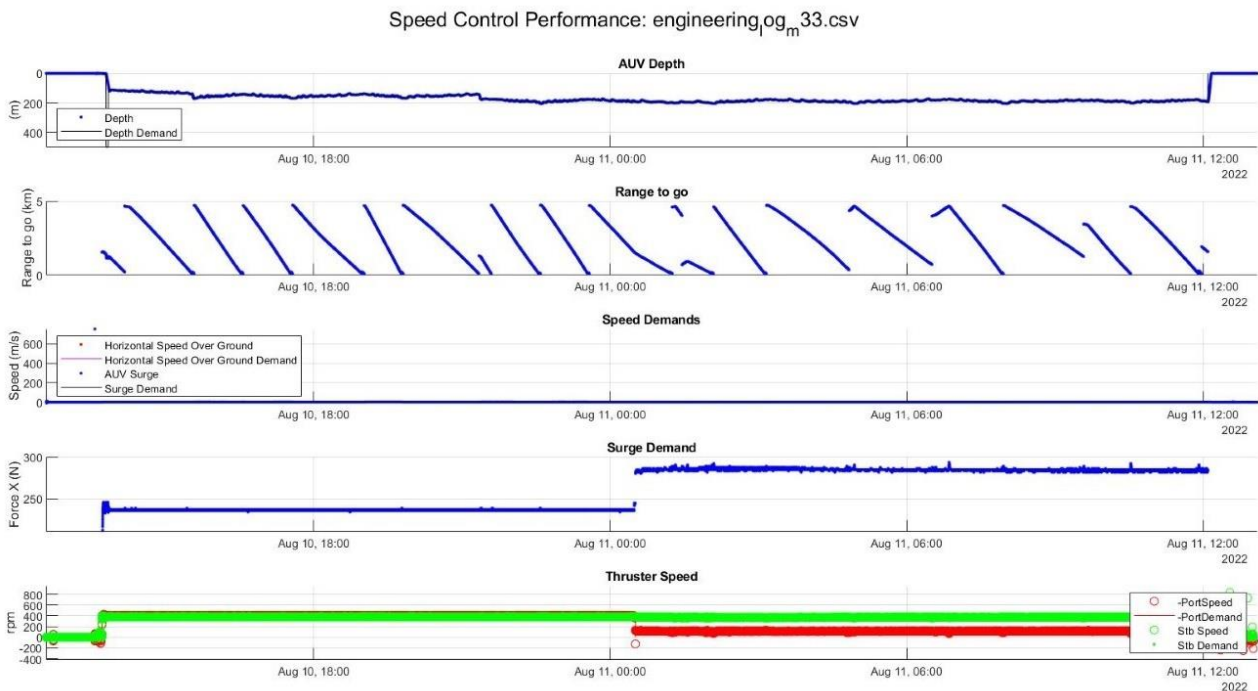

Fig. 7.24 Speed control performance during A5M33

7.1.8.4.4.5 Countdown Timers

In this graph it is possible to observe the under min altitude timer going down to zero and triggering the abort (Fig. 7.25).

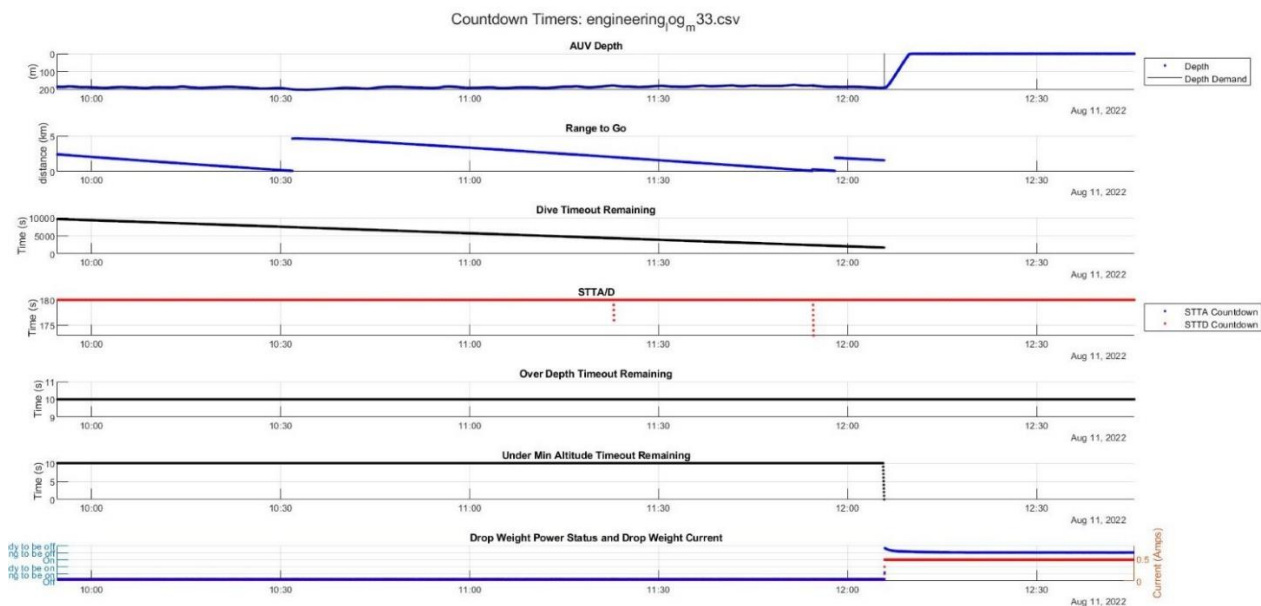

Fig. 7.25 Countdown timers during A5M33

7.1.8.4.4.6 Power Consumption

This plot demonstrates the drop in the power consumption due to the port thruster fault (Fig. 7.26).

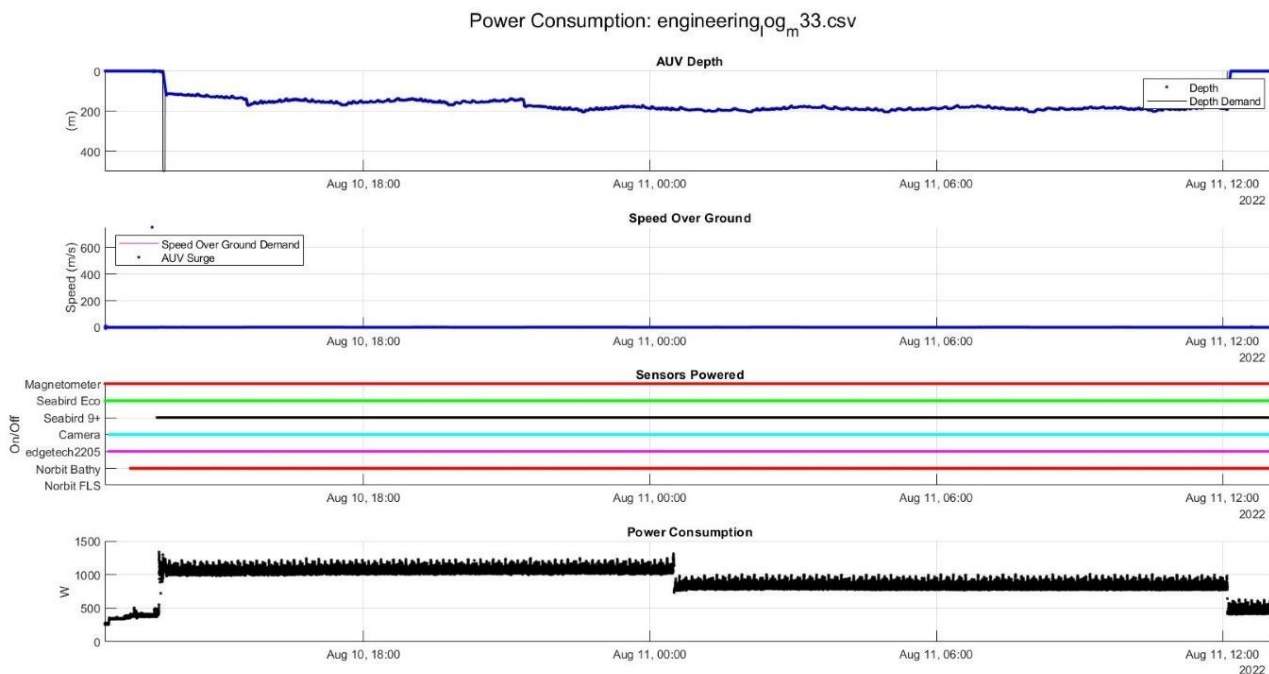

Fig. 7.26 Power consumption of the AUV during A5M33

7.1.8.4.4.7 Roll Performance

The roll steady state error goes from ~ -1 deg to ~ -5 deg because of the port thruster failure (Fig. 7.27).

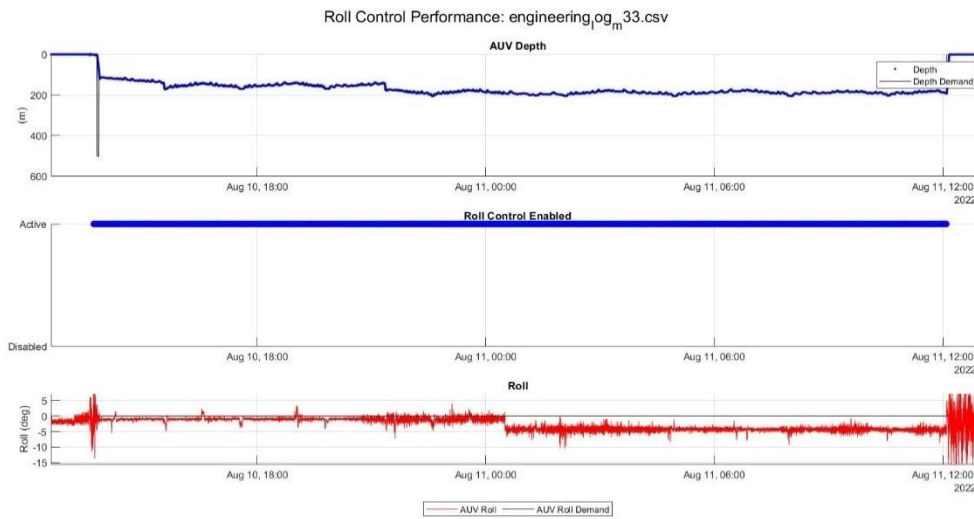

Fig. 7.27 Roll controls of the AUV during A5M33

7.1.8.4.5 Mission Faults

The main fault associated with this mission is the port thruster failure. It is not clear what caused the overcurrent issue. A relevant scratch has been found on the port propeller. However, we don't have enough evidence to say that this occurred during this mission or before. The most accredited hypothesis is that something (fishing line?) was preventing the propeller from spinning normally causing the extra load and so the overcurrent event on the thruster. It is not clear however why it has not been found tangled in the prop.

The thruster didn't recover from the power cycle leaving the serial line mute for the rest of the mission. The suspicion is around a firmware bug.



Fig. 7.28 Photograph of the propeller plane after A5M33

7.1.8.4.6 Initial Assessment of Sensor Data

7.1.8.4.6.1 Seabird 9+

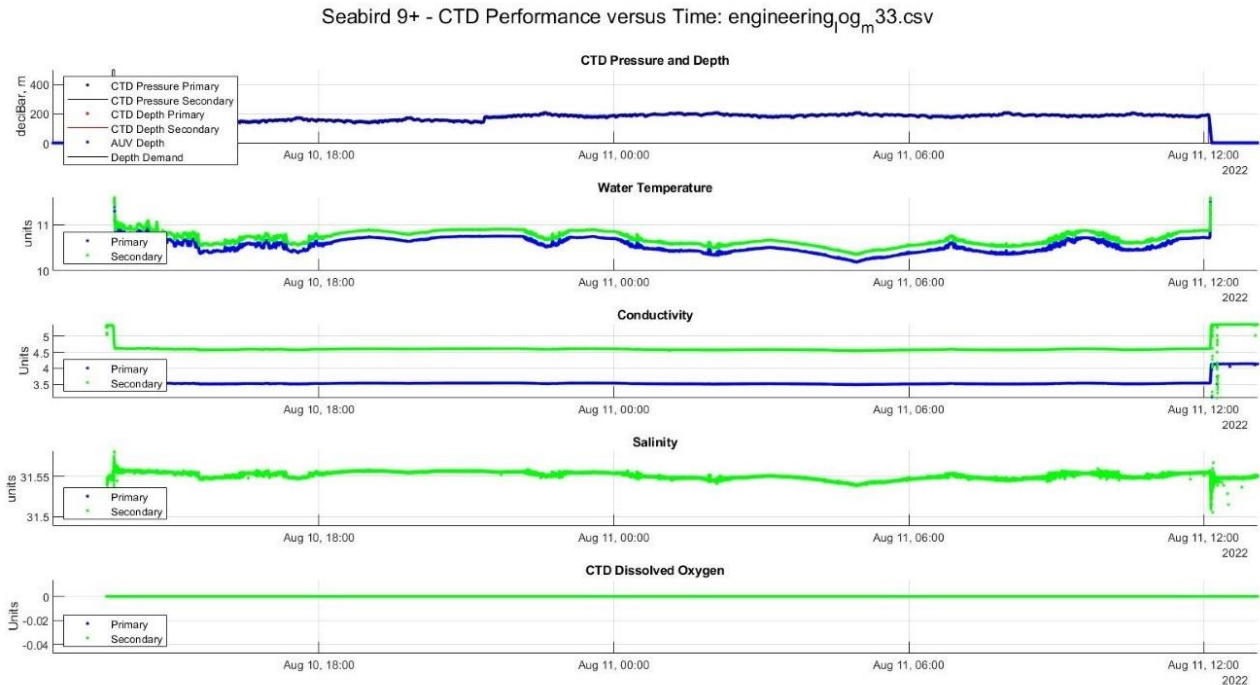

Fig. 7.29 CTD measurements during A5M33

7.1.8.4.6.2 Norbit Bathy

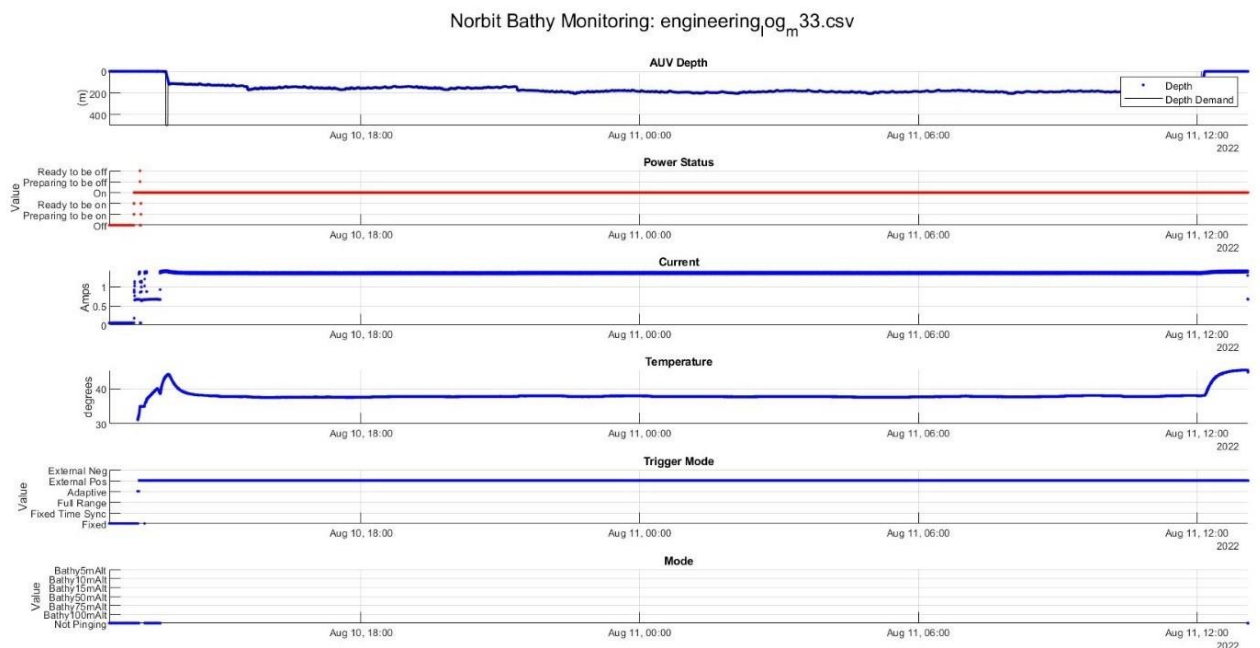

Fig. 7.30 Norbit multibeam performance data

7.1.8.4.6.3 Edgetech225

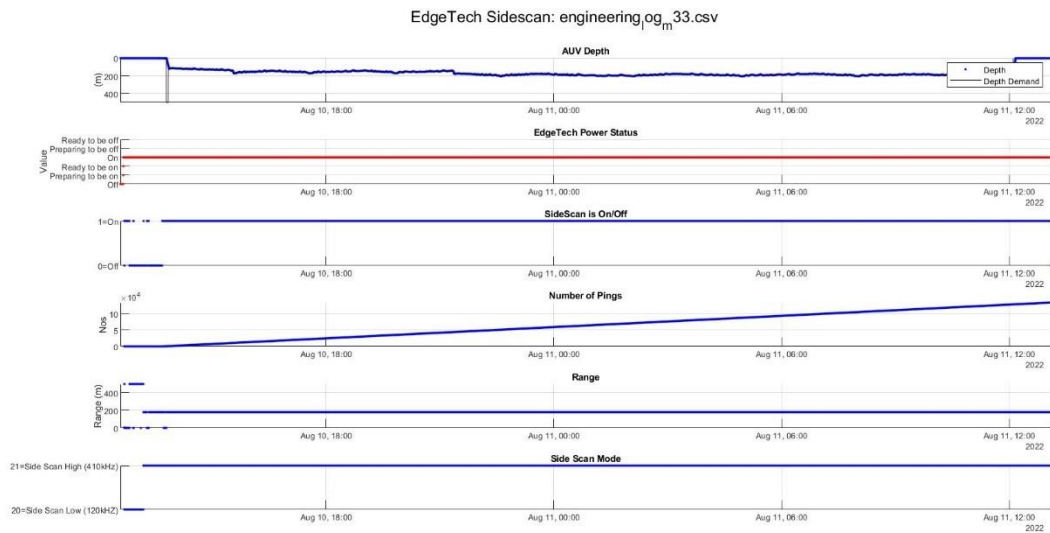

Fig. 7.31 EdgeTech sidescan sonar performance data

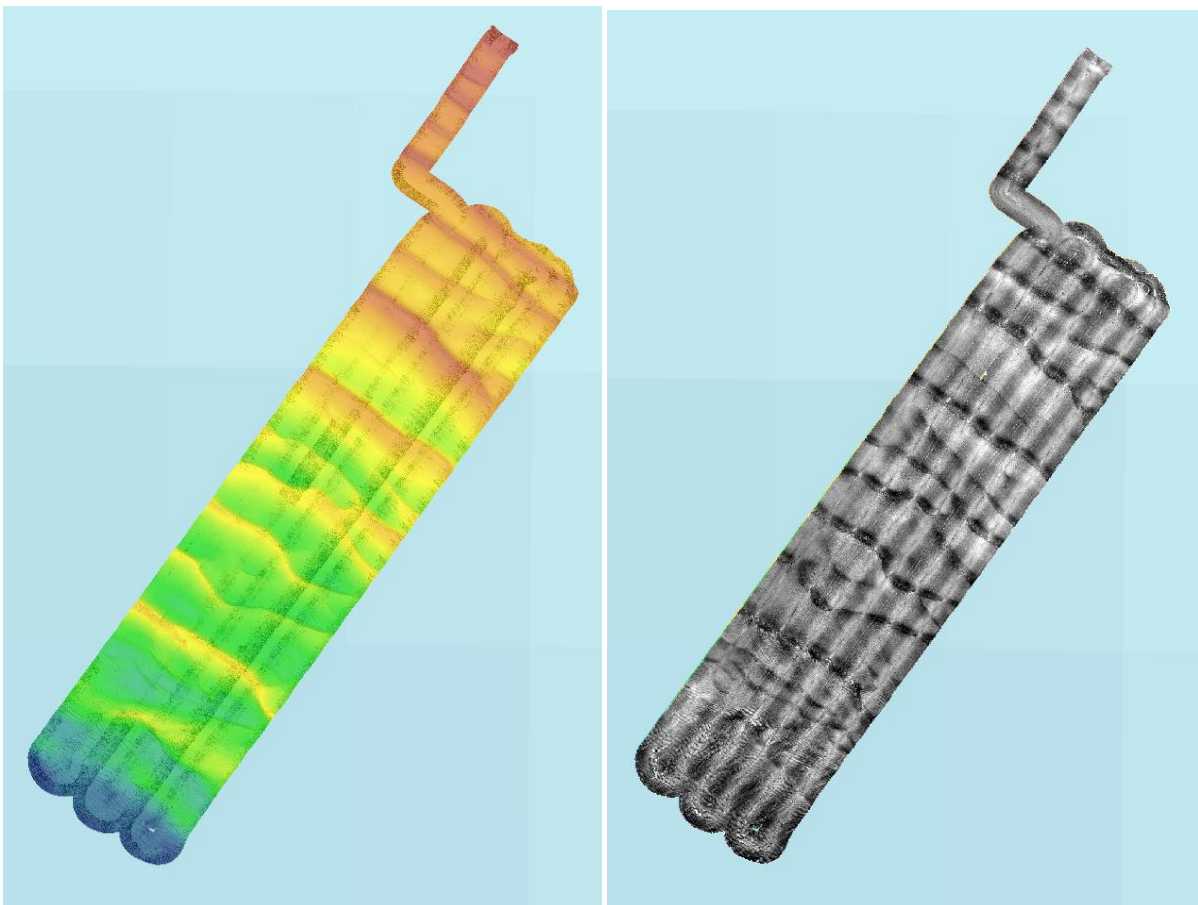

Fig. 7.32 Bathymetry and backscatter collected during A5M33

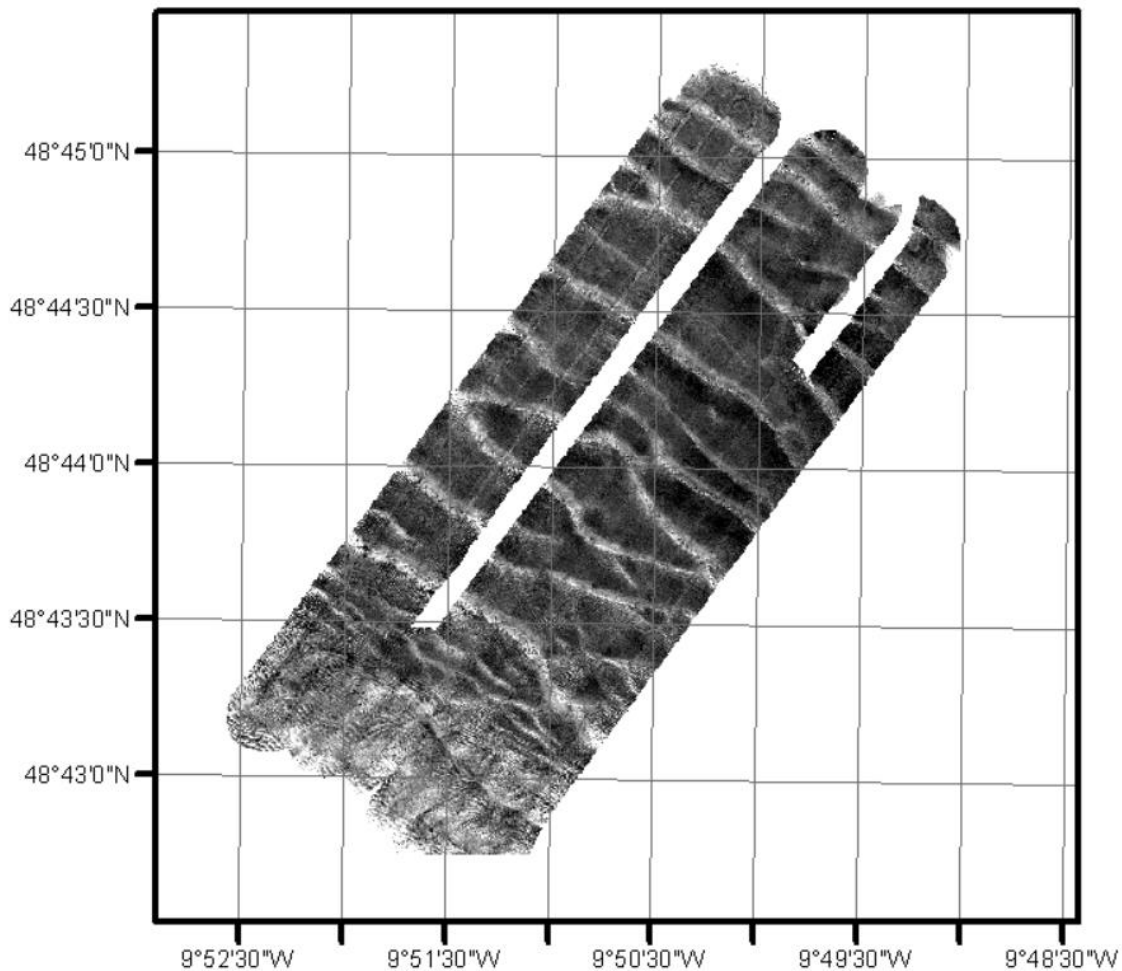

Fig. 7.33 Sidescan sonar data collected during A5M33

7.1.8.5. Autosub5 M34 Mission Summary

7.1.8.5.1 Mission Statistics

Table 7.16 Details of mission A5M34

Mission Identifier	A5M34
Start Time	12-Aug-2022 15:39:53
Time Elapsed	20.1083 Hrs
Distance Travelled	105.0437 Km
Start Coordinates	48.4943 deg N, -9.6284 deg E
End Coordinates	48.5052 deg N, -9.6528 deg E
Max Depth	1062.4714 meters
Minimum Altitude Recorded	31.4m
Start Battery Voltage / Start State of Charge	57.96V / 97%
End Battery Voltage / End State of Charge	50.342V / 23.5%

7.1.8.5.2 Mission Plan Description

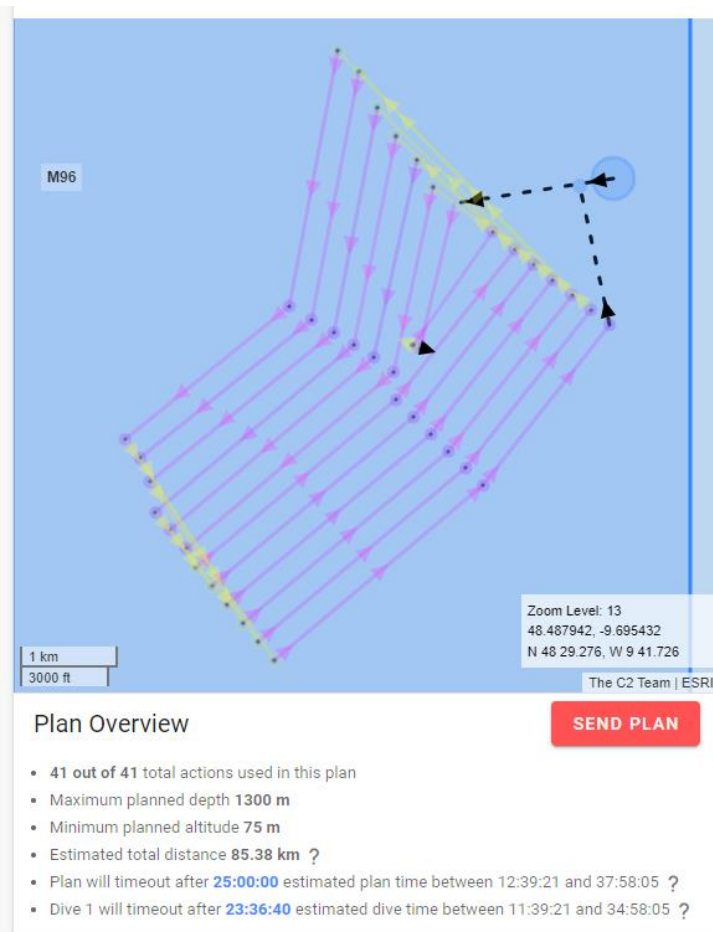

Fig. 7.34 Screenshot of planning module layout for A5M34

7.1.8.5.2.1 System Spec

Table 7.17 AUV system specs for A5M34

Wings	-3 degrees, middle position
Estimated Battery Use	22 KWh

7.1.8.5.2.2 Navigation

Table 7.18 AUV Navigation settings for A5M34

Navigation Solution	Localiser
USBL Telemetry	Required

7.1.8.5.2.3 OCS Critical Parameters Spec

Table 7.19 OCS parameter specifications for A5M34

Parameter	Value
No_contact_timer	24 hours
Safety_min_alt	15m
Safety_max_depth	4500m
Iridium_period	5 mins

7.1.8.5.2.4 Trigger Configuration

Table 7.20 Trigger Configuration for A5M34

Autosub 5 Trigger Mode	Autosub5_75m_Multibeam_Main_SBP40ms
Norbit FLS Mode	N/A

7.1.8.5.2.5 Payload Settings

Table 7.21 Payload settings for A5M34

Device	Required (Y/N)	Mode
9+ CTD	Yes inc DO	N/A
AESA Camera	no	N/A
Norbit Bathy	Yes	400khz 75_DIR20 140
Edgetech 2205	Yes	Low Frequency 40ms 2-8khz
Wetlabs BBRT	Yes	N/A
NOC ROCSI	no	no
Applied Physics Magnetometer	Yes	N/A

7.1.8.5.2.6 ADCP/DVL Settings

Table 7.22 ADCP/DVL settings for A5M34

Setting	ALR Default Value	Requested Values
Water Track Start range(m)	8.5	1
Water Track bin width(m)	96	75
Number of Bins	12	75
Depth Cell Width (cm)	800	100

7.1.8.5.2.7 ROCSI Setting

Table 7.23 ROCSI Settings for A5M34

Min Depth	Max Depth	Clean	Number of samples	Litres	Time out
400	1500	1	24	2	3600

7.1.8.5.3 Mission Narrative

Explorer Canyon 400kHz multibeam and 120kHz Sidescan. All Data successfully collected.

All data collected successfully. Port thruster continues to draw 2A more than the Starboard thruster and operates 8°C higher than its counterpart, but had no issues completing the mission.

7.1.8.5.4 Annotated Engineering Plots

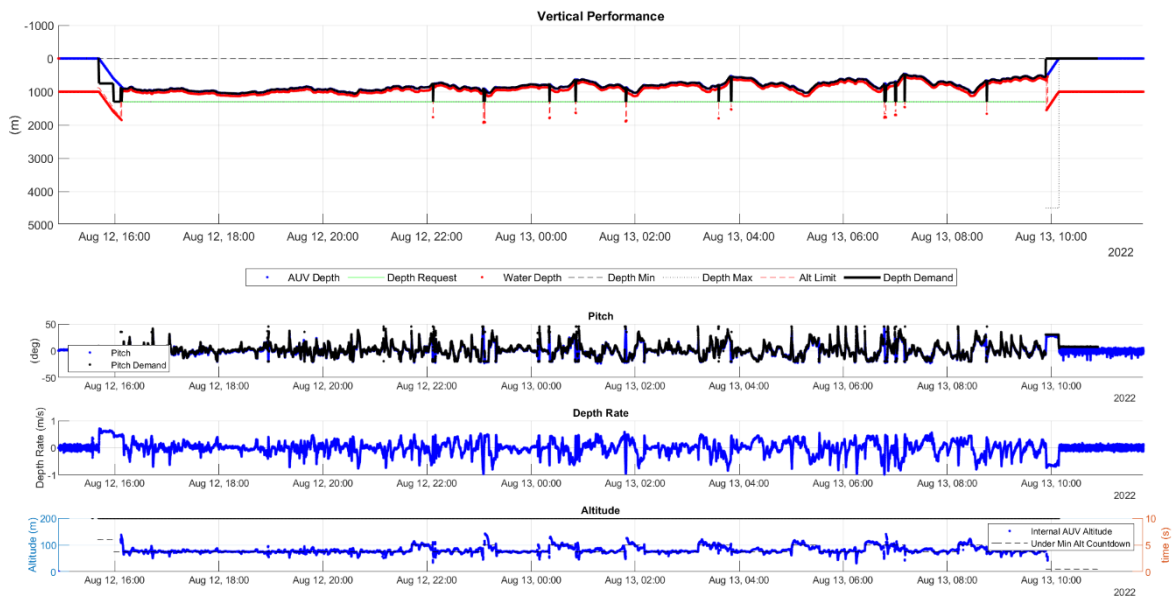

Fig. 7.35 Vehicle vertical performance during A5M34

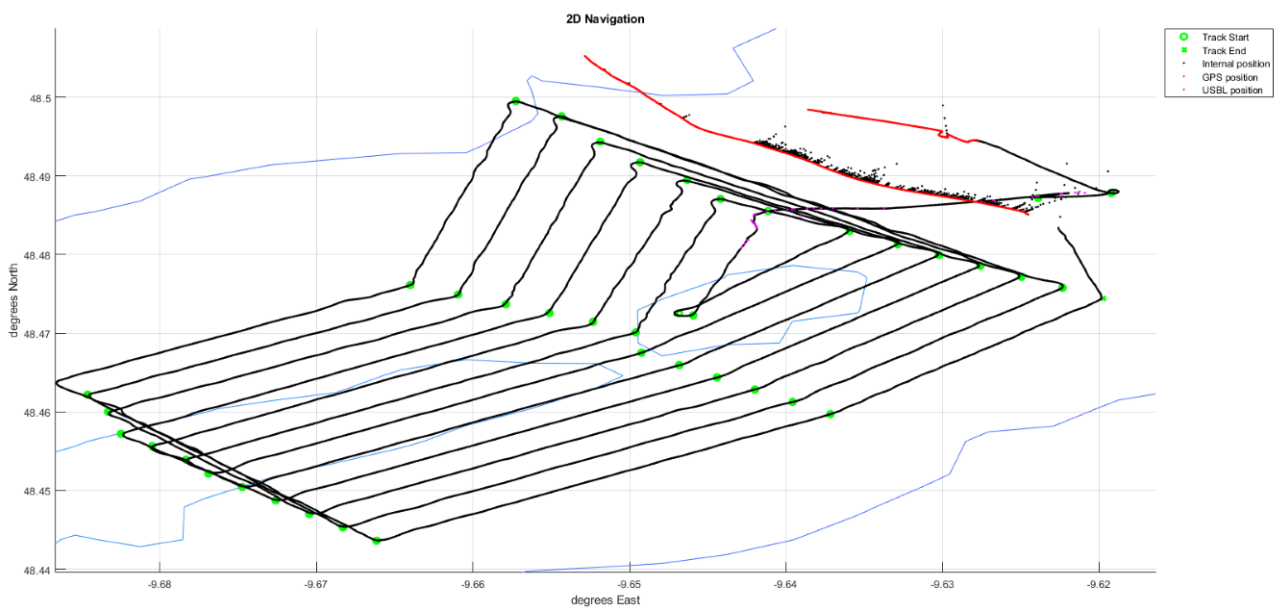

Fig. 7.36 A5M34 Mission lines

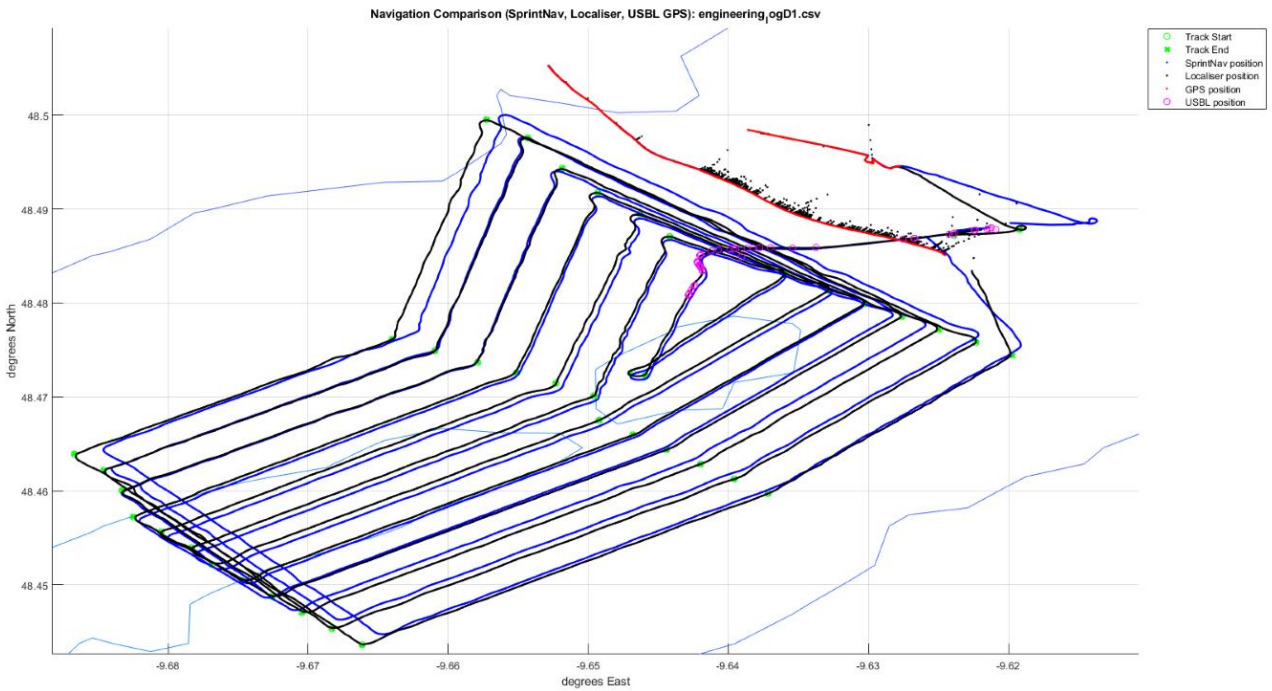

Fig. 7.37 A5M34 Navigation comparison

Position updates were provided during descent by USBL.

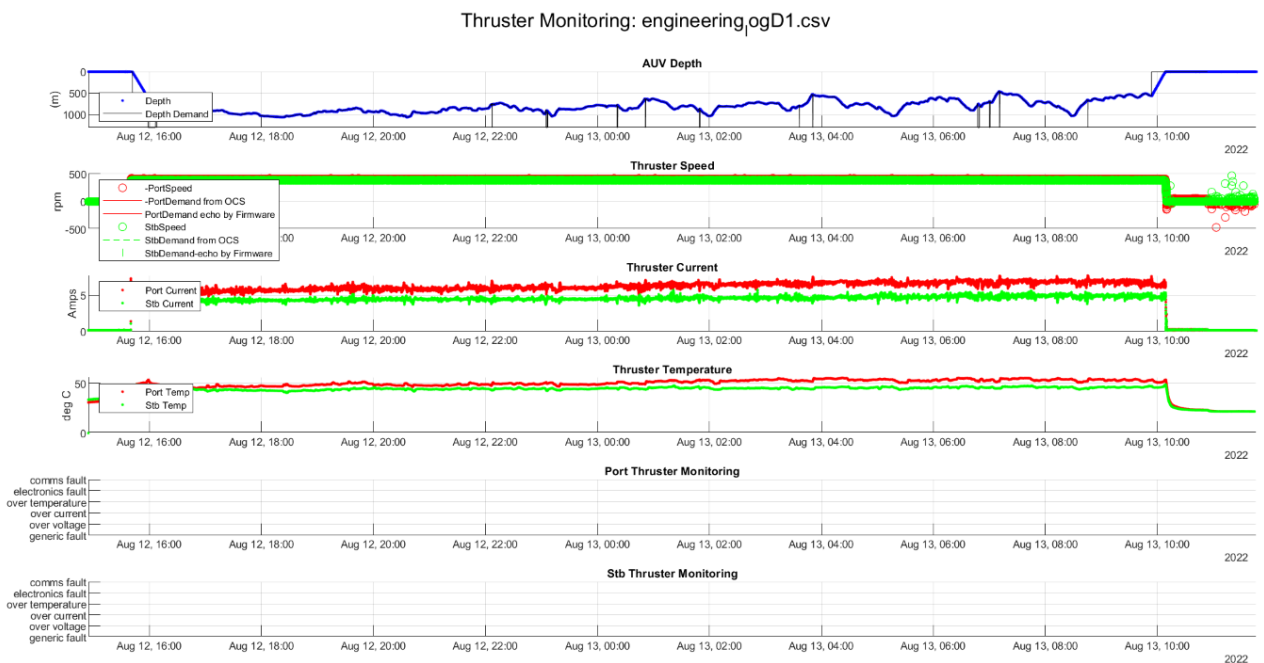

Fig. 7.38 A5M34 Thruster diagnostics

7.1.8.5.5 Mission Examples

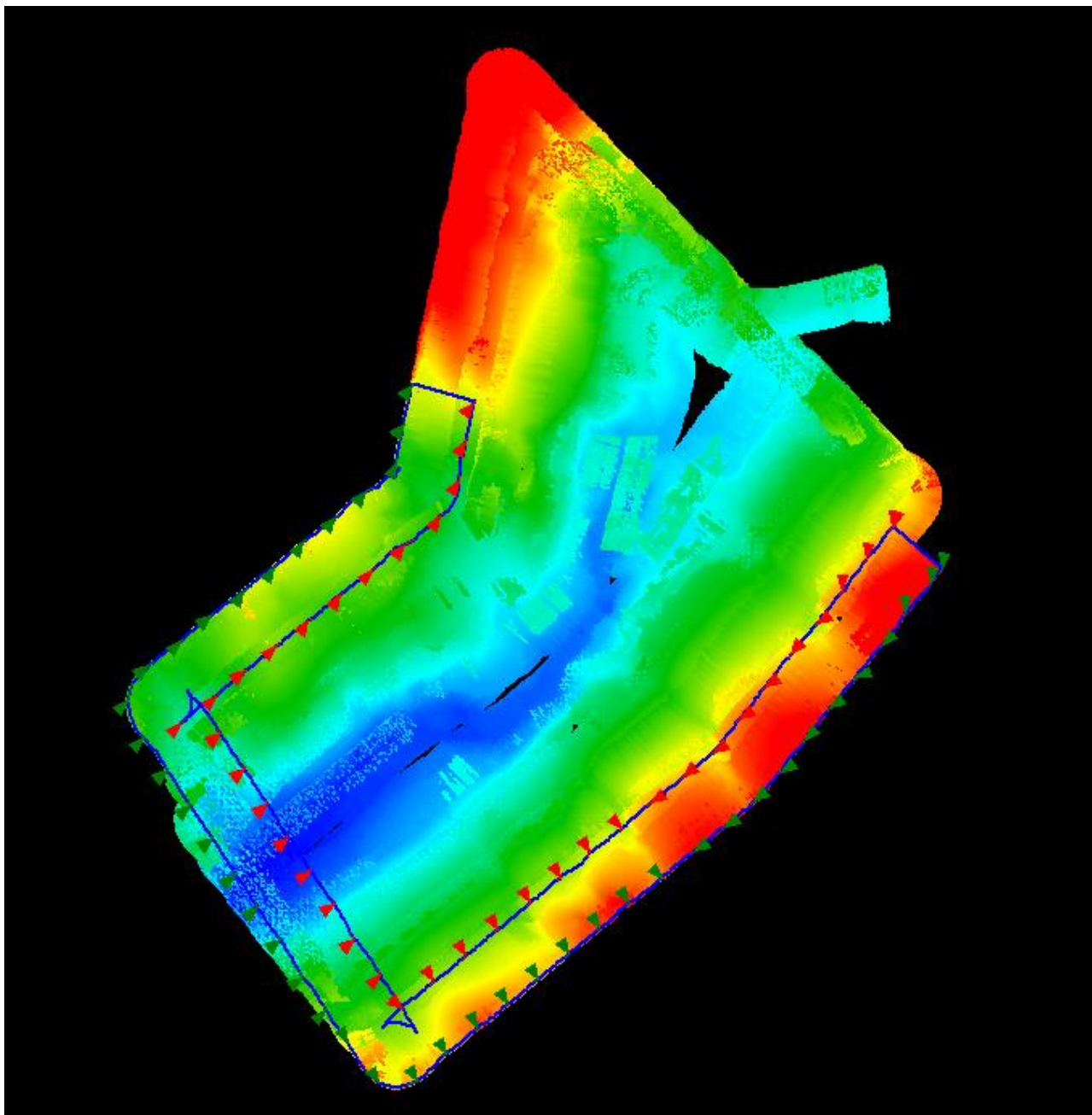

Fig. 7.39 A5M34 unprocessed multibeam data – Explorer Canyon

7.1.8.6. Autosub5 M35 Mission Summary

7.1.8.6.1 Mission Statistics

Table 7.24 Details of mission A5M34

Mission Identifier	A5M35
Start Time	14-Aug-2022 11:23:13
Time Elapsed	7.3783 Hrs
Distance Travelled	30.5355 Km
Start Coordinates	48.7539 deg N, -10.434 deg E
End Coordinates	48.7676 deg N, -10.4593 deg E
Max Depth	924.1964 meters
Minimum Altitude Recorded	12.85m
Start Battery Voltage / Start State of Charge	57.934V / 96.5%
End Battery Voltage / End State of Charge	55.526V / 71%

7.1.8.6.2 Mission Plan Description

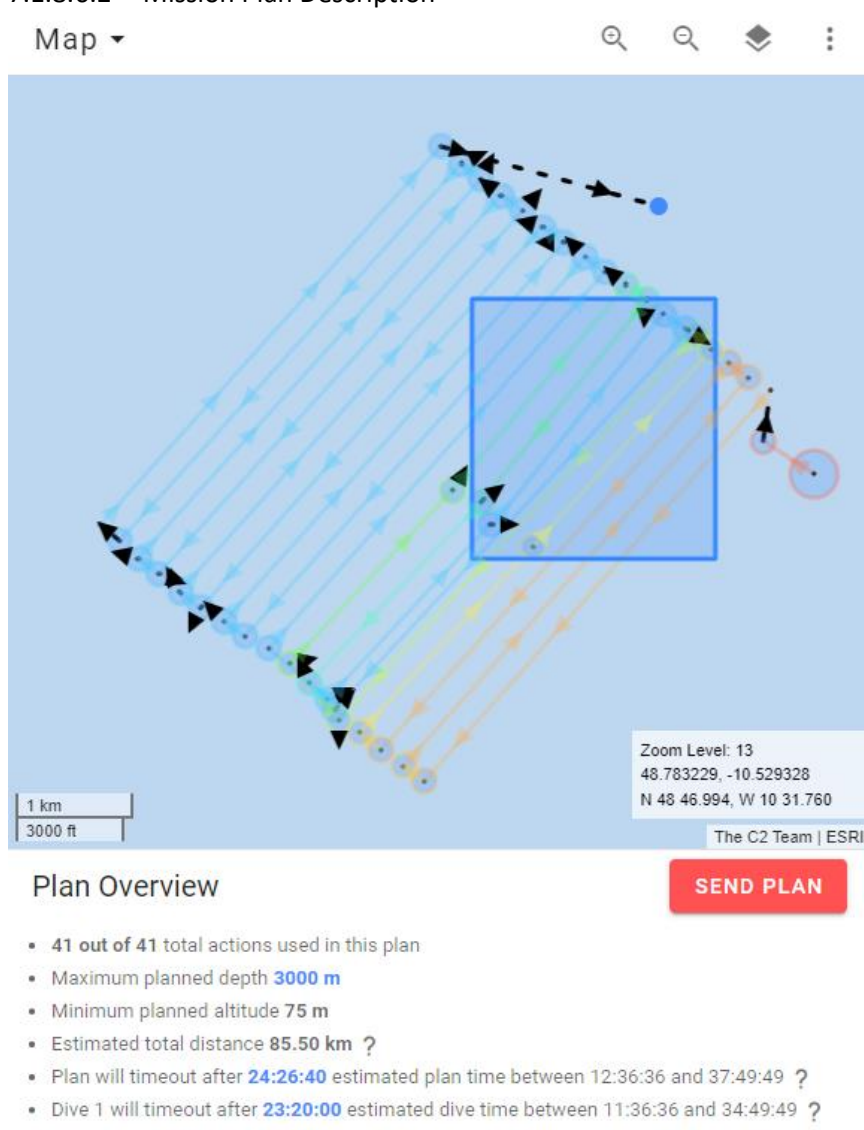

Fig. 7.40 Screenshot of planning module layout for A5M34

7.1.8.6.2.1 System Spec

Table 7.25 AUV system specs for A5M35

Wings	-3 degrees, middle position
Estimated Battery Use	23 KWh

7.1.8.6.2.2 Navigation

Navigation Solution	Localiser
USBL Telemetry	Required

7.1.8.6.2.3 OCS Critical Parameters Spec

Table 7.27 OCS parameter specifications for A5M35

Parameter	Value
No_contact_timer	24 hours
Safety_min_alt	15m
Safety_max_depth	4500m
Iridium_period	5 mins

7.1.8.6.2.4 Trigger Configuration

Autosub 5 Trigger Mode	Autosub5_75m_Multibeam_Main_SBP40ms
Norbit FLS Mode	N/A

7.1.8.6.2.5 Payload Settings

Table 7.29 Payload settings for A5M35

Device	Required (Y/N)	Mode
9+ CTD	Yes inc DO	N/A
AESA Camera	no	N/A
Norbit Bathy	Yes	Bathy75mAlt_400kHz_Dir0_180swath
Edgetech 2205	Yes	SSL_120_SBP_2_8_40ms for now, Veerle wants to check SBP
Wetlabs BBRT	Yes	N/A
NOC ROCSI	No	Insert name of mission csv
Applied Physics Magnetometer	Yes	N/A

7.1.8.6.2.6 ADCP/DVL Settings

Table 7.30 ADCP/DVL settings for A5M35

Setting	ALR Default Value	Requested Values
Water Track Start range(m)	8.5	1
Water Track bin width(m)	96	37.5
Number of Bins	12	150
Depth Cell Width (cm)	800	50

7.1.8.6.2.7 ROCSI Setting

Table 7.31 ROCSI Settings for A5M35

Min Depth	Max Depth	Clean	Number of samples	Litres	Time out
400	1500	1	24	2	3600

7.1.8.6.3 Mission Narrative

Due to ROV deployment precluding immediate recovery, AS5 remained on the surface overnight with short station-keeping missions until morning. No engineering data from the overnight surface adventure available due to accidental vehicle data purge.

7.1.8.6.4 Annotated Engineering Plots

Sub aborted 6 hours in to the planned 24hr mission, covering 6 multibeam legs, due to an under-min-alt abort which jettisoned the abort weight.

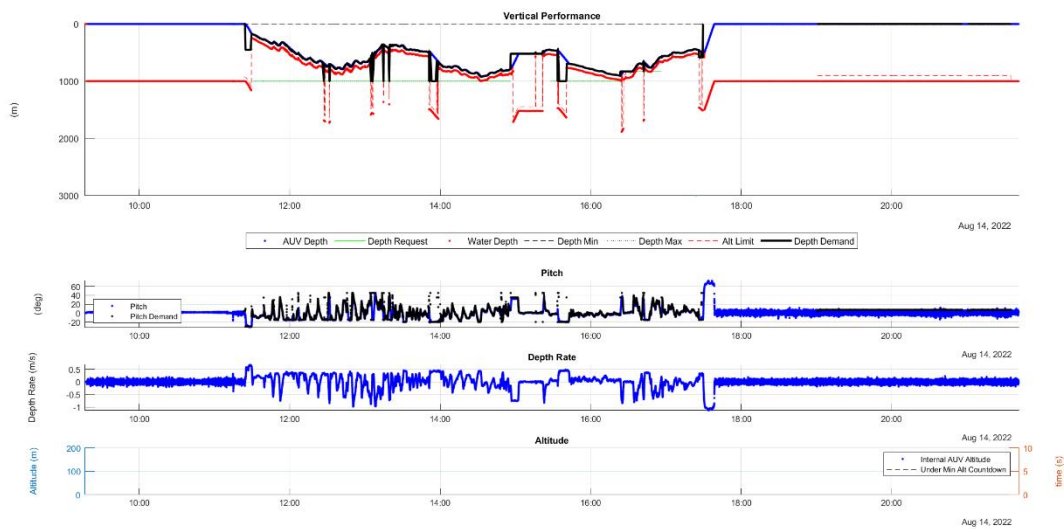

Fig. 7.41 A5M35 AUV vertical performance

AS5 was traversing deep valleys/cliff edges which prompted deeper depth demands and a loss in altitude resulted. In the example below, AS5 was able to traverse the first two shorter troughs, as it had sufficient altitude to clear the other side. But the final trough was long enough for AS5 altitude to drop sufficiently to not clear the other side sufficiently and an under-min-alt abort resulted.

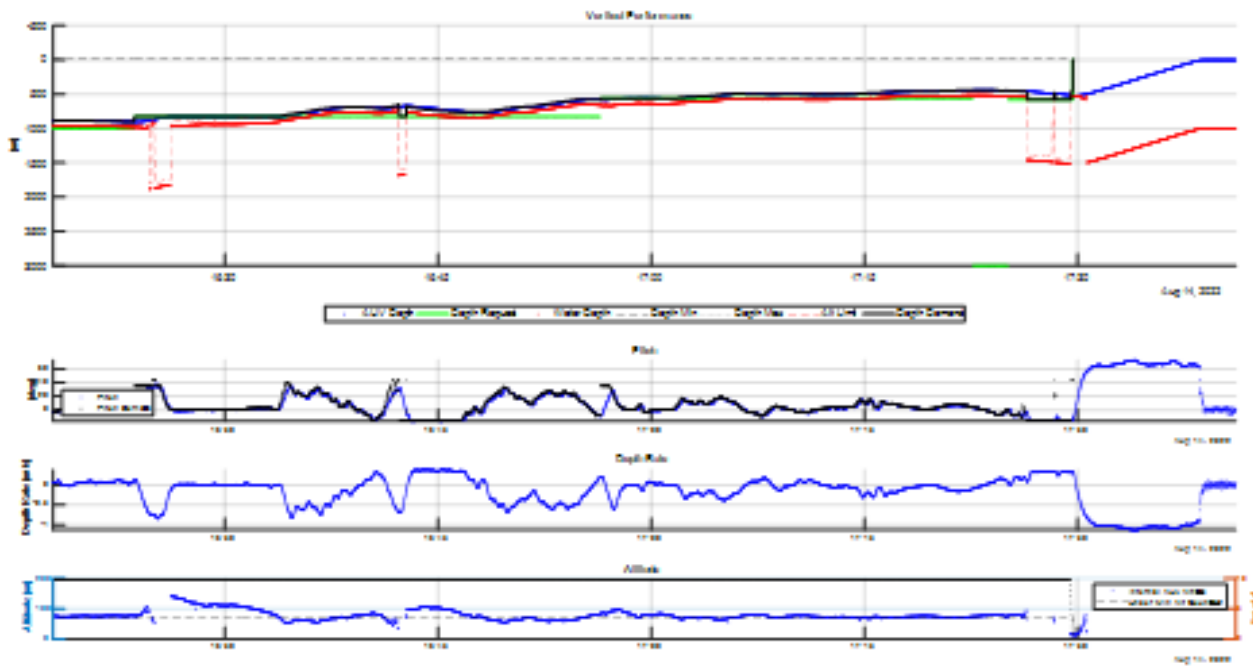

Fig. 7.42 Zoom on vertical performance data at moment of abort in A5M35

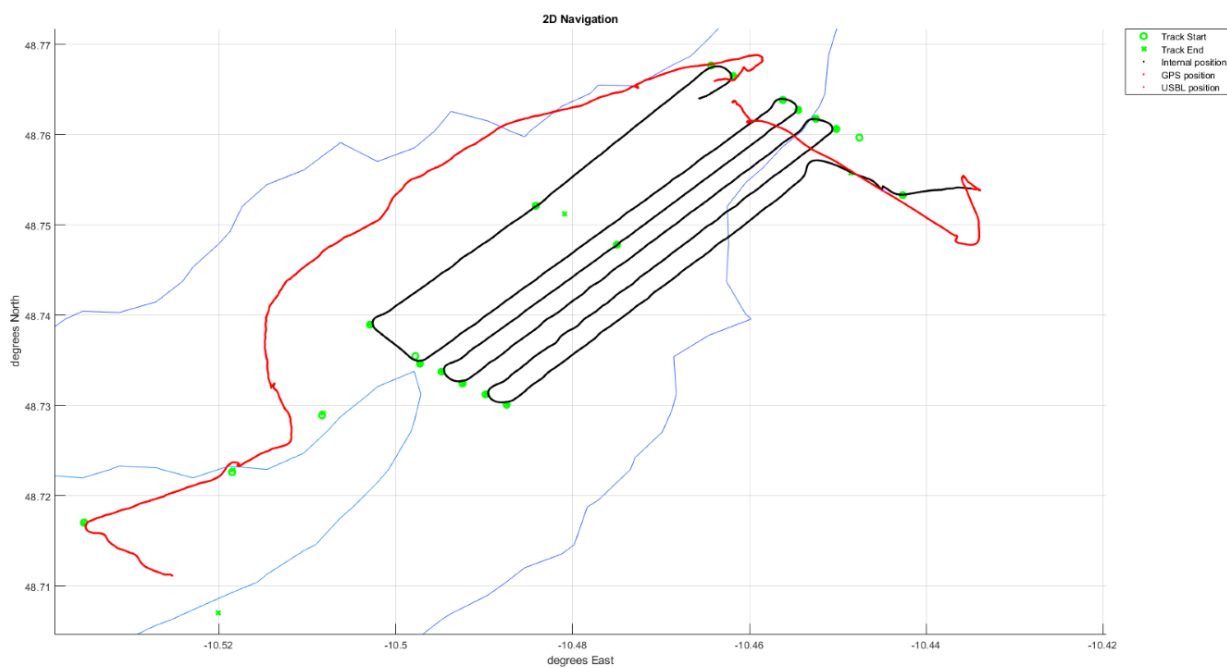

Fig. 7.43 A5M35 Mission Lines

Thruster Monitoring: engineering.pg.csv

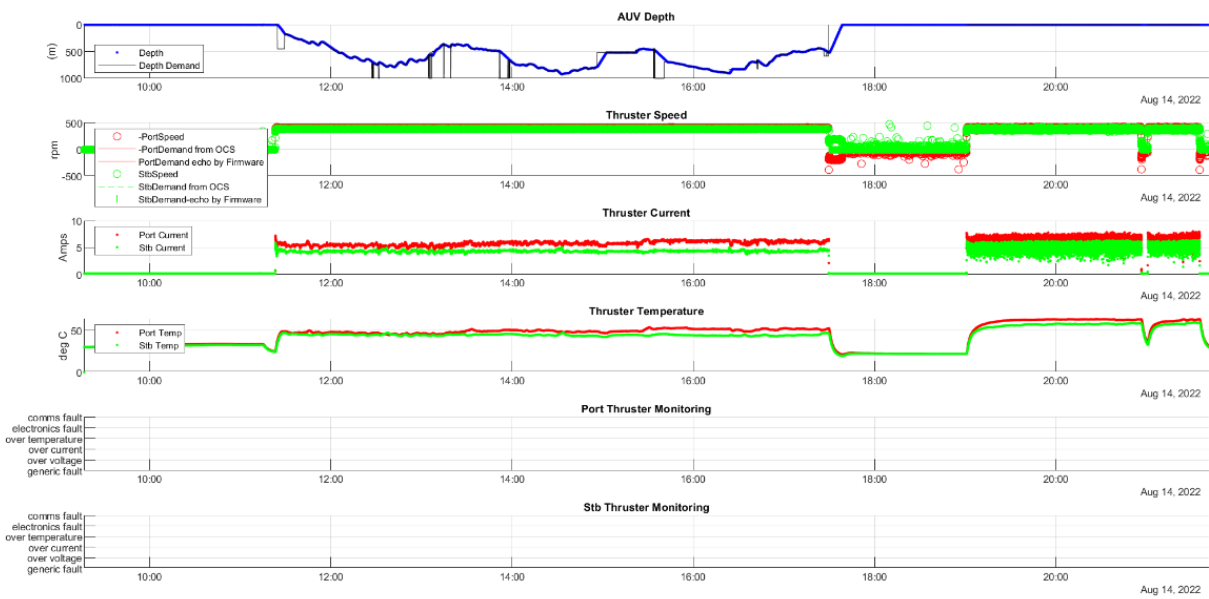

Fig. 7.44 A5M35 Thruster monitoring data

7.1.8.7. Autosub5 M36 Mission Summary

7.1.8.7.1 Mission Statistics

Table 7.32 Details of mission A5M36

Mission Identifier	A5M36
Start Time	17-Aug-2022 14:20:12
Time Elapsed	0.95972 Hrs
Distance Travelled	3.8934 Km
Start Coordinates	48.7652 deg N, -10.4523 deg E
End Coordinates	48.7543 deg N, -10.4719 deg E
Max Depth	561.6837 meters
Minimum Altitude Recorded	1.05m
Start Battery Voltage / Start State of Charge	57.984V / 97.5%
End Battery Voltage / End State of Charge	57.546V / 92.5%

7.1.8.7.2 Mission Plan Description

The screenshot displays a mission planning interface. At the top, there is a 'Map' dropdown menu and navigation icons. The main area shows a map with a planned route consisting of several waypoints connected by lines. A dashed line indicates the primary path, while other lines represent alternative routes. Below the map, there is a scale bar showing 500 m and 2000 ft. A status box provides the following information: Zoom Level: 14, coordinates 48.754604, -10.451589, and N 48 45.276, W 10 27.095. At the bottom left, there is a 'Plan Overview' section with a list of mission parameters. At the bottom right, there is a red 'SEND PLAN' button.

Plan Overview

- 40 out of 41 total actions used in this plan
- Maximum planned depth 1500 m
- Minimum planned altitude 30 m
- Estimated total distance 14.73 km ?
- Plan will timeout after 08:20:00 estimated plan time between 02:48:10 and 08:24:31 ?
- Dive 1 will timeout after 08:20:00 estimated dive time between 01:48:10 and 05:24:31 ?

Fig. 7.45 Screenshot of planning module layout for A5M36

7.1.8.7.2.1 System Spec

Table 7.33 AUV system specs for A5M36

Wings	-3 degrees, middle position
Estimated Battery Use	5 KWh

7.1.8.7.2.2 Navigation

Table 7.34 AUV Navigation settings for A5M36

Navigation Solution	Localiser
USBL Telemetry	Required

7.1.8.7.2.3 OCS Critical Parameters Spec

Table 7.35 OCS parameter specifications for A5M36

Parameter	Value
No_contact_timer	24 hours
Safety_min_alt	15m
Safety_max_depth	4500m
Iridium_period	5 mins

7.1.8.7.2.4 Trigger Configuration

Table 7.36 Trigger Configuration for A5M36

Autosub 5 Trigger Mode	Autosub5_75m_Multibeam_Main_SBP40ms
Norbit FLS Mode	N/A

7.1.8.7.2.5 Payload Settings

Table 7.37 Payload settings for A5M36

Device	Required (Y/N)	Mode
9+ CTD	Yes inc DO	N/A
AESA Camera	no	N/A
Norbit Bathy	Yes	Bathy75mAlt_400kHz_Dir0_180swath
Edgetech 2205	Yes	SSL_120_SBP_2_8_40ms
Wetlabs BBRT	Yes	N/A
NOC ROCSI	Maybe	M36RoCSII.csv
Applied Physics Magnetometer	No – Unplugged for GND Fault testing	N/A

7.1.8.7.2.6 ADCP/DVL Settings

Table 7.38 ADCP/DVL settings for A5M36

Setting	ALR Default Value	Requested Values
Water Track Start range(m)	8.5	1
Water Track bin width(m)	96	37.5
Number of Bins	12	150
Depth Cell Width (cm)	800	50

7.1.8.7.2.7 ROCSI Settings

Table 7.39 ROCSI Settings for A5M36

Min Depth,	Max Depth	Clean	Number of samples	of Litres	Time out
600	1500	0	1	2	3600

7.1.8.7.3 Mission Narrative

On Mission 36, we returned to the Acesa Walls area that we surveyed on M34. The Goal was to dive at the north east tops of the canyon and descend into the deepest parts. Using a map generated by the A5M34 multibeam survey, a carefully planned mission was made, using short, deliberate track following lines and a mix of altitude and depth control. The goal of the mission was to collect a multibeam survey of the canyon’s 300 metre vertical walls, making passes of the walls without bottom lock and using the ship’s USBL to aid navigation.

This was a short mission with the intention that the sub would surface and be sent M37 over wifi.

The mission ended in sudden failure. Noise on the DVL (possibly by two beams seeing a canyon wall and two beams seeing water column only) caused a false positive altitude reading of 0 metres. This triggered the sub’s min alt event and the sub aborted.

The sub was quickly recovered, the engineering logs were reviewed and the sub was deployed again on the same day.

7.1.8.7.4 Annotated Engineering Plots

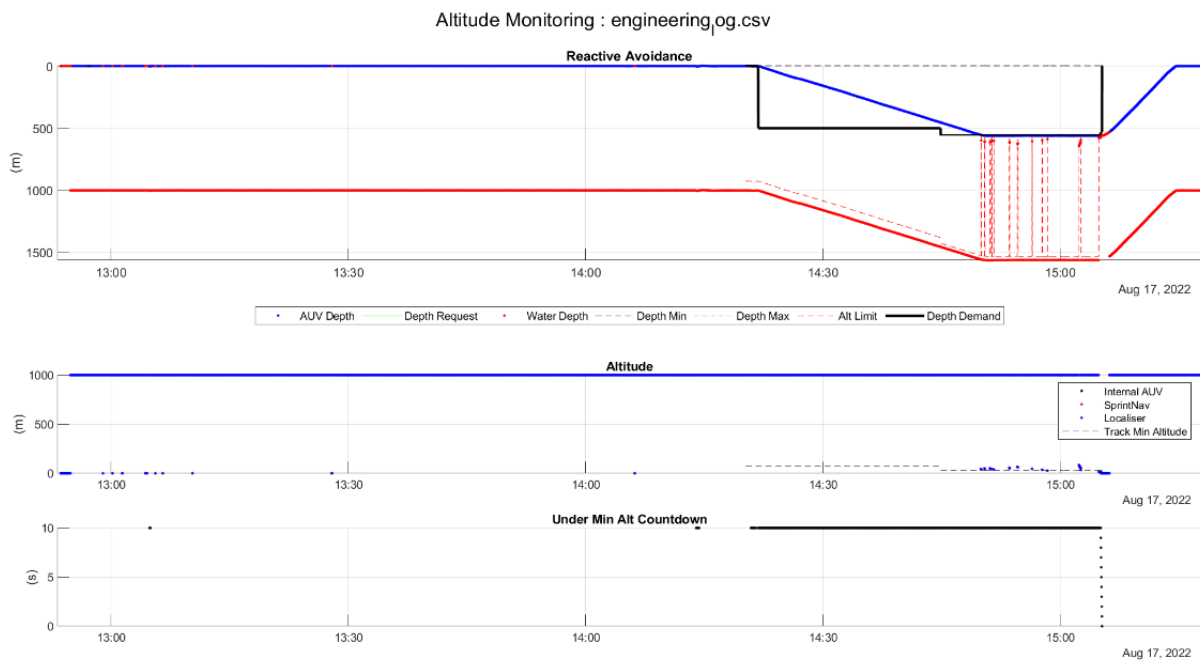

Fig. 7.46 Altitude Monitoring on A5M36. Note the sudden shift from 1000 m altitude to near zero. This is noise

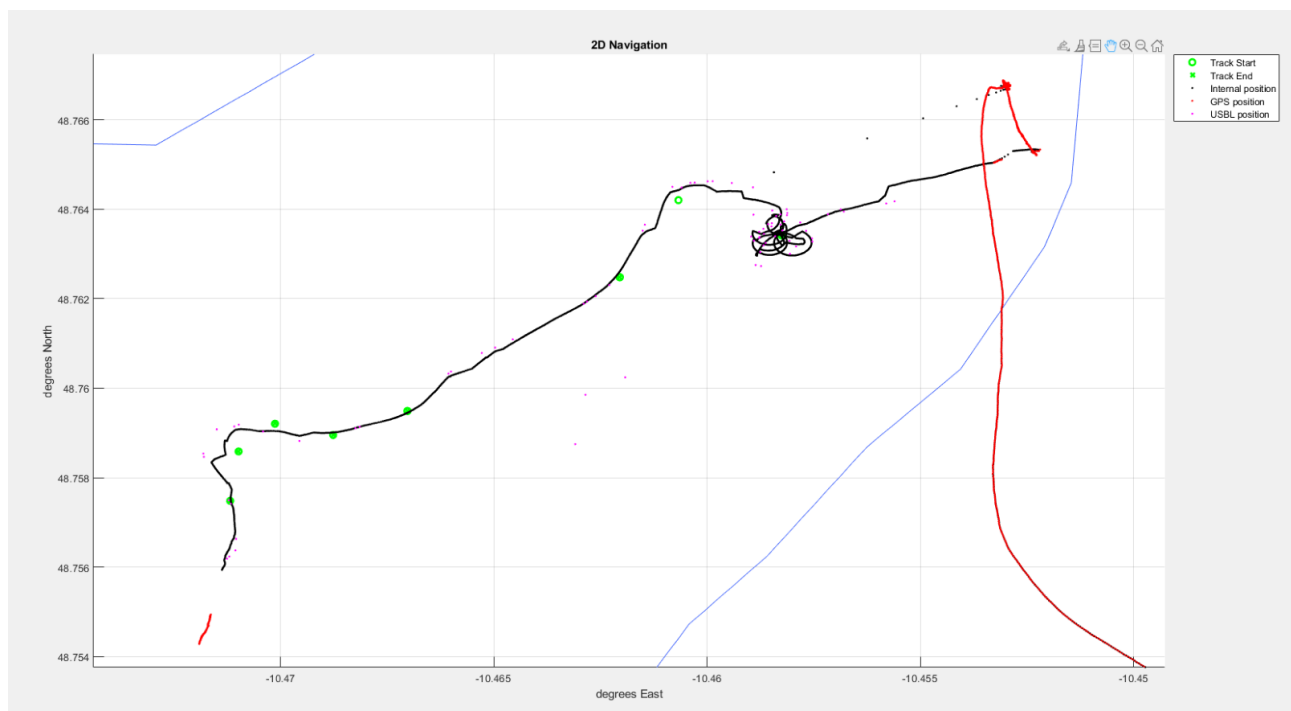

Fig. 7.47 2D Navigation of Mission A5M36.

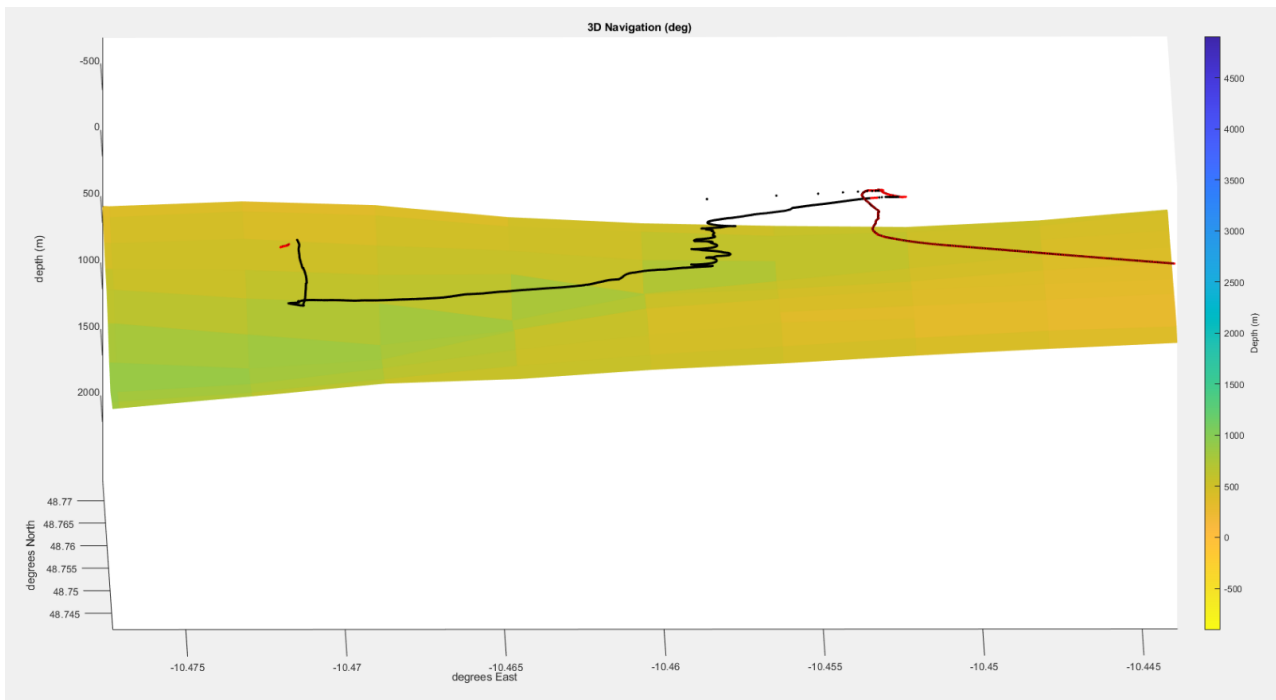

Fig. 7.48 2D plot of A5M36

7.1.8.8. Autosub5 M37 Mission Summary

7.1.8.8.1 Mission Statistics

Table 7.40 Details of mission A5M37

Mission Identifier	A5M37
Start Time	17-Aug-2022 12:53:15
Time Elapsed	22.0211 Hrs
Distance Travelled	82.7818 Km
Start Coordinates	48.7422 deg N, -10.4822 deg E
End Coordinates	48.7355 deg N, -10.5065 deg E
Max Depth	900.6398 meters
Minimum Altitude Recorded	0.2m
Start Battery Voltage / Start State of Charge	58.048V / 97.5%
End Battery Voltage / End State of Charge	51.276V / 40%

7.1.8.8.2 Mission Plan Description

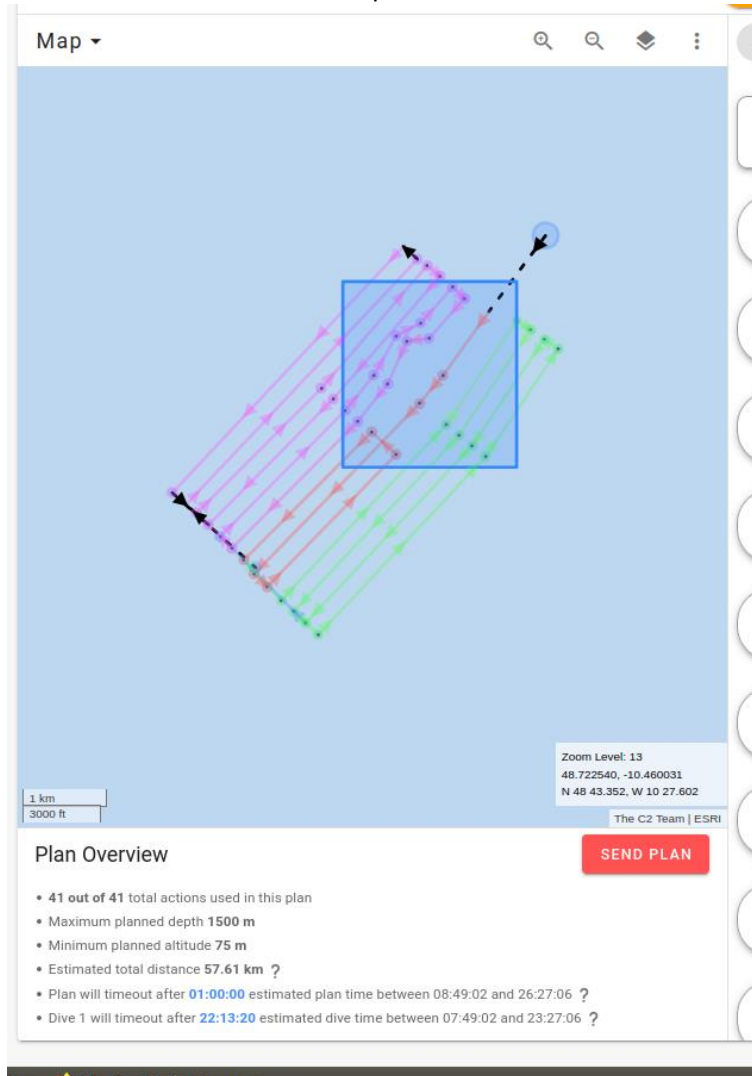

Fig. 7.49 Screenshot of planning module layout for A5M37

Objectives:

- Collect multibeam data of the canyon walls
- Low frequency sidescan and sub bottom Maybe?
- Collect 24 ROCSII samples

7.1.8.8.2.1 System Spec

Table 7.41 AUV system specs for A5M37

Wings	-3 degrees, middle position
Estimated Battery Use	5 KWh

7.1.8.8.2.2 Navigation

Table 7.42 AUV Navigation settings for A5M37

Navigation Solution	Localiser
USBL Telemetry	Required

7.1.8.8.2.3 OCS Critical Parameters Spec

Table 7.43 OCS parameter specifications for A5M37

Parameter	Value
No_contact_timer	24 hours
Safety_min_alt	15m
Safety_max_depth	4500m
Iridium_period	5 mins

7.1.8.8.2.4 Trigger Configuration

Table 7.44 Trigger Configuration for A5M37

Autosub 5 Trigger Mode	Autosub5_100m_Multibeam_Main_SBP40ms
Norbit FLS Mode	N/A

7.1.8.8.2.5 Payload Settings

Table 7.45 Payload settings for A5M37

Device	Required (Y/N)	Mode
9+ CTD	Yes inc DO	N/A
AESA Camera	no	N/A
Norbit Bathy	Yes	Bathy75mAlt_400kHz_Dir0_180swath
Edgetech 2205	Yes	SSL_120_SBP_2_8_40ms
Wetlabs BBRT	Yes	N/A
NOC ROCSI	Maybe	M36RoCSII.csv?????
Applied Physics Magnetometer	No – Unplugged for GND Fault testing	N/A

7.1.8.8.2.6 ADCP/DVL Settings

Table 7.46 ADCP/DVL settings for A5M37

Setting	ALR Default Value	Requested Values
Water Track Start range(m)	8.5	1
Water Track bin width(m)	96	37.5
Number of Bins	12	75
Depth Cell Width (cm)	800	100

7.1.8.8.2.7 ROCSI Settings

Table 7.47 ROCSI Settings for A5M37

Min Depth	Max Depth	Clean	Number of samples	Litres	Time out
600	1500	0	1	2	3600

7.1.8.8.3 Mission Narrative

We launched the sub on mission 37, aided it until it reached bottom lock then we released the ship to the scientists as we were behind schedule for the ROV dive. All this took 20 minutes. The sea state was chopper than any previous mission, which probably caused a repeat of the known Dive Timeout Reset Bug. This Bug occurs when the Sub detects itself going to a depth below the “surface zone” and then returns to a depth

inside the “surface zone”. This can happen in a large swell as bottom and the top of a wave can cross this Surface zone line.

After 30 minutes below the surface the sub reached its dive timeout. By that time we had steamed away. We would not realise our error until we were 10 nm away. We could not take any more time from the ROV dive so we decided to split the mission into smaller missions that could be sent via iridium (email).

Note that the C2 send mission over iridium feature was not working at this time, so we sent via email, the same way we sent missions the night of A5M35.

Below are the figures of the C2 mission plans sent, the 2D and vertical Navigation of the mission and the difference between the SprintNav and Localiser. Due to the depth of the Acesta Wall Canyon, 500 m at the highest point, there was plenty of navigational error that had to be corrected in the post processing of the Multibeam and Sidescan data.

However, being able to remotely recover from the Dive Timeout bug and continue the mission without forcing the ROV back on deck was a huge win for the ship.

Following the events of this night, we shortened the Dive timeout to 10 minutes and we added a countdown time to our deployment procedure. The shorter timeout will tell us sooner if there is an issue and the countdown timer covers us from mistakenly leaving the site before the timeout would have a chance to trigger.

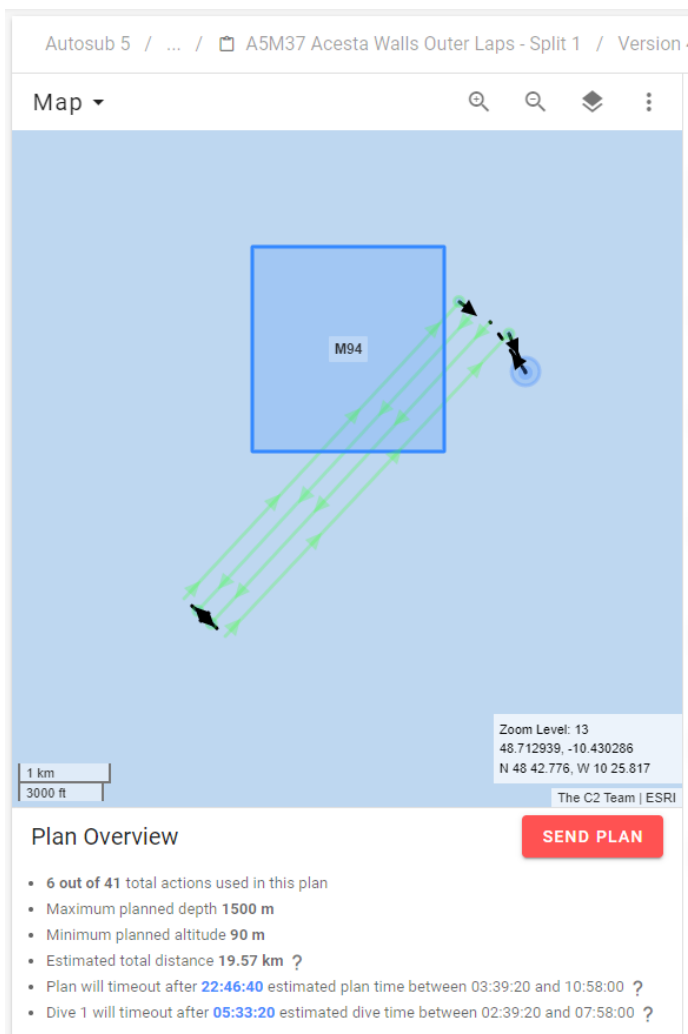

Fig. 7.50 Mission 37 split 1. <https://piloting.c2/alr-51/plan/170-4>

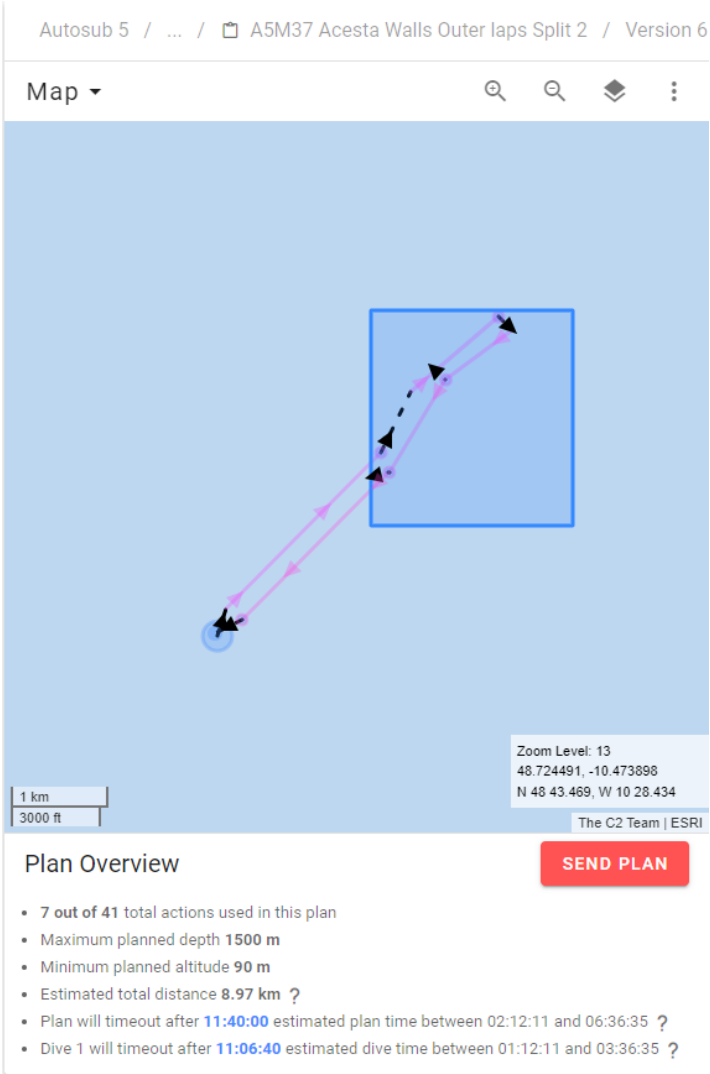

Fig. 7.51 Mission 37 split 2. <https://piloting.c2/alr-51/plan/172-6>

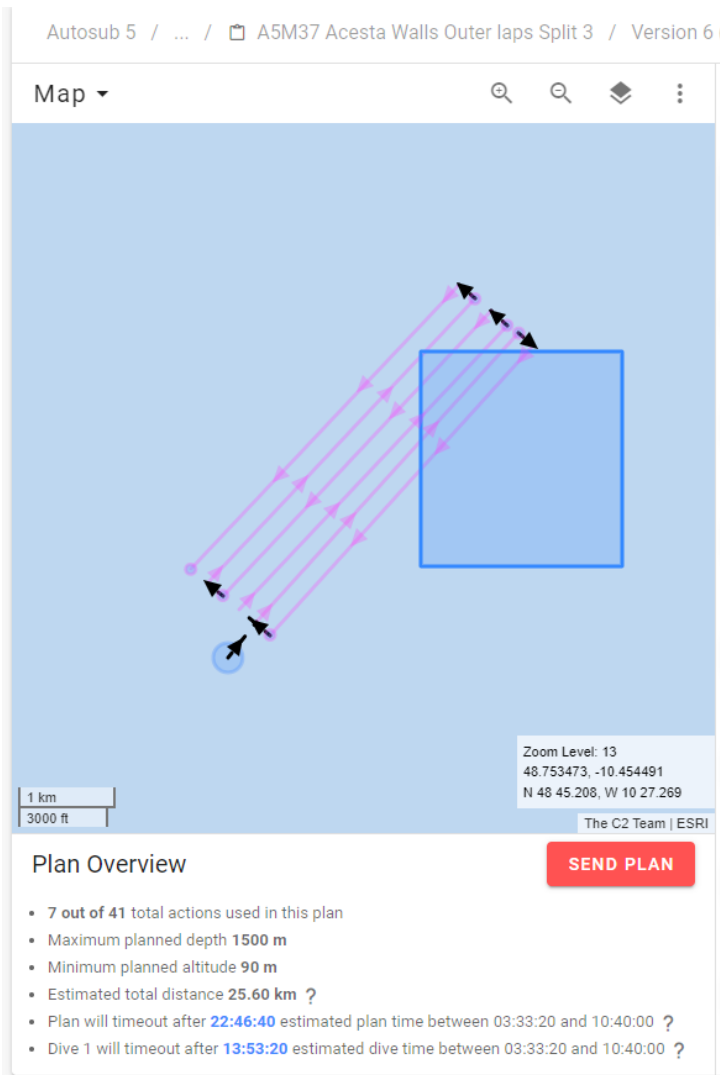

Fig. 7.52 Mission 37 split 3. <https://piloting.c2/alr-51/plan/173-6>

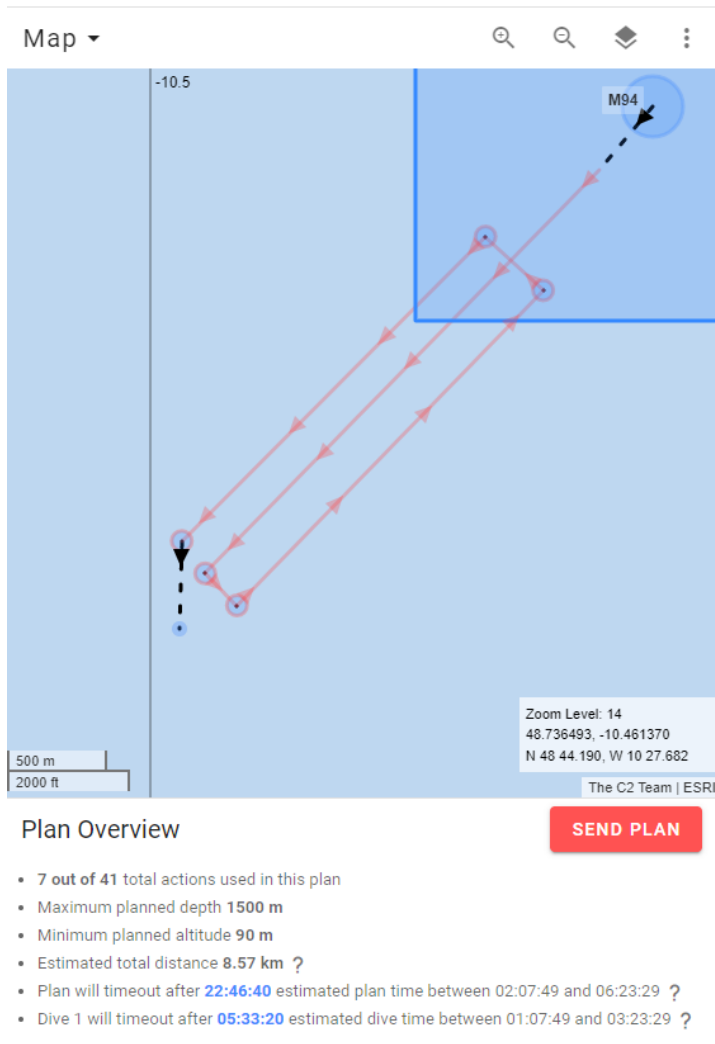

Fig. 7.53: Mission 37. Split 4 <https://piloting.c2/alr-51/plan/175-7>

7.1.8.8.4 Annotated Engineering Plots

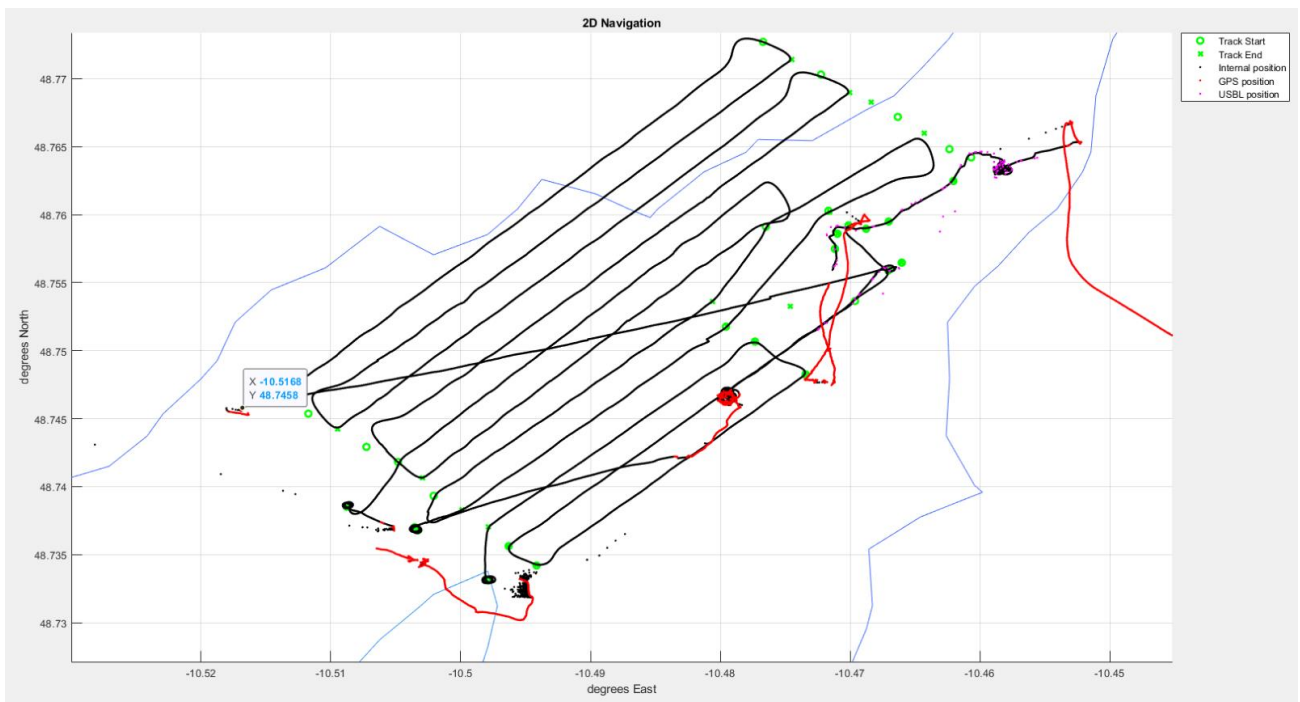

Fig. 7.54 Mission 37 2D Navigation

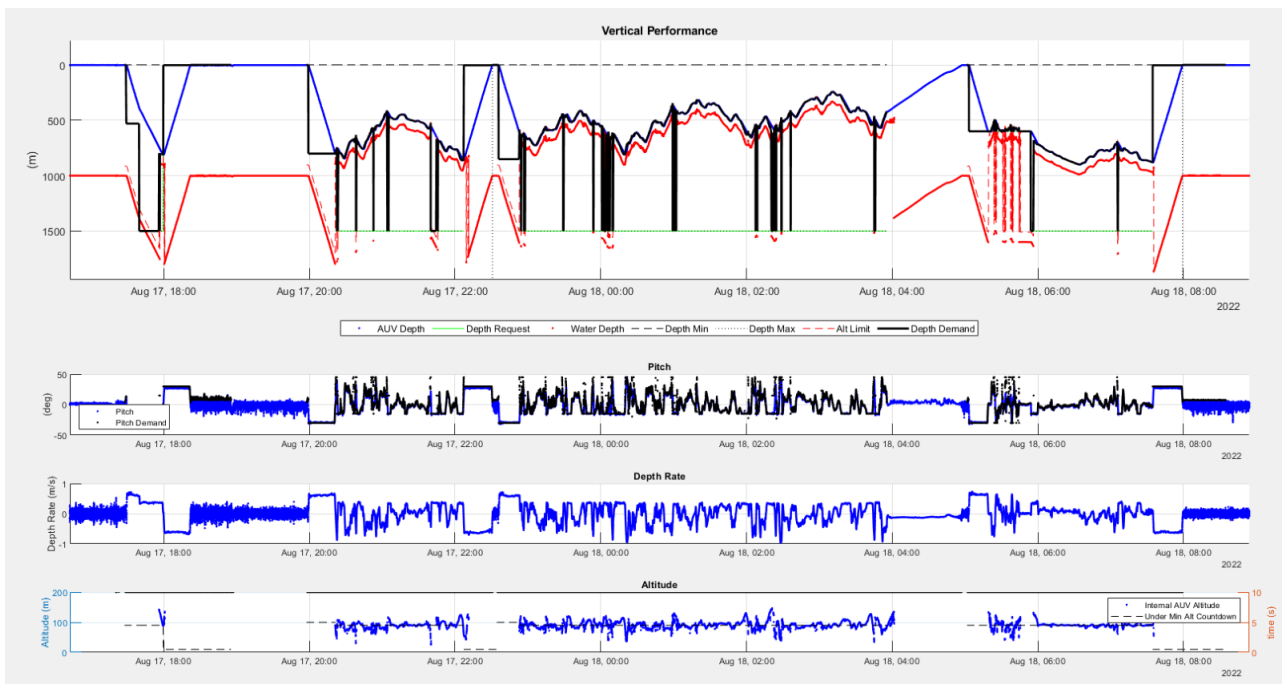

Fig. 7.55 A5M37 Vertical Performance

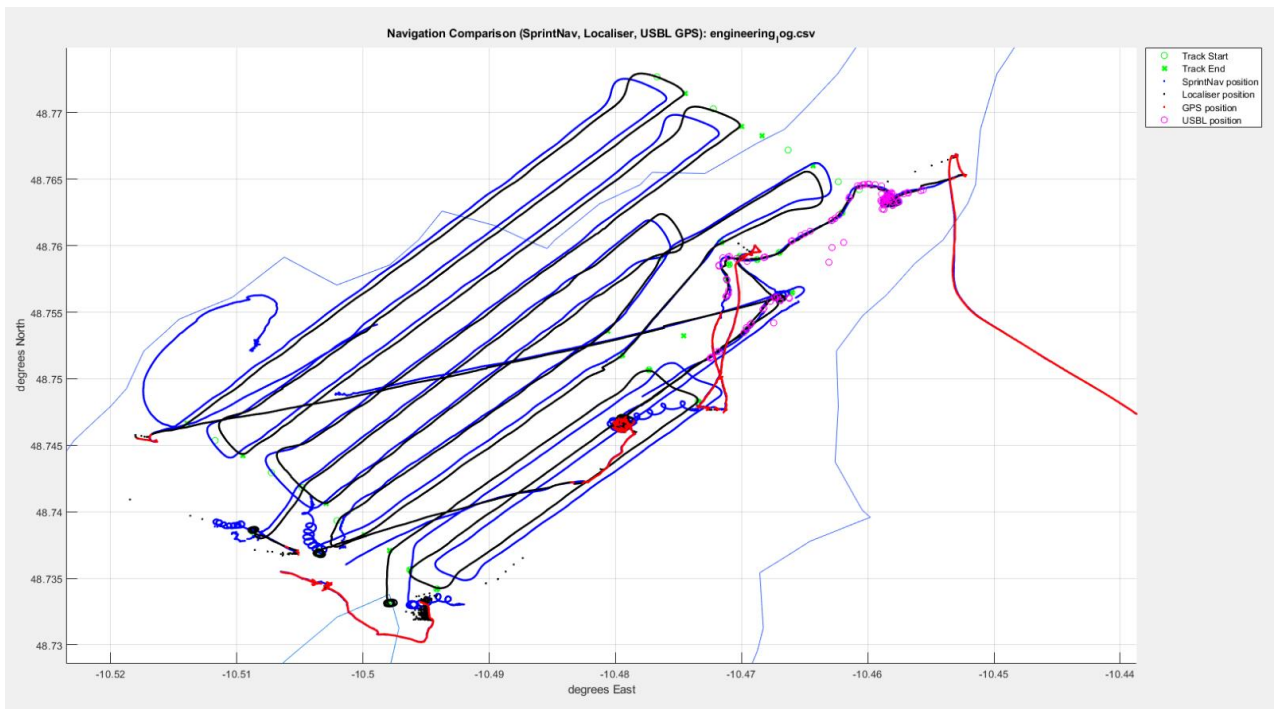

Fig. 7.56 Difference in Navigation in A5M37. Note that many of the dives had no USBL Aiding

7.1.8.9. Autosub5 M38 Mission Summary

7.1.8.9.1 Mission Statistics

Table 7.48 Details of mission A5M38

Mission Identifier	A5M38
Start Time	18-Aug-2022 13:42:37
Time Elapsed	2.3028 Hrs
Distance Travelled	9.9124 Km
Start Coordinates	48.7669 deg N, -10.4559 deg E
End Coordinates	48.7533 deg N, -10.4653 deg E
Start Battery Voltage / Start State of Charge	53.378V / 54.5%
End Battery Voltage / End State of Charge	52.14V / 47.5%

7.1.8.9.2 Mission Plan Description



Fig. 7.57 Screenshot of planning module layout for A5M38

7.1.8.9.2.1 System Spec

Table 7.49 AUV system specs for A5M38

Wings	-3 degrees, middle position
Estimated Battery Use	5 KWh

7.1.8.9.2.2 Navigation

Table 7.50 AUV Navigation settings for A5M38

Navigation Solution	Localiser
USBL Telemetry	Required

7.1.8.9.2.3 OCS Critical Parameters Spec

Table 7.51 OCS parameter specifications for A5M38

Parameter	Value
No_contact_timer	24 hours
Safety_min_alt	15m
Safety_max_depth	4500m
Iridium_period	5 mins
Default_Dive_timeout	10 mins

7.1.8.9.2.4 Trigger Configuration

Table 7.52 Trigger Configuration for A5M38

Autosub 5 Trigger Mode	Autosub5_100m_Multibeam_Main_SBP40ms
Norbit FLS Mode	N/A

7.1.8.9.2.5 Payload Settings

Table 7.53 Payload settings for A5M38

Device	Required (Y/N)	Mode
9+ CTD	Yes inc DO	N/A
AESA Camera	no	N/A
Norbit Bathy	Yes	Bathy75mAlt_400kHz_Dir0_180
Edgetech 2205	Yes	SSL_120_SBP_2_8_40ms
Wetlabs BBRT	Yes	N/A
NOC ROCSI	yes	m36RoCSII.csv
Applied Physics Magnetometer	No – Unplugged for GND Fault testing	N/A

7.1.8.9.2.6 ADCP/DVL Settings

Table 7.54 ADCP/DVL settings for A5M38

Setting	ALR Default Value	Requested Values
Water Track Start range(m)	8.5	1
Water Track bin width(m)	96	37.5
Number of Bins	12	75
Depth Cell Width (cm)	800	100

7.1.8.9.2.7 ROCSI Setting

Table 7.55 ROCSI Settings for A5M38

Min Depth	Max Depth	Clean	Number of samples	Litres	Time out
600	1500	0	1	2	3600

7.1.8.9.3 Mission Narrative

The plan was to repeat the AS5M036 survey of the Acesa Canyon, but in reverse. The AUV would collect multibeam and side scan data of the canyon walls. This would require the AUV to fly without bottom lock, so the Ship was used to provide navigation aiding. The mission ended after during the second laps of the canyon due to an under-min alt abort created by a false DVL ping.

7.1.8.9.4 Annotated Engineering Plots

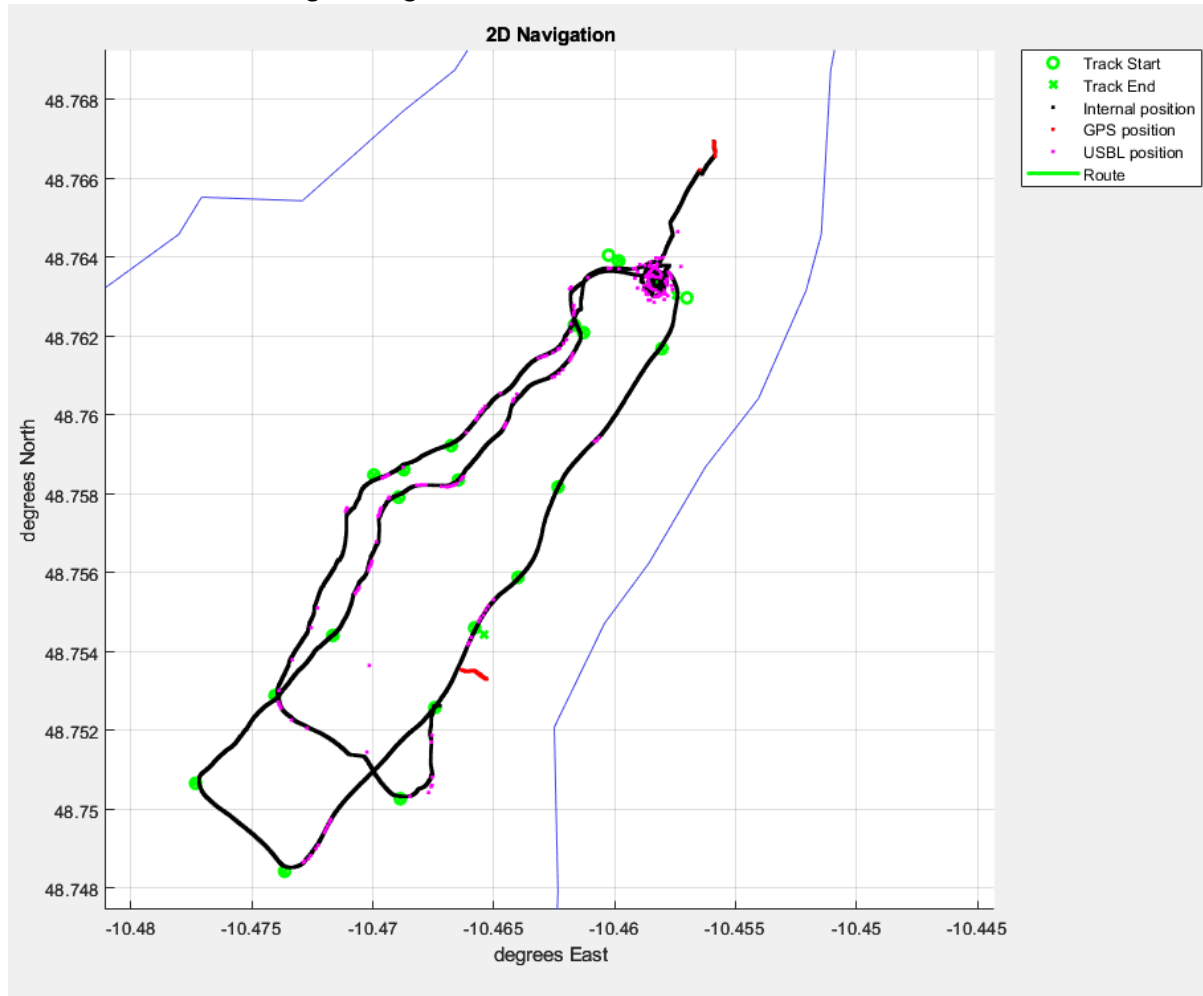

Fig. 7.58 2D navigation plot of A5M38

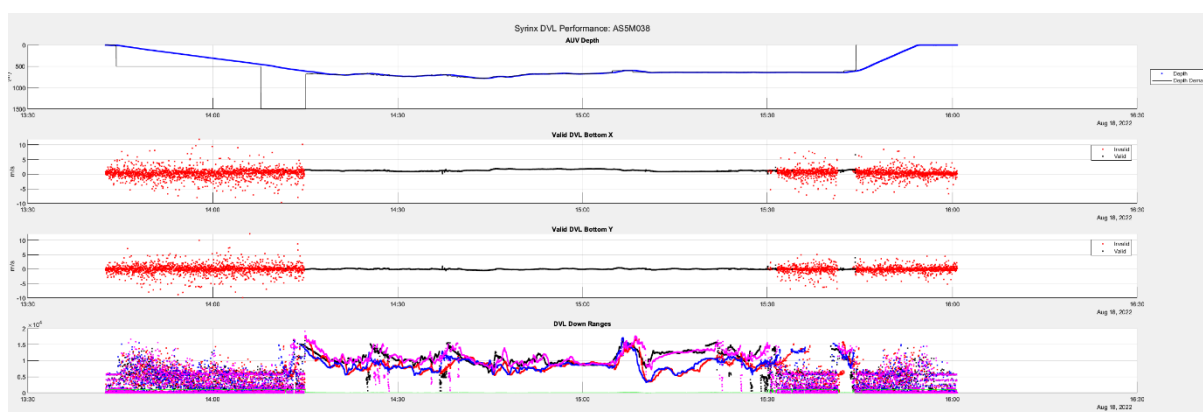

Fig. 7.59 Syrinx DVL Performance plots for A5M38

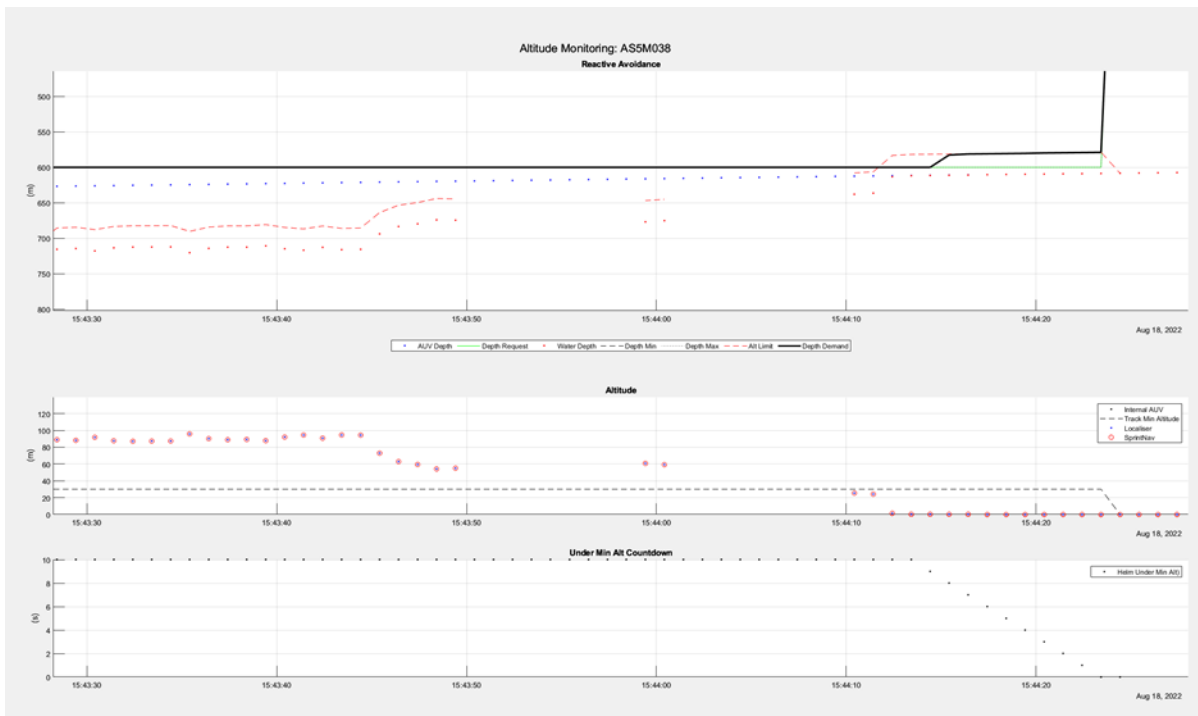

Fig. 7.60 Diagnostic plots illustrating the A5M38 under min altitude event

7.1.8.10. Autosub5 M39 Mission Summary

7.1.8.10.1 Mission Statistics

Table 7.56 Details of mission A5M39

Mission Identifier	A5M39
Start Time	20-Aug-2022 16:00:50
Time Elapsed	19.2117 Hrs
Distance Travelled	72.8971 Km
Start Coordinates	48.4116 deg N, -9.678 deg E
End Coordinates	48.3897 deg N, -9.7199 deg E
Max Depth	422.6184 meters
Minimum Altitude Recorded	0.49m
Start Battery Voltage / Start State of Charge	58.024V / 97%
End Battery Voltage / End State of Charge	50.29V / 23%

7.1.8.10.2 Mission Plan Description

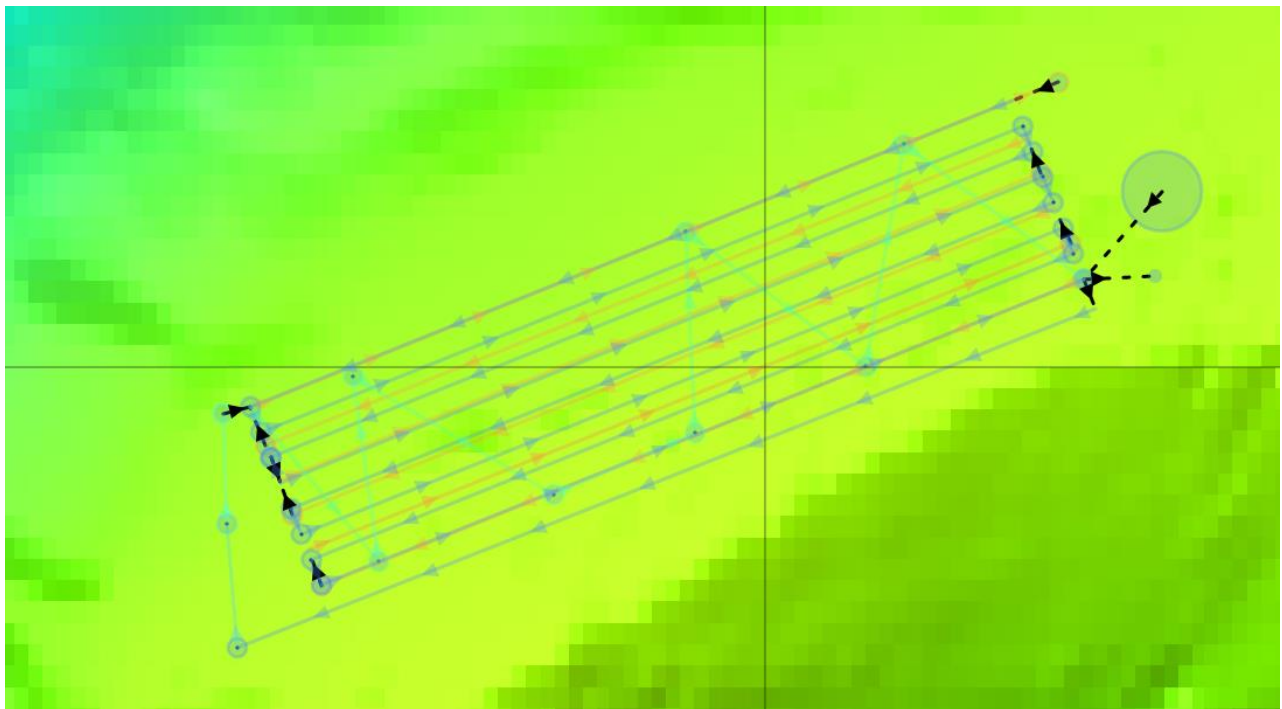

Fig. 7.61 C2 Mission Plan for A5M39

7.1.8.10.2.1 System Spec

Table 7.57 AUV system specs for A5M39

Wings	-3 degrees, middle position
Estimated Battery Use	85%

7.1.8.10.2.2 Navigation

Table 7.58 AUV Navigation settings for A5M39

Navigation Solution	Localiser
USBL Telemetry	Nice to have during the diving

7.1.8.10.2.3 OCS Critical Parameters Spec

Table 7.59 OCS parameter specifications for A5M39

Parameter	Value
No_contact_timer	24 hours
Safety_min_alt	1 m
Safety_max_depth	4500m
Iridium_period	5 mins

7.1.8.10.2.4 Trigger Configuration

Table 7.60 Trigger Configuration for A5M39

Autosub 5 Trigger Mode	
Norbit FLS Mode	Off

7.1.8.10.2.5 Payload Settings

Table 7.61 Payload settings for A5M39

Device	Required (Y/N)	Mode
9+ CTD	Yes inc DO	N/A
AESA Camera	Yes	N/A
Norbit Bathy	Yes	
Edgetech 2205	Yes	
Wetlabs BBRT	Yes	N/A
NOC ROCSI	Yes	
Applied Physics Magnetometer	No	N/A

7.1.8.10.2.6 ADCP/DVL Settings

Table 7.62 ADCP/DVL settings for A5M39

Setting	ALR Default Value	Requested Values
Water Track Start range(m)	8.5	8.5
Water Track bin width(m)	96	96
Number of Bins	12	12
Depth Cell Width (cm)	800	800

7.1.8.10.2.7 ROCSII Settings

Table 7.63 ROCSI Settings for A5M39

Min Depth	Max Depth	Clean	Number of samples	Litres	Time out
200	600	1	24	2	2400

7.1.8.10.3 Mission Narrative

The sub performed successfully the MBES and the SSS survey respectively at 50 m and 15 m. The sub aborted due to an under-min altitude event while approaching the 4 m altitude required for the camera survey. During the steps down to approach the camera survey (10 m and 7 m altitude) the sub was following the terrain that had a negative slope. A lump in the terrain made the sub abort due to the impossibility to pull up in time to maintain the safety min altitude condition satisfied.

During the mission ROCSI collected 24 samples marking the first multi-sample success in this campaign.

7.1.8.10.4 Annotated Engineering Plots

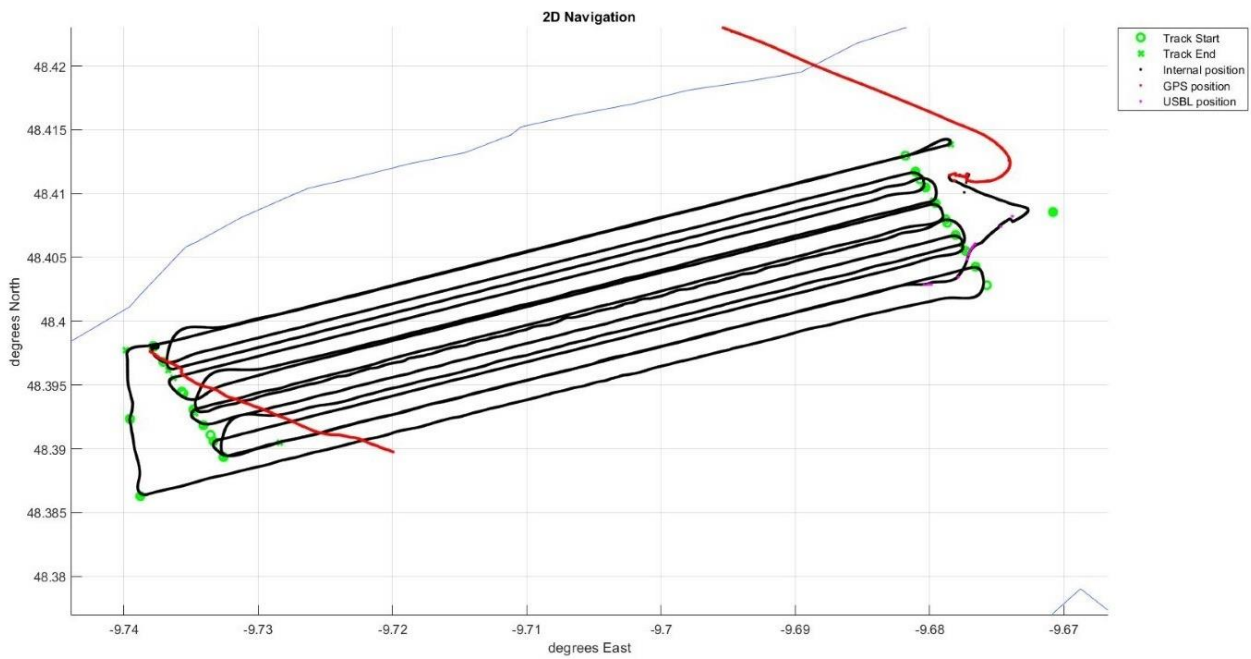

Fig. 7.62 2D Navigation plot for A5M39

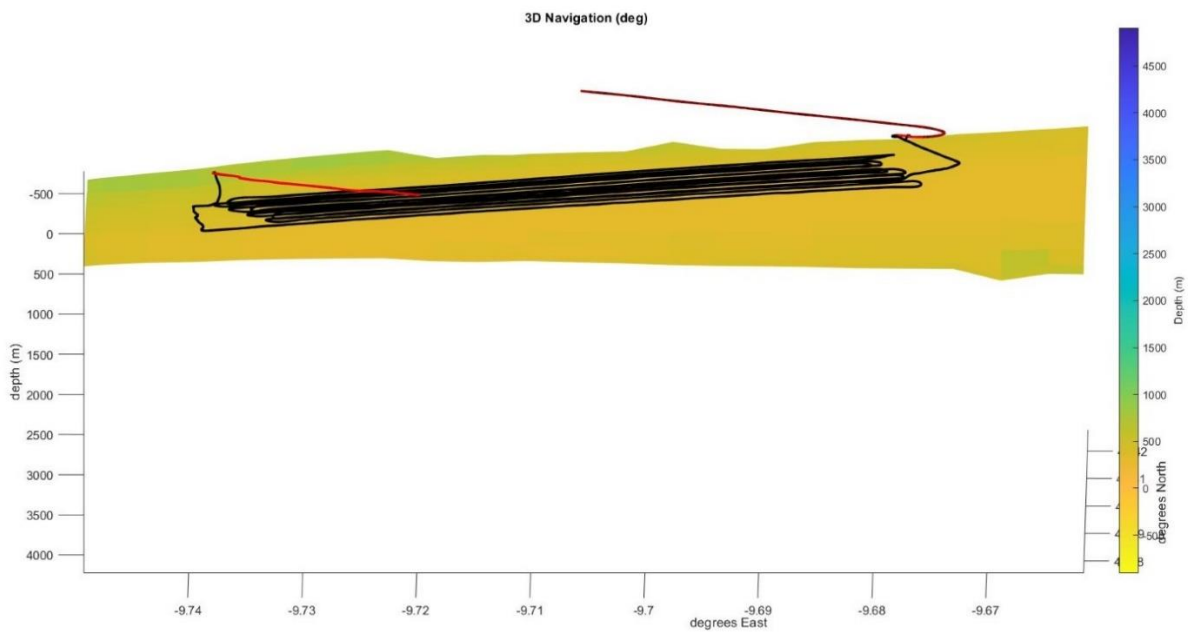

Fig. 7.63 3D Navigation plot for A5M39

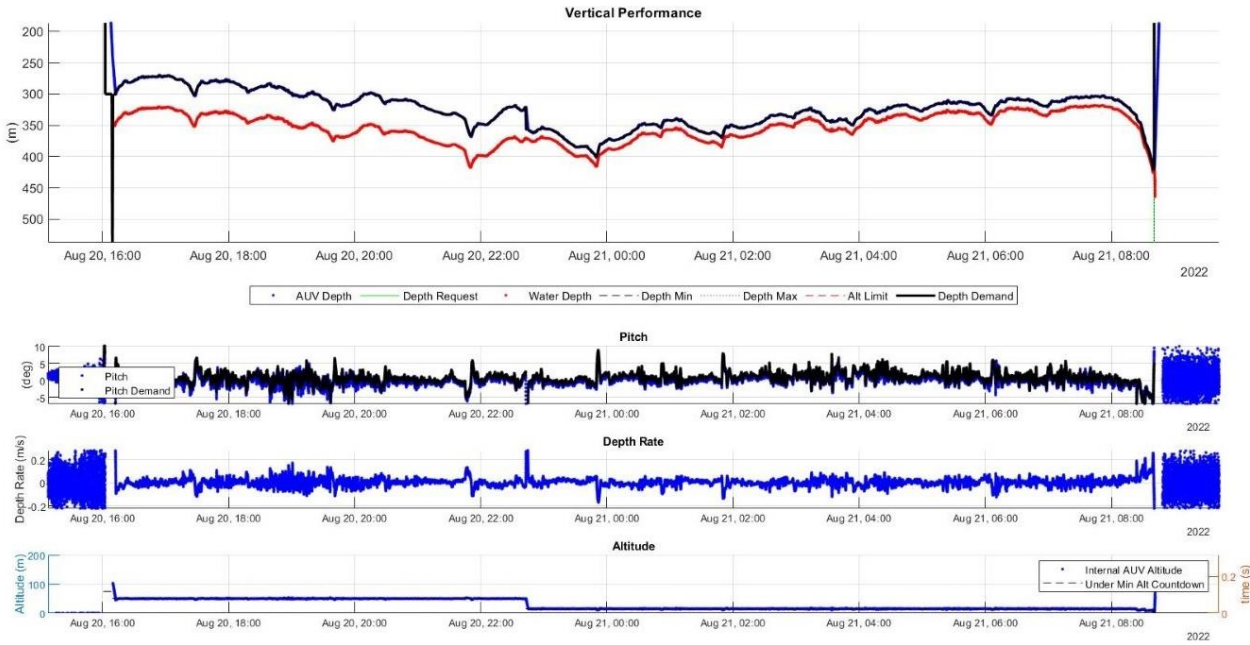

Fig. 7.64 Vertical performance plots for A5M39

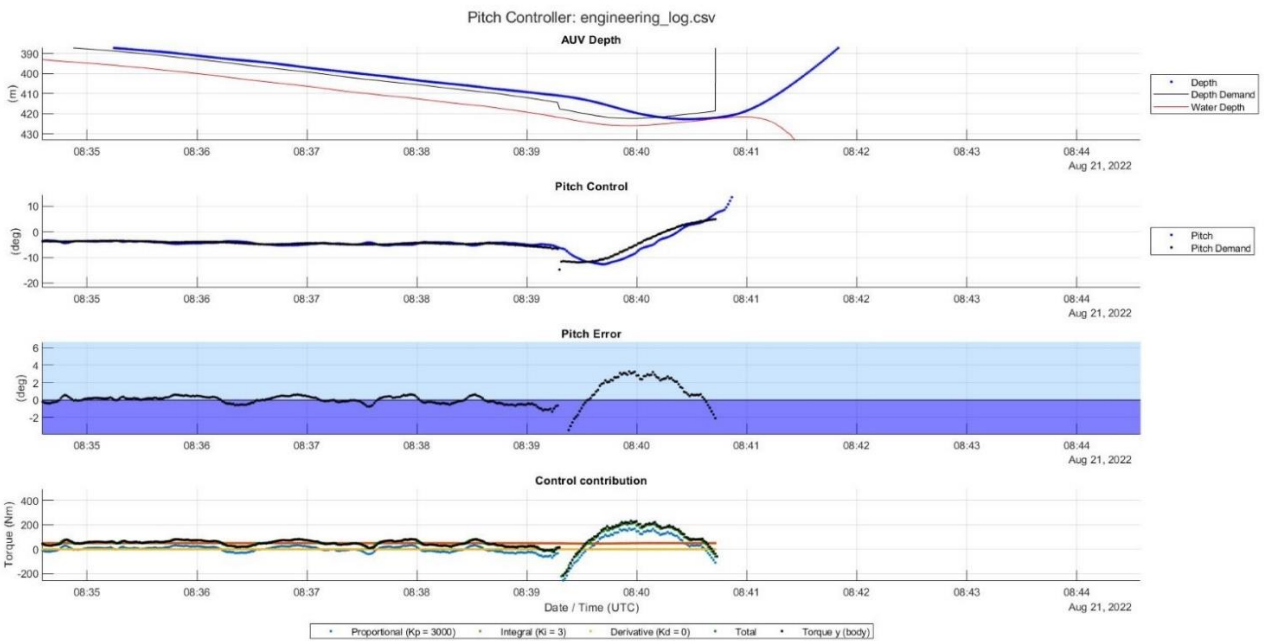

Fig. 7.65 Pitch control plots for mission A5M39

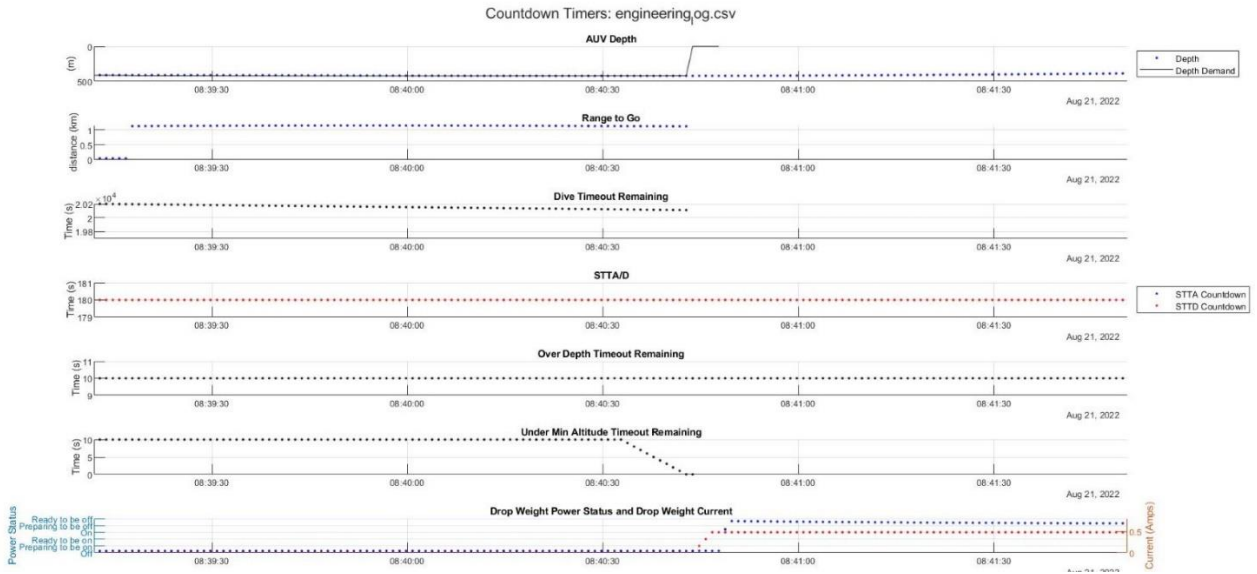

Fig. 7.66 Countdown timers for mission A5M39

These graphs illustrate the under min altitude condition leading the sub to abort.

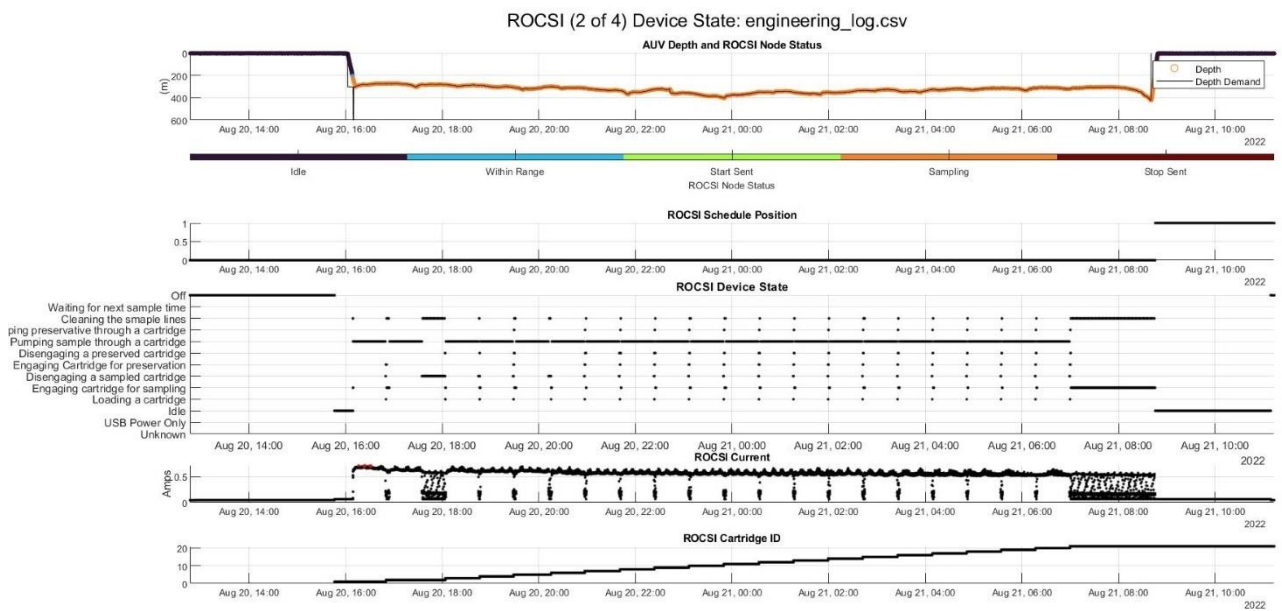

Fig. 7.67 ROCSI device state for mission A5M39

7.1.8.11. Autosub5 M040 Mission Summary

7.1.8.11.1 Mission Statistics

Table 7.64 Details of mission A5M40

Mission Identifier	A5M40
Start Time	22-Aug-2022 09:10:51
Time Elapsed	27.4492 Hrs
Distance Travelled	106.2461 Km
Start Coordinates	48.6626 deg N, -10.0268 deg E
End Coordinates	48.6981 deg N, -10.0285 deg E
Max Depth	1566.3939 meters
Minimum Altitude Recorded	24.51m
Start Battery Voltage / Start State of Charge	57.94V / 96.5%
End Battery Voltage / End State of Charge	47.08V / 7%

7.1.8.11.2 Mission Plan Description

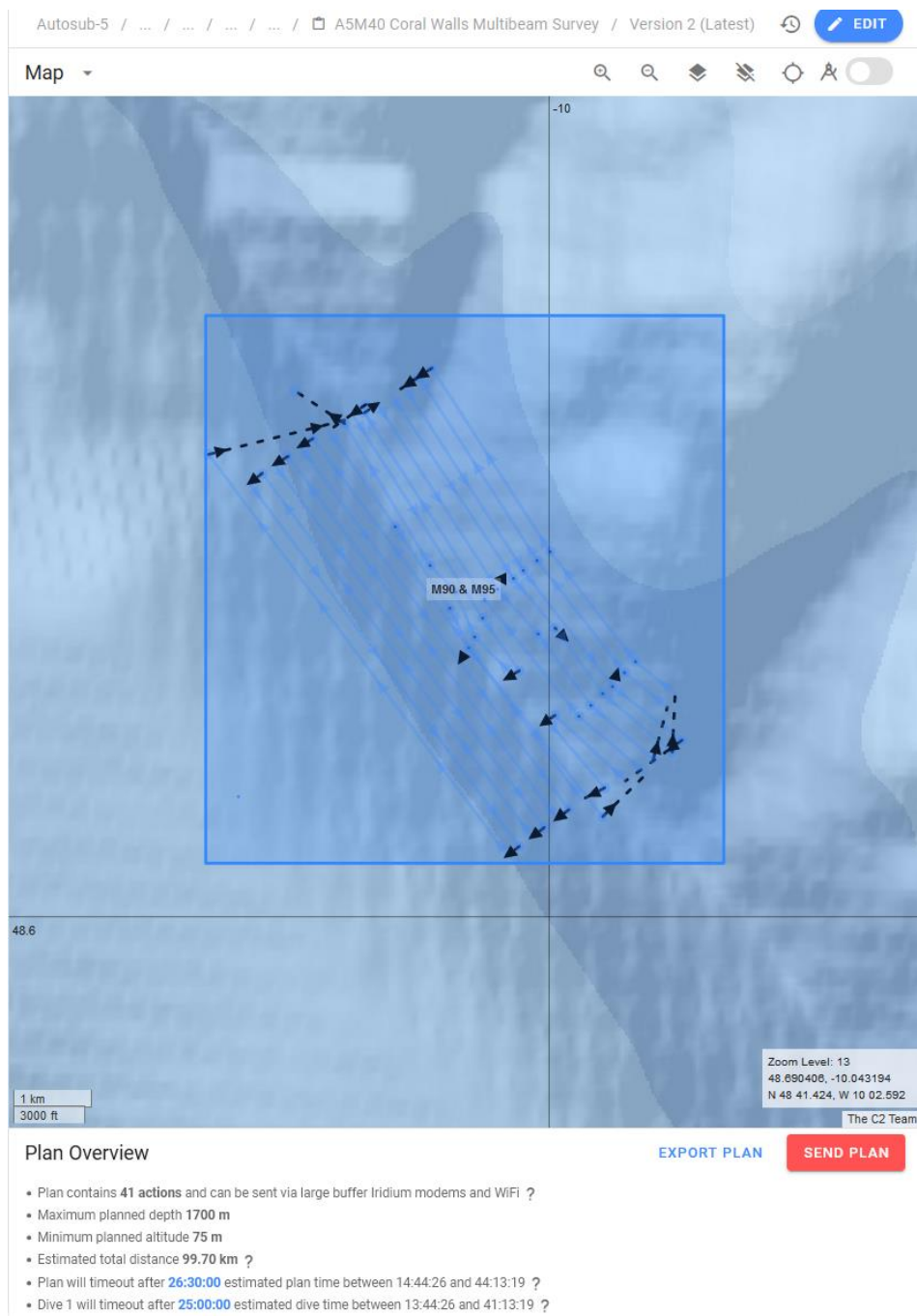

Fig. 7.68 Screenshot of planning module layout for A5M40

7.1.8.11.2.1 System Spec

Table 7.65 AUV system specs for A5M40

Wings	-3 degrees, middle position
Estimated Battery Use	25 KWh

7.1.8.11.2.2 Navigation

Table 7.66 AUV Navigation settings for A5M40

Navigation Solution	Localiser
USBL Telemetry	Required

7.1.8.11.2.3 OCS Critical Parameters Spec

Table 7.67 OCS parameter specifications for A5M40

Parameter	Value
No_contact_timer	24 hours
Safety_min_alt	15m
Safety_max_depth	4500m
Iridium_period	5 mins
Default_Dive_timeout	10 mins

7.1.8.11.2.4 Trigger Configuration

Table 7.68 Trigger Configuration for A5M40

Autosub 5 Trigger Mode	Autosub5_100m_Multibeam_Main_SBP40ms
Norbit FLS Mode	N/A

7.1.8.11.2.5 Payload Settings

Table 7.69 Payload settings for A5M40

Device	Required (Y/N)	Mode
9+ CTD	Yes inc DO	N/A
AESA Camera	no	N/A
Norbit Bathy	Yes	Bathy75mAlt_400kHz_Dir0_180
Edgetech 2205	Yes	SSL_120_SBP_2_8_40ms
Wetlabs BBRT	Yes	N/A
NOC ROCSI	No	N/A
Applied Physics Magnetometer	No – Unplugged for GND Fault testing	N/A

7.1.8.11.2.6 ADCP/DVL Settings

Table 7.70 ADCP/DVL settings for A5M40

Setting	ALR Default Value	Requested Values
Water Track Start range(m)	8.5	1
Water Track bin width(m)	96	37.5
Number of Bins	12	75
Depth Cell Width (cm)	800	100

7.1.8.11.2.7 ROCSII Settings

Table 7.71 ROCSI Settings for A5M40

Min Depth	Max Depth	Clean	Number of samples	Litres	Time out
n/a	n/a	n/a	n/a	n/a	n/a

7.1.8.11.3 Mission Narrative

For this mission Autosub 5 would survey the “Coral Walls” Canyon and gather multibeam and sidescan data. Care must be taken to avoid the Mooring at the centre of the canyon. The plan was for Autosub 5 to start the mission east of the survey area. Autosub 5 would then dive and move to the north-west base of the canyon and survey back up the east wall. The AUV will then return down to the base and survey up the west side of the canyon. Existing multibeam show holes in the canyon wall so a mixture of altitude control and depth control must be used.

The mission ran successfully. An abort was triggered by Autosub 5 after it surfaced. The cause of the abort was a “battery under minimum threshold” health event.

7.1.8.11.4 Annotated Engineering Plots

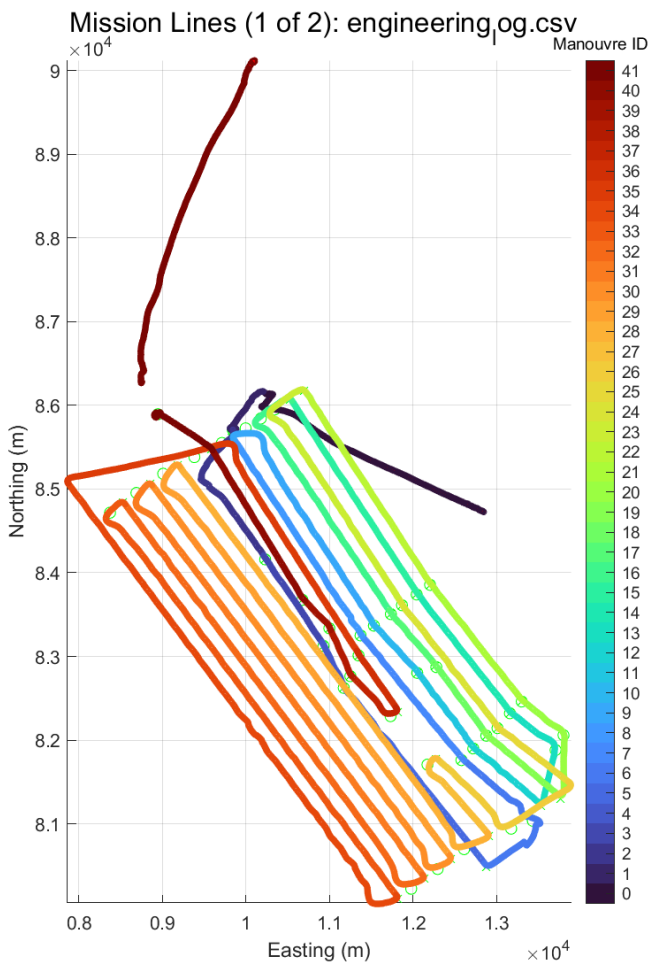

Fig. 7.69 A5M40 2D navigation coloured by time

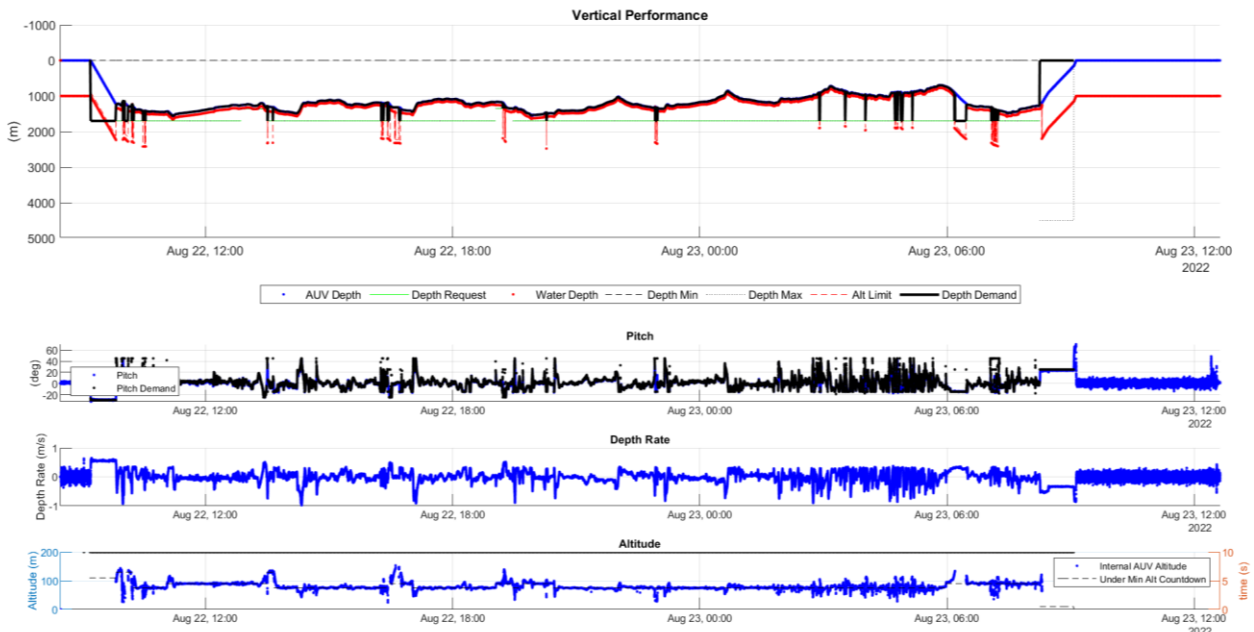

Fig. 7.70 A5M40 vertical performance plot

7.1.8.11.5 Mission Faults

Autosub triggered an abort after it had successfully completed the mission, due to the AUV's battery voltage dropping below the 10% percent threshold.

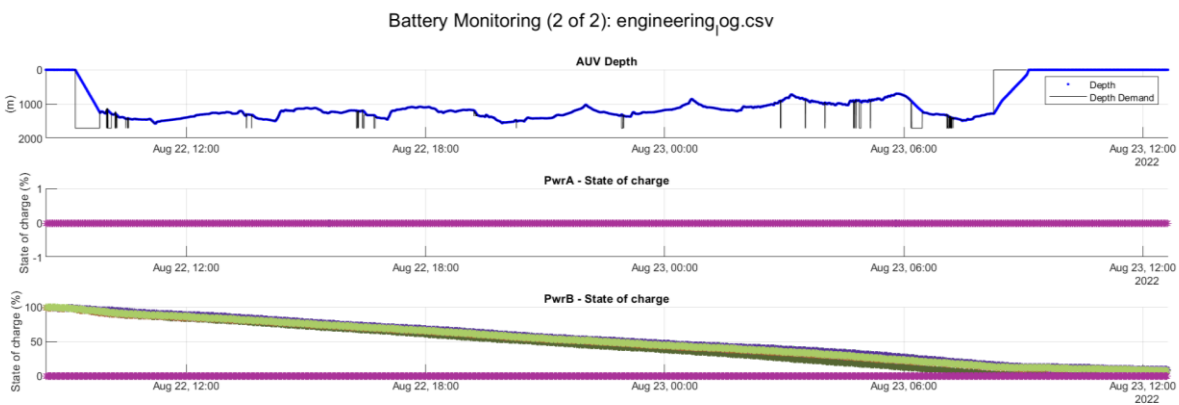

Fig. 7.71 A5M40 Battery monitoring

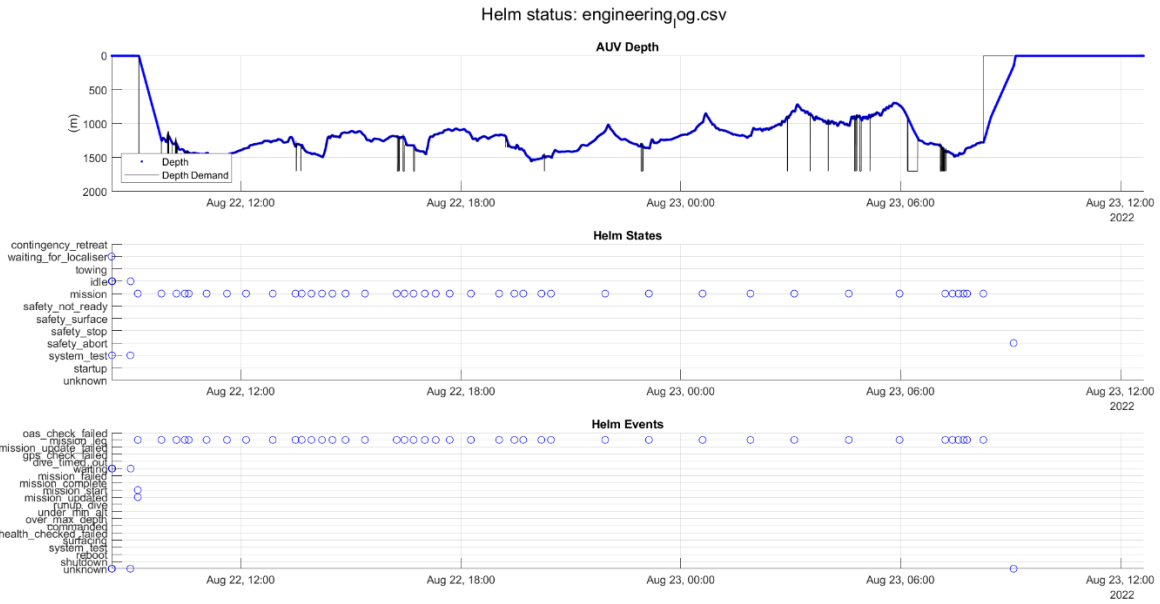

Fig. 7.72 A5M40 Helm status

7.1.8.11.6 Initial assessment of sensor data

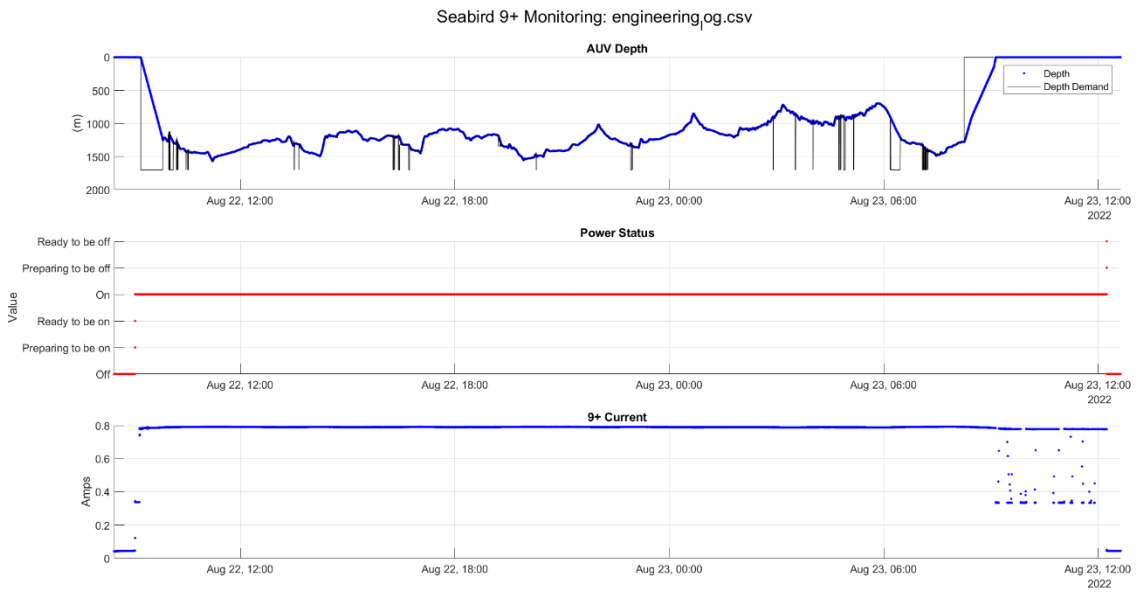

Fig. 7.73 A5M40 Seabird9+ diagnostic plots

Norbit Bathy Monitoring: engineering.og.csv

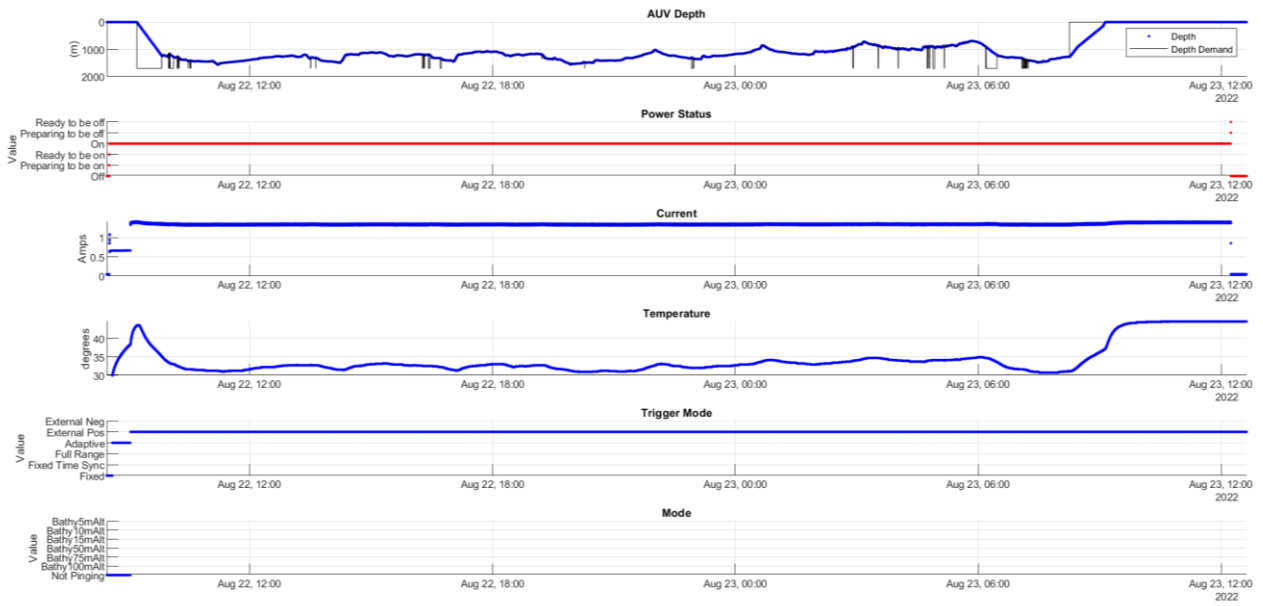

Fig. 7.74 A5M40 Norbit diagnostic plots

EdgeTech Sidescan: engineering.og.csv

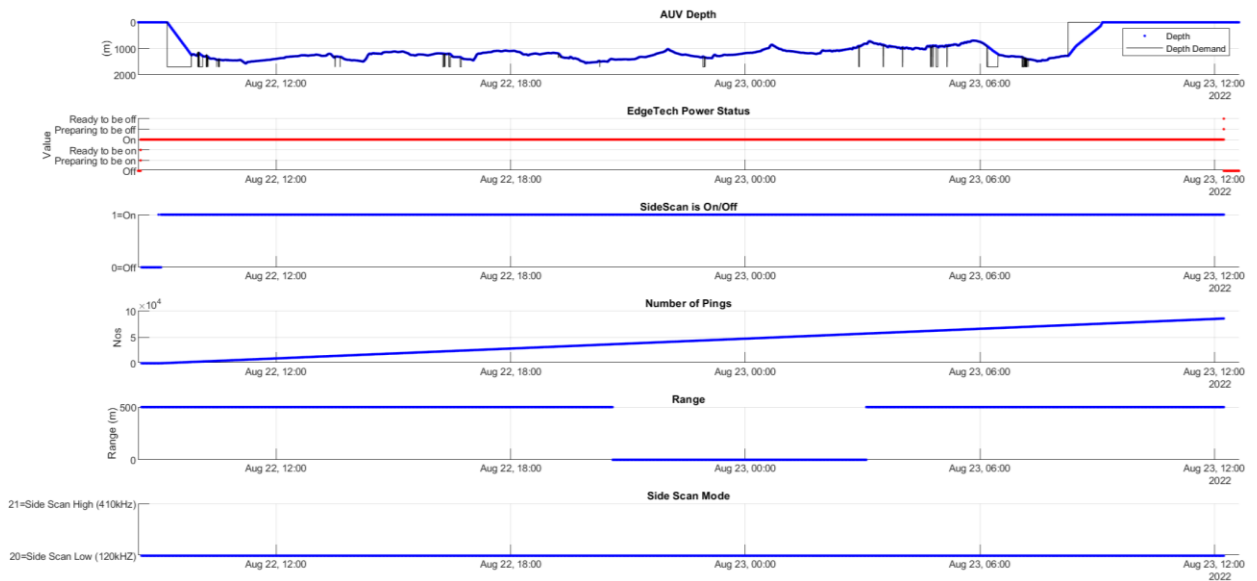

Fig. 7.75 A5M40 Edgetech diagnostic plots

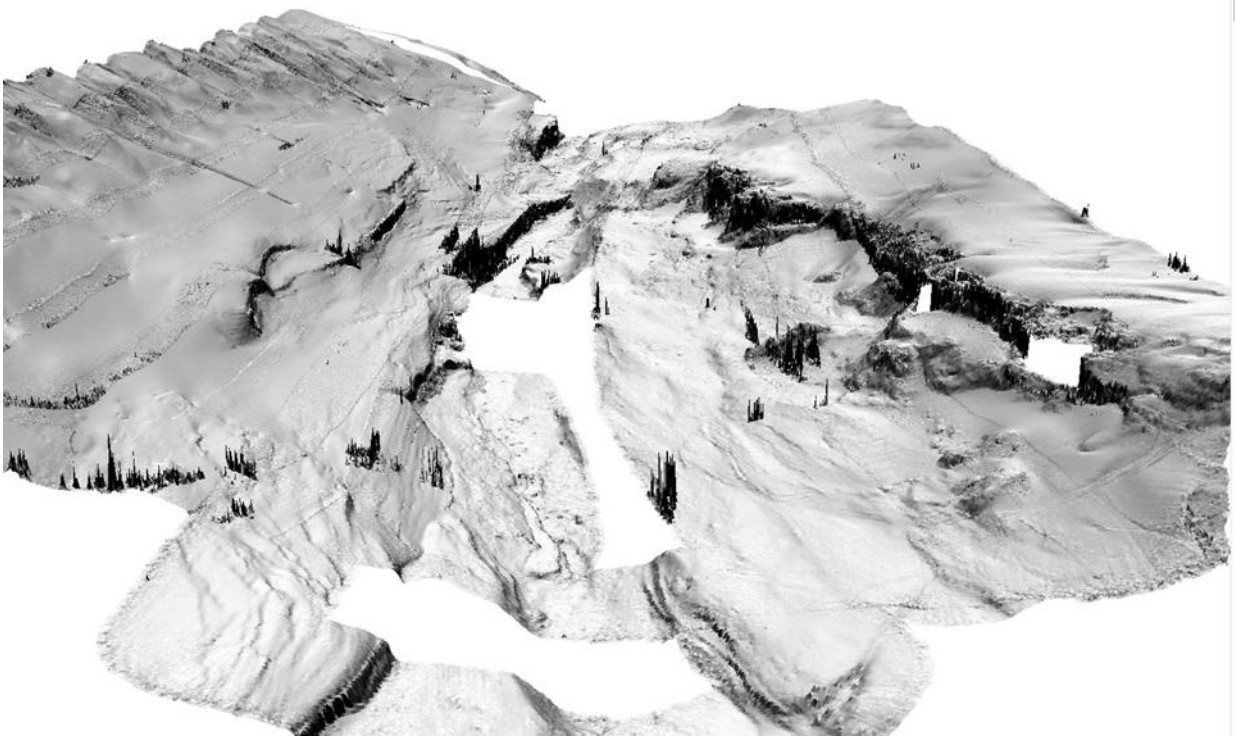

Fig. 7.76 3D rendering of coral wall MBES bathymetry collected during A5M40

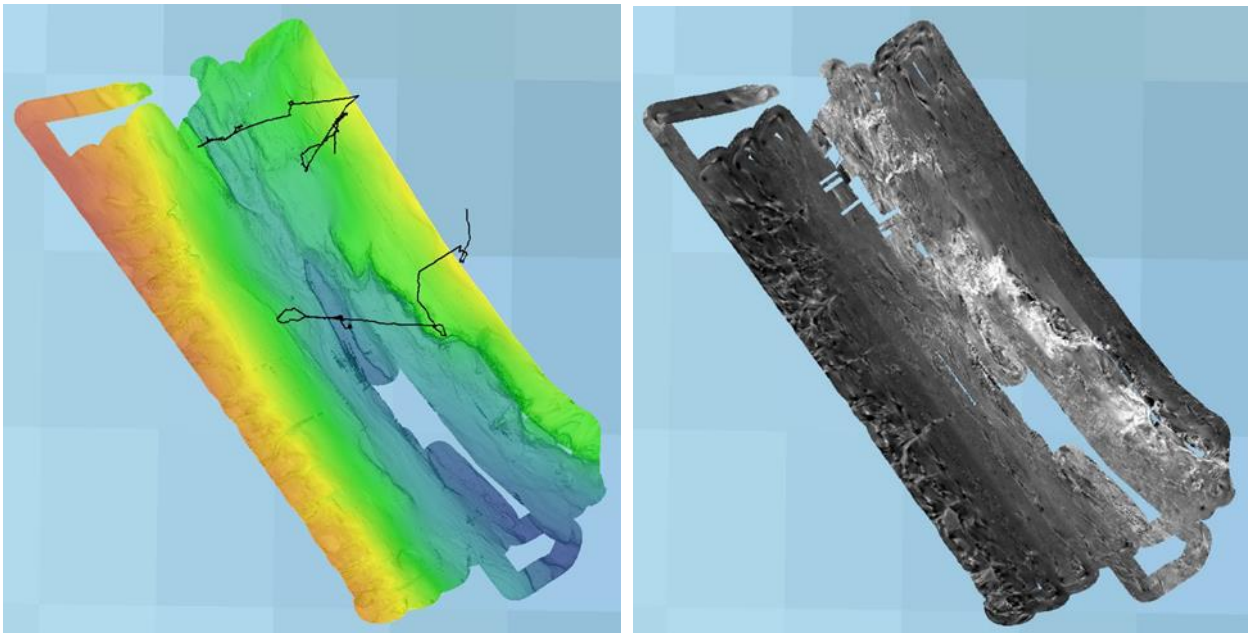

Fig. 7.77 Norbit MBES bathymetry (left) and backscatter (left) at the coral wall, collected during A5M40

7.1.8.12. Autosub5 M41 Mission Summary

7.1.8.12.1 Mission Statistics

Table 7.72 Details of mission A5M41

Mission Identifier	A5M41
Start Time	24-Aug-2022 13:40:11
Time Elapsed	3.3672 Hrs
Distance Travelled	8.9121 Km
Start Coordinates	48.4144 deg N, -9.6808 deg E
End Coordinates	48.3838 deg N, -9.7392 deg E
Max Depth	371.7369 meters
Minimum Altitude Recorded	0.18m
Start Battery Voltage / Start State of Charge	57.848V / 96%
End Battery Voltage / End State of Charge	57.15V / 86%

7.1.8.12.2 Mission Plan Description

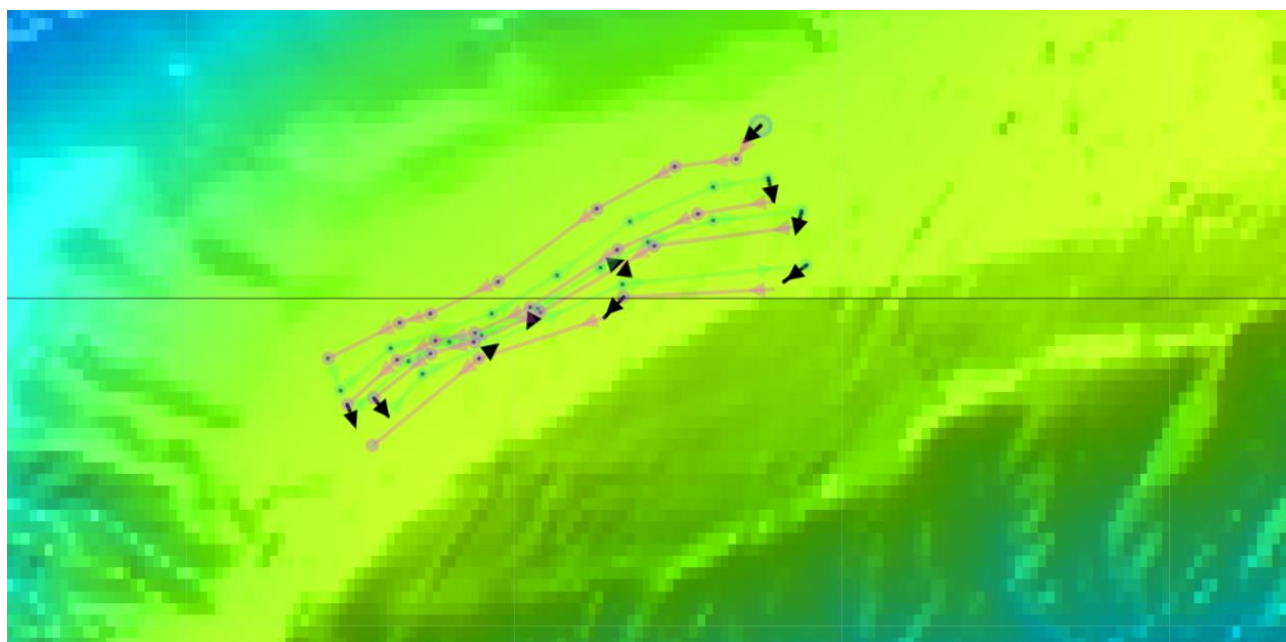

Fig. 7.78 C2 Mission Plan for mission A5M41

7.1.8.12.2.1 System Specs

Table 7.73 AUV system specs for A5M41

Wings	-3 degrees, middle position
Estimated Battery Use	33%

7.1.8.12.2.2 Navigation

Table 7.74 AUV Navigation settings for A5M41

Navigation Solution	Localiser
USBL Telemetry	Nice to have during the diving

7.1.8.12.2.3 OCS Critical Parameter Spec

Table 7.75 OCS parameter specifications for A5M41

Parameter	Value
No_contact_timer	12 hours
Safety_min_alt	1 m
Safety_max_depth	4500m
Iridium_period	5 mins

7.1.8.12.2.4 Trigger Configuration

Table 7.76 Trigger Configuration for A5M41

Autosub 5 Trigger Mode	
Norbit FLS Mode	Off

7.1.8.12.2.5 Payload Settings

Table 7.77 Payload settings for A5M41

Device	Required (Y/N)	Mode
9+ CTD	Yes inc DO	N/A
AESA Camera	Yes	N/A
Norbit Bathy	Yes	
Edgetech 2205	Yes	
Wetlabs BBRT	Yes	N/A
NOC ROCSI	Yes	
Applied Physics Magnetometer	No	N/A

7.1.8.12.2.6 ADCP/DVL Settings

Table 7.78 ADCP/DVL Settings for A5M41

Setting	ALR Default Value	Requested Values
Water Track Start range(m)	8.5	8.5
Water Track bin width(m)	96	96
Number of Bins	12	12
Depth Cell Width (cm)	800	800

7.1.8.12.2.7 ROCSI Settings

Table 7.79 ROCSI Settings for A5M41

Min Depth	Max Depth	Clean	Number of samples	Litres	Time out
300	400	1	24	2	2400

7.1.8.12.3 Mission Narrative

The sub aborted due to an under-min altitude condition triggered because of a slop of @10 degrees in the terrain which the sub could not cope with. The depth demand with respect to the AUV depth was too small and increasing to slow to create a sensible pitch demand that could have brought the sub in a safe position.

7.1.8.12.4 Annotated Engineering Plots

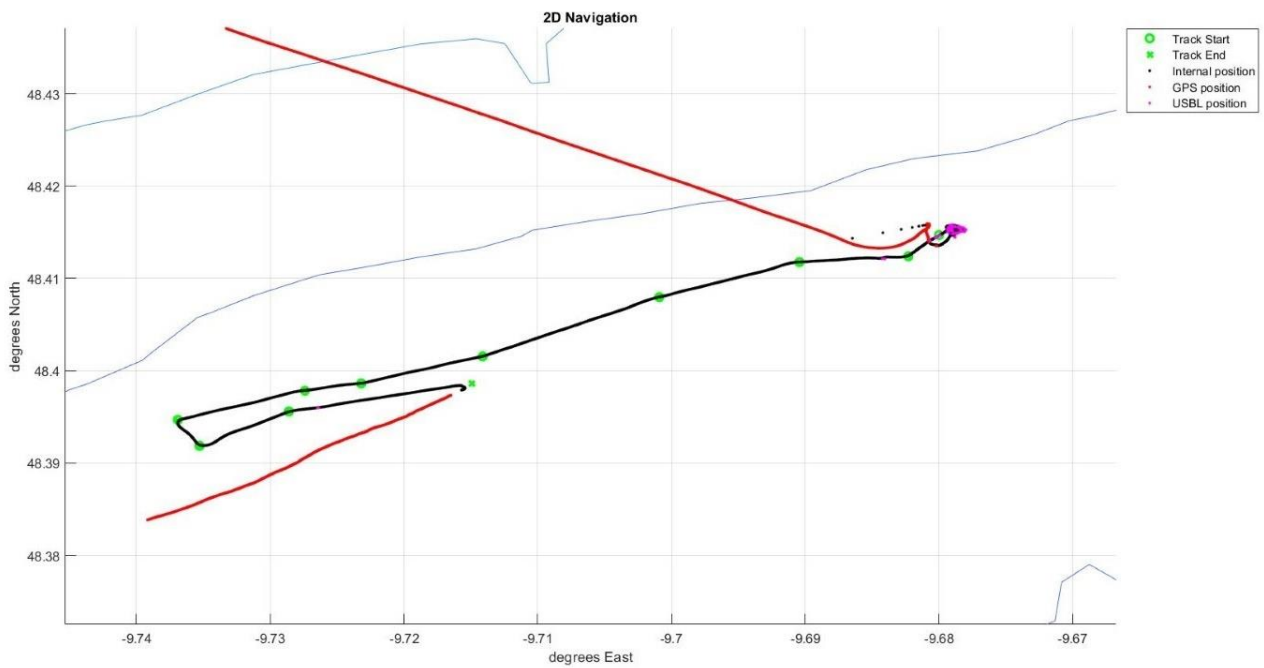

Fig. 7.79 2D Navigation plot for mission A5M41

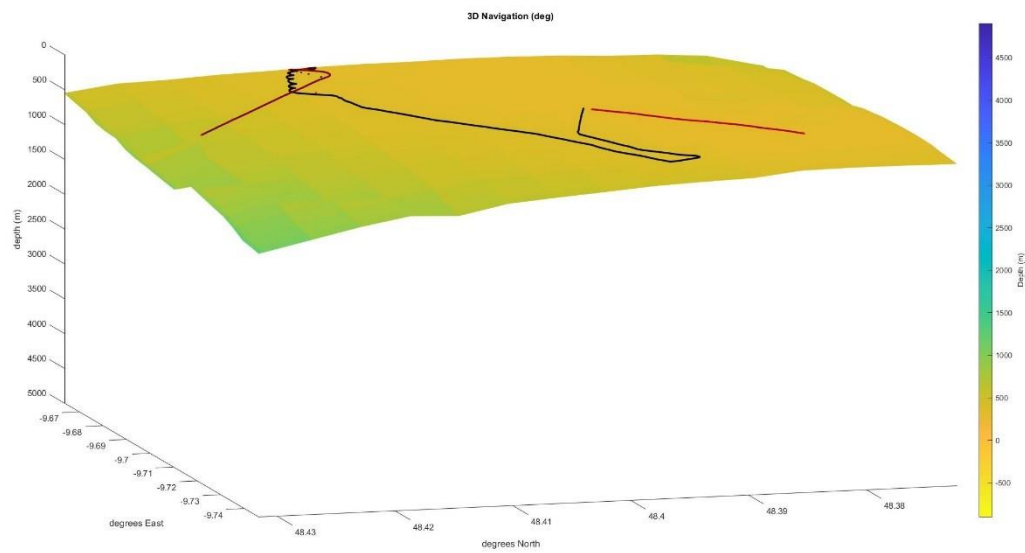

Fig. 7.80 3D navigation plot for mission A5M41

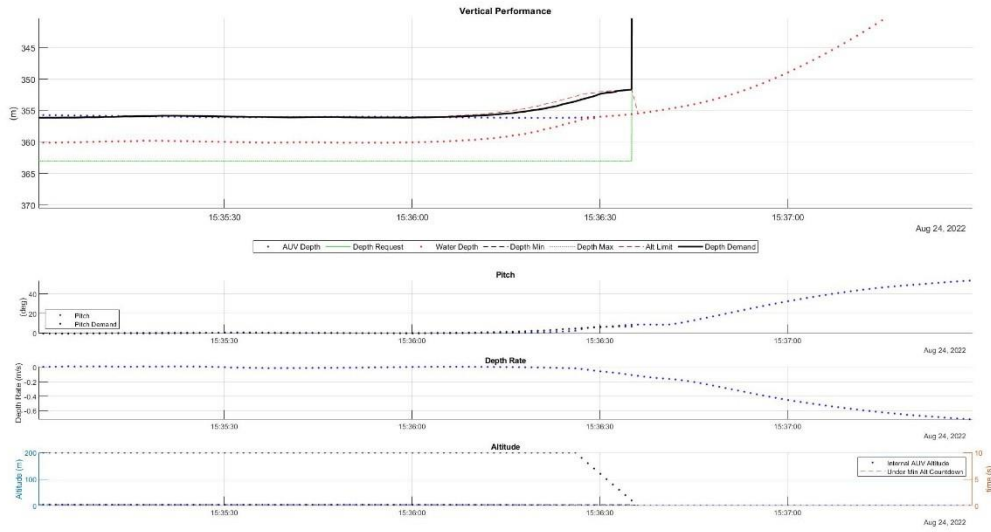

Fig. 7.81 Vertical performance plot for mission A5M41 illustrating the under min alt event

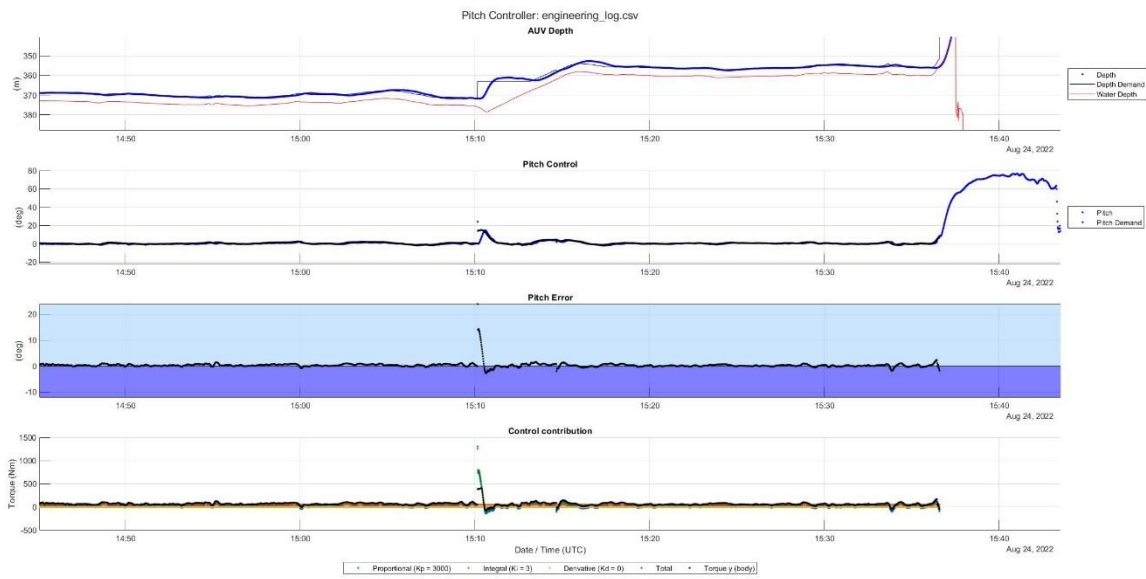

Fig. 7.82 Pitch behaviour plot of mission A5M41 at the time of the under min alt event

7.1.8.12.5 Mission Faults

Under-min altitude triggered and led the sub into an abort. Roll performance degradation with a steady state error of ~ 2 degrees

7.1.8.12.6 Initial Assessment of Sensor Data

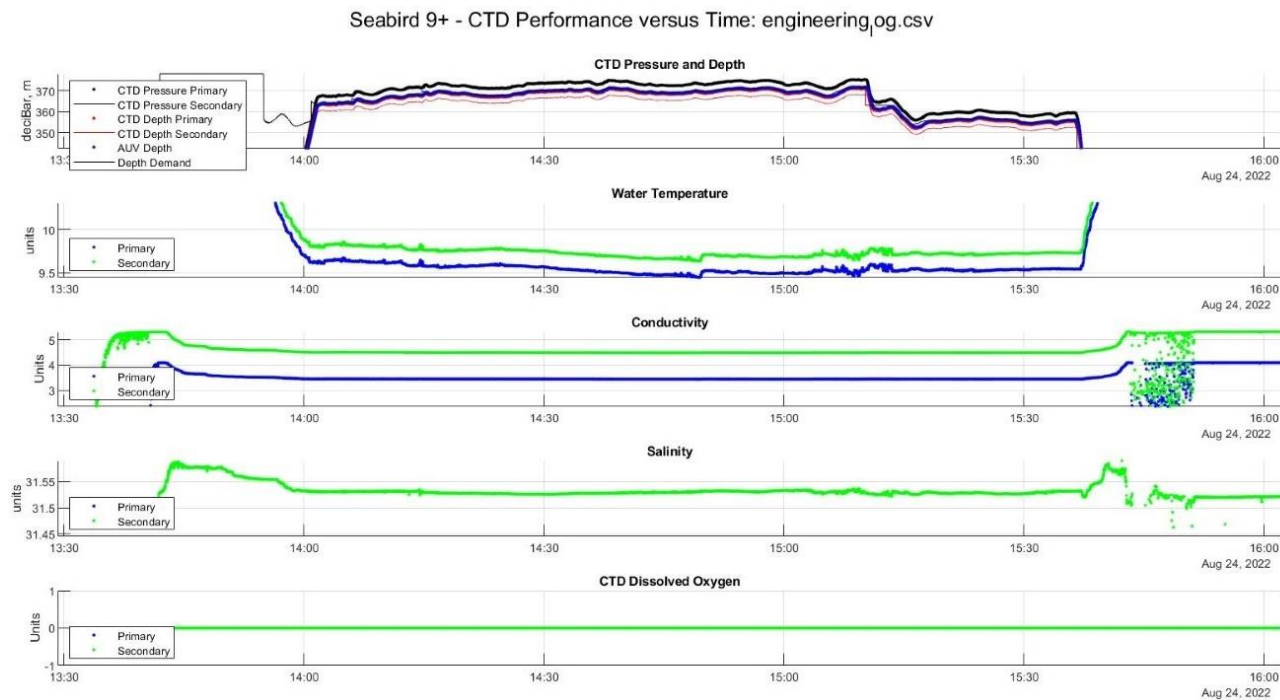

Fig. 7.83 Seabird 9+ statistics plot for mission A5M41

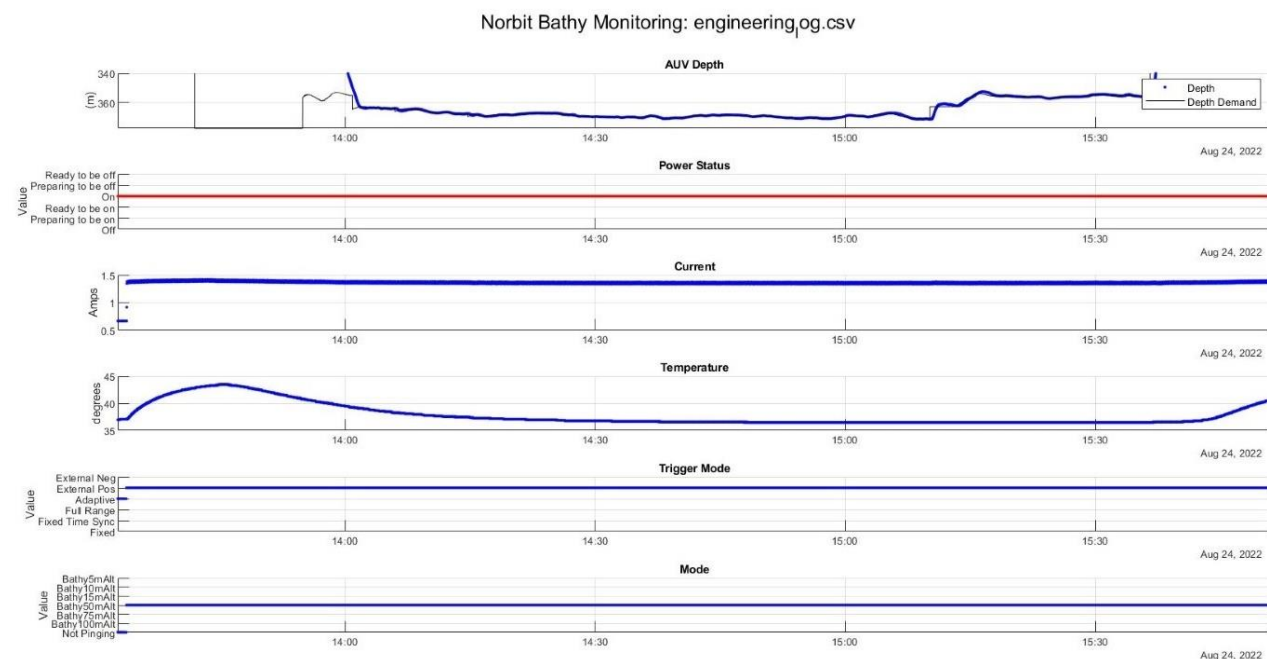

Fig. 7.84 Norbit diagnostics plot for mission A5M41

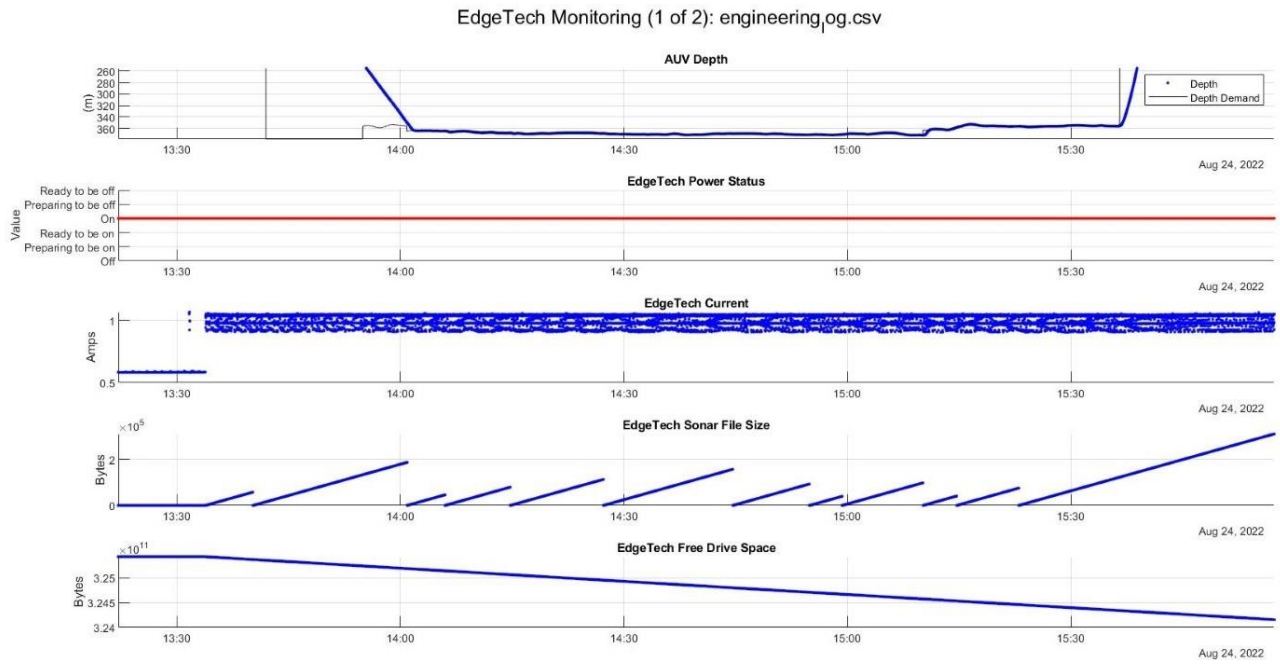

Fig. 7.85 Edgetech diagnostics plot for mission A5M41

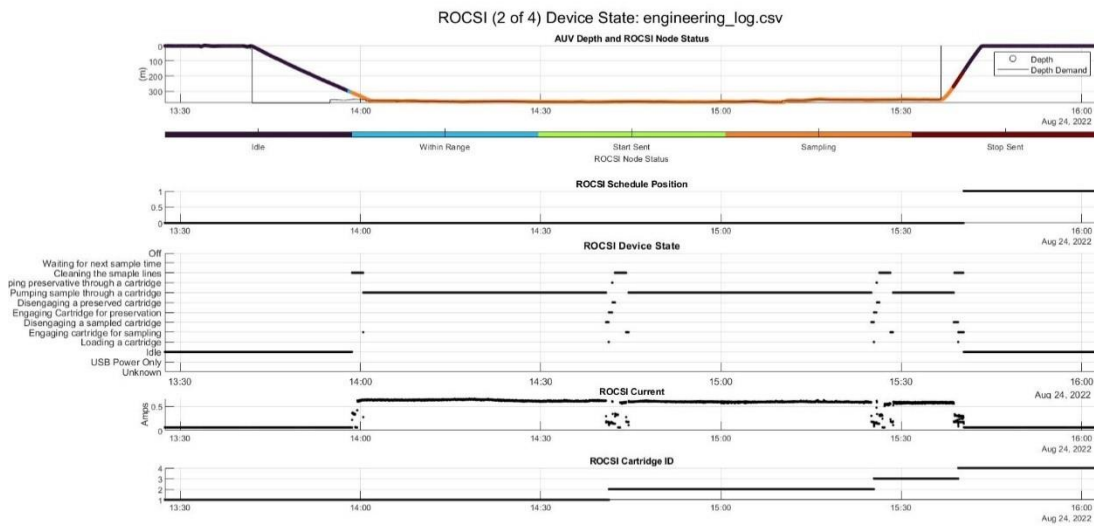

Fig. 7.86 ROCSI diagnostics plot for mission A5M41

7.1.8.13. Autosub5 M42 Mission Summary

7.1.8.13.1 Mission Statistics

Table 7.80 Details of mission A5M42

Total Mission Duration	22:15
Distance Travelled (km)	<87.33km
Maximum Depth (m)	4904
Minimum Altitude (m)	2.1
Battery Voltage end of mission	48.92

7.1.8.13.2 Mission Plan Description

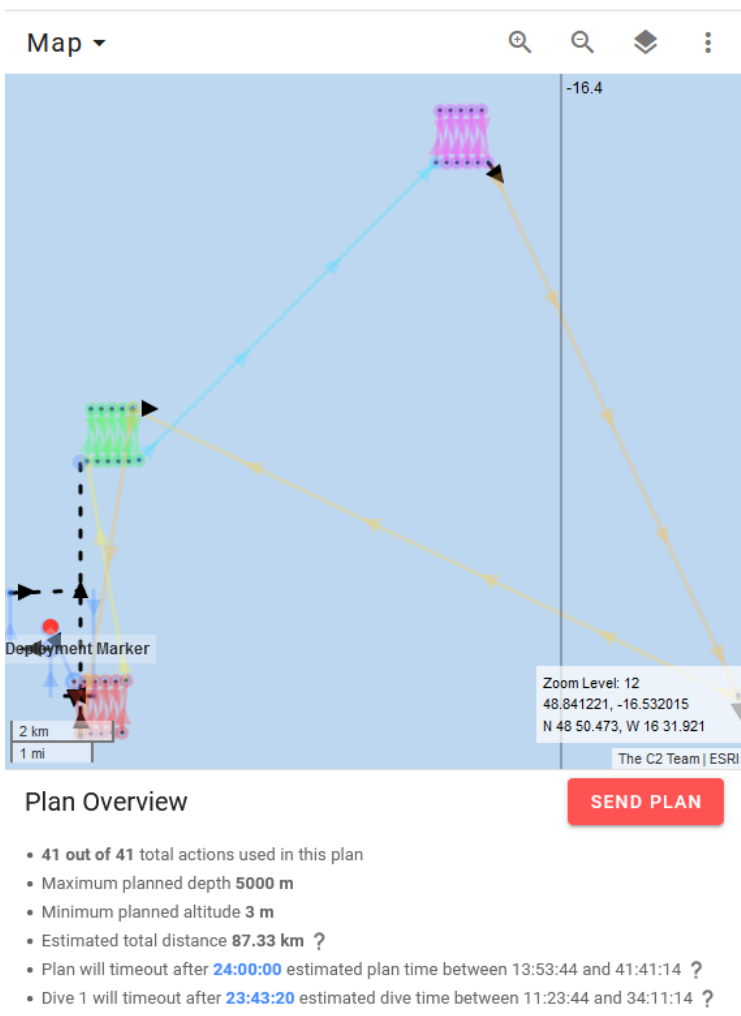

Fig. 7.87 Screenshot of planning module layout for A5M42

7.1.8.13.2.1 System Spec

Table 7.81 AUV system specs for A5M42

Wings	-3 degrees, middle position
Estimated Battery Use	33%

7.1.8.13.2.2 Navigation

Table 7.82 AUV Navigation settings for A5M42

Navigation Solution	Localiser
USBL Telemetry	Nice to have during the diving

7.1.8.13.2.3 OCS Critical Parameters Spec

Table 7.83 OCS parameter specifications for A5M42

Parameter	Value
No_contact_timer	24 hours
Safety_min_alt	1 m
Safety_max_depth	6000m
Iridium_period	5 mins

7.1.8.13.2.4 Trigger Configuration

Table 7.84 Trigger Configuration for A5M42

Autosub 5 Trigger Mode	Autosub5_15m_sidescan_5ms
Norbit FLS Mode	Off

7.1.8.13.2.5 Payload Settings

Table 7.85 Payload settings for A5M42

Device	Required (Y/N)	Mode
9+ CTD	Yes inc DO	N/A
AESA Camera	Yes	1Hz
Norbit Bathy	No	N/A
Edgetech 2205	Yes	High Freq 410, 5ms gain10
Wetlabs BBRT	Yes	N/A
NOC ROCSI	Yes	/home/ocs/m42rocsii.csv
Applied Physics Magnetometer	No	N/A

7.1.8.13.2.6 ADCP/DVL Settings

Table 7.86 ADCP/DVL Settings for A5M42

Setting	ALR Default Value	Requested Values
Water Track Start range(m)	8.5	1
Water Track bin width(m)	96	37.5
Number of Bins	12	75
Depth Cell Width (cm)	800	100

7.1.8.13.2.7 ROCSII Settings

Table 7.87 ROCSI Settings for A5M42

Min Depth	Max Depth	Clean	Number of samples	Litres	Time out
4800	4900	1	1	2	2400

7.1.8.13.3 Mission Narrative

Relatively good conditions, long and lazy swell. AS5 deployed without fuss (15:42)

Straight line dive strategy with target depth at waypoints, RRS James Cook tracked behind to assist NAV data with Telemetry. Tracked more or less all the way to target depth of 4840m, with Telemetry. Approx 2.5 hours to 4800m.

It was all fairly tame (no abnormalities observed in engineering plots). Ship was released (18:30, move to ROV dive station) AS5 had established bottom lock, and pilots checked in periodically for any iridium messages throughout the night. Over 80,000 images recorded (although negating dive and surface, about 80% are useable)

Arrived at recovery area (13:00) the following day, and slowly tracked over the mission area looking for AS5. Message received (13:34) demonstrating surfacing from 1400m. AS5 surfaced at approximately 14:21 on a still loiter. At 14:51, a dead node was reported causing an abort. This was related to an undiagnosed failure in the forward power tube pending further investigation back at base.

On recovery, the aft line boss hook got caught in the LARS winch drum which wasn't immediately obvious. Exercising the winch to try and free the boss hook actually caused the boss hook to snap. The aft line was completely lost and the ABs successfully attempted to grapple the lost line. A spare boss hook was coupled, and the recovery continued safely.

On deck, the e-stop was pulled over power concerns, and the forward payload tube was investigated – completely shorted.

7.1.8.13.4 Annotated Engineering Plots

7.1.8.13.4.1 2D/3D Navigation

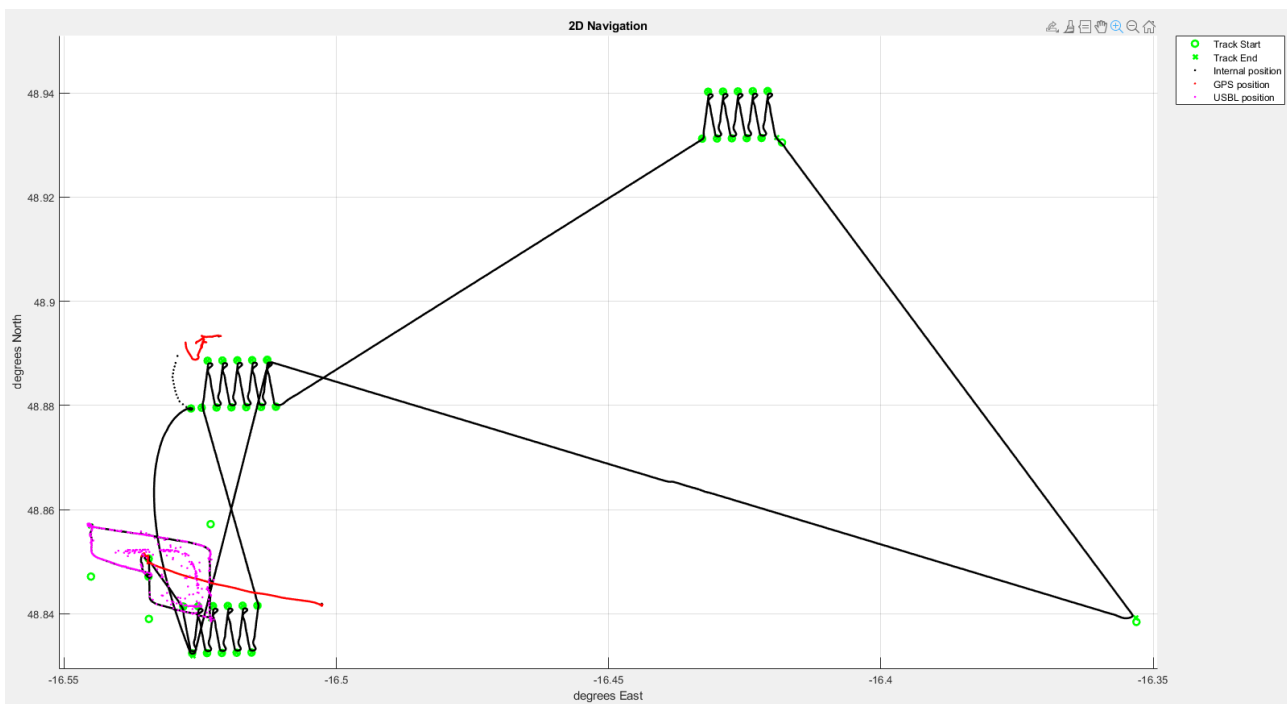

Fig. 7.88 2D navigation plot for mission A5M42

Good USBL Telemetry was passed to the AvTrak throughout the dive. False location was likely due to shallow depths earlier in the mission, during turns etc. Overshoot in track turns high in some cases. Perhaps an easterly current existed

7.1.8.13.4.2 Vertical Performance

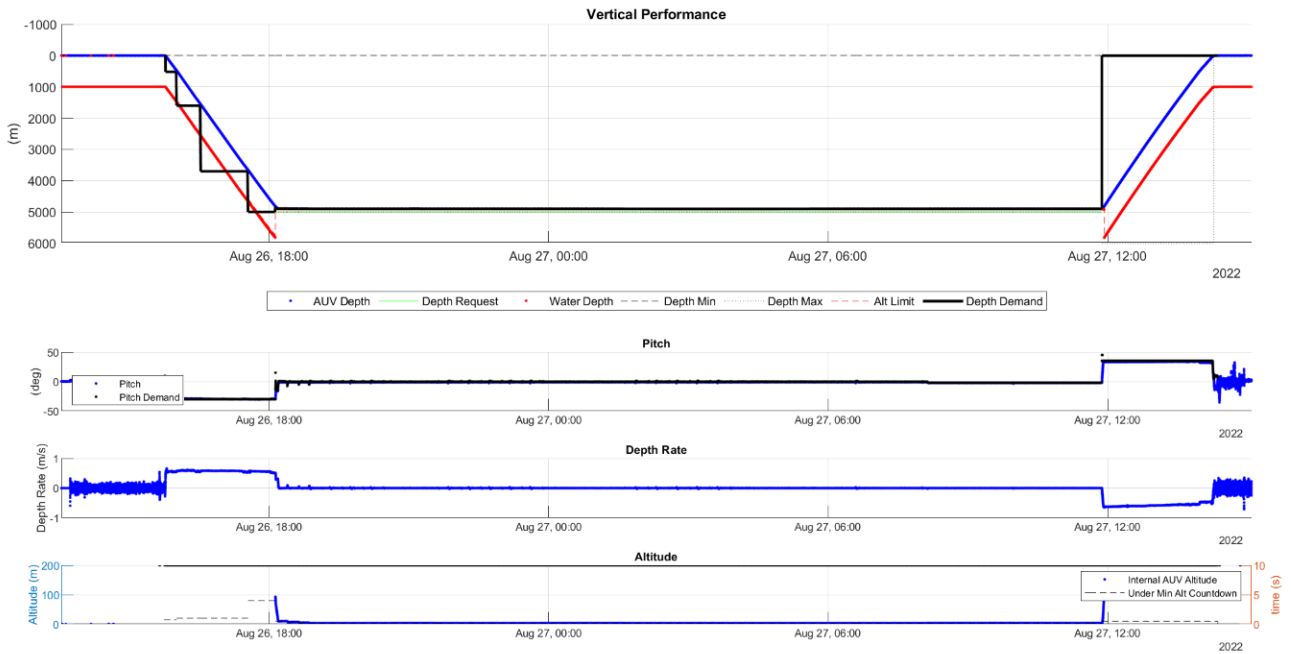

Fig. 7.89 Vertical performance (top) and pitch performance plots for mission A5M42

The track dive strategy worked well, negating the spiral dive behaviour that is known to overload the outboard thruster.

7.1.8.13.4.3 AESA Camera

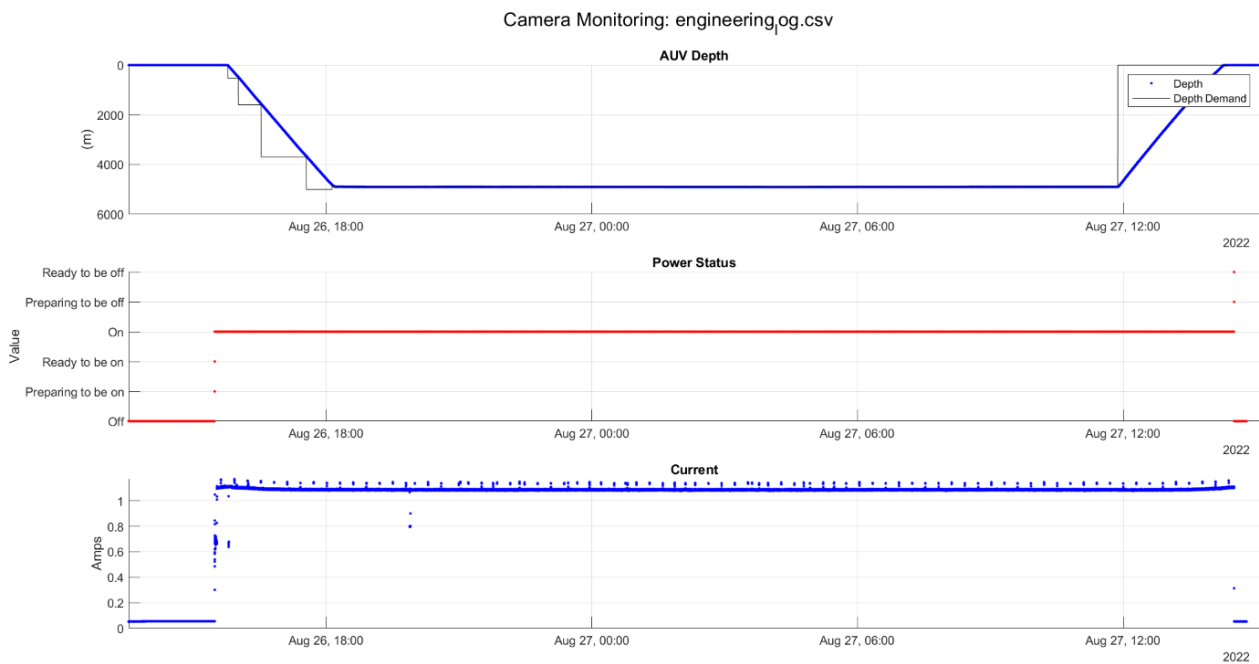
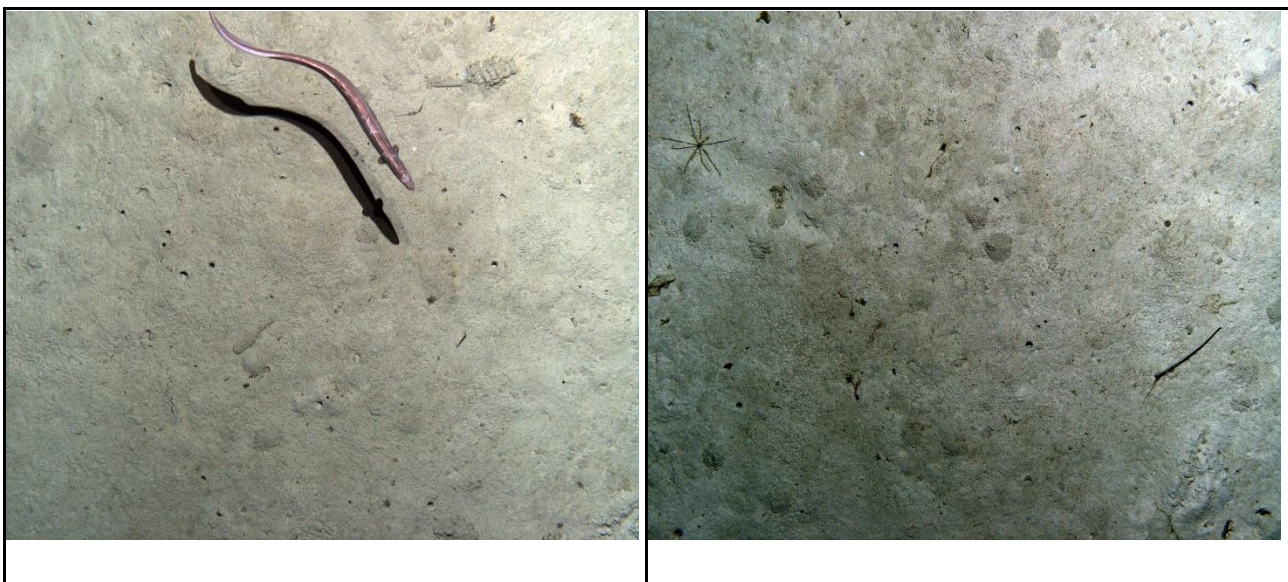
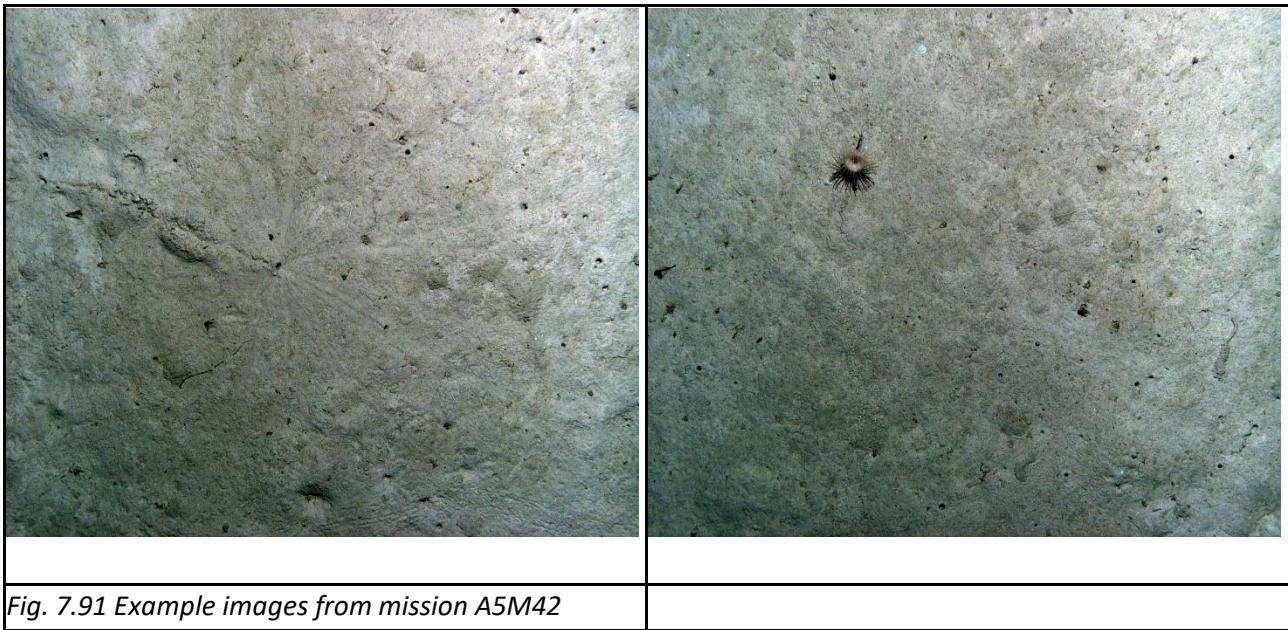

Fig. 7.90 Camera diagnostic plots for mission A5M42

- Vertical Images Recorded: 80,000
- Estimate of Useful Vertical Images: 64,000
- Forward Images Recorded: 0
- Estimate of Useful Forward Images: 0





7.1.8.13.4.4 NOC ROCSI

Due to operational concerns at survey depth, only one sample was loaded and pre-engaged

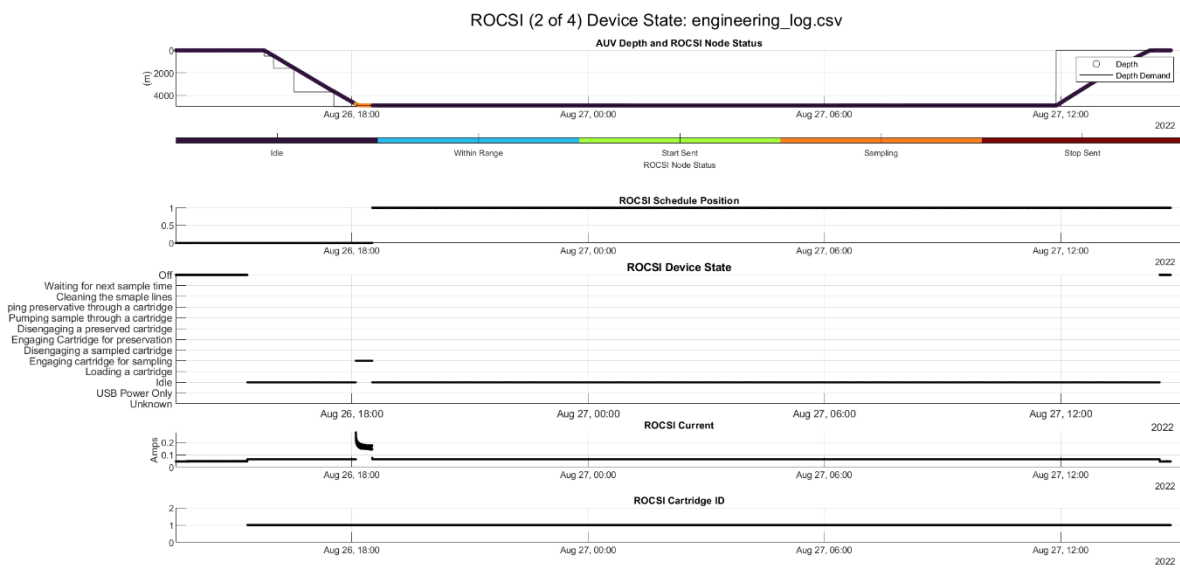

Fig. 7.92 ROCSI diagnostic plots for mission A5M42

7.1.8.14. Autosub5 M43 Mission Summary

7.1.8.14.1 Mission Statistics

Table 7.88 Details of mission A5M43

Mission Identifier	A5M43
Start Time	28-Aug-2022 16:03
End Time (Recovered on deck)	29-Aug-2022 16:30
Total Mission Duration	21:07
Distance Travelled (km)	<95.51km
Start Coordinates	48.6943598deg N, --16.4034876deg E
End Coordinates	48.6761deg N, --16.40282 deg E
Maximum Depth (m)	4894
Minimum Altitude (m)	2.5
Battery Voltage end of mission	48.28

7.1.8.14.2 Mission Plan Description

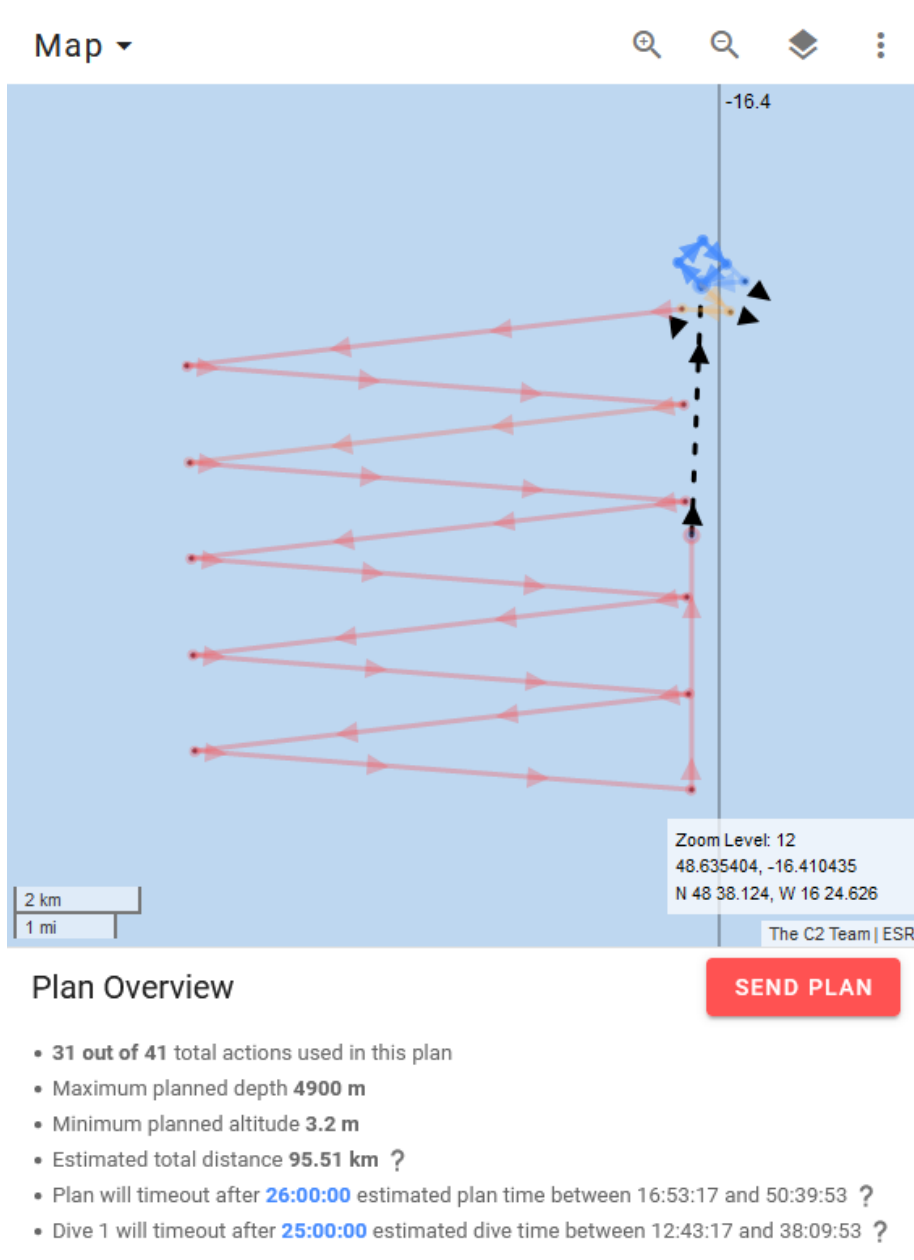

Fig. 7.93 Screenshot of planning module layout for A5M43

7.1.8.14.2.1 Vehicle Configuration

- Wings -3 degrees – 1degree on boths wings = 5N of downforce. 6Degrees = 30N
- 120 N Positive Buoyancy – should be greater than 100N
- 85 Nm/rad Stiff – Should be greater than 75Nm
- Battery String 1: No of Packs 12
- Battery String 2: No of Packs 8

- Battery String 3: No of Packs -
- Battery String 4: No of Packs -

- Primary Navigation: *Localiser*
- USBL: *Telemetry throughout dive to ~3800m, tracking while ship available*

7.1.8.14.2.2 Sensor Configuration

Table 7.89 Sensor configuration for mission A5M43

	On/Off	Mode	Other Info
9+ CTD	Yes inc. DO	N/A	
AESA Camera	Yes	1 Hz	
Norbit Bathy	No		
Norbit OAS	No		
Edgetech 2205	Yes	HF 410, 5ms, Gain=10	
Trigger Mode	N/A	Autosub5_3m_Camera_5ms	
Wetlabs BBRT	Yes	N/A	
NOC ROCSI	Yes	M43rocsi.csv	
Applied Physics Magnetometer	No	N/A	Unplugged

7.1.8.14.3 Mission Narrative

Relatively good conditions. AS5 was sent out on LARS for start-up test (15:29), but it was recognised that forward payload tube wasn't subscribing to ROS topics (15:37). AS5 was returned to deck with cooling enabled to prevent overheat. The error was cleared, and AS5 deployed (15:52), mission sent (16:03)

RRS James Cook sat in the middle of the planned box dive to assist NAV with Telemetry. Generally good comms from Deep Marker 6, good telemetry to AvTrak, but fell over at ~3000m, self-resetting at (17:41) and more reliable thereafter.

It was all pretty uneventful (no abnormalities observed in engineering plots) once the ship was released (18:30, move to ROV dive station) AS5 had established bottom lock, with periodic checks for any iridium messages throughout the night. Over 80,000 images recorded (although negating dive and surface, about 80% are useable)

Arrived at recovery point (12:00) the following day, and slowly back tracked over the mission area looking for AS5. Message received from Deep Marker 6 (13:46) demonstrating turn for last mission leg. This leg was a bonus (not required by science) and with an estimated ~3.5 hours to surface time, the decision was made to acoustically abort AS5 (14:07). The AvTrak, despite regular pings didn't seem to be getting the abort command. (Possible RAW and SMS setting in PAN port misconfiguration?). Many attempts were made until at (15:10, 3800m) the message got through.

On abort, AS5 achieved a ~2.0m/s surge at a pitch angle of 75 degrees. AS5 surfaced at 16:05, and was on deck at 16:30 without any particular excitement.

7.1.8.14.4 Annotated Engineering Plots

7.1.8.14.4.1 2D/3D Navigation

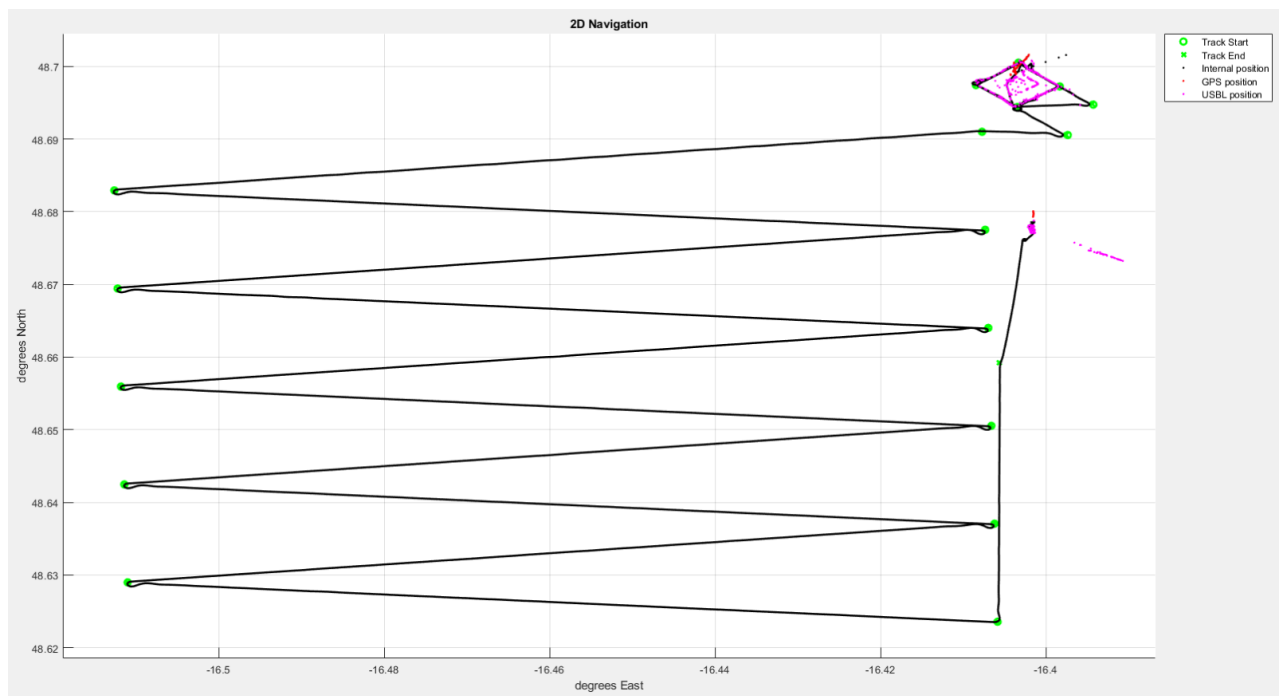

Fig. 7.94 2D navigation plot for mission A5M43

Good USBL Telemetry was passed to the AvTrak throughout the dive. False location was likely due to shallow depths earlier in the mission, during turns etc. Some overshoot exhibited in track turns.

AS5 was tracking back to the launch point, and several acoustic abort commands had gone unheard. Eventually the abort got through and AS5 went into an upward spiral.

7.1.8.14.4.2 Vertical Performance

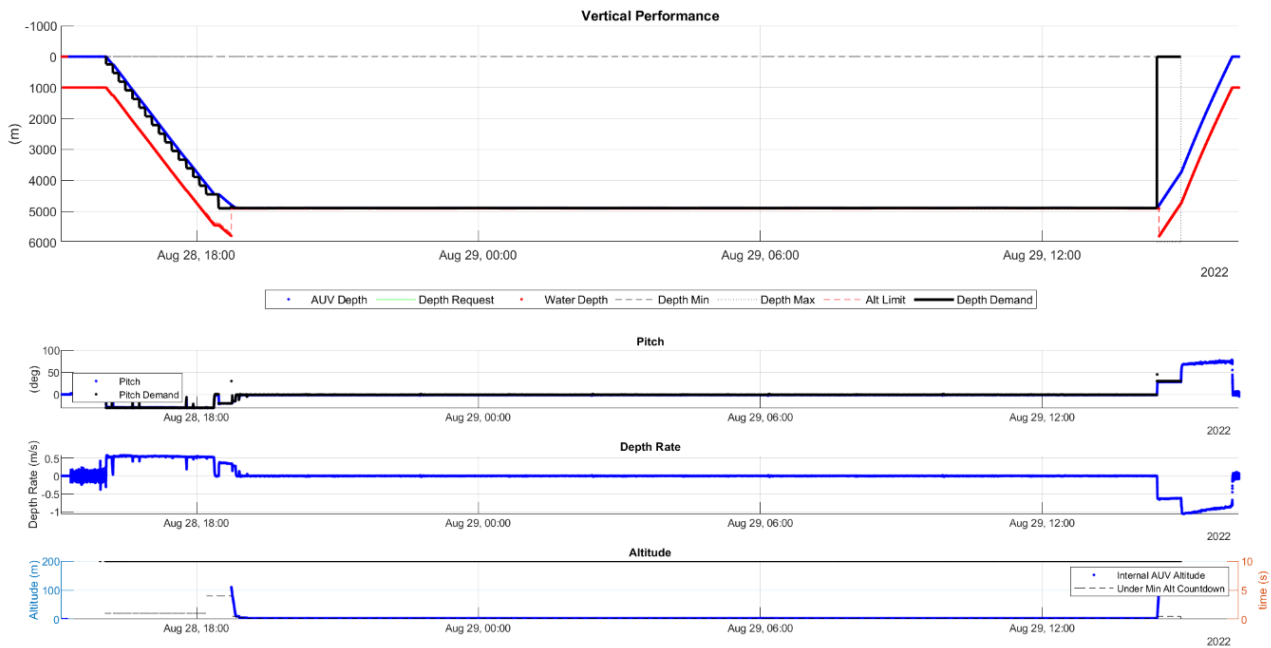

Fig. 7.95 Vertical performance (top) and pitch diagnostics (bottom) plots for mission A5M43

The staircase box dive strategy worked well, negating the spiral dive behaviour that is known to overload the outboard thruster. A very flat survey, followed by a speedy ascent.

7.1.8.14.5 Mission Faults

During overboard testing, it was identified that the forward payload tube wasn't subscribed to ROS topics. AS5 was briefly returned to deck whilst the error was fixed. The AvTrak dropped out during the dive, but recovered after a 34-minute self-reset. NOCSUB2KUI-565 Other than that, the mission ran well to its full course. We were unable to abort AS5 at full depth. It is not fully understood if this was a range or config. Issue

7.1.8.14.6 Mission Examples



Fig. 7.96 Example photographs from mission A5M43

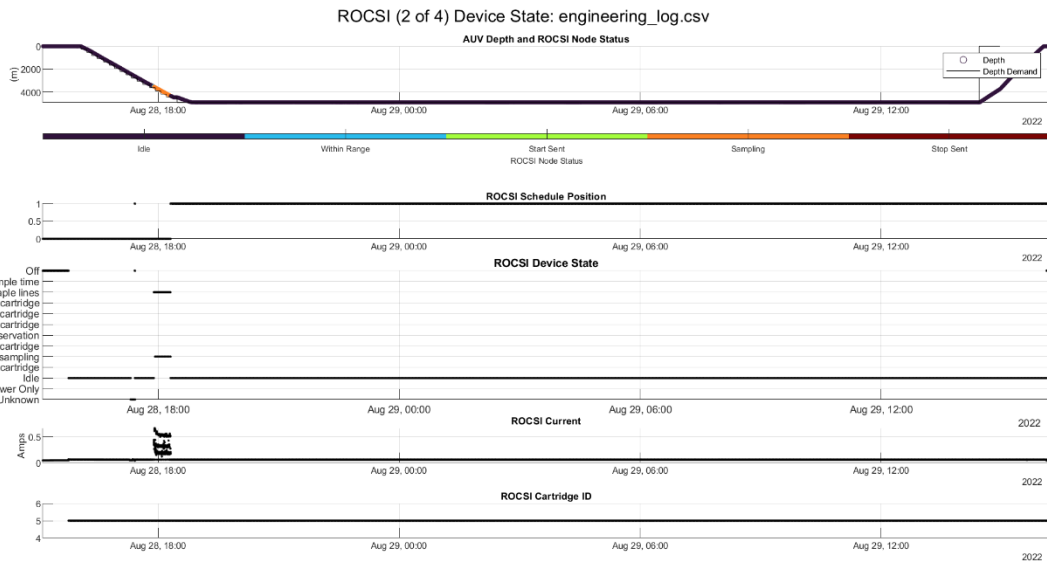

Fig. 7.97 ROCSI performance during mission A5M43

7.1.8.15. Autosub5 M44 Mission Summary

7.1.8.15.1 Mission Statistics

Table 7.90 Details of mission A5M44

Mission Identifier	AS5M044
Start Time	31-Aug-2022 15:22:26
Time Elapsed	21.6217 Hrs
Distance Travelled	84.0748 Km
Start Coordinates	48.5665 deg N, -9.7593 deg E
End Coordinates	48.5544 deg N, -9.7772 deg E
Max Depth	208.5235meters
Minimum Altitude Recorded	2.95m
Start Battery Voltage / Start State of Charge	57.952V / 96.5%
End Battery Voltage / End State of Charge	49.590V / 14.5%

7.1.8.15.2 Mission Plan Description

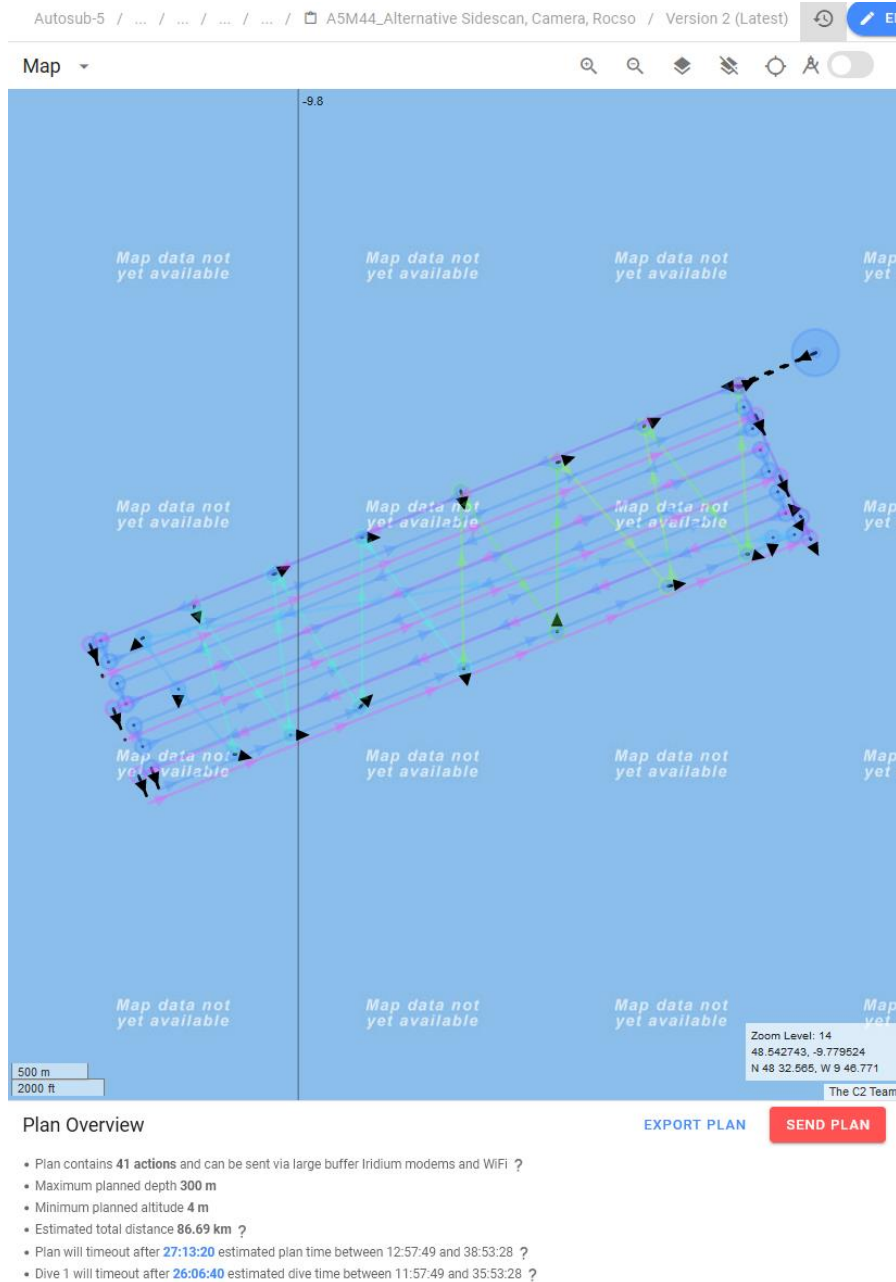

Fig. 7.98 Screenshot of planning module layout for A5M44

7.1.8.15.2.1 System Spec

Table 7.91 AUV system specs for A5M44

Wings	-3 degrees, middle position
Estimated Battery Use	25 KWh

7.1.8.15.2.2 Navigation

Table 7.92 OCS parameter specifications for A5M44

Navigation Solution	Localiser
USBL Telemetry	Required

7.1.8.15.2.3 OCS Critical Parameters Spec

Table 7.93 OCS parameter specifications for A5M44

Parameter	Value
No_contact_timer	24 hours
Safety_min_alt	1m
Safety_max_depth	4500m
Iridium_period	5 mins
Flight_style_depth_params	Kd:0.02, Ki:0.002, Kp:0027, anti_wind_up 0.06-0.02
Cross track correction	true

7.1.8.15.2.4 Trigger Configuration

Table 7.94 Trigger Configuration for A5M44

Autosub 5 Trigger Mode	Autosub5_15m_SS_Main_SBP16ms
Norbit FLS Mode	N/A

7.1.8.15.2.5 Payload Settings

Table 7.95 Payload settings for A5M44

Device	Required (Y/N)	Mode
9+ CTD	Yes inc DO	N/A
AESA Camera	Yes	1Hz
Norbit Bathy	Yes	400khz 75_DIR0 140
Edgetech 2205	Yes	High frequency 16ms 2-13khz sweep
Wetlabs BBRT	Yes	N/A
NOC ROCSI	yes	/home/ocs/m44rocsi.csv
Applied Physics Magnetometer	Yes	N/A

7.1.8.15.2.6 ADCP/DVL Settings

Table 7.96 ADCP/DVL settings for A5M44

Setting	ALR Default Value	Requested Values
Water Track Start range(m)	8.5	1
Water Track bin width(m)	96	37.5
Number of Bins	12	75
Depth Cell Width (cm)	800	100

7.1.8.15.2.7 ROCSI Settings

Table 7.97 ROCSI Settings for A5M44

Min Depth	Max Depth	Clean	Number of samples	Litres	Time out
90	157	1	1	2	2400
90	157	1	1	2	2400
90	157	1	1	2	2400
90	157	1	1	2	2400
90	157	1	1	2	2400
0	70	1	1	2	2400
150	400	1	7	2	2400
0	130	1	1	2	2400
0	400	1	10	2	2400

7.1.8.15.3 Mission Narrative

This mission took place in a new area at the top to the canyons. This survey consists of a 75m 400kHz multibeam, a 15m 410kHz (High Frequency) side scan and a 4 m camera survey. During the 15m and 4m altitude runs, the ROCSI system was also running and collected 21 sample.

Due to the steep terrain and the limitations which the ROCSI sampler could managed by the AUV. This mission was planned in creative way to properly spread out the number of ROCSI samples over the survey area. After the AUV would finish a leg of the survey, the AUV would radically change its depth and fly high above the survey. This change in depth start a new round of sampling from the ROCSI. This approach allowed us to ensure that 10 samples were not taken until the AUV started its camera survey.

Due to a cable failure on the camera trigger line meant flashes did not operate. This meant that is mission recorded no useful images to pair with the ROCSI e-DNA dataset

7.1.8.15.4 Annotated Engineering Plots

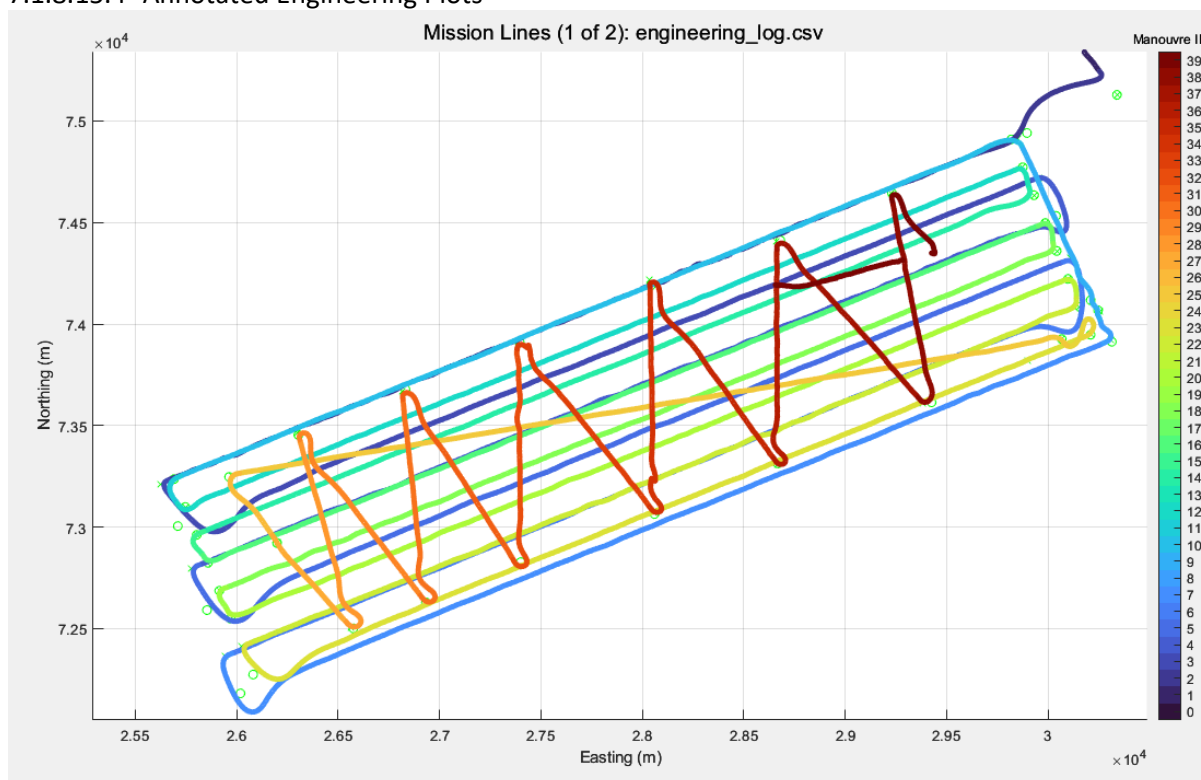

Fig. 7.99 2D navigation of mission A5M44

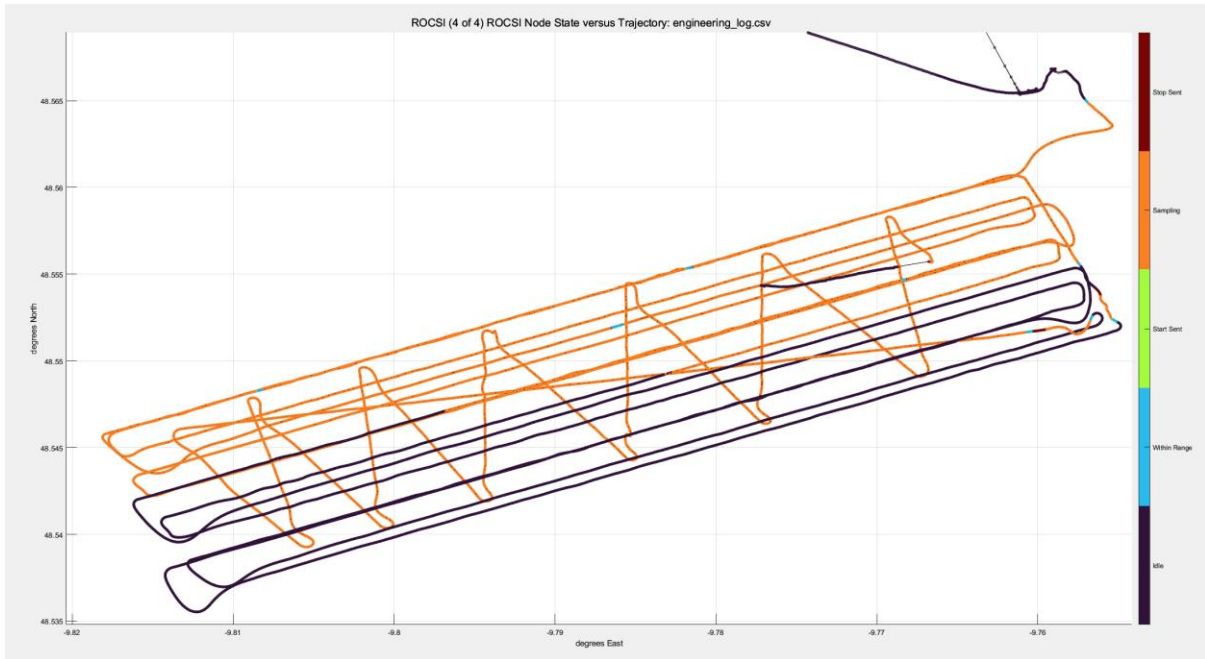

Fig. 7.100 Map of ROCSI Stages for mission A5M44

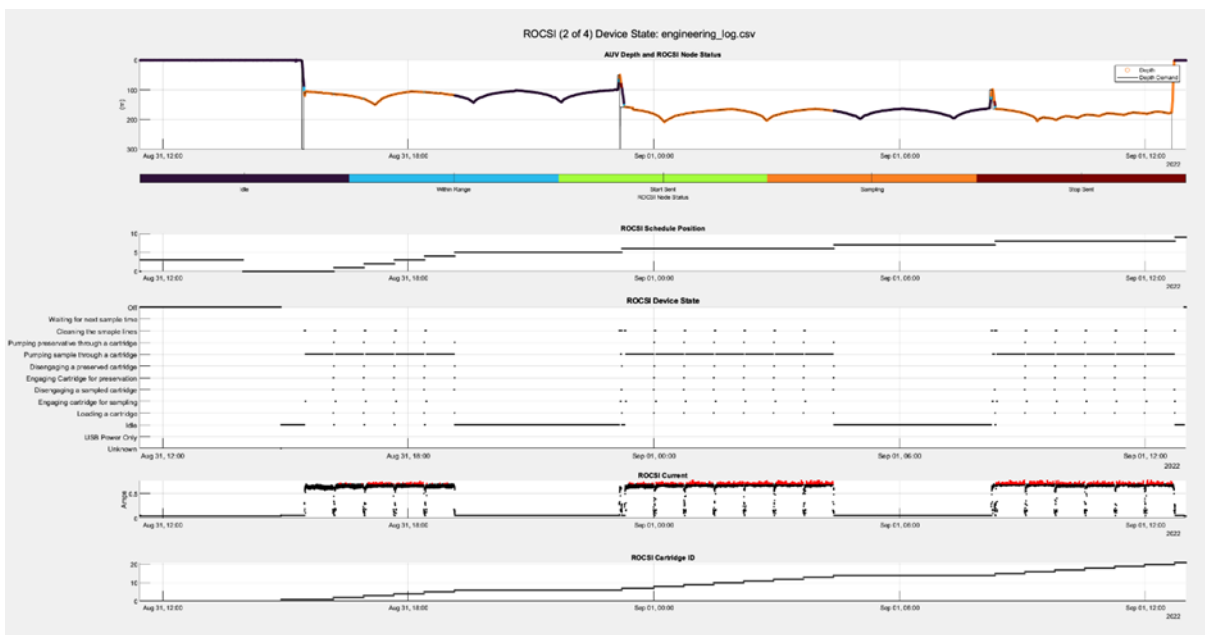

Fig. 7.101 ROCSI diagnostic plots for mission A5M44

7.1.8.16. Autosub5 M45 Mission Summary

7.1.8.16.1 Mission Statistics

Table 7.98 Details of mission A5M45

Mission Identifier	A5M45
Start Time	02-Sep-2022 13:07:33
Time Elapsed	4.07 Hrs
Distance Travelled	18.4708 Km
Start Coordinates	48.5465 deg N, -9.8082 deg E
End Coordinates	48.5645 deg N, -9.7529 deg E
Max Depth	204.7517 meters
Minimum Altitude Recorded	2.97m
Start Battery Voltage / Start State of Charge	57.876V / 96.5%
End Battery Voltage / End State of Charge	56.918V / 82%

7.1.8.16.2 Mission Plan Description

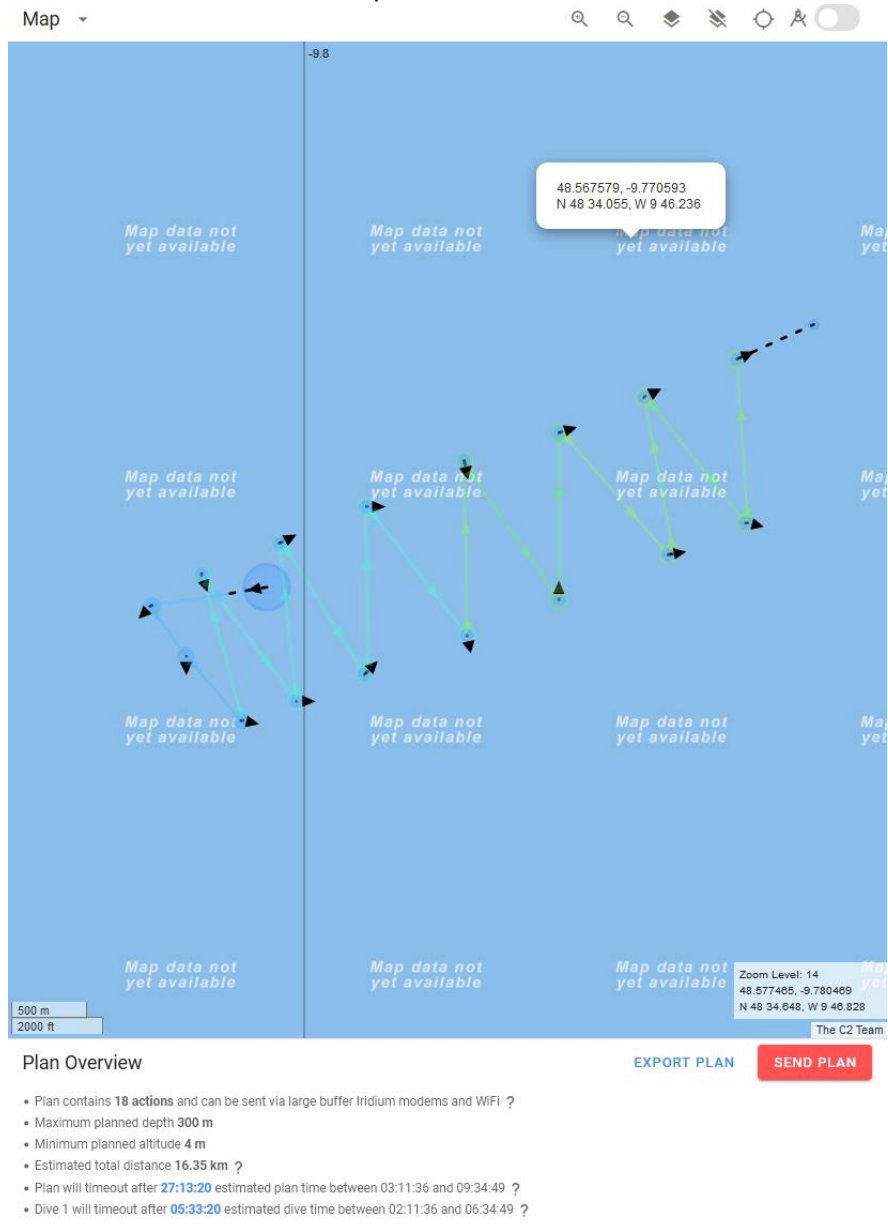

Fig. 7.102 Screenshot of planning module layout for A5M45

7.1.8.16.2.1 System Spec

Table 7.99 AUV system specs for A5M45

Wings	-3 degrees, middle position
Estimated Battery Use	25 KWh

7.1.8.16.2.2 Navigation

Table 7.100 OCS parameter specifications for A5M45

Navigation Solution	Localiser
USBL Telemetry	Required

7.1.8.16.2.3 OCS Critical Parameters Spec

Table 7.101 OCS parameter specifications for A5M45

Parameter	Value
No_contact_timer	24 hours
Safety_min_alt	1m
Safety_max_depth	4500m
Iridium_period	5 mins
Flight_style_depth_params	Kd:0.02, Ki:0.002, Kp:0027, anti_wind_up 0.06-0.02
Cross track correction	true

7.1.8.16.2.4 Trigger Configuration

Table 7.102 Trigger Configuration for A5M45

Autosub 5 Trigger Mode	Autosub5_3m_camera_5ms
Norbit FLS Mode	Fls5mAlt_400kHz_DY152

7.1.8.16.2.5 Payload Settings

Table 7.103 Payload settings for A5M45

Device	Required (Y/N)	Mode
9+ CTD	Yes inc DO	N/A
AESA Camera	Yes	1Hz
Norbit Bathy	no	
Edgetech 2205	no	
Wetlabs BBRT	Yes	N/A
NOC ROCSI	no	no
Applied Physics Magnetometer	No	Magnetometer was never plugged back in.

7.1.8.16.2.6 ADCP/DVL Settings

Table 7.104 ADCP/DVL settings for A5M45

Setting	ALR Default Value	Requested Values
Water Track Start range(m)	8.5	1
Water Track bin width(m)	96	37.5
Number of Bins	12	75
Depth Cell Width (cm)	800	100

7.1.8.16.2.7 ROCSII Settings

Table 7.105 ROCSI Settings for A5M45

Min Depth	Max Depth	Clean	Number of samples	Litres	Time out
160	400	1	12	2	1200

7.1.8.16.3 Mission Narrative

Due to the failure to capture images on AS5M044, the AUV was deployed on AS5M045. The survey was just the camera portion of the AS5M044 survey and was squeezed into the end of the cruise. The camera survey was a success. The AUV also collected 10 ROCSII samples

7.1.8.16.4 Annotated Engineering Plots

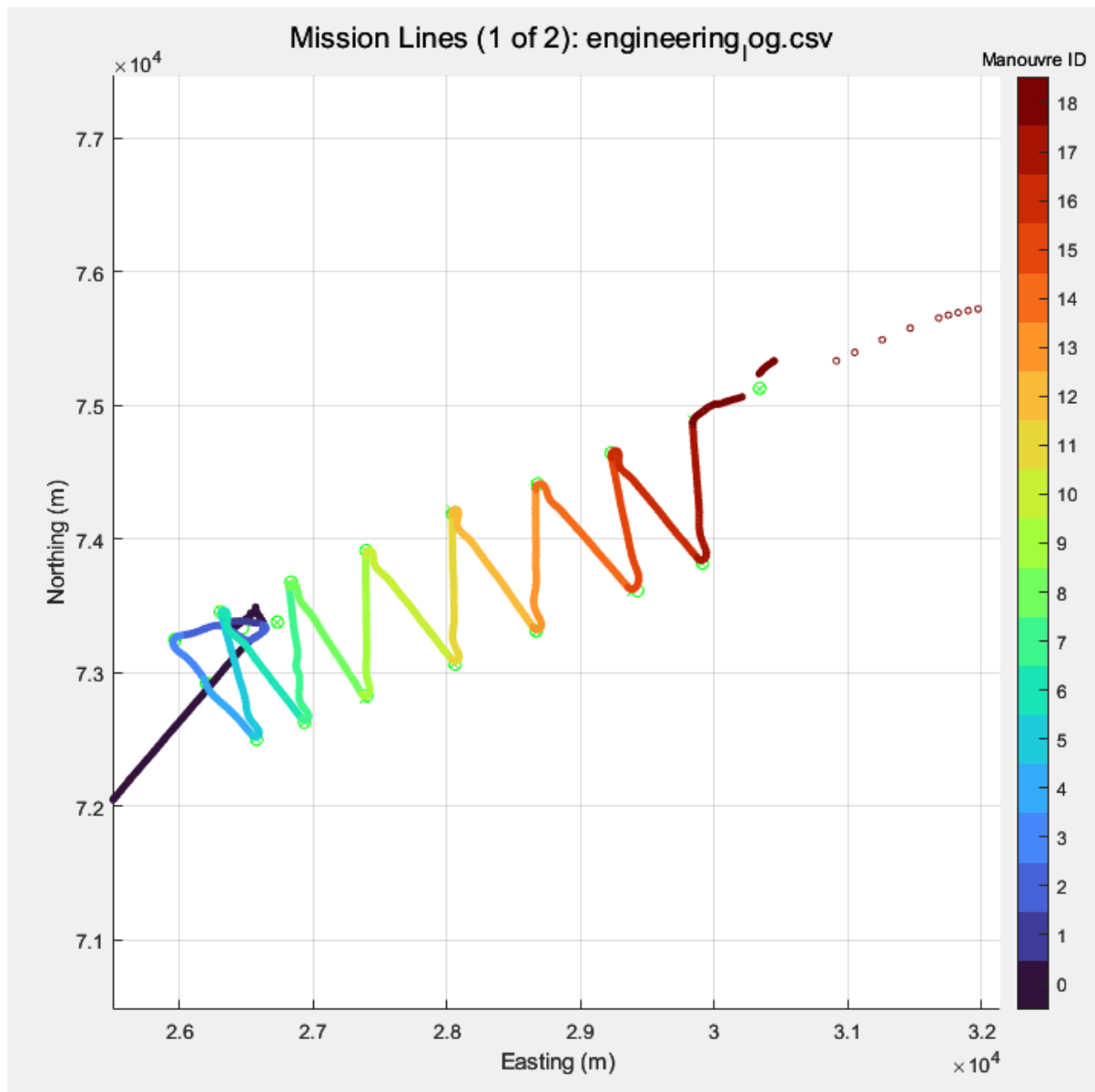

Fig. 7.103 2D navigation for mission A5M45

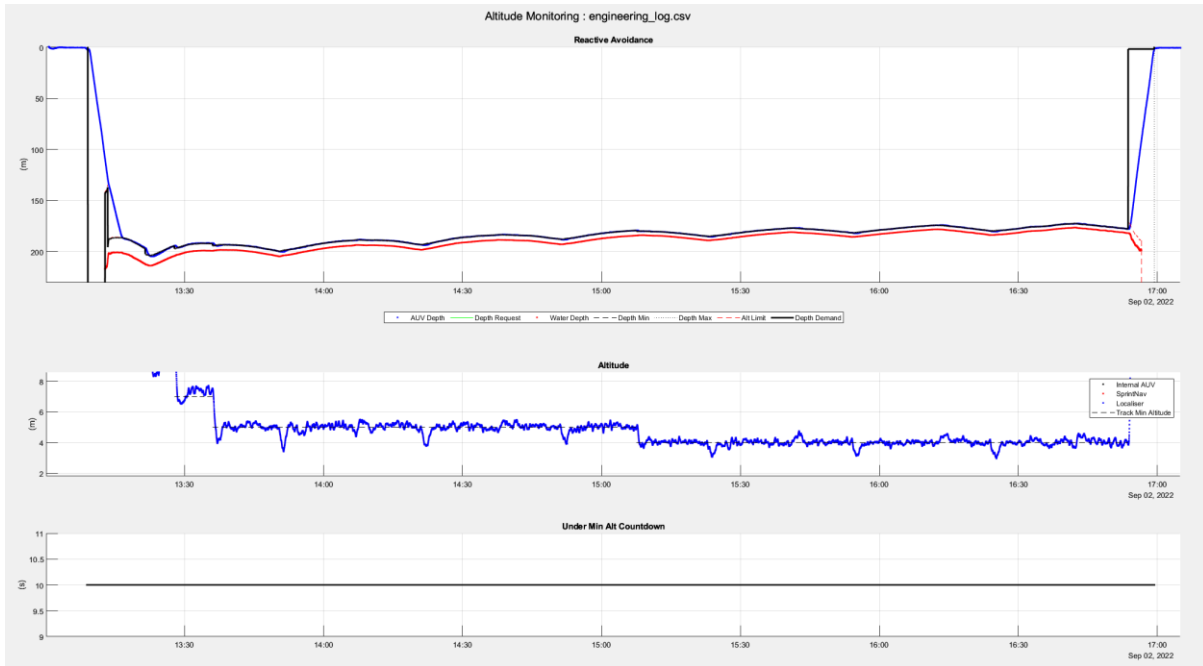

Fig. 7.104 Vehicle altitude for mission A5M45

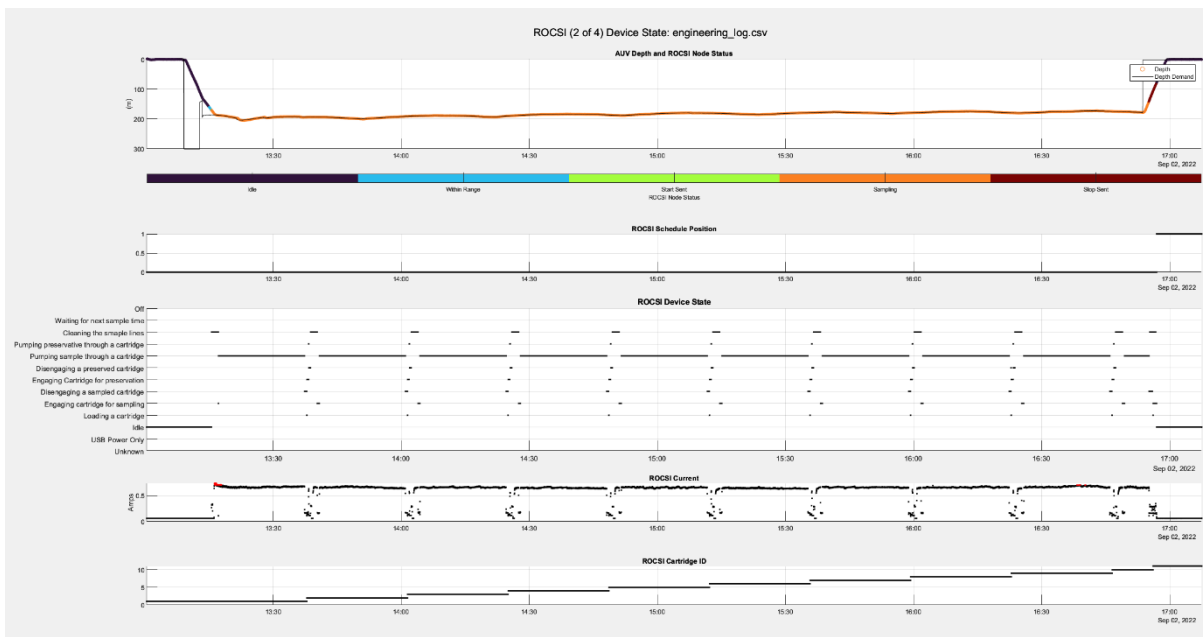

Fig. 7.105 ROCSI statistics for mission A5M45

7.1.8.16.5 Mission Initial Examples

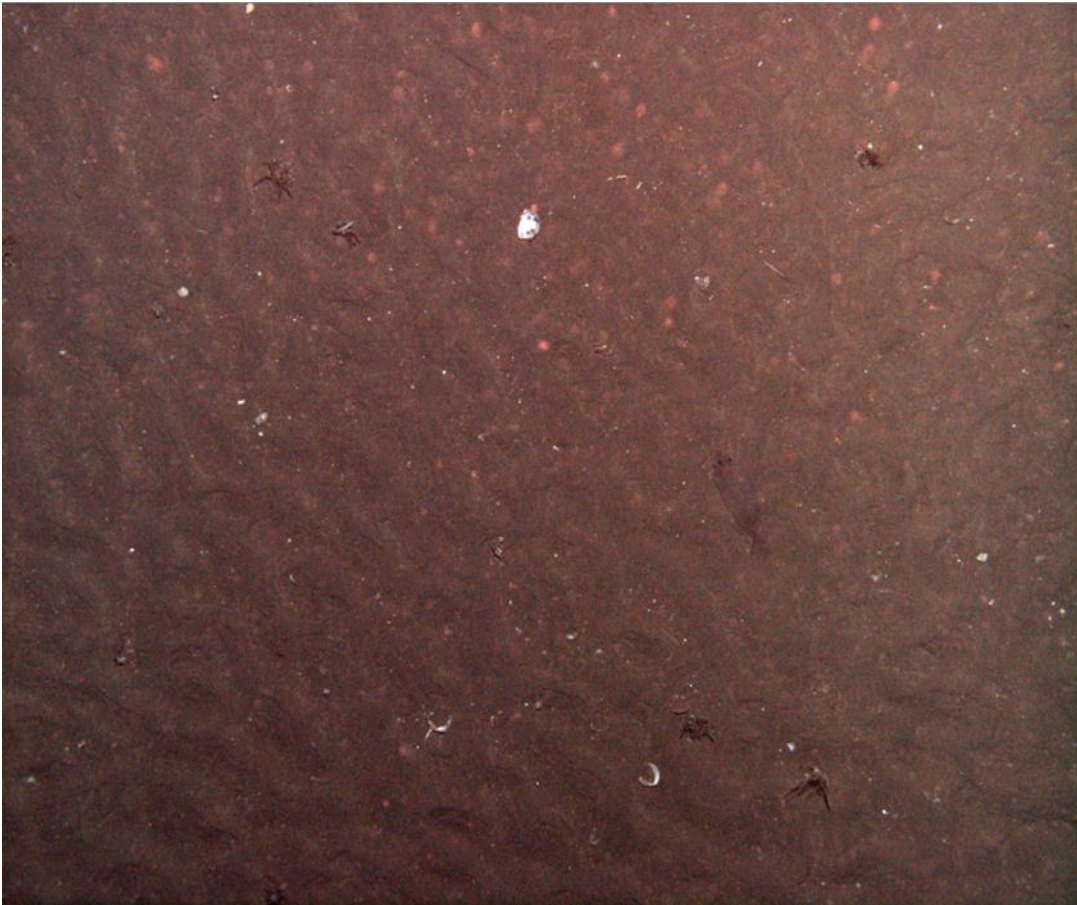
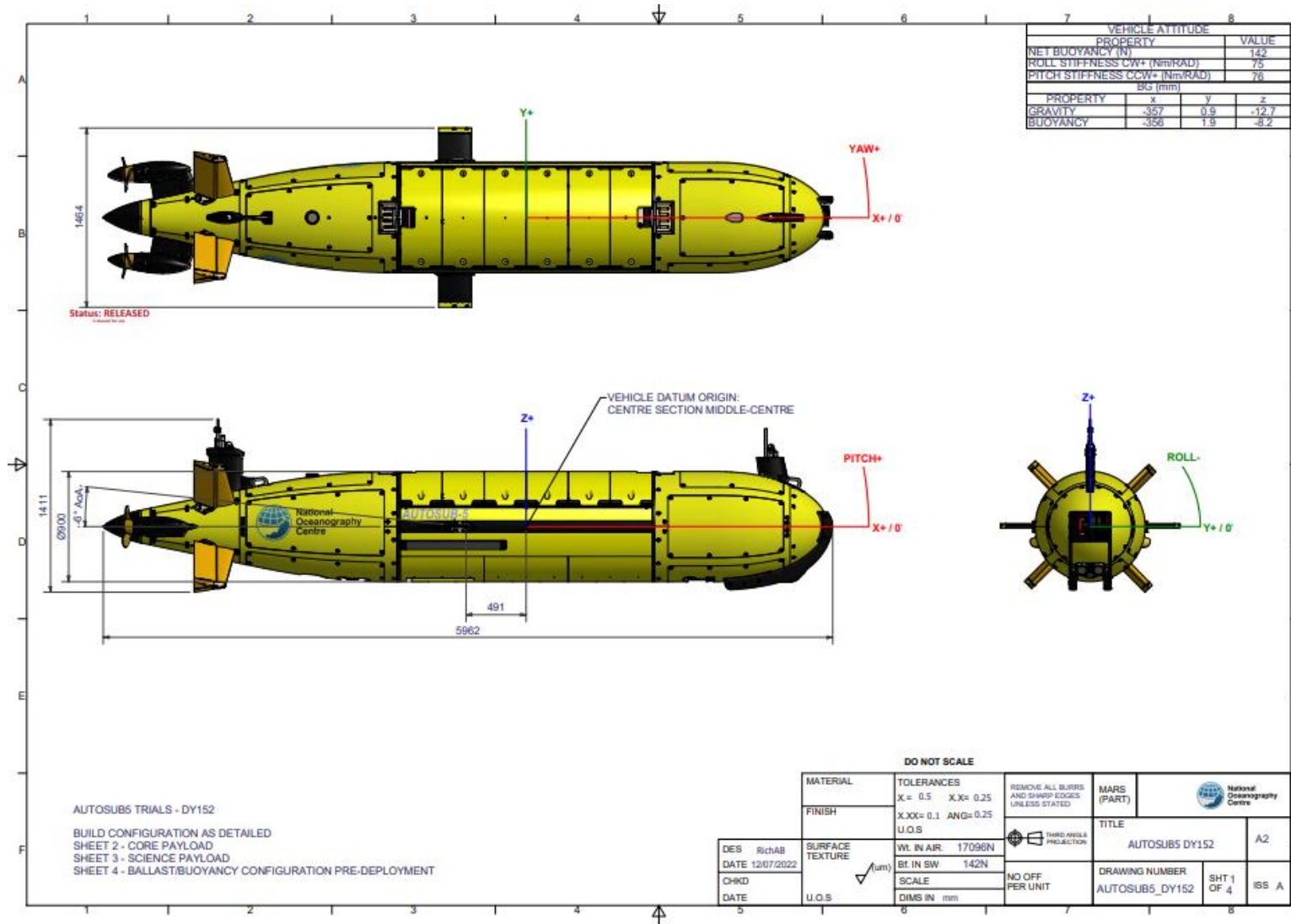
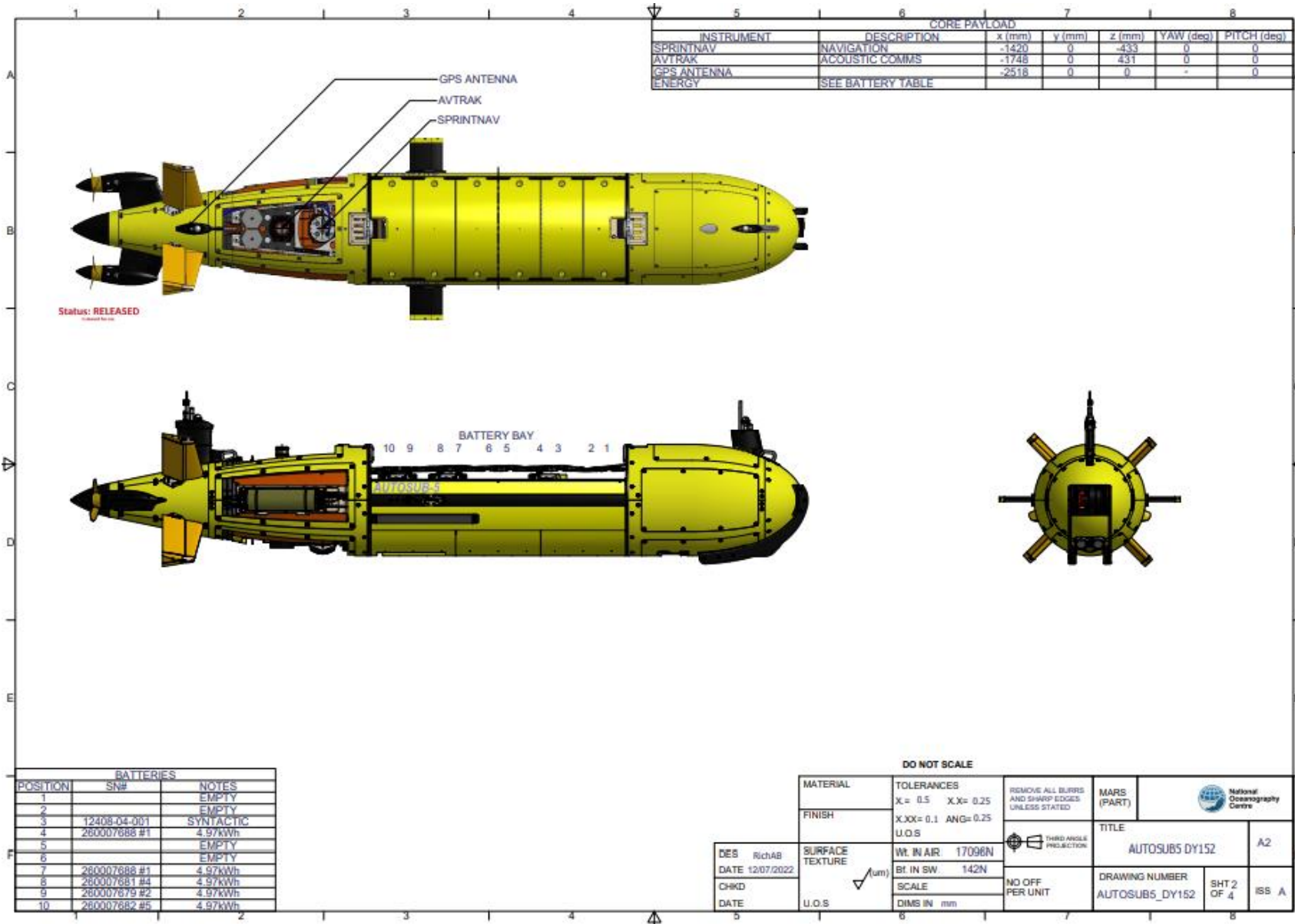
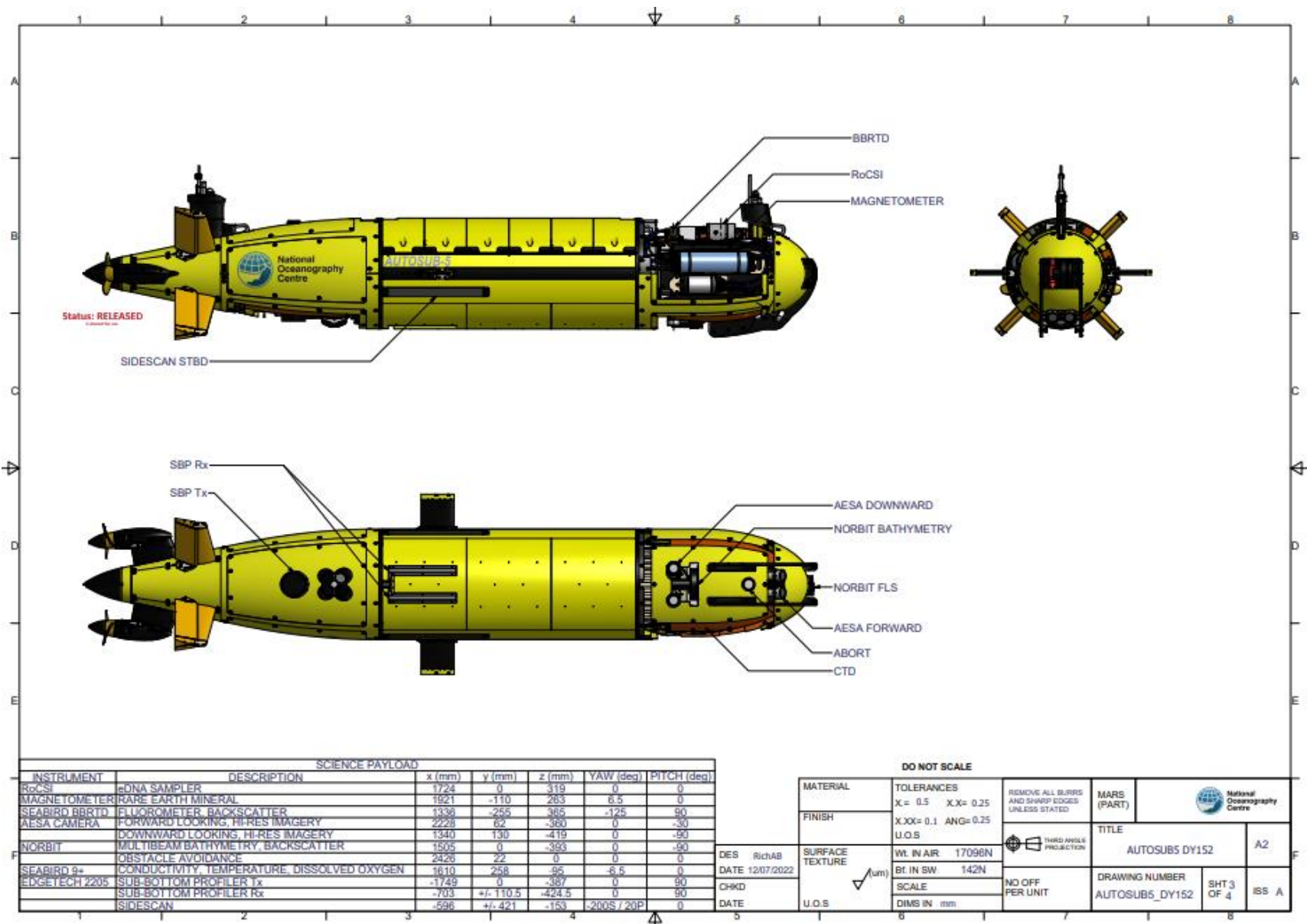

Fig. 7.106 Example photograph from mission A5M45

7.1.9. Autosub5 Measurements







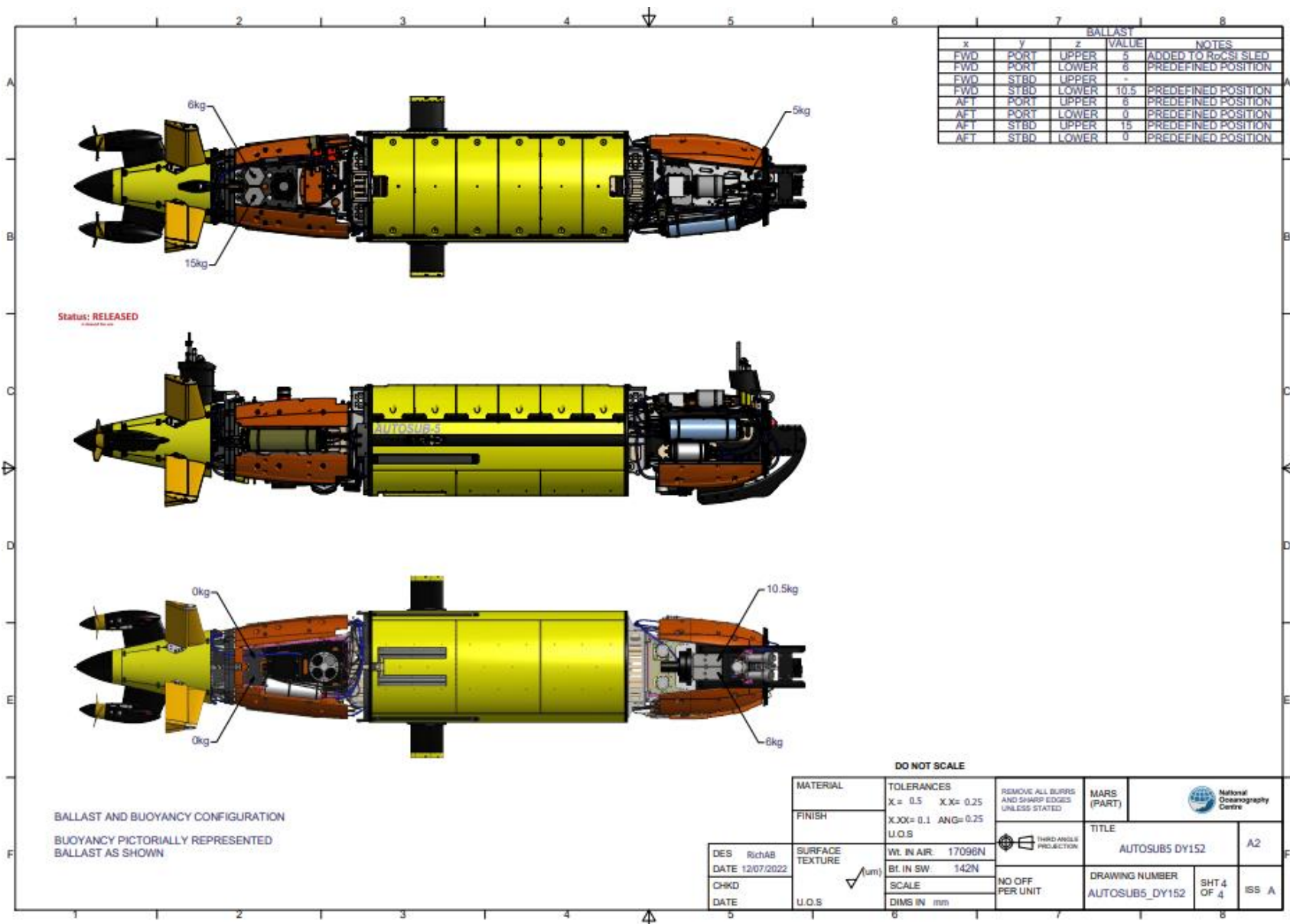

BALLAST				
x	y	z	VALUE	NOTES
FWD	PORT	UPPER	5	ADDED TO RECSI SLED
FWD	PORT	LOWER	8	PREDEFINED POSITION
FWD	STBD	UPPER	-	
FWD	STBD	LOWER	10.5	PREDEFINED POSITION
AFT	PORT	UPPER	8	PREDEFINED POSITION
AFT	PORT	LOWER	0	PREDEFINED POSITION
AFT	STBD	UPPER	15	PREDEFINED POSITION
AFT	STBD	LOWER	0	PREDEFINED POSITION

Status: RELEASED

BALLAST AND BUOYANCY CONFIGURATION
 BUOYANCY PICTORIALLY REPRESENTED
 BALLAST AS SHOWN.

DO NOT SCALE			
MATERIAL	TOLERANCES	REMOVE ALL BURRS AND SHARP EDGES UNLESS STATED	MARS (PART)
FINISH	X = 0.5 X,X= 0.25 X,XX= 0.1 ANG= 0.25 U.O.S		
DES RichAB	SURFACE TEXTURE	THIRD ANGLE PROJECTION	TITLE
DATE 12/07/2022	WT. IN AIR 17096N BT. IN SW 142N		AUTOSUBS DY152
CHKD	SCALE	NO OFF PER UNIT	DRAWING NUMBER
DATE	DIMS IN mm		AUTOSUBS_DY152
			SHT 4 OF 4
			ISS A

7.1.10. Autosub5 Co-ordinate frame

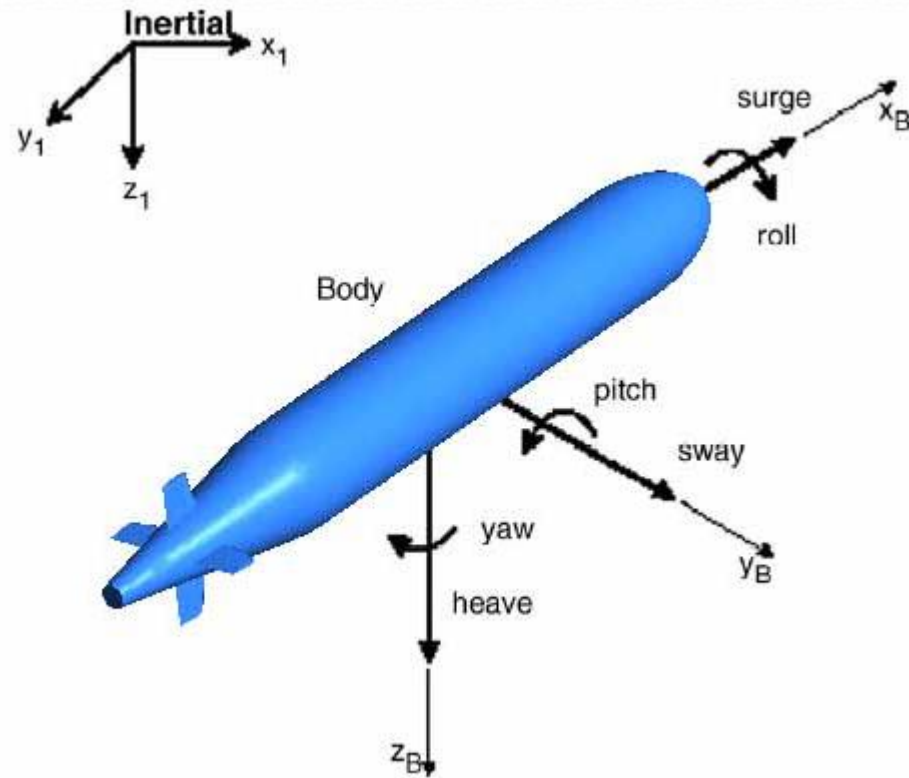

On-board control system - Axis System

Inertial Z - Depth Positive Down

Body Fixed x - positive towards the bow

Body Fixed y - positive to starboard

Body Fixed z - positive down

φ Roll clockwise looking forwards

ψ - Yaw clockwise looking downwards

θ - Pitch positive nose up

Position - Latitude: positive North

Position - Longitude: positive East

ALL Control Surfaces Trailing edge up is +ve (generates a nose up pitching moment)

7.2. ISIS ROV Technical Report

Operational Team: Dave Turner, Russell Locke, Josue Viera, Emre Mutlu, Martin Yeoman, Steven McDonagh, Will Handley

7.2.1. Mobilisation

Southampton (NOC): 02th Aug to 5th Aug 2022

The Isis ROV system was mobilised in Southampton. This was a straight forward installation with a 9000kg installation load test carried out.

All containers and electrical installation were checked by the Chief Engineer and ETO.

The ship sailed at approximately 11-00 hrs on the 6th August 2022

7.2.2. De-Mobilisation

The ship arrived along-side at NOC Sun 4th Sept 2022 at approx. 17-00hrs

Due to potential weather the vessel departed the work site @ 00-01hrs Sat 3rd Sept. Unfortunately, due to this we were unable move the ROV from the LARS, so that the system could be dissembled at sea. With the additional day alongside at NOC (Mon 6th) the ROV was moved and the LARS stowed. The remaining hydraulics were disconnected and the system made ready for lifting.

The LARS remained in position on the port side for transit to Caldera, Costa Rica.

The traction head, storage drum, HPU and associated base plates were removed from the vessel and located into shipping containers – These containers were then loaded back onto the vessel for transit to Caldera.

All other containers, including the ROV were removed from the vessel – and re-located into their positions at NOC

7.2.3. Operations

Two teams of three techs went onto the following watch patterns with Dave splitting the watches (6hrs on each watch). During the 12hr period between 10-00hrs and 22-00hrs the ROV was programmed to be launched and recovered. During the launch/ recoveries from 04-00 to 16-00hrs Russell would cover the winch and LARS operations, teaching Martin the over-side operations at the same time. Also, during this period Dave oversaw the training of Emre in the Pilot role. For the opposite 12hrs Dave would cover the winch and LARS operations, teaching Steve the over-side operations at the same time. Will and Josue both being experienced pilots covered the piloting of the vehicle between them

04-00hrs to 16-00hrs

Russell Locke
Martin Yeomans
Emre Mutlu

16-00hrs to 04-00hrs

Josue Viera
Will Handley
Steve McDonagh

10-00hrs to 22-00hrs

Dave Turner

All launch and recoveries were generally carried out between 10-00hrs and 22-00hrs, with some slippage to the left during the cruise. Typically, the ROV was deployed between 18-00hrs and 20-00hrs, working throughout the night and then being recovered 12 to 13hrs later. The AUV was generally deployed before the ROV and recovered the next day following the ROV recovery.

From the previous expedition, the 50m/45° cone added to the vessel drawing imported into the Sonardyne system was used. This helped the ROV pilot with the positioning of the ROV relative to the ship, limiting the potential wire angles from the docking head. This worked well also in enabling the ships officers to make any heading changes to the vessel, in such that they could manoeuvre the vessel whilst changing the heading keeping the ROV in the same position.

For all deployments the umbilical WMT beacon was attached a few metres up from the last football float. This gives a good indication as to how far the umbilical is away from the vessel and how far the ROV is away from the vertical part of the wire.

- Eight football floats were attached to the umbilical, with the two attached approx. as close to the ROV as possible (allowing for vessel heave and safe attachment) with a further six floats attached with an 8m spacing.
- The umbilical beacon was attached at 150m wire out
- A delta of approx. 30 to 40m was maintained.
- An approx. distance of 50 to 100m was maintained from the port side of the vessel. (Sonardyne 50m /45° cone)

7.2.3.1. Handling Systems

7.2.3.2. Hydraulic Power Unit (HPU)

The HPU worked well for the duration of the cruise, with no problems reported.

7.2.3.3. Storage Drum/Traction Winch

Worked well throughout the duration of the cruise. Some slack was seen appearing on the top and bottom of the sheaves of the traction winch (TW) when hauling in during the ROV recovery and was notably when the vehicle was within approx. 200m of the surface with less loading on the cable. In an attempt to remove these loose turns the winch was hauled and veered. Unfortunately, this only marginally improved the situation. In an attempt to remove the loose turns the sheaves were lubricated with carnation oil, marginally improving the situation. In addition to this a temporary guard was made and clamped to the traction head preventing the umbilical from jumping off the sheaves.

Post Dive 390 the storage drum drive chain was tightened.

Some discrepancy in the lays on the inboard side of the storage drum was noticed prior to the deployment of Dive xxx. With the cable deployed these were removed - as the cable was hauled in the alignment of the umbilical through the change at the end of the drum was monitored to make sure it laid correctly on the drum. No further issues encountered.

7.2.3.4. Storage Drum/Traction Winch Base Plate

When the storage drum was located onto the base plate, one of the port-side tombstone holes did not line up with the tapped hole in the storage drum. The tombstone hole was marked with a paint pen.

7.2.3.5. Launch and Recovery System (LARS)

During the mobilisation, a couple of the LARS bedplate holes were slightly out of alignment making it difficult to bolt down. A large crowbar was used to help with this alignment.

The complete system was load tested to 9000kg using the spectra test rope, traction head, storage drum, and a water bag supplied by water-weights. At each 1000kg interval the winch was hauled/veered until 7000kg was achieved. (Dynamic Test)

Ref test cert supplies by IMES International Cert No. POR01054/00001/T01

On the recovery of dive 384, it was noted that a noise was coming from the LARS head. Upon inspection, it was found that the tugger wheel bolts were coming loose and grinding against the side plate.

The wheel was replaced, the hub was re-tapped, and heavy-duty Loctite was used to secure the bolts.

Following this the tugger wheel bolts were checked before each dive, as part of the post dive procedure. It was noted that the Loctite had only partially worked with two bolts starting to work themselves loose again. These were tightened on each occasion.

7.2.3.6. **Umbilical**

The umbilical was mechanically and electrically terminated and load tested after the mobilisation. A load of 7000kg was applied and held for 5 minutes. (SWL of 5600kg)

Ref test cert No. UMB-03-011

Following some concern with the Jetpower4 unit and high current values, it was thought that some issue with the umbilical was occurring. In an attempt fault find this, the termination and 50 meters was removed. With the Jetpower4 issue resolved a new termination was made.

The umbilical was again mechanically and electrically terminated and load tested.

Ref test cert No.UMB-03-012

The attenuations for each of the new fibre connections were recorded from the vehicle end to the control container patch panel.

The attenuation for each fibre was recorded as:

Black	1310:	6.72dB (-36.02dBm)	1550:	5.35dB (-30.96dBm)
Red	1310:	3.98dB (-33.29dBm)	1550:	3.39dB (-29.00dBm)
Grey	1310:	5.58dB (-34.85dBm)	1550:	4.35dB (-29.95dBm)

Red fibre - For vehicle telemetry

Grey fibre - For CWDM (cameras)

Black fibre – Spare

During the ascent of Dive 391 at approx. 500m wire out the vehicle lost telemetry/power and was recovered as a dead vehicle. Following this the termination was removed and approx. 80m of the umbilical cut off.

The umbilical was again mechanically and electrically terminated and load tested.

Ref test cert No.UMB-03-013

The attenuations for each of the new fibre connections were recorded from the vehicle end to the control container patch panel.

The attenuation for each fibre was recorded as:

1310 Ref -29.3dBm

1550 Ref -25.37dBm

Black	1310:	6.60dB (-35.9dBm)	1550:	6.84dB (-32.19dBm)
Red	1310:	5.08dB (-34.41dBm)	1550:	5.55dB (-30.91dBm)
Grey	1310:	6.30dB (-35.59dBm)	1550:	6.11dB (-31.45dBm)

Red fibre - For vehicle telemetry
 Grey fibre - For CWDM (cameras)
 Black fibre – Spare

Following Dive 397 (at PAP) the umbilical was disconnected from the HV junction box, and gimbal assembly, so that it could be inspected for any turns that may be developing, and to enable these turns to be removed. All appeared ok. The termination was re-assembled and the vehicle tested for its next dive back at the Whittard Canyon.

The exposed black core of the Umbilical on the side of the storage winch was not secured and was moving as the drum rotated. Some minor chafing was found so the core was protected with slit hose and secured with tyrap to prevent movement during drum rotation.

Following the last dive 50m of the umbilical was removed and discarded.

7.2.3.7. **CCTV & Lighting**

The new HD system consisting of two fixed, one varifocal zoom looking at the A-Frame and one PTZ dome camera for deployments was used on this expedition. So far there have been no issues with the operation of the cameras. The software used for the camera may need to be updated and this can be done back at base.

7.2.4. **ROV External and Sampling Equipment**

7.2.4.1. **USBL**

During the mob, it was found that the Starboard pole had been removed for repair during refit. Communicating this issue to the affected parties was not done prior to the cruise.

This repair should have been followed by a CASIUS calibration on the post refit trials to guarantee the operation and precision of the USBL system. Therefore, the Starboard head was not operational and could not be used on JC237. This had an impact on the ROV operations, since the Starboard head is the most appropriate head for ROV USBL tracking.

7.2.4.2. **Sonardyne Beacons**

7.2.4.2.1 **Compatt 5 Midi Beacon**

The Compatt 5 beacon address 210 was attached to the ROV for the duration of the cruise. This beacon was only on the vehicle for back up and was not tracked during the dives.

7.2.4.2.2 **G6 WMT Beacons**

Beacon 2702 was used to track the ROV and 2709 was used to track the umbilical. Beacon 2702 is trickle charged from the ROV and remained on the vehicle for the duration of the cruise.

On dive 392 Beacons were swapped around since the ROV 2702 was suffering some intermittent dropout on comms (this had happened several times on other dives).

A new SVP was loaded into the Ranger topside unit, as and when they were carried out by the Ships System team.

After dive 395, the beacons were again swapped back since 2709 was working fine during all the dive except at the end when it stopped pinging.

On post-dive, M. Kingsland investigated the beacons settings and changed the gain levels (See the screenshots below) to improve the deep range of the beacons. Using the standard head HPT5000 clearly reduces the SNR compared to the usual “deep optimized” head HPT7000. This seemed to improve slightly the pinging at 4800m, but performance is not as good as seen in previous cruises with the big head.

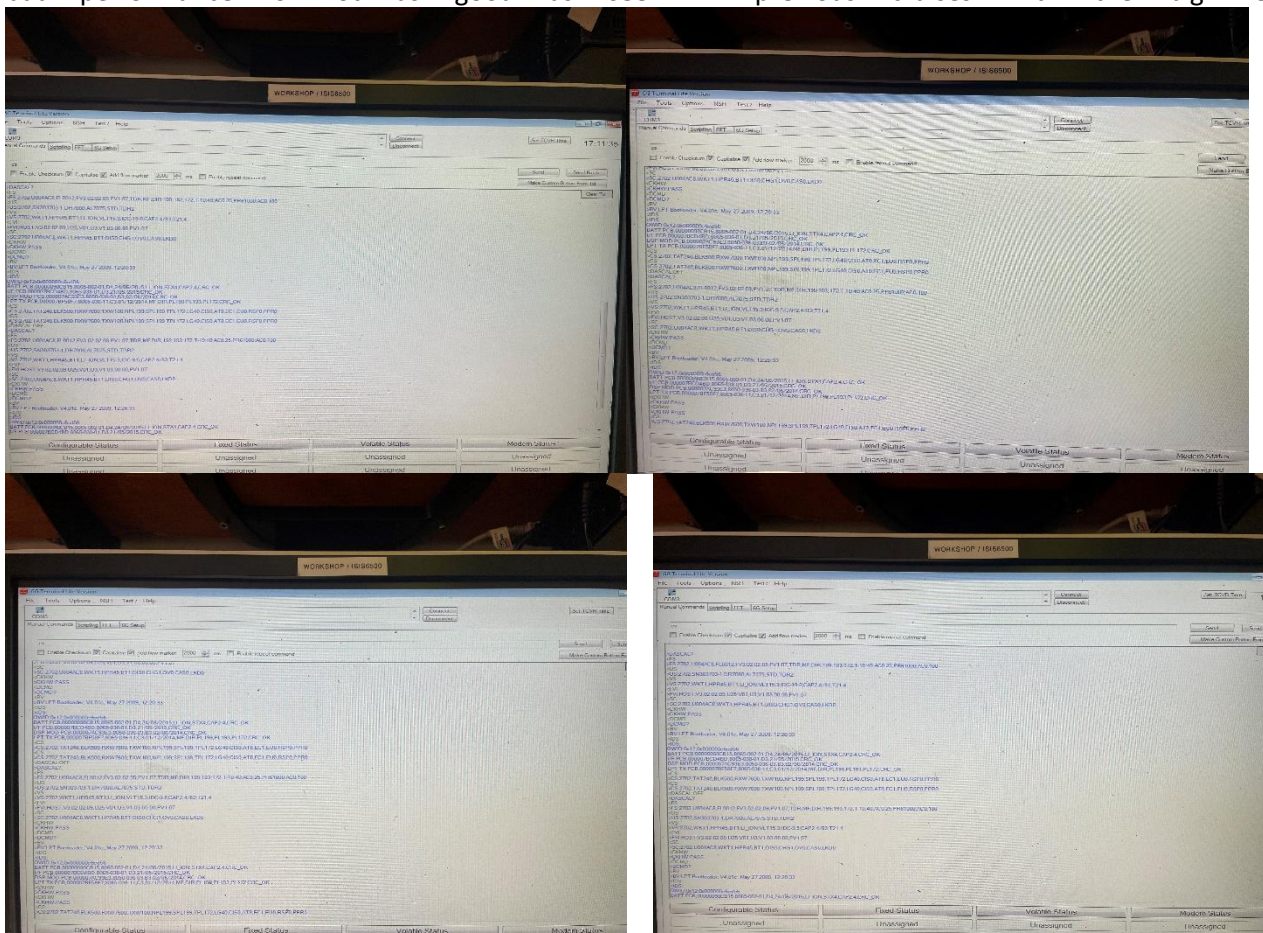

Fig. 7.108 Screenshots of Sonardyne settings

7.2.4.3. Football Floats

8 x 6000m floats were used for the duration of the cruise.

7.2.4.4. Suction Sampler

During one dive the suction sampler lost most of its suction making sampling difficult when used. The hydraulic pressure was increased, flow rate increased and manifold settings were increased. This did little to improve performance. During the post dive the pump was tested, and worked as expected. On the following dives no further issues were encountered.

7.2.4.5. Push Cores

Future modifications/recommendations/maintenance:

- Service units and make ready for next cruise.
- If push core T handles were modified to reduce height of handle by about 30mm, then push cores could be mounted on the position of the drawer that goes under forward shelf.

7.2.4.6. **Magnetic Tubes**

Future modifications/recommendations/maintenance:

- Service units and make ready for next cruise.

7.2.4.7. **Niskin Carousel**

Future modifications/recommendations/maintenance:

- Service indexing mechanism. Inspect and replace rubber tubing if necessary.

7.2.4.8. **Nets/Scoops/Bio Box**

7.2.4.8.1 Scoop

Future modifications/recommendations

- Consider making a new scoop out of perforated stainless-steel sheet with T handle mounted in middle of scoop. This would make it easier to use and it would stop delicate samples getting stuck in the chicken wire.

7.2.4.8.2 Net

Future modifications/recommendations

- Consider making a new net. Fitted with a ring of stainless flat bar to give hard edge for scraping. Net to be attached via holes in back of flat bar. Current net with bag wrapped around ring does not work for trying to scrape samples off hard substrate.

7.2.4.8.3 Bio Boxes

Future modifications/recommendations

- The Swing arm and large biobox lids are not held open with enough force to stop the current encountered in the Whittard Canyon from sometimes closing the lid during sampling
- The bioboxes do not hold water on deck. Sample quality when operating in hot climates will be improved if the cold bottom water does not drain out of the boxes during recovery. Consider sealing boxes so the water does not drain. Sealing lids would be ideal, but the boxes would be greatly improved if they don't drain.

7.2.4.9. **Reson Installation**

Prior to the cruise, the Reson system was tested back at NOC. It was found that the topside PC unit was showing a fault on the internal PCI serial card. A fix was done using an external USB-Serial unit to receive the serial feeds from the ROV vehicle. The whole system was then tested and was signed off as working. Note this is an old XP machine which was supplied back in 2011 with the Reson Multibeam system.

During the mob, the topside unit was connected with the ship's feeds (which are not available back at base, eg: Ship's GPS, Gyro and clock PPS signal). It was found that the topside unit was receiving the ZDA UPD message, but was not syncing to the clock PPS signal. After some fault finding on the ships installation and measuring with an oscilloscope, the signal was verified to be getting to the Reson computer.

The PPS signal path is: In the Gyro room, the Seapath PPS Signal (left BNC connectors, not the PosMV) goes to JB30 Coax-7. Then it goes in the JB28 on the Aft-Hold (Coax-1). This port is patched to Coax7. It then arrives to JB12 Coax-1 on the Hangar. This connection is then accessible on the BNC cable outside the JB12 (sealed in the waterproof plastic bag to prevent corrosion).



Fig. 7.109 Photo of BNC Coax in the Gyro Room, on the Seapath PPS distributor unit

The Reson computer was then disassembled, inspected and all the PCI boards were extracted. Sequentially, one by one were re-seated and the computer was powered on and tested. This seemed to fix the issue and the PPS signal was successfully received by the Reson computer. A full system check was done again, and verified it was working, ready for the cruise.

It was also noted that the second display was also sometimes not enabled when the PC was turned ON. This was fixed by entering the Windows Display settings and enabling the “extend desktop to this display”.

7.2.4.10. Rock Drill

Worked well for the two dives it was asked for. Unfortunately for the first dive the substrate was to ‘sticky’ to drill, resulting in the sample staying in the drill bit. This was later recovered as a good sample once extracted from the bit. The second attempt worked slightly better allowing one core to be extracted with the ‘catcher’ and the second remaining in the drill bit again.

7.2.5. Isis ROV

7.2.5.1. Low Power Junction Box

The science bus is made up of a ten channel Subconn 8 pin connectors. These connectors can provide 24V and up to four Amps, including two channels for 12V devices. One of the channels is pre-allocated for the ROV CTD Sensor, but the other nine are available to science (final quantity depends if they require other ROV sensors). As a backup, the AUV Trittech unit can be plugged in to the Science Bus 8 which is already configured in the ROV Trittech Software.

The standard configuration is:

Seven channels for Science, SciB_6 for Turbidity, SciB_8 for AUV Trittech Backup unit, SciB_10 for CTD.

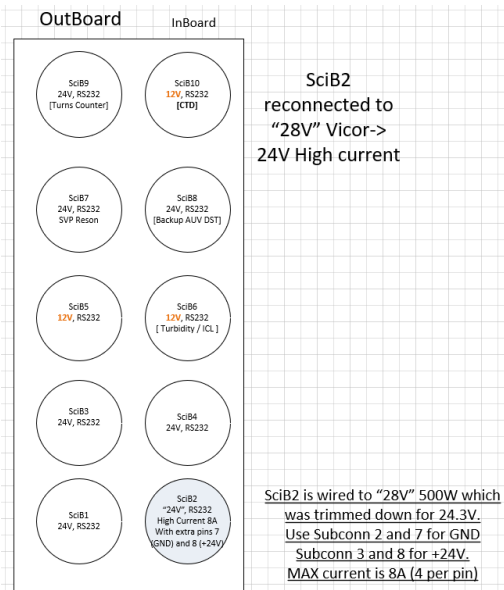

Fig. 7.110 Configuration of the junction box

7.2.5.2. High Power Junction Box

For DC deck supply issues see section 7.2.6.2

7.2.5.3. Low Power Tube and Telemetry Tube

On Dive 396, during the pre-dive, the vehicle was powered on but on the GUI there was no info updated (no volts were being displayed). It was found Topside crashed, showing an error message continuously of: "sed/cb debug..."

The vehicle was fully powered down, topside powered off and the Focal Console unit powered down. Topside was then powered on first. Once it has finished after a couple of minutes its initialisation (by pressing Enter, you get a "table" displayed), the vehicle was powered on and no problems were found.

On the deployment, when the vehicle was being powered on the A-frame, everything came on except the Port Kraft and the Hyd Pressure, which could not be turned on. After some investigation, it was found the group of wecons "65, 66, 67, 62" of the low power tube were not communicating (red on the GUI). Topside was again showing the error of "debug..." Topside was rebooted, but still was having the same issue with the Low power Wecons.

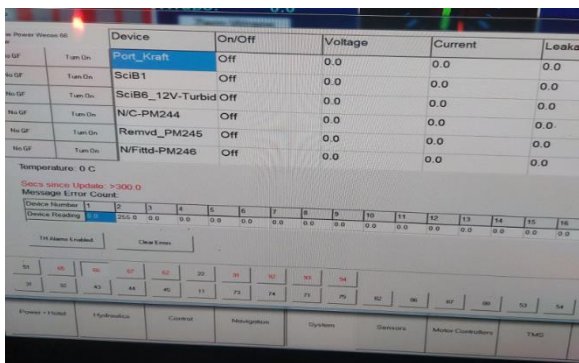

Fig 7.111 Wecons in red have an issue (ignore 91 to 94 which values belonged to the TMS)



Fig. 7.112 Normal operation of the HOTEL tab and GUI with standard GF

After an hour and some research, the vehicle was repowered on deck and it was fine. It was then decided to change to the backup topside PC just in case the PCI card of the master topside could have an issue. The serial

cables to Focal port 53 and 54 were disconnected and reconnected on both ends. The vehicle was then powered on again to test and worked correctly. Finally, the dive was relaunched and proceeded without issues.

If this issue happens again, it could be related to:

- Digibox number 2 (where all the wecons serial ports are)
- In the low power tube, one of the Wecons could be dodgy/faulty and therefore it will bring down the whole RS485 channel which is shared with the other three Wecons (happened on JC124, on the High-power tube).
- Could be the 5V Vicor powering the backplane of the low power tube. It is drawing 5.4 Amps, so worth checking the 6 pin molex connector (male and female) if they show a brownish colour, showing signs of overheating/wearing out. If this is the case, replace soldered molex and/or Vicor module + PCB (check resistors and jumpers before replacing it).

During the pre-dive checks for Dive 398 a problem was encountered when powering up on HV. The HV was applied in the usual way, but no volts were seen on the GUI. It was also noted that the telemetry stack was not communicating with the vehicle. Further attempts to power up resulted in the Jetway tripping GF – in addition it was now recorded that applying 1V the unit was outputting 50 amps and increasing to 4 to 5V the unit would trip. With a potential issue on the HV system and a communication issue to the vehicle it was decided that the Jetpower, umbilical, and transformers would be checked accordingly (For HV issue refer to Section 7.1 High Voltage System). And the telemetry would be looked into using the DC deck supply.

To investigate the comms issue the DC deck cable was hard wired to the tail on the vehicle, (bypassing the failed connector). With the vehicle powered on, the GUI would not update and the topside had no comms to the vehicle. Checking the Topside Focal unit, it was found that the Stack “A” of the subsea was working and communicating, but not the Stack “B”. The Stack A contains mainly the RS232 vehicle sensors. The Stack “B” is the RS485 stack to the thrusters, P&T and the Wecons. Since this second stack was not communicating, topside could not talk to the Wecons and therefore no actions/info on GUI were available.

Following this the telemetry tube was partially extracted from the vehicle, and the Vicor and PCB module 5-3 (which power the “FOCAL_B” = Focal subsea Stack “B”) was replaced. The vehicle was then powered again on the DC supply and comms were recovered.

During a thorough test, it was also found that a lot of sensors/instruments were not receiving power. On the GUI, the buttons were being enabled (going green) but the Volts and Current values were 0.0.

To get the vehicle operational a list of the failed sensors and instruments was made (separate report) with the essential ones highlighted for replacement. Both the low-power and high-power tubes were removed from the vehicle, replacing the essential Vicor, and PCB modules.

With this completed the vehicle was tested on DC, and then again on HV, and made ready for Dive 398.

7.2.5.4. Thrusters

During the launch of the Dive 387, following the ROV power-up and pre-dive checks, a GF of 17MOhms/40MOhms was noted. The cause of the GF was found to be the Fwd Lat thruster. Following the discussion, ROV was put back on deck for a quick connector service. After the Subconn connector servicing, the GF had improved and the dive went on. The GF had improved once the ROV was in the water and had further improved during the dive.

The following day, during the pre-dive checks of Dive 388, GF on the Fwd Lat thruster persisted. The power lead of the FL thruster was swapped with the power lead of the SV thruster, as well as the serial leads of FL and SV thrusters on the back of the topside Focal unit. This decision was taken to lower the impact in case of a thruster loss, considering the strong currents on the dive site.

After Dive 388, during post-dive checks, the GF on the GUI was seen to get as low as 3 MOhms. Considering the potential break of 1-2 days until the next dive due to approaching bad weather front, the decision was made to open the FL thruster DriveBlock pod to further investigate the problem. Meanwhile, the power lead coming from HV JB to the FL DriveBlock pod was plugged in to the SH thruster pod, to prove there was no GF in the PBOF Subconn lead. The lead had No GF.

Post dive of Dive 388 the resistors were tested and meggered. The resistor circuit is composed of three 150hm resistors (MP9100-15) in series ($15+15+15 = 45 \text{ Ohm}$), and then in parallel to another equivalent three resistors. This results in a final value of 22.5 Ohm ($45 \text{ Ohm}/2$).

It was found that two resistors needed to be replaced (one had a small crack on the ceramic heatsink on the back of the package encapsulation). They were showing around 30 MOhm, while brand new resistors and working ones were around 1000MOhm / 1GOhm.

Vehicle was then powered up and the AftLateral driveblok (which was powering the Starboard Vertical) and no GF was detected (AC GF reading was a solid constant 40000 KOhm = 40MOhm).

During Post Dive 387 it was noted that the SH thruster was leaking oil from its shaft seal. The unit was replaced with the spare. The removed unit was stripped down and the shaft seals and bearings replaced.

During the start of the deployment of Dive 391, whilst testing thrusters, prior to launch, a hard GF was seen on the SV thruster – currently configured to FWD lateral, following previous GF issues. The vehicle was recovered to deck and pod removed to investigate.

The brake resistors checked out good, whilst the male Subconn input connector showed a very low resistance and low megga on pins 1, 3, and 4 to the outer shell.

The connector was replaced, 'O' rings replaced on the pod ends. No further issues encountered.

During the connector replacement it was noted that some corrosion was present on the 'o'ring faces, and that the anodising was showing signs of wear.

7.2.5.5. **Hydraulic System**

Following each dive an oil sample was taken from the reservoir and inspected for water ingress. All samples appeared free of water.

Swing arms struggled to open beyond 3000m – new micro bore lines may be too restrictive.

7.2.5.6. **Manipulators**

7.2.5.6.1 Kraft Predator

Worked well for the duration of the cruise.

7.2.5.6.2 Schilling T4

During the post dive of 396 it was noted that the shoulder joint of the arm would not operate. (ram locked) From the manual it was identified that a couple of bleed screws for the shoulder ram were available. Upon cracking one of these screws, high pressure oil was encountered followed by a lower flow. With the ram (shoulder) now slightly drooping the arm was re-energised and able to function normally.

7.2.5.7. **Tool sled**

Worked well for the duration of the cruise, but some fixtures were broken when the tool sled was used to hold the bio box lid open by pinching it against the chassis of the vehicle, this was done as the current was side onto the ROV causing the lid to close.

7.2.5.8. **Vehicle Compensation System**

The vehicle main compensation system worked well for the duration of the cruise. Following each dive oil samples were taken from each junction box, to check for water ingress.

7.2.5.8.1 Thruster Compensators

The thruster compensators worked well with no faults.

7.2.5.8.2 Manipulator Compensators

The manipulator compensators worked well with no faults. Neither Schilling nor Kraft compensators lost any significant amount of oil during dives.

7.2.5.9. **Pan & Tilt Units**

The Kongsberg unit was installed into the pilot camera position, with the Mini Zeus camera mounted on it. This configuration worked well for the duration of the cruise with no problems reported.

7.2.5.10. **Cameras**

7.2.5.10.1 Mini Zeus HD (pilot)

Worked well for the duration of the cruise.

Following the buoyancy check on each dive, with the ROV just off the seabed, the camera was white balanced using the Kraft arm and white sheet mounted on the wrist arm.

7.2.5.10.2 HD P&T Dome Unit

Worked well for the duration of the cruise.

7.2.5.10.3 Scorpio

Unit SSC103 was used for the duration of the cruise

New Scorpio GUI created by Emre has been used for the duration of the expedition. No issues encountered.

7.2.5.10.4 Mercury

The rear facing Mercury camera worked well for the duration of the expedition.

7.2.5.10.5 Tooling Cameras

All tooling cameras worked well with no issues reported.

These are positioned in the following locations:

Draw 1 down looking	Bullet upward
Gauges/Suction sampler	Niskins
Draw 2 overhead	

7.2.5.11. **Lights**

7.2.5.11.1 DSPL Multi Sealite (LED)

These are positioned in the following locations:

- 1 x Bullet- Up Looking
- 1 x Gauges/Suction Sampler
- 2 x Aft facing

All units functioned well for the duration of the expedition.

7.2.5.11.2 DSPL Lumos (LED)

These are positioned in the following locations:

2 x Drawer, facing downwards
2 x Drawer fill in, under each manipulator

The two fill-in Lumos lights developed a ground fault, which went away when the lights were turned off. The connectors to the lights were cleaned and serviced and the GF went away.

There is a shadow under each arm when sampling. If the two fill in Lumos lights were angled slightly down, they could illuminate this area of shadow.

7.2.5.11.3 Apos 16 LED

During dive 387, unit SN 0000199 started to flicker and was disabled on the GUI. It was then swapped with a spare.

During dive 394, unit SN 0000201 started to flicker and was disabled on the GUI. It was then swapped with a spare.

7.2.5.12. Lasers

One pair of the NOC lasers were mounted onto the Scorpio stills science camera, and pair was mounted central to the vehicle below the science dome camera.

No faults occurred during the duration of the cruise.

7.2.5.13. CWDM F/O Multiplexor

Worked well for the duration of the cruise.

7.2.5.14. Sonars

7.2.5.14.1 Doppler

The Doppler 300KHz was used for the duration of the cruise.

7.2.5.14.2 Altimeter

During Dive 384, it was found the altimeter was not working. Emre amended the code to get the altimeter data from the RDI Workhorse to the overlay, it worked well for the duration of the expedition.

7.2.5.14.3 Trittech Imaging

This unit worked well for the duration of the cruise.

7.2.5.14.4 Digiquartz Pressure Sensor

The unit worked well for the duration of the cruise.

7.2.5.15. CTD

Worked well for the duration of the cruise. Unit with SN 4972831-0295 was used.

7.2.6. ROV Topside Systems

7.2.6.1. High Voltage System

While energizing the high voltage to carry out pre-dive 398 the JPT4 unit HMI display read 5V 100amp out and then the ground fault monitor evenly tripped and shut down the Jetway. After this happened a permit to work was opened so that the HV system could be worked on safely. Upon opening the HV junction box in the Jetway compartment a strong and distinctive odour was smelt. This was investigated and found to be the high voltage ground fault monitor sensor module. This module is used to step down the 3kV to a reasonable voltage which is sent back to the ground fault monitor. A safe isolation of the high voltage was carried out and the module

then removed from the junction box. Upon visual inspection the module had severe damage to its housing. The unit had cracked and had also been subjected to very high current which caused the internal resin to melt and seep out. It had instantly failed the visual inspection. An ohmmeter was then used to measure the internal resistance which was extremely low. Finally, an insulation resistance was carried out which the module failed to pass. Due to the devices age the conclusion would be that the insulation resistance has broken down overtime and this caused a dead short across the phases thereby producing a high fault current. It is due to this failure that the electronics in the ROV tubes experienced overvoltage damage. (Ref Section 6.3 Low Power Tube/Telemetry Tube). The module was replaced with a spare unit and the high voltage system was reconnected and the permit to work was closed out.



Fig. 7.113 Picture of the high voltage monitoring module

There are no more spares for the module and seeing as it is over 20 years old, highly unlikely that they can be bought. For the upcoming cruise the new MPUS ground fault monitor should be taken as a spare. In the future the fluid kinetics ground fault monitor will need to be replaced with a new unit. This replacement could take place during the install of the JPT4 unit.

7.2.6.2. DC Deck supply

With the first power-up on DC the ROV was not coming on (current consumption was 0). The deck LED “Deck cable connected” was on, proving the control box is detecting the cable and enabling the safety bypass. After some diagnostics and retries, the vehicle came back to life. It was later powered on HV and was fine.

Again, the following day the same issue occurred. It was suspected that the relays on the high power JB, on the vehicle, that enable the 240VDC was not switching correctly.

It was then found that the connector was not seating completely flush, and that by holding it tight, the relays in the high power JB were energized enabling power to the vehicle. The female connector was replaced on the deck cable, to see if it improved the connection with the male equivalent.

Unfortunately, this didn't improve the issue, preventing the DC deck power supply to be used to power the vehicle. It is suspected that the male pins are broken internally on the connector moulding making a poor connection. This male tail could not be replaced since the vehicle was already fully comped with oil.

It was intended that for the rest of the expedition the DC supply would not be used. Following issues with the HV system and the GF unit, it was decided that the deck cable would be connected to the vehicle via a terminal strip, removing the faulty connector from the equation, so that testing could be carried out.

With all tests complete the terminal strip was removed and the tail from the vehicle was placed in a comped tube via a Dorn fitting. As a one off this worked fine.

7.2.6.3. Jetway

During the mobilisation the JPT4 was installed in the deck lab. From here the JPT4 input and output cables were routed into the jetway container compartment where power was connected up along with the control cable. The control cable incorporates 3 normally closed stops and an emergency shunt stop. The emergency shunt stop has been installed near the engineers' chair and when used trips the main breaker of the JPT4. The N/C stops are in series with one another. The circuit for N/C stops include the ground fault monitor, the HV junction box safety switch and the JPT4 output fused junction box safety switch. The N/C stops work on the bases that if either one is open circuit the JPT4 unit will not turn on. The emergency stop is slightly different because it is a shunt, therefore if the circuit is closed the JPT4 will not turn on.

This cruise will be the first time the JPT4 will be tested underload and be in continuous operation for long periods of time. To achieve the desired voltage an external potentiometer located on the units side is used. Due to the potentiometer being located outside of the control container, power up of the JPT4 required two people, communicating with one another via radio. One person needed to turn on the power to the JPT4 and wind up the voltage, while the other team member needed to turn on the ground fault monitor and monitor the voltage on the engineer's GUI. The JPT4 unit has powered the ROV for 17 dives with dive times varying. For the first two dives the unit's voltage was not stable while underload. The output voltage would drop to around 89V which limited the power subsea. After some fault finding and reading of the units manual it was found that the unit would have voltage regulation under load but only in the automatic setting. The toggle switch located on the regulation PCB was therefore switched from manual to auto mode. Since then, the unit's voltage has been stable at 94V/95A output topside which gives a stable 238V no load and 200V under load subsea.

The next phase in the frequency converter upgrade is to remove the old jetway and install the new JPT4 unit in its place. The aim is to complete this phase post JC241. The JPT2 will need to be removed along with the 110V fused junction box. This junction box will need to be replaced with a smaller version or relocated. A new control box will also need to be designed and integrated into the control container, preferably located where the old control box is currently housed. The new control box will incorporate a HMI screen controlled via Canbus along with control buttons and an emergency stop. It will also require a switch that will turn the AC or DC voltage on but not simultaneously.

From listening to the JPT4 unit, a lot of the noise is created by the cooling fans. It was suggested that this noise could be overcome by swapping out the fans for silent running fans. This would reduce the noise that filters into the control van when the unit is running.

During the cruise the clear comms unit in the control van was producing a high-pitched tone when turned on. This high-pitched tone was then heard in the JPT4 unit when the ships 415V supply was turned on. It was then noticed that the input voltage to the JPT4 was reading 420V per phase. After 10 minutes it dropped to 410V per phase. The ships 415V supply doesn't seem to be well regulated and is fluctuating considerably throughout the day. This could be a potential issue for the frequency converter and also for the DC components on ISIS. If overvoltage occurs bottom side due to a spike in the topside voltage this would have the potential to damage electronic equipment on the vehicle. It has therefore been decided to only wind the voltage on the JPT4 unit up to only 90V.

7.2.6.4. Monitors

After 2 of them failing, the old monitors on the front bench have been replaced with the new Dell P2222H monitors before the expedition. Monitors have worked well for the duration of the expedition.

Second OFOP screen on the Science bench has very low resolution and flickering image due to semi-faulty ethernet VGA extender.

7.2.6.5. Clearcomm

Belt pack units with single ear headsets have been used during the launch and recoveries. This has worked well.

During the launch and recoveries, bridge is patched in to the comms via “Link On” button on the Clearcomm panel in the control van.

On Dive 383, one of the belt pack units (FSBP 3 / Serial # 12275) failed to establish connection with the main unit. This was due to its pre-assigned channel being already taken by another unit. Each unit has now been labelled with their channel numbers to be selected during the power-up to avoid such issues in the future.

On several occasions, bridge channel of the Clearcomm suffered noise on the line. As this only affected the bridge channel, and came on/went off with the Jetway turning on/off, the cause is thought to be the ethernet line going from Clearcomm unit through Jetway compartment, gooseneck to the JB12 in the hangar.

On pre-dive 390, the cable was rerouted to go through the hangar directly to the JB12. The noise was still present when the external jetway was turned on, only on the unit break (not even dialled up), so it is now not clear how the cable is still affected even though it is not going through the jetway compartment. It is though it may be an issue with an interference signal (eg, when the tunnel thruster is turned on or an equipment on the bridge). Most of the time, during launch and recoveries, the noise is not present and could be due by having a “load” on the system, eg: one of the wireless headsets is turned on and enabled. Will recommended to add a low pass filter as per Clearcoms guidelines.

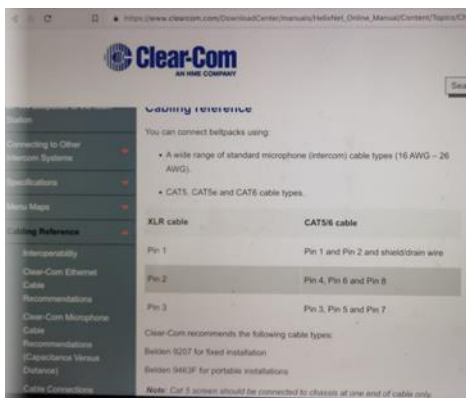

Fig. 7.114 Photo of Clearcomm pinout for the XLR connector and Ethernet cable:

7.2.6.6. New HP Prodesk 400 mini PCs

Several units were fitted to replace the old HP G5 that have been working for the last 8 years on the Control Van. They have performed well, with no issues related to software problems, as well as reducing the noise and heat dissipation.

7.2.6.7. HP G5/G6 Computers

Only Techsas and Topside are running on the EOL G5 Computers. Both HP G6 that had Ranger 2 and Database have been replaced with new computers.

Some machines have been serviced and fitted as spares on the sound rack in the Control Container #2.

They act as potential spares for the Topside, Techsas. Just in case, a spare G6 unit is also available as a spare for the old Database or the Ranger 2.

7.2.6.8. Topside PC

Performed correctly. Still using old HP G5 machines.

7.2.6.9. Database PC

On dive 390, the overlay was not working properly. Time/date was correctly refreshing, but not the heading which was frozen/static. The Logbook software was then closed (using Main Menu -> Exit). When the

software was restarted, it did not recover the previous status (the In Water button had been pressed since the ROV was descending to the bottom). To solve the issue, on the MISSION menu, the database name was changed to JC237b and the last dive number was set to 389, so when a new dive was created, it would be the 390.

TBC: Note that when the logbook completely crashes, it does recover to the previous status since it has a text file to read the most recent button pressed. If the above case happens again, use a “kill -9 xxx” console command instead of closing the software through its menu.

7.2.6.9.1 Overlay Data Display

This unit was used with the Science camera.

No issues reported.

7.2.6.10. OFOP Science PC

The OFOP license was extended for a further five years and a spare dongle has been procured. After liaising with the developer (Geomar), a new version has been installed. It now shows a warning message for science to “change tape now” when the 2 hour timer trigger.

No issues reported.

7.2.6.11. CLAM PC

Continued use of the new version of CLAM developed by Josue was used.

No issues reported.

7.2.6.12. Device Controller PC

The Arduino pressure, temperature and humidity data was read using HyperTerminal. See section 7.2.5.3 for more details.

7.2.6.13. Sonardyne PC

The new Steatite rack computer to replace the old HP G6 was used on this cruise.

During the wire stream, ROV C5(Address 210) and umbilical G6 WMT (Address 2709) refresh rate was seen to be slow on the Ranger2 software. This had improved after the changes been made in the beacon settings. The beacons were set to CIS, which was causing them to take time/clash in responding as the interrogation was made collectively. This setting was then changed to IIS, which makes individual interrogation. Power settings of the beacons were also changed to maximum as deep dives were planned later in the expedition. These new settings have made a big improvement in response times and the beacons have performed well for the duration of the expedition.

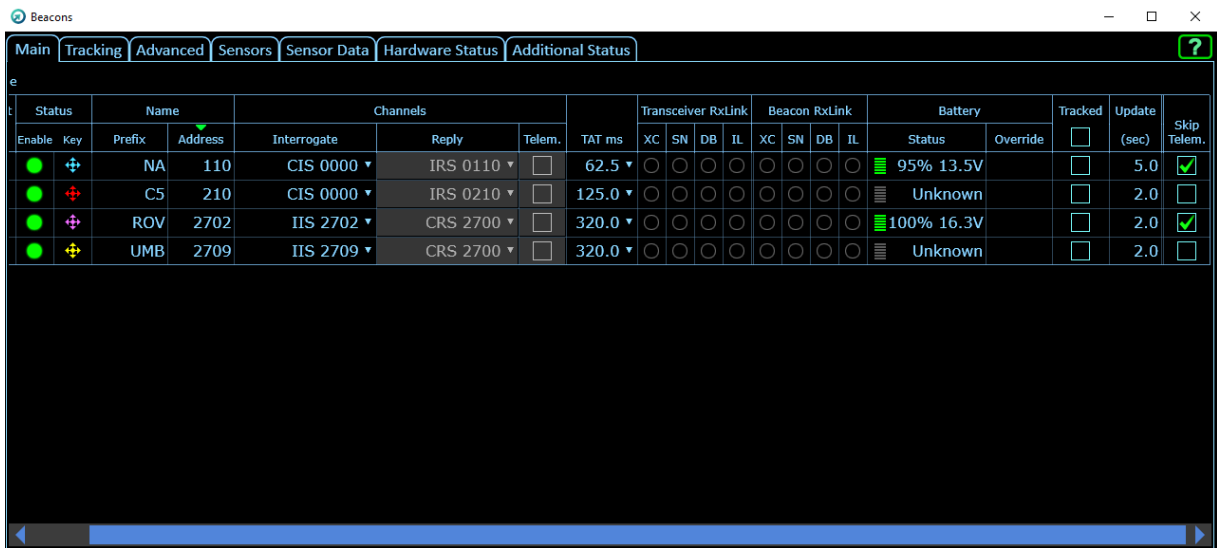

Fig. 7.115 Screenshot of the Sonardyne GUI

On Dive 391, at 200m depth, the ROV Beacon 2702 was not refreshing continuously, only around every 20 seconds, while the Umbilical was working fine. This had been noticed during some of the other dives. At 1100m, the ROV Beacon stopped reporting its position during more than 300 seconds and did not recover. The settings were then changed back to the original settings of using CIS, with a “update” seconds of 2 for the ROV and 5 for the Umbilical. This fixed the issue of the ROV beacon not talking and we got constant pinging without issues. This will be checked for the rest of the cruise, it may be the beacon needs servicing/replacement.

Ship Systems have replaced the Avocent units with new Blackbox units. This forced to change the Ranger 2 video output from VGA to DVI. After some changes and several iterations, it was possible to run it with VGA fro the ROV KVM, HDMI to DVI for the front row monitor and DP to DVI for the Blackbox.

The ROV Ranger 2 software version is “4.06.02.5802”. This was not upgraded to the latest version after the head upgrade made by Sonardyne on both ships to support the Robotics package. The latest version of Ranger 2 (Version 6.03.06.7270) installed on the ships drop the support of the Wideband of the 5G generation. This forces to use the older beacons, eg C5, on HPR mode which has less bandwidth and precision.

7.2.6.14. Techsas

Techsas 5.11 running on CentOS7 VM is being tested, running in parallel with the old Techsas on G5 for the duration of the expedition. During the mob, the new Dell R340 server failed to bootup. A different power supply did not solve the problem, and its own power supply proved to be working after testing on a different server. After the failure of new Dell R340, an old Dell 610 server had been installed in the CV2 and Techsas 5.11 is setup for testing. A bug on a utility that Techsas software contains is causing a glitch, which results in a blank Techsas window after changing to a different screen than VM. This seem to not affect the data acquisition of Techsas. However, data is to be compared to the one from the old Techsas after the expedition. Further testing is required before commissioning the new Techsas server and VM.

Old Techsas on G5 has worked fine for the duration of the expedition.

7.2.6.15. **QNAP**

The QNAP has proven to be a good upgraded of the old EOL X-Serve. This provides direct access to all the ROV data as well as a webpage developed for Science to access guides, templates and datasheets related to Isis.

7.2.6.16. **Ki Pro Recorders**

Worked correctly. The AJA Ki Pro rack units only support 1080 interpolated resolution, while our cameras are able to output 1080 progressive resolution.

7.2.6.17. **iMacs**

Science used the iMac with the Final Cut Pro software to access the video and data stored on the Lacie units. A hard drive was made available for science to copy data from the iMac to their computers.

7.2.6.18. **Focal (telemetry upgrade)**

JC237 is therefore the first expedition with the new Focal system, and has performed successfully without issues throughout the cruise.

See Appendix D for more detail about the system.

7.2.6.19. **Joybox**

Joybox #4 was used throughout the cruise.

Joybox #3 was repaired and fitted with a new Z vertical joystick. The joystick used is a less tension compared to the originally supplied by WHOI. This was done to test if this will reduce the fatigue experienced by the pilot after several hours of continuous use.

On the last dive Joybox #3 was used to test if it made a big difference the lighter spring version of the joystick.

7.2.6.20. **Network Time Protocol (NTP) Server**

This unit performed correctly. No more loosing lock issues have aroused after the firmware upgrade done after talking with the manufacturer prior to this cruise.

7.2.6.21. **Colour bar generator**

The PAL colour bar generator worked correctly with the new power supply fitted prior to the cruise.

7.2.6.22. **Raspberry Pi TV Changer**

A Raspberry Pi was installed in the Control Van. It was fitted with a pushbutton that allowed the Engineer to quickly change the TV from PC mode to HDMI. This allows to get a better display of the Pilot HD camera.

7.2.6.23. **4K HDMI Splitter**

Unit worked correctly – power unit failed, and was replaced with spare

7.2.6.24. **ROV video streaming**

Blackmagic ATEM Mini Pro and a Raspberry Pi 4 was used to stream the ROV video to the lab. This setup provided the flexibility to instantly display different cameras in the lab on scientists' request. The system has worked well for the duration of the expedition.

ATEM Mini Pro was also used to live stream 3 ROV dives at PAP to the scientists ashore via Microsoft Teams. Scientists ashore and aboard the vessel were able to communicate via MS Teams chat. Live streaming was successful. ATEM Mini Pro handled both live streaming simultaneously to the shore and to the main lab aboard the vessel successfully.

7.2.7. Isis ROV Dive Summary

No. of dives JC237	17 (Dive nos. 382 to Dive no. 398)
Total run time for (JC237) thrusters:	242.83 hrs
Total time at seabed or survey depth:	184.53hrs
Isis ROV <i>total</i> run time:	5244.17hrs
Max Depth and Dive Duration:	4843 m and 10.78hrs (Dive 395) (17.5hrs in water)
Max Dive Duration and Depth:	13.37hrs at m (Dive 393) (15.06hrs in water)
Shallowest Depth and Duration	334m for 2.05hrs (Dive 382) (3.62 hrs in water)

Recorded Data:

Video (38.3 TB)	DVLNAV (47.08 GB)
Techsas (10.03 GB)	CTD (331.8 MB)
OFOP Event Logger (1.22 GB)	Sonardyne (6.08GB)
Scorpio Digital Still (23.845 files, 91.77 GB)	Reson Seabat (48.65 GB)

Master #1 Lacie Raid unit SER# NL6N05GR will be installed in the NOC media room for BODC to archive and provide access for scientists post cruise.

Backup #1 Lacie Raid unit SER# NL6N05GN will be retained by the ROV team until BODC have archived the Master unit

JC237									
1	382	3.617	03:37:00			334	02:03:00	2.05	
2	383	13.417	13:25:00			1079	11:20:00	11.33	
3	384	14.000	14:00:00			1101	11:37:00	11.62	
4	385	15.033	15:02:00			1404	11:58:00	11.97	
5	386	15.867	15:52:00			1532	09:31:00	9.52	
6	387	15.033	15:02:00			1532	13:20:00	13.33	
7	388	14.717	14:43:00			1532	11:58:00	11.97	
8	389	14.167	14:10:00			1339	11:39:00	11.65	
9	390	14.967	14:58:00			1958	12:04:00	12.07	
10	391	13.617	13:37:00			1958	10:46:00	10.77	
11	392	12.217	12:13:00			1959	08:47:00	8.78	
12	393	15.067	15:04:00			710	13:22:00	13.37	
13	394	14.033	14:02:00			479	12:13:00	12.22	
14	395	17.500	17:30:00			4843	10:47:00	10.78	
15	396	18.017	18:01:00			4837	11:57:00	11.95	
16	397	15.567	15:34:00			4841	09:26:00	9.43	
17	398	16.000	16:00:01			3205	11:44:00	11.73	
JC237 Totals	17	242.834	242:50:01	242.83	5244.17	4843	172:28:00	184.533	

7.2.8. ISIS Dive metadata

For each ISIS dive, metadata, recorded by the TECHSAS system, are stored in various formats. This includes NetCDF, but also ASCII .csv files. Normally, the most useful of those are the files in the ISCSV folder. The columns for those contain the following data:

Field Name Units

- Vehicle identifier \$ISMES
- Date DD/MM/YY
- Time hh:mm:ss.ddd
- File identifier ISCSV
- Flag
- Year
- Month
- Day
- Time, hour
- Time mins
- Time, secs
- Latitude deg
- Longitude deg
- csvX m
- csvY m
- Lat Origin deg
- Lon Origin deg
- Xutm m
- Yutm m
- UTM Zone
- Depth m (Isis Parascientific Digiquartz Pressure Sensor)
- Altitude m (Isis Kongsberg Altimeter)
- Heading deg (Isis Octans, MRU)
- Octans Pitch deg
- Octans Roll deg
- Xbw Head deg (Isis Crossbow compass)
- Xbw Pitch deg
- Xbw Roll deg
- Wraps Number of turn in Isis umbilical

Unfortunately, an error was made with the reference latitude & longitude, and the coordinates in these ICSV files are not correct. The correct coordinates can be found in the IGGA folders (USBL coordinates) and CSVGA folders (Doppler navigation coordinates).

Alternatively, positional data is also recorded by the Science OFOP system (which also allows annotation of the dive in real time). These files are easier to import into GIS systems, and do contain the correct navigation. However, the times in the OFOP files are rounded to the second, while the native TECHSAS files contain higher resolution information (time in seconds provided to 3 decimal places). Hence, for some applications (e.g. ROV multibeam processing), it may be necessary to go back to the TECHSAS files.

In addition, throughout the cruise, the altimeter had problems, and no altimeter data was recorded. However, altitude data from the Doppler ADCP was recorded in the CSVGA files, and in the OFOP files.

7.2.9. ROV Vehicle Specification

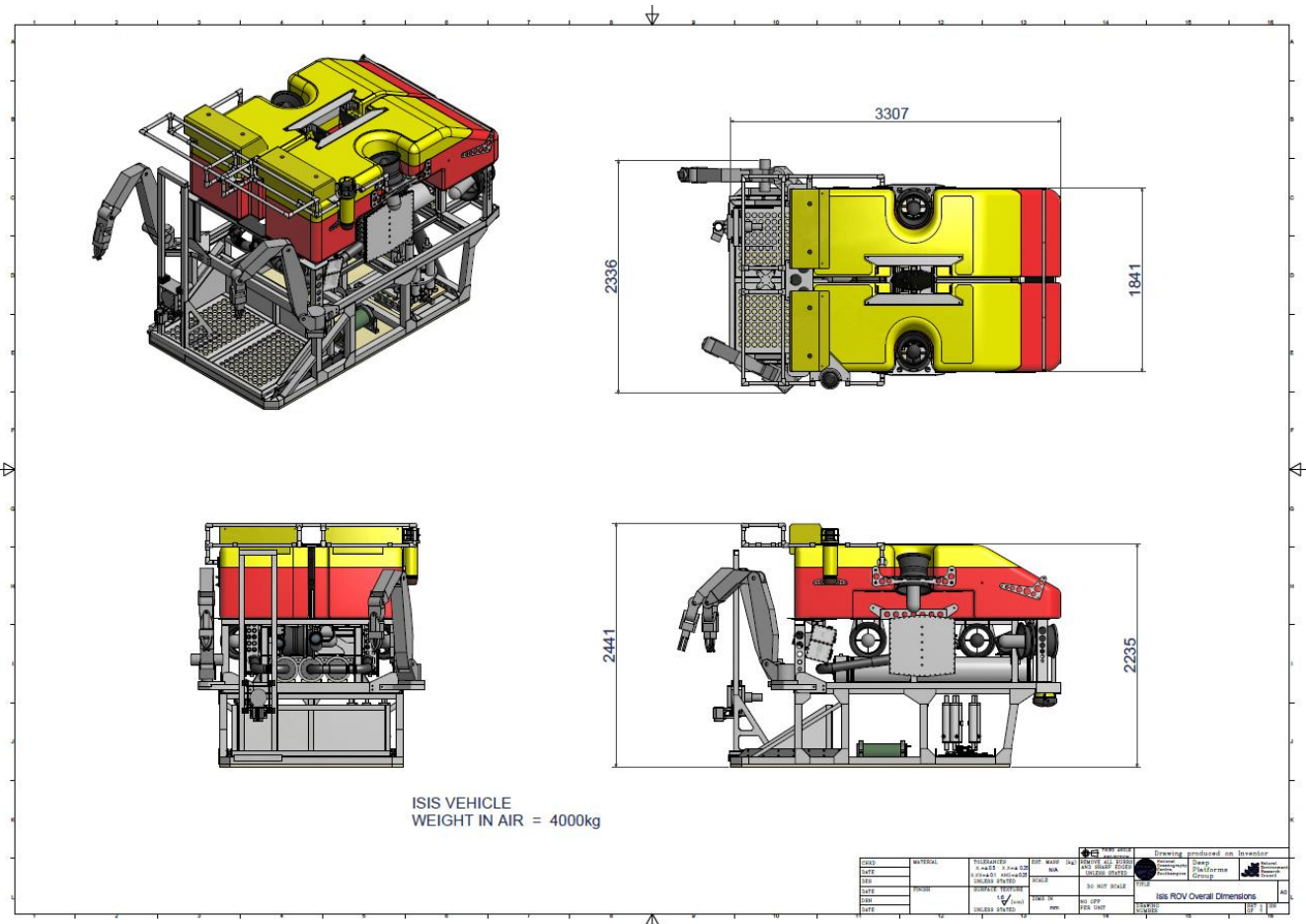

Maximum Operating Depth	6500m
Size	3.3m (L) x 2.3m (W) x 2.4m (H)
Weight	In air: ~3750kg In water: neutrally buoyant
Payload	up to 90kg (in water weight)
Propulsion	6 x 5HP Brushless DC Electric Thrusters (113 kg force/motor)
Umbilical	Rochester 0.68" (17.4mm dia) 3 core triple armoured 3 fibre single mode (Part No.A302351)
Electrical Power	Pmax: ~18kW at 6500m (2800V@ 400Hz)
Hydraulic Power	1 x 3.7Kw (5HP) HPU Max pressure 3000psi (207bar) Max Flow 21L/min @ <1700psi Max Flow 12.5L/min @ > 1700psi 8 Function Manifold
Max Vehicle Speed	Fwd: 1.5 knot, Lateral: 0.5 knot, Vertical: 0.7knot
Max on Bottom Transit Speed	0.5 knot
Descent/Ascent Rate	40m/min
Auto Functions	Depth (+/-1m), Altitude (+/-1m), Heading (<=+/-1°)
Manipulators	1 x Schilling Titan 4 (7 function) 1 x Kraft Predator (7 function with force feedback)

7.3. Coring Technical Report

Operational Team: Richard Phipps, with help from Brian Bett

7.3.1. Gravity corer

The OEG gravity corer used during this cruise weighs 0.4T and at present can only be used with a maximum 3m core barrel due to the bomb weight being insufficient to allow the corer to be deployed horizontally. (The weight of a 6m barrel would make the device nose heavy) However, I don't think we would have risked a 6m barrel in the Whittard Canyon.

Being able to see the seabed via the ROV cameras was a huge advantage and meant I was able to adjust the speed at which the corer hit the bottom accordingly.

Due to the very sandy bottom with little or no sediment in most core sites, the coring winch drove the corer into the bottom at 80m/min.

This is unusually fast, but meant the corer usually recovered something, even if it were only a few centimeters deep.

I feel a heavier weight on the corer head would have been advantageous and where there was plenty of sediment, I could have adjusted the winch speed accordingly to prevent over penetration.

I have mentioned this to OEG management and suggested that we consider having larger weights cast for this corer.



Fig. 7. 116 Gravity corer coming back on board

7.3.2. Megacorer

Due to its comparatively fragile nature and the hostile terrain in Whittard Canyon, the Mega Corer was only deployed after it was established that there was plenty of sediment at the various sites by taking a gravity core first. As a consequence, the corer worked well with no damage during deployment.

Some acrylic core tubes were damaged while removing previously frozen cores, due to the acrylic becoming brittle at such low temperatures. Typical bottom operations would involve stopping the winch approximately 50 m above the sea-bed and allow the corer to settle for two minutes. Then lower into the sea-bed at 10 m/min and continue to veer for an additional 5 m after the winch load cell indicates that the corer is on the bottom. The corer was then allowed a further 1 minute on the seabed before hauling in at 10m/min. Once the corer was well clear of the sea-bed the winch was brought up to 40 or 50 m/min.

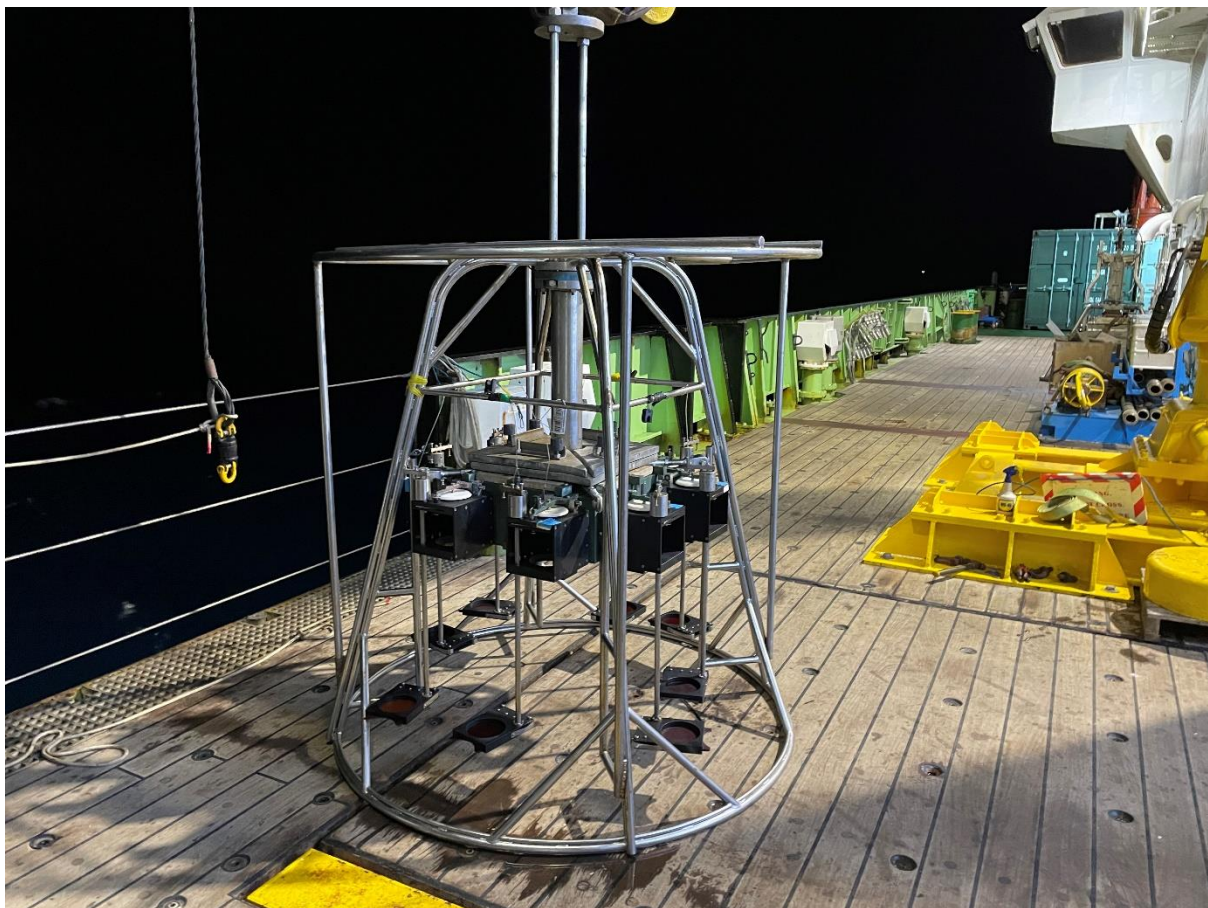

Fig. 7. 117 Megacore frame

7.4. CTD

Operational Team: Dougal Mountifield

7.4.1. CTD Summary

The JC237 CTD work was in support of a benthic habitat survey of the Whittard Canyon system. A Stand-Alone Pump (SAP) was fitted to the CTD frame to provide an opportunity to obtain in-situ filter samples during 5 casts. There were also additional opportunistic CTD deployments for physics including a 13-hour tidal yo-yo survey.

21 CTD casts were undertaken with an NMF 24-way Stainless Steel CTD frame with 24 of 10l OTE water samplers. A single SBE 43 dissolved oxygen sensor was used on the primary channel. The primary temperature, conductivity and dissolved oxygen sensors were mounted to the 9plus within the CTD frame. The secondary temperature and conductivity sensors were mounted on the vane.

The SAP was attached to a new design bottle mount assembly and was fitted in bottle position 3. Adjacent bottles 2 and 4 were removed to provide sufficient space. The SAP was removed for the yo-yo survey with bottles 2, 3 & 4 refitted for the tidal survey.

The WETLabs BBrtD sensor was mounted in a horizontal orientation on the vane. A pair of TRDI Workhorse 300kHz LADCPs were used in a down-looking master, up-looking secondary configuration powered by an NMF LADCP battery pack with a titanium housing.

The ODIM winch system Active Heave Compensation (AHC) system on CTD2 had issues with compensator oscillation which caused concerning vibration. The AHC system was therefore not used during JC237.

The deepest cast was CTD001 at station 02 which descended to 4031m. The shallowest cast was CTD002 at station 08 which descended to 407m.

7.4.1.1. Stainless Steel CTD Configuration

7.4.1.1.1 Instrument Package

Table 7.106 sensors installed on the CTD frame

CTD Underwater Unit	Seabird SBE 9plus	09p-0803
Primary Temperature Sensor	Seabird SBE 3P	3p-2729
Primary Conductivity Sensor	Seabird SBE 4C	4c-2858
Pressure sensor	Parascientific Digiquartz	93896
Secondary Temperature Sensor	Seabird SBE 3P	3p-4814
Secondary Conductivity Sensor	Seabird SBE 4C	4c-3054
Primary Pump	Seabird SBE 5T	05-7516
Secondary Pump	Seabird SBE 5T	05-7517
Primary Dissolved Oxygen Sensor	Seabird SBE 43	43-2575
Altimeter	Valeport VA500	81632
Back Scattering Sensor	WETLabs BBrtD	759R
Transmissometer	WET Labs C-Star	2150DR
Fluorimeter	CTG Aquatracka MKIII	88-2615-126
PAR Down-looking UWIRR	Biospherical QCP-2350-HP	70520
PAR Up-looking DWIRR	Biospherical QCP-2350-HP	70510
Down-looking Master LADCP	TRDI Workhorse 300kHz	12369
Up-looking Secondary LADCP	TRDI Workhorse 300kHz	4275

The 'secondary' vane-mounted sensors usually produce cleaner measurements. They are sited in a flow of cleaner quality because they are less subject to package wake effects. The 'primary' frame-mounted sensors are usually subject to greater package wake effects and should be considered of secondary quality. It is possible that the reverse is the case during bottle stops where the vane usually settles downstream of the main frame.

For clarity, the terms primary and secondary do not normally refer to the absolute accuracy, stability, or noise of the sensors themselves, although it could if the sensors were selected specifically for these properties.

A few years ago, the WETLabs BBrtD backscatter sensor was relocated from a down-looking orientation within the CTD frame to a side-looking orientation on the CTD vane to site it in cleaner water-flow. The rationale was to improve the signal to noise ratio and reduce offset between down-cast and up-cast that has been observed in the past. The centre of the BBrtD face was located **0.77m above the pressure sensor**.



Fig. 7.118 WETLabs BBrtD Backscatter Sensor Mounting Location

The down-looking TRDI Workhorse LADCP was located at the centre of the CTD frame. The up-looking unit was mounted within an out-rigger sub-frame on the opposite side of the CTD frame to the vane.

All instrument serial numbers and all channels of the 9plus underwater unit checked prior to completing the Sensor Information Sheets for JC237

7.4.1.1.2 SBE 9plus CTD Top End Cap Configuration

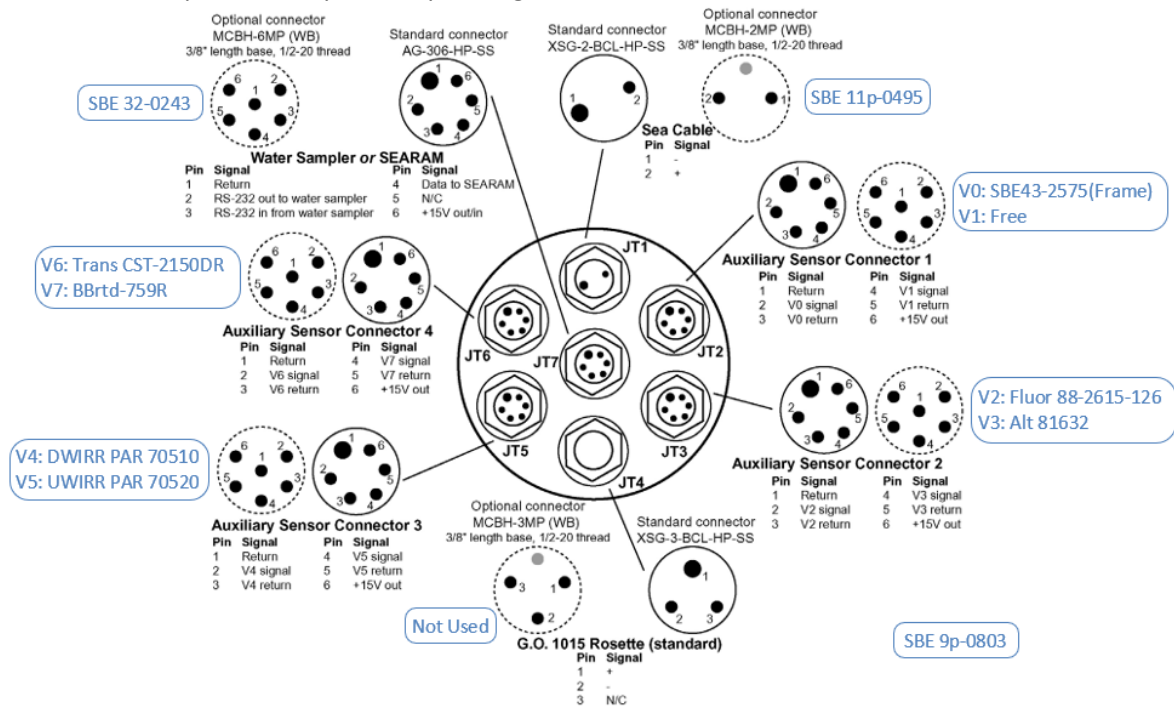

Fig. 7.119 CTD top end cap configuration

7.4.1.1.3 SBE 9plus CTD Bottom End Cap Configuration

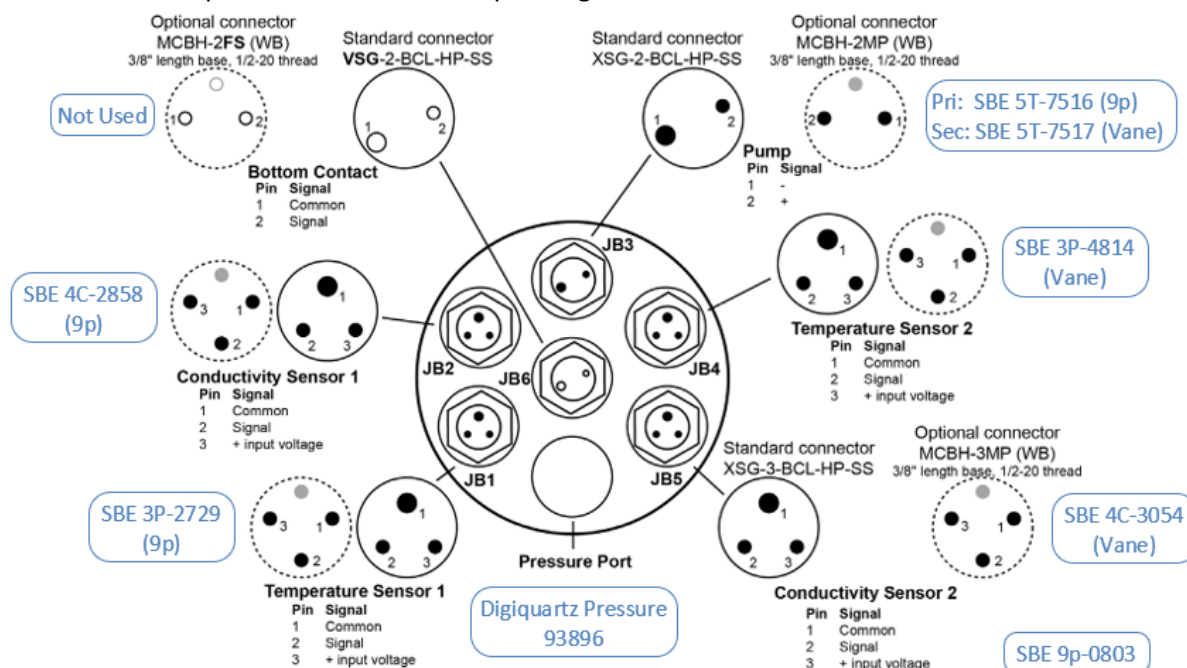

Fig. 7.120 CTD bottom end cap configuration

7.4.1.2. Seasave Configuration & Instrument Calibrations

The Seasave Instrument Configuration file used for all casts was JC237_0803_SS_nmea.xmlcon

Date: 09/04/2022

Instrument configuration file: C:\Users\sandm\Documents\Cruises\JC237\Data\Seasave Setup Files\JC237_0803_SS_nmea.xmlcon

Configuration report for SBE 911plus/917plus CTD

```

-----
Frequency channels suppressed : 0
Voltage words suppressed      : 0
Computer interface            : RS-232C
Deck unit                     : SBE11plus Firmware Version >= 5.0
Scans to average              : 1
NMEA position data added      : Yes
NMEA depth data added         : No
NMEA time added               : No
NMEA device connected to     : PC
Surface PAR voltage added     : No
Scan time added               : Yes
  
```

1) Frequency 0, Temperature

Serial number : 03P-2729
Calibrated on : 28 April 2021
G : 4.35500409e-003
H : 6.41383712e-004
I : 2.30182565e-005
J : 2.18587894e-006
F0 : 1000.000
Slope : 1.00000000
Offset : 0.0000

2) Frequency 1, Conductivity

Serial number : 04C-2858
Calibrated on : 13 August 2020
G : -1.02345407e+001
H : 1.43849461e+000
I : 5.45418632e-004
J : 3.74711409e-005
CTcor : 3.2500e-006
CPcor : -9.57000000e-008
Slope : 1.00000000
Offset : 0.00000

3) Frequency 2, Pressure, Digiquartz with TC

Serial number : 93896
Calibrated on : 12 November 2020
C1 : -8.331332e+004
C2 : -3.281962e-001
C3 : 2.216060e-002
D1 : 2.906000e-002
D2 : 0.000000e+000
T1 : 3.005232e+001
T2 : -3.843669e-004
T3 : 4.436390e-006
T4 : 0.000000e+000
T5 : 0.000000e+000
Slope : 1.00005000
Offset : -2.68480
AD590M : 1.289250e-002
AD590B : -8.106440e+000

4) Frequency 3, Temperature, 2

Serial number : 03P-4814
Calibrated on : 28 April 2021
G : 4.30087112e-003
H : 6.24277868e-004
I : 1.83296789e-005
J : 1.23535239e-006
F0 : 1000.000

Slope : 1.00000000
Offset : 0.0000

5) Frequency 4, Conductivity, 2

Serial number : 04C-3054
Calibrated on : 28 April 2021
G : -9.80228664e+000
H : 1.42049812e+000
I : 2.65690865e-004
J : 6.44135237e-005
CTcor : 3.2500e-006
CPcor : -9.57000000e-008
Slope : 1.00000000
Offset : 0.00000

6) A/D voltage 0, Oxygen, SBE 43

Serial number : 43-2575
Calibrated on : 28 April 2021
Equation : Sea-Bird
Soc : 4.33300e-001
Offset : -4.60300e-001
A : -4.69600e-003
B : 2.02790e-004
C : -2.46080e-006
E : 3.60000e-002
Tau20 : 1.22000e+000
D1 : 1.92634e-004
D2 : -4.64803e-002
H1 : -3.30000e-002
H2 : 5.00000e+003
H3 : 1.45000e+003

7) A/D voltage 1, Free

8) A/D voltage 2, Fluorometer, Chelsea Aqua 3

Serial number : 88-2615-126
Calibrated on : 17 November 2020
VB : 0.260123
V1 : 1.975280
Vacetone : 0.783490
Scale factor : 1.000000
Slope : 1.000000
Offset : 0.000000

9) A/D voltage 3, Altimeter

Serial number : 81632
Calibrated on : 9 June 2022

Scale factor : 15.000
Offset : 0.000

10) A/D voltage 4, PAR/Irradiance, Biospherical/Licor

Serial number : 70510
Calibrated on : 13 August 2021
M : 1.00000000
B : 0.00000000
Calibration constant : 16666670000.00000000
Conversion units : umol photons/m²/sec
Multiplier : 1.00000000
Offset : -0.06110141

11) A/D voltage 5, PAR/Irradiance, Biospherical/Licor, 2

Serial number : 70520
Calibrated on : 13 August 2021
M : 1.00000000
B : 0.00000000
Calibration constant : 15384620000.00000000
Conversion units : umol photons/m²/sec
Multiplier : 1.00000000
Offset : -0.06666738

12) A/D voltage 6, Transmissometer, WET Labs C-Star

Serial number : CST-2150DR
Calibrated on : 17 Sept 2021
M : 21.4869
B : -0.1311
Path length : 0.250

13) A/D voltage 7, OBS, WET Labs, ECO-BB

Serial number : 759R
Calibrated on : 10 December 2019
ScaleFactor : 0.003806
Dark output : 0.040600

Scan length : 41

7.4.1.3. Stainless Steel CTD Frame Geometry

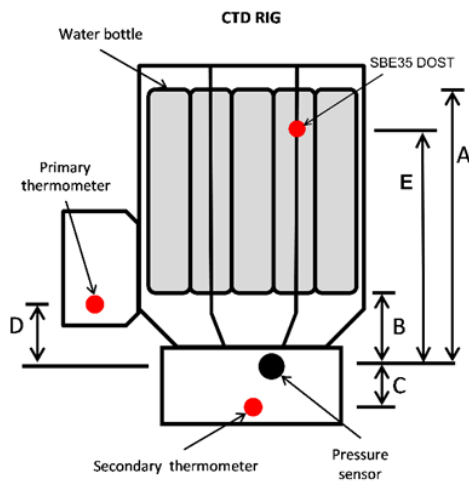

ID	Vertical distance from pressure sensor (m positive-up)
A	1.2 (Top of water samplers)
B	0.34 (Bottom of water samplers)
C	-0.075 (<i>Primary T mounted on 9p</i>)
D	0.085 (<i>Secondary T mounted on Vane</i>)
E	SBE35 DOST not fitted

Fig. 7.121 CTD Frame lay-out

7.4.1.4. CTD Operations

7.4.1.4.1 CTD Deployment Method

The CTD was operated out of the Water Sampling Laboratory at the forward end of the hangar. It was deployed on the 11.43mm conducting CTD wire (CTD2 storage drum) using the hydro-boom.

To provide shelter to the science party whilst sampling, the CTD was transferred to the water-sampling laboratory using the hydro-boom once inboard. This also allowed quick changeover between CTD and coring work.

A normal operating range of 10m from seabed for the CTD package was used at the end of the down-cast and the winch operator was notified of the maximum wire-out. During stations with steep bottom topography or otherwise lower acoustic reflectivity, the time spent finding the bottom was extended. Shorter veer calls were issued at slower wire speeds to provide additional safety margin. When there was a strong current, and the vessel was moving over the ground, the proximity to the bottom at the end of the downcast was increased for similar reasons. The proximity to the bottom was increased to 30-50m when in close proximity to very steep topography and to 100m when operating within 40-50m of the ~100m high vertical wall in one of the canyons.

7.4.1.4.2 Use of WMT USBL Beacon

From CTD004 onwards, a Sonardyne WMT USBL Beacon (unit 42F3, transponder code 2212) was fitted to the CTD frame on a vertical stanchion. The unit was located such that the transducer was above the tops of the rosette bottles. The use of USBL on the CTD and DP allowed accurate positioning of the CTD package when working in some of the more 'interesting' canyon features. It was possible for the OOW to keep the CTD beacon within 20m of the waypoint even throughout the ~3hr SAP casts. It was not necessary to recharge the beacon battery during the cruise.

7.4.1.4.3 First use of new-build MDS EM Swivel 1267-1

A fifth new-build NMF MDS EM swivel s/n: 1267-1 was deployed for the first time since manufacture. The first cast was to 4000m with no problems. The swivel was frequently inspected throughout the

cruise to check for oil egress, but none was observed. A spare EM swivel was available onboard. The CTD wire and swivel were frequently insulation tested after disconnecting the sea-cable extension from the swivel. The CTD wire and electrical splice maintained an insulation resistance of >999MΩ at 500V throughout the cruise.

7.4.1.4.4 CTD Sensor Cleaning Protocol

During the mobilisation, both TC ducts were cleaned with Triton-X and dilute bleach solutions agitated with a syringe. The TC ducts were thoroughly flushed with Milli-Q after each cleaning solution. All optical instruments (PARs, Fluorimeter, Transmissometer, BBrtD) were rinsed with MilliQ, squirted with Triton-X solution, dried with Kimwipes, then polished with Optic Prep wipes.

Between casts the TC & DO sensor pairs were flushed with Milli-Q three times and drained before installation of caps on the TC-duct inlet and pump exhaust of both sensor ducts.

The optical instrument faces were rinsed with MilliQ after recovery.

Between stations, the whole CTD package was rinsed with fresh water to prevent salt crystals forming on the sensors, associated tubing and particularly the carousel latch assembly. After fresh-water washing of the CTD, the optical instrument faces were once again rinsed with MilliQ.

The TC-ducts were not cleaned with Triton-X or bleach solutions during the cruise unless fouling was observed. There was one sensor fouling event during the cruise. After this fouling event both CTD ducts were syringe-cleaned with both bleach and Triton-X solutions and well flushed with MilliQ.

The sensor fouling event occurred early (~100m) in the downcast of CTD021 when the primary salinity briefly spiked low, then suffered a negative offset throughout the cast. Initially the offset was ~0.030 low in salinity, but quickly increased to ~0.045 low in salinity. This offset continued to be stable throughout the rest of the cast. The secondary temperature and conductivity measurements were not affected. 8 discrete salinity samples were taken during CTD021, and a separate set of regressions and adjustments were created for the primary salinity during CTD021. The salinometry analysis established the offset to be stable at -0.045 (low) in salinity.

All discrete salinity samples were taken and analysed by the NMF Sensors & Moorings Technician.

7.4.1.5. CTD Performance, Technical Issues & Instrument Changes

There were no major technical issues with the CTD suite during the cruise and no scientific instruments required changing for spares. There was no noticeable change in the differences indicated in Seasave between the primary and secondary sensors for temperature (<0.001 °C) and salinity (<0.003 PSU), during data acquisition. There was negligible drift in all SBE 3P and SBE 4C sensors throughout the cruise when comparing them to discrete bottle samples. A single SBE43 dissolved oxygen sensor was used, but the science party did not take any discrete oxygen samples. There was no significant drift in pre-deployment air saturation readings.

7.4.1.5.1 CTD Suite Spares Availability

Two full suites of spare instruments were available for use and a spare CTD frame was also available onboard.

The PAR sensors that were used were Biospherical Quantum QCP-2350-HP cosine units which have a depth rating of 10,000 m and were fitted throughout the cruise. The two sets of spare PAR sensors

available for use were CTG 2π hemispherical scalar units which have a significantly reduced depth rating of 500m.

7.4.1.5.2 CTD Wire Condition

A full drum of spare CTD wire was available on the CTD1 storage drum. CTD2 storage drum was used on the cruise.

A new set of sheaves has recently been fitted to the Hydroboom head and this has removed the ticking, pinging and graunching noise of the wire entering the root of the groove that was previously experienced.

CTD2 wire is quite greasy, but considerably less greasy than CTD1.

A spare CTD mechanical termination was available onboard. The Deep-tow wire was terminated during the JC238 mobilisation using the Sensors & Moorings Evergrip termination. Both the CTD1 and Deep Tow wires were load-tested, and functionally tested prior to use. The Deep Tow termination was not deployed on JC237 and remained in a serviceable condition at the end of the cruise.

7.4.1.5.3 Water Sampler and Carousel Maintenance

All the water sampler bottles were leak-tested during the mobilisation by filling with fresh water, seating the end caps, closing the vents, and opening the taps. Weeping or dripping taps thus indicated if the bottle has an air leak. All were good.

During the mobilisation, the carousel head latch assemblies on both CTD frames were removed, dismantled, and thoroughly cleaned. Then the head assembly was reassembled and refitted to the carousel.

The carousel latches were frequently rinsed with MilliQ and exercised to keep them free of salt accumulation.

At the end of the cruise all bottles were leak tested again after cleaning throughout with fresh water, and no leaks were observed.

7.4.1.6. CTD Topside Moxa NPort Serial Device Servers

Two Moxa 5210A NPort serial device servers were available for use in the CTD topside racks. These were installed by the NMF Sensors & Moorings Technician during JC238. Each NPort has two serial ports which are presented as standard RS-232 serial 9-way D-sub connectors.

Fixed IP addresses were allocated for the NPorts and added to the DNS as follows:

s/n: 690 - ctdmoxa1.cook.local was installed in SBE CTD Topside Rack 2A with IP address 192.168.62.103

s/n: 695 - ctdmoxa2.cook.local was installed in SBE CTD Topside Rack 2B with IP address 192.168.62.104

Both NPorts currently have firmware version 1.6 Build 20101317 installed.

7.4.1.7. CTD Cast Events

7.4.1.7.1 CTD AHC Issues

The intention was to use AHC (Active Heave Compensation) during the cruise. During CTD001, vibration and noise from the winch-room was heard as soon as AHC was enabled, and got worse as the veer started. The vibration and noise were found to be created by the excessive and rapid movement of the compensator damper. This indicates that the motion of the traction winch and storage drum are not matched.

AHC was tested again with a 500kg weight for further examination by the C/E and ETO. The problem persisted and AHC was not used again for the rest of the cruise.

7.4.1.7.2 Sealing of CTD1 wire bitter-end for AHC testing

Following the completion of CTD work after CTD021, the CTD termination was cut off CTD2 wire to allow a changeover to CTD1 for AHC testing. The bitter-end of CTD1 was sealed for 500kg weight test of AHC on CTD1. The bitter-end was sealed using a similar method to a normal CTD electrical splice, without the pigtail spliced on. The wire was continuity tested OK at 76 ohm (loop-back) and the bare wire insulation tested at >1000M at 500V. After thoroughly degreasing the wire, the inner armour was cut back leaving about 5" of PTFE insulation exposed. The copper core was cut flush with the PTFE insulation. The PTFE was abraded along its full length and cleaned with IPA. The end of the PTFE was abraded to create a soft radius at the bitter end. Scotch-kote was applied to the bitter end and about 1" up the insulation and also at from the armour and about 1" of insulation at the other end (i.e. about 2-3" of PTFE insulation with no Scotch-kote). Cross lays of amalgamating tape over the bitter end were alternated with wraps around the insulation. 4 layers of amalgamating tape were used with Scotch-kote in between. Finally 2 layers of Super-33 were used followed by a heat-shrink over-jacket. After sealing the end, the wire was again insulation tested OK at >1000M at 500V. The CTD1 wire was then mechanically terminated using a thimble and 4 bulldog clamps, followed by another successful insulation test.

7.4.1.7.3 Test of CTD1 wire for AHC test

200m of wire was deployed during the 500kg AHC weight test of CTD1. The wire was insulation tested, first after taking the load on deck, then upon entering the water. All insulation readings were >1000M at 500V. When AHC was turned on at 200m wire out, the same problem occurred with rapid oscillation of the compensator. Therefore AHC is not currently possible for CTD use. The CTD1 wire was insulation tested throughout the trial, through the haul and after recovery to deck. Once again, all insulation test readings were >1000M at 500V.

The bulldog termination and sealed end were left on the CTD1 wire at the end of the cruise for testing after the anticipated rectification work to the AHC system.

7.4.1.8. CTD Cast Summary

21 casts were completed during JC237 including a 13 hr tidal survey yo-yo in a canyon.

The yo-yo comprised of 7 'profile only' casts followed by a final cast with bottles fired. The first cast of the yo-yo was between the surface and 50m above bottom (to allow LADCP bottom tracking during processing). The final cast of the yo-yo started by lifting the package up to deck level to confirm that all the bottles had remained cocked, and then was essentially a normal CTD cast with bottles. The intermediate casts were between 50m below the surface (to save time) and 50m above the bottom.

Table 7.107 CTD cast summary

Cast	Station	Julian Day	Max Depth/m	Altimeter	Notes
001	02	220	4031	10	Winch scrolling issues at 1166m on
002	08	221	407	10	Profile only – no bottles fired
003	13	223	1194	11	Profile only – no bottles fired
004	15 (WP80)	224	1300	100	SAP deployment #1 – 1hr pump at
005	23	227	660	96	SAP deployment #2 – 1hr pump at
007	34	231	1977	52	13hr tidal cycle yo-yo – profile 1
007	34	231	1976	50	yo-yo – profile 2
008	34	231	1977	52	yo-yo – profile 3
009	34	231	1978	50	yo-yo – profile 4
010	34	231	1978	50	yo-yo – profile 5
011	34	231	1976	48	yo-yo – profile 6
012	34	231	1974	39	yo-yo – profile 7
013	34	231	1968	40	yo-yo – profile - 20 bottles fired (5
014	39	233	2032	55	SAP deployment #3 – 1hr pump at
015	40 (WP80)	233	1305	99	Same location at CTD004 (Station
016	41	233	873	30	Profile only – no bottles fired
017	45	234	1788	60	SAP deployment #4 – 1hr pump at
018	47	235	1867	12	8 bottles fired (2 stops)
019	52	238	4000	-	PAP-site estimated depth 4840m
020	60 (WP80)	243	1305	99	SAP deployment #5 – 1hr pump at
021	64	244	2111	9	Glider Cal – Primary S fouling – 8

7.4.1.9. Data Processing

Sea-Bird CTD data processing of the raw data was completed using Sea-Bird Data Processing software.

The 'Recommended steps for basic processing of SBE-911 CTD data' were followed from the BODC document:

'BODC_Basic_onboard_SBE_CTD_data_processing_guidelines.doc' (Document version 1.0 October 2010)

The pre-processing order used was:

- Data Conversion
- Bottle Summary
- SeaPlot of pressure time-series to confirm no pressure spikes – WildEdit did not need to be run.
- Filter 0.15s on Pressure only
- AlignCTD 6s on oxygen channels only
- CellTM
- Derive – Depth Salt Water, Salinities, Oxygen Concentration – also separately SV
- BinAverage – 2Hz for BODC, 1Hz for LADCP processing, 25m for SVP
- Strip – to remove Depth Salt Water, Salinities and Oxygen Concentration
- ASCII Out for 1Hz (stripped), 2Hz (stripped) and 25m SVP

Scan count, elapsed time (seconds), NMEA latitude and longitude, and all instrument channels in engineering units and raw voltages were selected for data conversion. The primary and secondary oxygen channels were output in $\mu\text{mol/kg}$ and SBE raw V. The pressure hysteresis correction for oxygen was selected in the conversion.

The 6s advance that was applied in AlignCTD was applied to both primary and secondary oxygen channels for the $\mu\text{mol/kg}$, % saturation and SBE raw V fields.

The default parameter values were applied for the CellTM processing module.

There was also a requirement to produce 25m binned speed of sound profiles for correcting multi-beam swath data. The Bin Averaged files are named in the form JC237_CTDxxx_align_ctm_SV_25m.cnv and contain the Chen-Millero (m/s) speed of sound algorithm.

7.4.2. Workhorse 300 kHz LADCP

7.4.2.1. Instrument Configuration

Two self-logging Teledyne RDI Workhorse 300kHz ADCPs were installed on the CTD frame. Both units had the Lowered mode option installed and were used as an up/down pair with RDS3 synchronisation via the second serial interface via the star cable also installed on the CTD frame. The Master unit signals the pinging of the Follow by sending a synchronisation pulse over the second serial interface. The Follow unit pings immediately upon receipt of the synch pulse. The Master unit, on the other hand, waits 0.5 seconds after sending the synch pulse before it pings, i.e. for each ping, the follow unit will ping first. This reduces acoustic interference between the two LADCPs.

The down-looking unit (S/N: 12369) was sited at the centre of the frame with its transducers just above the bottom tube of the CTD frame. The up-looking unit (S/N: 4275) was located within an outrigger frame with its transducers just below the top tube of the CTD frame.

The instruments were powered with NMF Workhorse Battery Pack serial number WH010T.

Due to cable routing constraints, the instrument heads did not have their beams aligned in azimuth and therefore an offset will be observed between the compass headings of the two units. By convention, the down-looking unit is deployed as the master, and the up-looking unit as the follow unit.

Both instruments were configured with 25 off 8m bins and a 4m blank for a maximum range of 204m. Both instruments were set to ping as fast as they can. The ping period is limited by the sum of the ping, listening, processing and data storage times which in practice is of the order of 1.55 seconds (~0.645Hz).

The LADCPs were configured with 250cm/s for the Ambiguity Velocity (LV250). The maximum that LV can be set to in Narrowband mode (LW1) is 330cm/s (LV330).

Comments on SB0 Command

The recommendation in the 'Workhorse Commands and Output Data Format' manual (March 2016) for the use of SB0 to use Master/Follow setup was adhered to. This disables hardware-break detection on Channel B:

'Set SB0 to prevent noise from being processed as a <Break> on the RS-422 lines. This command is used when another system is connected to the ADCP over the RS-422 lines. In this configuration, disconnecting or connecting the other system can cause the ADCP to interpret this as a <Break> over Channel B. A break will cause the ADCP to stop pinging and the deployment will be interrupted.'

The manual also states: *'The SB command must be set to SB0 to use the Master/Slave setup.'*

The host laptop that was used for BBTalk was NTP time synchronised to the Discovery GPS clock using the Meinberg PC port of the UNIX NTP client. Thus, using the BBTalk script command \$T to set the LADCP clock to the PC time at the start of the command files ensures that the RTC of the Workhorses remain as close as feasible to UTC.

7.4.2.2. Deployment Command Scripts

Table 7.108 Overview of the command settings for the LADCPs

Down-looking Master	Up-looking Follow unit
<i>; JC237 Huvenne, NOC. LADCP Master ; Dougal Mountifield & Rob Hall (UEA)</i>	<i>; JC237 Huvenne, NOC. LADCP Slave ; Dougal Mountifield & Rob Hall (UEA)</i>
<i>\$T ; Set LADCP Clock to PC Time</i>	<i>\$T ; Set LADCP Clock to PC Time</i>
<i>PSO ; Display System Configuration</i>	<i>PSO ; Display System Configuration</i>
<i>CR1 ; Restore Factory Defaults</i>	<i>CR1 ; Restore Factory Defaults</i>
<i>WM15 ; LADCP Water Mode 15</i>	<i>WM15 ; LADCP Water Mode 15</i>
<i>CF11101 ; Disable Serial Output</i>	<i>CF11101 ; Disable Serial Output</i>
<i>EA00000 ; Zero Beam 3 Misalignment</i>	<i>EA00000 ; Zero Beam 3 Misalignment</i>
<i>(default)</i>	<i>(default)</i>
<i>EB00000 ; Zero Heading Bias (default)</i>	<i>EB00000 ; Zero Heading Bias (default)</i>
<i>EC1500 ; Speed of sound 1500 m/s</i>	<i>EC1500 ; Speed of sound 1500 m/s</i>
<i>(default)</i>	<i>(default)</i>
<i>ED00000 ; Zero Transducer Depth (default)</i>	<i>ED00000 ; Zero Transducer Depth (default)</i>
<i>ES35 ; Salinity 35PSU (default)</i>	<i>ES35 ; Salinity 35PSU (default)</i>
<i>EX00100 ; Beam Coordinates, use tilts</i>	<i>EX00100 ; Beam Coordinates, use tilts</i>
<i>EZ0011101 ; Use temp, heading and tilt</i>	<i>EZ0011101 ; Use temp, heading and tilt</i>
<i>sensors (use EC speed of sound, ED</i>	<i>sensors (use EC speed of sound, ED</i>
<i>depth, ES salinity)</i>	<i>depth, ES salinity)</i>
<i>TE00:00:01.00 ; 1 Second Minimum Time Per</i>	<i>TE00:00:01.00 ; 1 Second Minimum Time Per</i>
<i>Ensemble (default for WM15)</i>	<i>Ensemble (default for WM15)</i>
<i>TP00:01.00 ; 1 Second Minimum Time</i>	<i>TP00:01.00 ; 1 Second Minimum Time</i>
<i>Between Pings (default for WM15)</i>	<i>Between Pings (default for WM15)</i>
<i>LP00001 ; 1 Ping Per Ensemble (default)</i>	<i>LP00001 ; 1 Ping Per Ensemble (default)</i>
<i>LD111100000 ; Collect and Process all data</i>	<i>LD111100000 ; Collect and Process all data</i>
<i>(default)</i>	<i>(default)</i>
<i>LF0400 ; LADCP 4m Blank</i>	<i>LF0400 ; LADCP 4m Blank</i>
<i>LN025 ; LADCP 25 Bins</i>	<i>LN025 ; LADCP 25 Bins</i>
<i>LS0800 ; LADCP 8m Bins</i>	<i>LS0800 ; LADCP 8m Bins</i>
<i>LV250 ; LADCP 250cm/s Ambiguity</i>	<i>LV250 ; LADCP 250cm/s Ambiguity</i>
<i>Velocity (limited to max 330 in LW1</i>	<i>Velocity (limited to max 330 in LW1</i>
<i>mode)</i>	<i>mode)</i>
<i>LJ1 ; LADCP High Receiver Gain</i>	<i>LJ1 ; LADCP High Receiver Gain</i>
<i>(default)</i>	<i>(default)</i>
<i>LW1 ; LADCP Narrow Bandwidth</i>	<i>LW1 ; LADCP Narrow Bandwidth</i>
<i>(default)</i>	<i>(default)</i>
<i>LZ30,220 ; LADCP Default Bottom Detect</i>	<i>LZ30,220 ; LADCP Default Bottom Detect</i>
<i>and Correlation Thresholds</i>	<i>and Correlation Thresholds</i>
<i>SM1 ; RDS3 Master</i>	<i>SM2 ; RDS3 Slave</i>
<i>SA001 ; Send Sync Pulse Before Water</i>	<i>SA001 ; Wait for Sync Pulse Before Water</i>
<i>Ping (default)</i>	<i>Ping (default)</i>
<i>SBO ; Disable Hardware Break</i>	<i>SBO ; Disable Hardware Break</i>
<i>Detection on Channel B</i>	<i>Detection on Channel B</i>
<i>\$B ; Send a Break</i>	<i>\$B ; Send a Break</i>
<i>\$W">",2 ; Wait up to 2 seconds for prompt</i>	<i>\$W">",2 ; Wait up to 2 seconds for prompt</i>
<i>before continuing</i>	<i>before continuing</i>
<i>SW05000 ; Ping 500ms after Sending Sync</i>	<i>STO ; Wait Indefinitely For Sync Pulse</i>
<i>Pulse</i>	<i>From Master (default)</i>
<i>RN MAST_ ; Set file name header to MAST_</i>	<i>RN SLAV_ ; Set filename header to SLAV_</i>
<i>CK ; Save As User Defaults</i>	<i>CK ; Save As User Defaults</i>
<i>CS ; Start Pinging</i>	<i>CS ; Start Pinging</i>

7.4.2.3. LADCP Deployment & Recovery Procedure

Prior to each deployment the following standard checklist was followed:

Pre-deployment

- Baud rate changed to 9600 baud (**CB411**) to ensure correct parsing of command script file.
- Logging started (**F3**) to create deployment terminal capture log files named in the form *JC237_CTDxxxm.txt* for the master and *JC237_CTDxxxs.txt* for the follow unit.
- Instrument time checked (**TS?**) by comparing to GPS time. Manual setting of the instrument time was not required as the **\$T** script command was used in the command files.
- Free data storage available was checked and recorded (**RS?**), reformatting the card if required.
- The number of deployments on instrument storage card (**RA?**) was recorded.
- Three pre-deployment tests (**PA, PT200 and PC2**) were run being mindful of humidity sensor value.

Note that some of these tests are intended to be run with the instrument submerged in still water and can therefore be expected to fail in air.

- The command script files were sent to the instruments (**F2**) to deploy them and start them pinging. The follow unit was started first using *JC237_Slave.TXT*, followed by the master using *JC237_Master.TXT*. Finally the logging to the terminal capture was stopped (**F3**).
- The battery was then taken off charge, the deck-cables were disconnected and star-cable dummies installed ready for deployment.
- Prior to deployment pinging was confirmed by listening to the buzzers in the instruments.

Post-recovery

- Pinging was confirmed by listening to the buzzers in the instruments.
- Star-cable dummies were removed and deck-cables reconnected after drying the cables and connectors.
- The instruments were stopped pinging by sending a break to each in BBTalk, master first.
- The battery pack was put on charge (58V boost charge until 0.08A, then float at 55V).
- The baud rate was changed to 115200 baud (**CB811**) to reduce the data download time.
- The number of deployments on instrument storage card (**RA?**) was recorded.
- Download of data was started using BBTalk '**File>Recover Recorder**' menu command, selecting appropriate file(s) and noting their number in the default filename sequence *MAST_xxx.000* and *SLAV_xxx.000*.
- The baud rate was changed to 9600 baud (**CB411**) to ensure correct parsing of command script file.

The downloaded files were renamed using the form *JC237_CTDxxxm.000* for master and *JC237_CTDxxxs.000* for the follow unit. The files were then backed up to the network archive.

Data File Integrity & Data Quality Checks

Both the master and follow data files were checked using WinADCP. A region of data with high echo intensity (near bottom for master, near surface for follow) was selected. All four beams were checked for consistent echo intensity and beam correlation. Further similar checks were also done mid water-column and near the end of the profile. The start and stop times of the data files were checked for correspondence with the log-sheet deployment and recovery times. The number of pings (ensembles) in each data file was recorded on the log-sheet.

7.4.2.4. LADCP Deployment Comments

Instrument Terminal Lock-up During Deployment

Occasionally command script files are not parsed correctly by the instruments during deployment. This causes one instrument to lock up. When multiple breaks are then sent to the other instrument, the locked-up instrument would process each remaining line in the command file, then eventually say Wake-up B, then Wake-up AB, then finally Wake-up A.

The cause is still undetermined, but the work around is to send both instruments to sleep (CZ), then send a break to the Master first to wake it up, then a break to the Follow unit to wake it up, then (most importantly) send a second break to the Master. Then the command script files are sent to the follow unit followed by the master to deploy them. This process was used during the cruise and worked without exception.

Spares Availability

Three additional spare TRDI Workhorse 300 kHz LADCP instruments were available on-board. Rob Hall (UEA) used Andreas Thurnherr's LADCP shear inversion software for LADCP profile integration. This indicated that both instruments used on the CTD frame were operating normally and had no identifiable issues.

7.4.3. Stand-Alone Pumps (SAPs)

A single SAP was mounted on the CTD rosette adapter plates using a new adapter design. This locates the pancake filter plate and filter housing above the top ring of the CTD frame and above the top of the CTD bottles. The SAP pressure housing used was 'Minnie' as it has a shorter (and lighter) pressure housing. The pancake housing and volume meter from 'Bambi' was used as they were in the best condition.

The volume meter accuracy was confirmed with the MilliQ calibrated measured volume function. On the first CTD cast, the SAP was run with no filter fitted in the housing as a functional test and to confirm the maximum likely in situ volumes. The unit pumped 2463 l in 1.5 hours (1642 l/hr), and the unit stopped pumping 1 minute before the end of the 1.5 hour period due to a low battery condition. The usual SAP pump period of 1 hour was used for all the scientific deployments during JC237.



Fig. 7.122 Photograph of the SAPS setup

Five deployments were completed with 2 GF/F filters loaded, one directly on top of the other, on the spiral filter support plate in a single pancake housing. The housing was washed with MilliQ in between deployments. Foil was used on the intake and exhaust to keep air-borne dust out of the filters between loading and deployment.

Table 7.109 SAP deployments during JC237

SAP Deployment	Julian Day	Station	CTD Cast	Pump Depth /m	Pre-deployment Volume /m ³	Post-deployment Volume /m ³	Volume Pumped /litres
1	224	15 (WP80)	004	1300m	0309.807	0310.268	461
2	227	23	005	660m	0310.270	0311.005	735
3	233	39 (WP163)	014	2030m	0311.008	0311.675	667
4	234	45	017	1500m	0311.676	0312.388	712
5	243	60 (WP80)	020	1305m	0312.389	0312.925	536

The 1 hour pumping period was confirmed to have been completed by checking the SAP with a terminal after recovery. No battery issues were experienced. The new design pump-head assembly that was fitted to the unit had no issues. New bushes were fitted to the pump impeller during the mobilisation.

To maintain the condition of the batteries (and to supply the standby current of the electronics board), the SAP was left on float charge (18.3V at the battery packs) continuously when not in use.

The SAP unit was reliable and the pumped volumes were as expected for the filter load and in-situ loading. The filters obtained at WP80 (SAP deployment #1 and #5) were highly loaded with in-situ material.

7.4.4. Salinometry

Following each CTD cast, discrete salinity samples were taken from the OTE 10l water samplers. All samples were taken and analysed by the NMF CTD Technician. The salinometer was operated in the Electronics Workshop with the bath temperature set to 24°C. The HVAC plant in the Electronics Workshop was set at 22.0°C to achieve an ambient temperature of 21.5-22.5°C.

7.4.4.1. Salinity Sample Summary

35 discrete salinity samples were taken during the cruise over 2 crates. 2 crates of CTD samples were analysed comprising all 35 discrete CTD samples. No TSG samples were taken or analysed during the cruise. All samples were analysed using the Guildline Autosal model 8400B salinometer s/n: 72227.

The analysis protocol was to run a standard as a sample as a control before and after each crate of samples. After standardisation on 28 August, the RS pot was not adjusted again during the cruise and the machine was not re-standardised using the software.

A data file from the analysis software was produced for each crate as an Excel spreadsheet. All raw double conductivity measurements were also logged manually by the analyst on paper log-sheets. These log-sheets were scanned to pdf format by the NMF Sensors & Moorings Technician. There were 3 sheets of salinity rough logs in total including the standardisation sheet.

7.4.4.2. IAPSO Standard Seawater Batch

IAPSO Standard Seawater batch **P164** was used during the cruise:

Batch Date: 23rd March 2020

Expiry Date: 23rd March 2023

$K15 = 0.99985 \pm 0.00001$ ($2 \times K15 = 1.99970 \pm 0.00002$)

Practical Salinity = 34.994 ± 0.001

10 bottles of P164 standard were available.

7.4.4.3. Autosal Analysis Software

The NMF Labview Autosal program was checked to ensure correct read/write access and function of the standardisation .ini file on both machines. Both machines functioned correctly, writing the correct offset to the file at standardisation and reading the correct offset during analysis of samples.

7.4.4.4. Standardisation

A pre-standardisation stability check was completed on 27 August with the instrument found to be measuring 0.00010 high in double conductivity ratio (RS 538, standby 6045/6046 – from the last standardisation on 14 July). The unit was standardised using P164 by Dougal Mountfield on 28 August (RS 549, standby 6036) with the instrument reading 0.000026 low in double conductivity ratio. A further stability check using P164 was done at the same time. An additional ‘pre-sample run’ stability check was completed before each use using P165 ‘sub-standard’ (recent remaining used standards that had been capped immediately after use).

7.4.4.5. Guildline Autosal 8400B s/n: 72227

The Guildline Autosal 8400B S/N 72227 was commissioned by the NMF Sensors & Moorings Technician during the mobilisation of the previous cruise JC238 (OSNAP) on 10 July. A standard deviation limit of 0.00002 was used for all measurements. The unit was found to be stable (RS 549, standby 6035/6) with control standards measured to within 0.001 in salinity. The instrument performed excellently and continued to do so for the remainder of the cruise.

7.4.4.6. Discrete CTD Salinity Analysis, Characterisation and Adjustment

A full worked up data-set for the discrete CTD salinity samples was completed by the NMF Sensors & Moorings Technician. This was provided as a separate document along with detailed notes, charts, regressions and adjustments in separate tabs as ‘JC237_CTD_Salinities.xls’.

7.4.4.7. Vaisala Ambient Temperature & Humidity Monitoring in for Salinometry

A new ambient temperature & humidity monitoring system is now available in the Electronics Workshop (space 237). The system was installed by the Sensors & Moorings Technician during JC238. The system will allow continuous monitoring of the ambient operating environment of the Salinometer. The data from the system is also logged to a database which will provide an audit trail for salinometry. The database system software also provides alarm and reporting functions.

Four Vaisala RFL100 remote Vainet loggers using HMP-115 temperature & humidity probes are mounted in the following locations in the ET Workshop:

- HVAC Control Reference - Local probe adjacent to HVAC control reference & set-point control by door
- HVAC Intake - Remote probe fixed to the HVAC intake grid in the deck-head to the right-hand side of the Salinometer location
- HVAC Exhaust - Remote probe fixed to the HVAC exhaust louvre in the deck-head adjacent to the HVAC control cabinet

- Autosal Ambient - Local probe on bulkhead in corner of the space to the left-hand side of the Salinometer location

Each of the RFL100 loggers takes a measurement every minute and then uploads these every 4 minutes to the AP10E base station via the Vainet radio. Vainet is Vaisala's proprietary low power radio that was developed from LoRa IoT spread-spectrum technology. The AP10E base station was mounted on the bulkhead to the left-hand side of the Autosal Ambient RFL100 logger.

The AP10E base station is connected to the ship's network via an RJ-45 UTP network cable through which it connects to the Vaisala ViewLinc database software. For testing and system familiarisation the ViewLinc software was installed on one of the SAP/LADCP laptops. It is proposed that a dedicated 1U rack server is procured and installed in the Computer Locker to run ViewLinc.

Both the AP10E base station and laptop running ViewLinc were allocated fixed IP addresses and added to the DNS as follows:

AP10E base station – vainet.cook.local – 192.168.62.99

Laptop running ViewLinc – viewlinc.cook.local – 192.168.62.100

7.4.4.8. Electronics Workshop HVAC Configuration

Changes were made to the configuration of the HVAC system in the Electronics Workshop to improve the temperature stability of the space. The **E-17** Exhaust Fan was **started** to ensure a flow of air past the temperature sensor. The remote temperature set point control by the door also houses the room temperature sensor the control system. The Exhaust fan intake is above this in the deckhead.

Due to the prevailing cold climate, the **EL.Heating Coil in FC-3** switch was set in the **ON** position to enable the heating subsystem of the HVAC in the space. The **FC-5 Supply Fan** Main switch was set in the **ON** position and the fan was confirmed to be running. To provide a fresh air supply to the Electronics Workshop, the deckhead mounted air damper was set to provide a gentle trickle of fresh air.

The **RWC62** Temperature Controller settings were changed to reduce dead-band and overshoot and to increase the assertiveness of the control. The **xDZ** dead-band setting was reduced from 1.0 °C to **0 °C**. The **TN** Integral time was increased from 256 seconds to **1024 seconds**, this yields integral action over 17 minutes. The **xP1** Heat proportional band was reduced from 15 °C to **3.0 °C** and the **XP2** Cool proportional band reduced from 15 °C to **5.0 °C**.

The Danfoss **VLT2800** fan controller settings were changed to increase the exhaust air temperature during the heat cycle, reduce re-ingestion of condensate and prevent controller trip-out during fan start. The following parameters were changed:

102 – Motor Power set to the face-plate value of **0.66kW**

204 – Output Freq low limit increased to **10** from 0 (this prevents the slow speed trip properly)

205 – Output Freq high limit reduced from 50 to **35** (this prevents condensate being re-ingested from the trap)

204-212 Ramp times increased from 3 seconds to **5** secs

213 Jog frequency set to **20** (this is the fixed fan speed in 'jog' mode when the heater relay is active.

640 noted the software version is **2.84**

405 reset function changed from manual to **auto 3** attempts

406 auto-restart time **5s** (default)

002 local/remote set to **0** (remote)

7.4.5. **Software Used**

Sea-Bird Seasave 7.26.7.121 (SBE 9/11plus data acquisition)

Sea-Bird SBE Data Processing 7.26.7.121 (SBE 9/11plus data processing)

Notepad ++ 7.6 (Data-file and Header viewing)

Moxa PComm Terminal Emulator 2.10 (Serial port testing)

7.5. Deep Glider

Operational Team: Rob Hall, Glider team at NOC

The Deep Glider was deployed during expedition DY152, just before JC237. Full details on deployment and initial missions can be found in the cruise report of DY152 (Phillips et al., in prep.).

7.5.1. Deep Glider background information (from DY152 cruise report)

Like other Seagliders (C2 and M1), the Deepglider (M6) propels itself through the water using a variable buoyancy system device (VBD) to achieve vertical velocity. The vehicle's wings then translate that vertical velocity into forward motion. This results in a saw-tooth shaped trajectory through the water. The Deepglider, however, represents a giant leap forward in the deep diving ocean glider capabilities. Its maximum operation depth of 6000 meters allows it to perform full depth profiles in over 98% of the world's ocean this opening new realms to oceanography data collection.

The vehicle's large variable buoyancy allows operation even in significantly stratified waters. It also enables the glider to generate up to 1 knot of forward velocity, making it easier to operate in areas of relatively high currents.

Its passive buoyancy compensation scheme minimizes the amount of oil that must be transferred, therefore saving significant energy. Typical sensors include conductivity/temperature, oxygen optode and fluorometer/optical backscatter devices.

NOC owns the Deepglider S/N 042, manufactured by the University of Washington (UW).

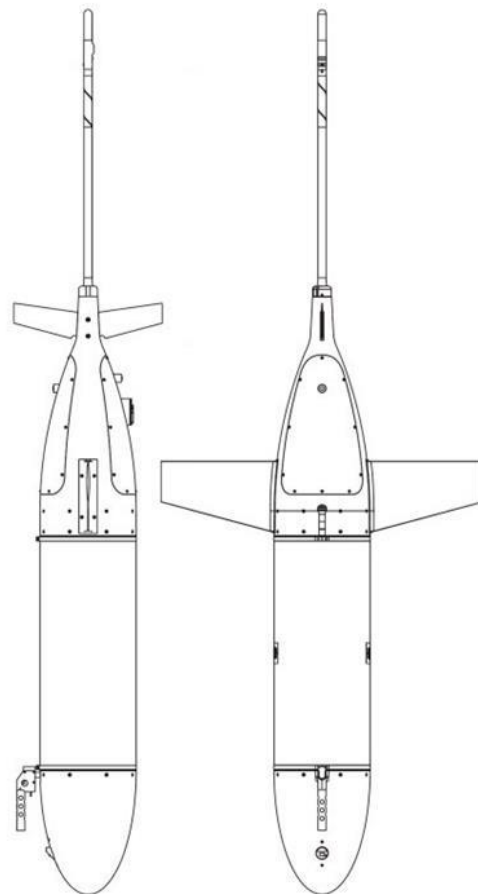

Fig. 7.123 Deep Glider S/N 042 and vehicle schematics

7.5.2. Technical specifications (from DY152 cruise report)

Mechanical

- • Body Length: 1.8 m
- • Body diameter: 30 cm maximum
- • Wing span: 1 m
- • Antenna mast length: 1 m
- • Weight: 79 kg (in air)

Operation

- • Maximum depth: 6000 m
- • Typical speed: 0.2 – 0.5 m/s
- • Glide angle: 14 – 45 degrees
- • Variable buoyancy: 1125 cc
- • Maximum range: 10000 km (~250 profiles to 6000m)

Electrical

- • Power source: Lithium primary batteries, 24V & 10V, 16.5 MJ
- • Memory storage: 1GB SD card
- • Sensor interfaces: RS-232, frequency input

Communications

- • Telemetry: Iridium RUDICS communications
- • Pre-launch test & programming: RS-232

Navigation & Control

- • Integrated GPS module provides position while at surface
- • Dead reckoning while submerged using 3-axis compass and pressure sensor
- • Integrated altimeter & bathymetry map features for near bottom profiles
- • Kalman filter for prediction of mean and oscillatory currents

(Text and info based on Kongsberg's Seaglider M6 brochure – April 2017)

7.6. Ship-fitted Systems

Operational team: Eleanor Darlington

7.6.1. Scientific computer systems

7.6.1.1. Underway data acquisition

Data from the suite of ship-fitted scientific instrumentation was aggregated onto a network drive on the ship's file server. This was available throughout the voyage in read-only mode to permit scientists to work with the data as it was acquired. A Public network folder was also available for scientists to share files.

A copy of these two drives are written to the end-of-cruise disks that are provided to the Principal Scientist and the British Oceanographic Data Centre (BODC).

List of logged ship-fitted scientific systems:

/Cruise_Reports/JC237_Ship_fitted_information_sheet.docx

The data acquisition systems used on this cruise are detailed in the table below. The data and data description documents are filed per system in the *Data* and *Documentation* directories respectively within Ship Systems folder on the cruise data disk.

Table 7.110 Data acquisition systems used on this cruise.

Data acquisition system	Usage	Data products	Directory system name
Ifremer TechSAS	Continuous	NetCDF ASCII pseudo-NMEA	/TechSAS/
NMF RVDAS	Continuous	ASCII Raw NMEA SeaDataNet NetCDF (Testing)	/RVDAS/
Kongsberg SIS (EM122)	Discrete	Kongsberg .all	/Acoustics/EM-122/
Kongsberg SIS (EM710)	Discrete	Kongsberg .all	/Acoustics/EM-710/
Kongsberg SBP	Continuous	None	/Acoustics/SBP-120/
Kongsberg EA640	Continuous	None, redirected to Techsas/RVDAS RAM	/Acoustics/EA-640/
Kongsberg EK60/80	Unused		/Acoustics/EK-60/
UHDAS (ADCPs)	Continuous	ASCII raw, RBIN, GBIN, CODAS files	/Acoustics/ADCP/
VMDAS (ADCPs)	Unused		/Acoustics/ADCP/
Sonardyne Ranger2	Discrete	None, redirected to Techsas/RVDAS RAM	/Acoustics/USBL/

Data description documents per system:

/Ship_Systems/Documentation/[System]/Data_Description

Data directories per system:

/Ship_Systems/Data/[System]/

7.6.1.1.1 Significant acquisition events and gaps

On this cruise, the NMF Event Logger/BAS Event Logger was used with CSV records of events saved to the cruise data directory. This was for SSS events. The science party used their own event logging system.

Table 7.111 Summary of data gaps

<i>Date</i>	<i>Time start*</i>	<i>Time end*</i>	<i>Event</i>
7 th August 2022	00:01	10:00	ADCPs failure.
Intermittent			Seapath330 GPS feed was intermittent in TechSAS recording.

Path and pattern to event log CSV files:

/Cruise_Reports/Event_Logs/backups/csv/[logName]/*.csv

7.6.1.2. Internet provision

Satellite communications were provided with both the VSat and Fleet Broadband systems.

While underway, the ship operated with bandwidth controls to prioritise business use. Connection was maintained throughout, using more than contracted on download, and the limit on upload.

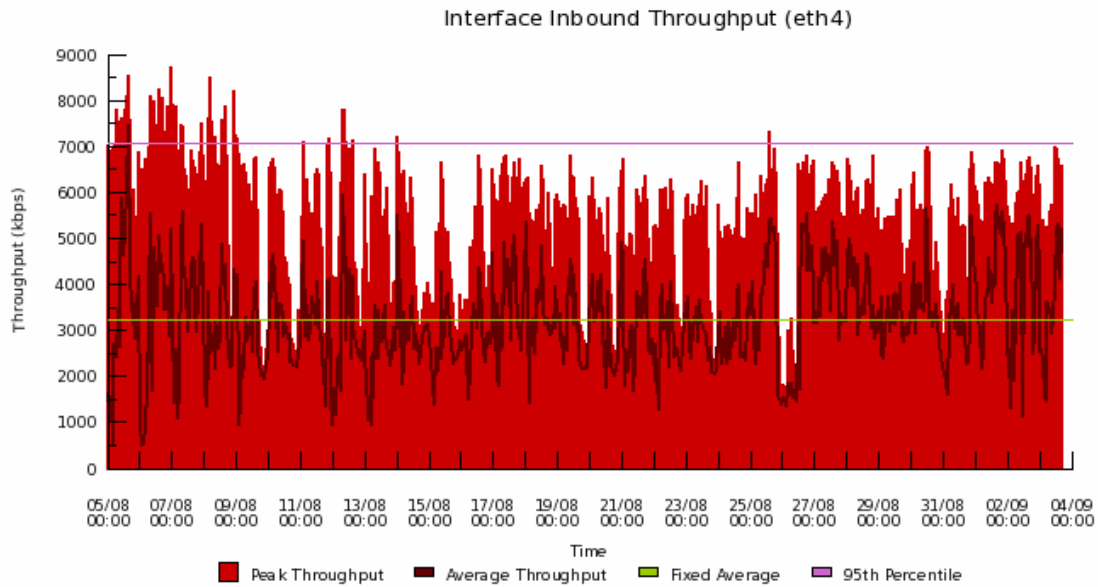

Fig. 7.124 Data download through VSAT

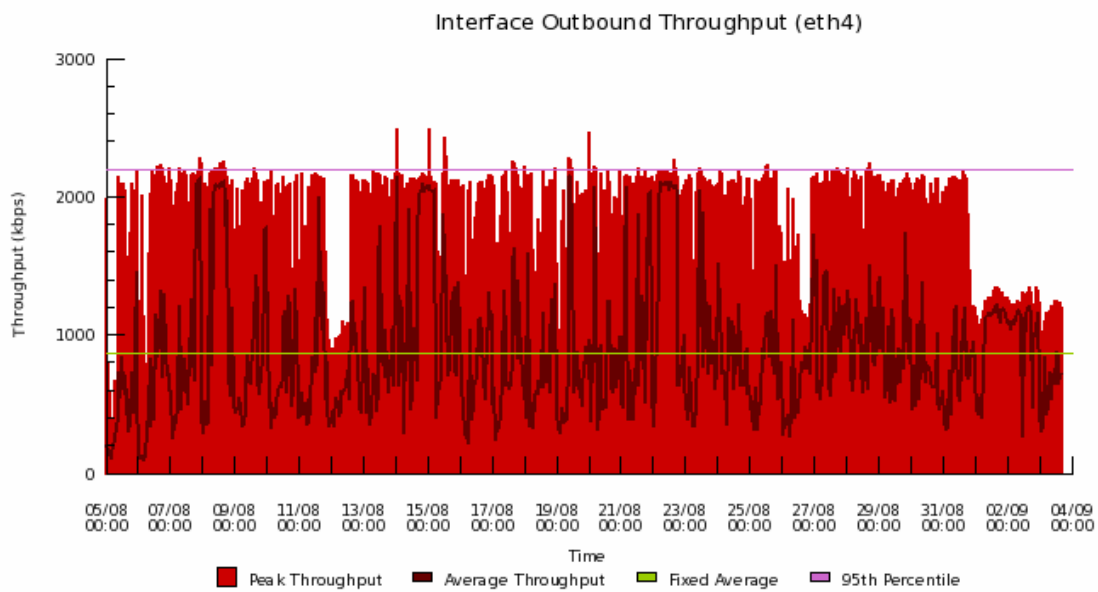

Fig. 7.125 Data uploaded through VSAT

7.6.1.3. Outreach and streaming

Three ten-hour streaming sessions were held overnight during the ROV ISIS dives at PAP (Friday 25th, Saturday 26th and Sunday 27th August 2022). This used Microsoft Teams; the scientists onshore communicated to the science team onboard via the chat box function.

7.6.2. Instrumentation

7.6.2.1. Coordinate reference

Path to ship survey files:

/Ship_Systems/Documentation/Vessel_Survey

7.6.2.1.1 Origin (RRS James Cook)

The common coordinate reference was defined by the Blom Maritime survey (2006) as:

1. The reference plane is parallel with the main deck abeam (transversely) and with the baseline (keel) fore- and aft-ways (longitudinally).
2. Datum ($X = 0, Y = 0, Z = 0$) is centre topside of the Applanix motion reference unit (MRU) chassis.

7.6.2.1.2 Multibeam

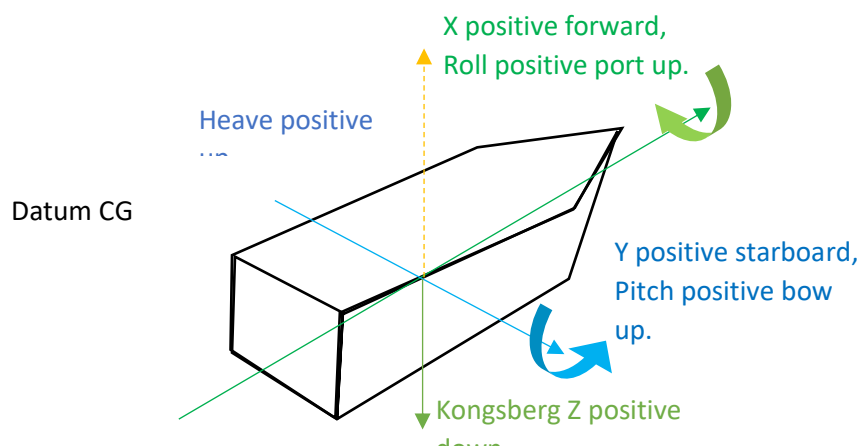

Fig. 7.126 Conventions used for position and attitude. On the Discovery, the Datum is the CRP at the CG. On the RRS James Cook the Datum is on the centre, topside of the Applanix MRU.

The Kongsberg axes reference conventions are (see Fig7) as follows:

1. X positive forward,
2. Y positive starboard,
3. Z positive downward.

The rotational sense for the multibeam systems and Seapath is set to follow the convention of Applanix PosMV (the primary scientific position and attitude system), as per Fig7.

7.6.2.1.3 Primary scientific position and attitude system

The translations and rotations provided by this system (Applanix PosMV) have the following convention:

1. Roll positive port up,
2. Pitch positive bow up,
3. Heading true,
4. Heave positive up.

7.6.2.2. Position, attitude and time

Table 7.112 Details of ship's attitude measurements

System	Navigation (Position, attitude, time)		
Statement of Capability	/Ship_Systems/Documentation/GPS_and_Attitude		
Data product(s)	NetCDF: /Ship_Systems/Data/TechSAS/NetCDF/ Pseudo-NMEA: /Ship_Systems/Data/TechSAS/NMEA/ Raw NMEA: /Ship_Systems/Data/RAM/NMEA/		
Data description	/Ship_Systems/Documentation/TechSAS /Ship_Systems/Documentation/RAM		
Other documentation	/Ship_Systems/Documentation/GPS_and_Attitude		
Component	Purpose	Outputs	Headline Specifications
Applanix PosMV	Primary GPS and attitude.	Serial NMEA to acquisition systems and multibeam	Positional accuracy within 2 m.
Kongsberg Seapath 330	Secondary GPS and attitude.	Serial and UDP NMEA to acquisition systems and multibeam	Positional accuracy within 1 m.
Oceaneering CNav 3050	Correction service for primary and secondary GPS and dynamic positioning.	? to primary and secondary GPS	Positional accuracy within 0.15 m.
Fugro Seastar / MarineStar	Correction service for primary and secondary GPS and dynamic positioning.	? to primary and secondary GPS	Positional accuracy within 0.15 m.
Meinberg NTP Clock	Provide network time	NTP protocol over the local network.	?

7.6.2.2.1 Significant position, attitude or time events or losses

Table 7.113 List of faults in ship's attitude measurements

Date	Time start*	Time end*	Event
Continuous			Seapath 330 dropped signal, preventing it being sent to TechSAS. However, RVDAS/RAM recorded continuously and can be used to fill any gaps.

7.6.2.3. Ocean and atmosphere monitoring systems

7.6.2.3.1 SURFMET

Table 7.114 Settings of the SURFMET system during JC237

System	SURFMET (Surface water and atmospheric monitoring)	
Statement of Capability	/Ship_Systems/Documentation/Surfmet	
Data product(s)	NetCDF: /Ship_Systems/Data/TechSAS/NetCDF/ Pseudo-NMEA: /Ship_Systems/Data/TechSAS/NMEA/ Raw NMEA: /Ship_Systems/Data/RAM/NMEA/	
Data description	/Ship_Systems/Documentation/TechSAS /Ship_Systems/Documentation/RAM	
Other documentation	/Ship_Systems/Documentation/Surfmet	
Calibration info	See Ship Fitted Sensor sheet for calibration info for each sensor.	
Component	Purpose	Outputs
Inlet temperature probe (SBE38)	Measure temperature of water at hull inlet	Serial to Interface box
Drop keel temperature probe (SBE38)	Measure temperature of water in drop keel space	Serial to Moxa
Thermosalinograph (SBE45)	Measure temp, sal and conductivity at sampling board	Serial to Interface Box
Interface Box (SBE 90402)	Signals management	Serial to Moxa
Debubbler	Reduces bubbles through instruments.	
Transmissometer (CST)	Measure of transmittance	Serial to Interface Box
Fluorometer (WS3S)	Measure of fluorescence	Serial to Interface box.
Air temperature and humidity probe (HMPxxx)	Temperature and humidity at met platform	Analogue to NUDAM
Ambient light sensors (PAR, TIR)	Ambient light at met platform	Analogue to NUDAM
Barometer (PTBxxx)	Atmospheric pressure at met platform	Analogue to NUDAM
Anemometer (Windsonic)	Wind speed and direction at met platform	Serial to Moxa
NUDAM	A/D converter	Serial NMEA to Moxa
Moxa	Serial to UDP converter	UDP NMEA to Surfmet VM
Surfmet Virtual Machine	Data management	UDP NMEA to TechSAS, RVDAS

The NMF Surfmet system was run throughout the cruise, excepting times for cleaning, entering and leaving port, and whilst alongside. Please see the separate information sheet for details of the sensors used and whether their recorded data have calibrations applied or not.

The ship engineers put cleaning solution throughout the vessel non-toxic seawater supply while in port. This caused excess bubbling when the system was turned on. It likely needed at least 24 hours

for the solution to be flushed through before sampling started. Treat first 48 hours of surface water measurements with caution.

7.6.2.3.1.1 Surface water sampling board maintenance

Table 7.115 *JC237 SURFMET maintenance events*

<i>Date</i>	<i>Start</i>	<i>End</i>	<i>Event</i>	<i>Trans high (V)</i>	<i>Trans low (V)</i>	<i>Fluoro (V)</i>	<i>Salinity (PSU)</i>
18/08/2022	09:19	09:48	Cleaning			0.0662	35.57
23/08/2022	14:07	14:45	Cleaning			0.0659	35.57

7.6.2.3.2 Wave radar

Table 7.116 JC237 WAMOS settings

System	WAMOS Wave Radar		
<i>Statement of Capability</i>	/Ship_Systems/Documentation/Wamos		
<i>Data product(s)</i>	NetCDF: /Ship_Systems/Data/TechSAS/NetCDF/ Raw NMEA: /Ship_Systems/Data/RAM/NMEA/ Raw: /Ship_Systems/Data/Wamos/		
<i>Data description</i>	/Ship_Systems/Documentation/TechSAS /Ship_Systems/Documentation/RAM		
<i>Other documentation</i>	/Ship_Systems/Documentation/Wamos		
<i>Component</i>	<i>Purpose</i>	<i>Outputs</i>	<i>Headline Specifications</i>
Rutter OceanWaves WAMOS	Measure wave height, direction, period and spectra.	Summary statistics in NMEA to TechSAS and RVDAS. Spectra files.	
RsAqua Rex2 Wave Height Sensor	Measure wave height at bow to provide calibration reference dataset.	Wave height NMEA, UDP to TechSAS, RVDAS.	
Furuno Radar	Measures radar reflection on sea surface.	Radar data to WAMOS.	

The wave radar magnetron requires annual replacement. Following replacement, WAMOS needs to collect wave data within 5 km of another wave height sensor over the full range of sea-states in order to derive wave height calibration coefficients for the new magnetron. This reference dataset can be derived by examining the ship's track for wave buoys and downloading their data, or by using the onboard RsAqua Wave Height sensor fitted on the ship's bow.

7.6.2.4. Hydroacoustic systems

Table 7.117 Usage of ship's Acoustic systems during JC237

System	Acoustics		
<i>Statement of Capability</i>	<i>/Ship_Systems/Documentation/Acoustics</i>		
<i>Data product(s)</i>	Raw: <i>/Ship_Systems/Data/Acoustics</i> NetCDF (EA640, EM122cb): <i>/Ship_Systems/Data/TechSAS</i> NMEA (EA640, EM122cb): <i>/Ship_Systems/Data/RVDAS</i>		
<i>Data description</i>	<i>/Ship_Systems/Documentation/Acoustics</i>		
<i>Other documentation</i>	<i>/Ship_Systems/Documentation/Acoustics</i>		
Component	Purpose	Outputs	Operation
10/12 kHz Single beam (Kongsberg EA-640)	Primary depth sounder	NMEA over serial, raw files	Continuous Triggered
12 kHz Multibeam (Kongsberg EM-122)	Full-ocean-depth multibeam swath.	Binary swath, centre-beam NMEA, *.all files, optional water column data	Continuous Triggered
70 kHz Multibeam (Kongsberg EM-710)	Coastal/shallow multibeam swath.	Binary swath, centre-beam NMEA, *.all files.	Continuous Triggered
Sub-bottom Profiler (Kongsberg SBP-120)	Multi-frequency echogram to provide along-track sub-bottom imagery.	BMP, raw files, optional water column data.	Discrete Triggered
Drop keel sound velocity sensor	Provide sound velocity at transducer depth	Value over serial to Kongsberg SIS.	Continuous
Sound velocity profilers (Valeport Midas, Lockheed XBT)	Direct measurement of sound velocity in water column.	ASCII pressure vs sound velocity files. Manually loaded into Kongsberg SIS or Sonardyne Ranger2.	Discrete (See deployment event log, below)
75 kHz ADCP (Teledyne OS75)	Along-track ocean current profiler	(via UHDAS)	Continuous Free running
150 kHz ADCP (Teledyne OS150)	Along-track ocean current profiler	(via UHDAS)	Continuous Free running
USBL (Sonardyne Ranger2)	Underwater positioning system to track deployed packages or vehicles.	NMEA over serial	Discrete (See deployment event log, below)
CARIS	Post-processing	CARIS Project file. CARIS Vessel files	Unused
MB-System	Post-processing	XYZ, SegY files	Unused

7.6.2.4.1 Marine Mammal Protection

Path to Marine Mammal Observation logs:

`/Ship_Systems/Documentation/Acoustics/MMOs`

Table 7.118 Observations taken by JNCC representative.

<i>System</i>	<i>Actions taken to protect mammals, in compliance with NERC and JNCC protocols</i>
12 kHz Multibeam (Kongsberg EM-122)	60-minute bridge observation. Marine mammal protection ramped start initiated at 45 minutes into observation if no mammals sighted. Clock restarted if mammals sighted.
Sub-bottom Profiler (Kongsberg SBP-120)	As above.

7.6.2.4.2 Sound velocity profiles

Sound velocity profiles were collected with the Midas SVP probe (S/N:), XBT, or derived from CTD or calculated from the WOA13 model using Ifremer DORIS.

Path of sound velocity profile data on the cruise datastore:

`/Ship_Systems/Data/Acoustics/Sound_Velocity`

Details of when sound velocity profiles were taken and applied are shown in the table below. Profiles were uploaded into Ranger2 and sent to EM122 and EM710 via UDP. The two below were used for the Ranger2 software, the earlier one for the Whittard Canyon and the latter for PAP. Some additional profiles were derived from CTD and were sent to the multi-beams as necessary.

Table 7.119 JC237 Sound velocity profiles.

<i>Datetime</i>	<i>Method</i>	<i>Location (Lat/Lon)</i>	<i>Filename</i>
08/08/2022	MIDAS SVP	47.870571 -10.175577	Midas_SVP_08082022
26/08/2022	MIDAS SVP	48.851061 -16.53552	JC237_MIDAS_26082022

7.6.2.4.3 Significant acoustic events or losses

Table 7.120 Faults experienced with the ship's acoustic systems

<i>Date</i>	<i>Time start*</i>	<i>Time end*</i>	<i>Event</i>
26/08/2022			Once at PAP site realised the depths were wrong. EA640 discovered to have wrong sound velocity in it, causing a 30 m error in depth. SV profile was 1491 m/s from 'calculated'. Changed back to manual SV of 1500 m/s

7.6.2.4.4 Equipment-specific comments

7.6.2.4.4.1 ADCPs

Path of ADCP data on the cruise datastore:

/Ship_Systems/Data/Acoustics/ADCP

Table 7.121 ADCP settings during JC237

Attribute	Value
Acquisition software	UHDAS
Frequencies used	75 kHz, 150 kHz
Running mode	Free-running (untriggered)
Configuration details	Bin size, blanking distance,

The screenshot shows the UHDAS software interface for cruise ID JC237_A. The 'Control' tab is selected, displaying 'Cruise Setup' and 'Data Recording' sections. The 'RDI os150 Data Collection Parameters' and 'RDI os75 Data Collection Parameters' are shown in two columns. The 'New' and 'Present' columns indicate the current and previous values for various parameters. The 'Commands' list at the bottom of each parameter set includes: NP1, NN50, NS800, NF400, WPO, WN80, WS400, WF400, BPO, BX5000, TP00:01.10, and CX0,0.

ADCP's were run throughout. Failure of PC hardware caused 12 hour of no acquisition en-route to Whittard Canyon. No other issues.

7.6.2.4.4.2 EM-122 Configuration and Surveys

Path of Multibeam data on the cruise datastore:

/Ship_Systems/Data/Acoustics/EM-122

Table 7.122 EM122 settings during JC237

<i>Attribute</i>	<i>Value</i>			
Number of surveys	(Run continuously)			
Date of patch test	Not undertaken.			
Offsets and rotations	<i>Item</i>	<i>X (m, + Forward)</i>	<i>Y (m, + Starboard)</i>	<i>Z (m, + Down)</i>
	Tx transducer	19.205	1.830	6.934
	Rx transducer	14.094	0.950	6.932
	<i>Item</i>	<i>Roll (deg)</i>	<i>Pitch (deg)</i>	<i>Yaw (deg)</i>
	Tx transducer	-0.35	-0.1	0.19
	Rx transducer	-0.06	0.1	0.15
Post-processing undertaken	By science party (see section 6.1)			

Science party ran the EM122 during surveys and configured it per their survey requirements.

7.6.2.4.4.3 EM-710 Configuration and Surveys

Path of Multibeam data on the cruise datastore:

/Ship_Systems/Data/Acoustics/EM-710

Table 7.123 EM710 settings during JC237

Attribute	Value			
Offsets and rotations	<i>Item</i>	<i>X (m, + Forward)</i>	<i>Y (m, + Starboard)</i>	<i>Z (m, + Down)</i>
	Tx transducer	5.415	-0.015	6.965
	Rx transducer	4.988	0.013	6.965
	Att 1 (Applanix)	0	0	0
	Att 2 (Seapath)	-0.350	0.056	-0.373
	Waterline (distance from Att 1 to W/L)			1.2
	<i>Item</i>	<i>Roll (deg)</i>	<i>Pitch (deg)</i>	<i>Heading (deg)</i>
	Tx transducer	-0.418	0.228	0.000
	Rx transducer	0.130	0.00	0.00
	Att 1 (Applanix)	-0.45	0.68	-0.38
	Att 2 (Seapath)	-0.46	0.39	-1.01

7.6.2.4.4.4 SBP-27 Configuration and Surveys

Path of sub-bottom profile data on the cruise datastore:

/Ship_Systems/Data/Acoustics/SBP-120

Table 7.124 SBP survey summary for JC237

<i>Attribute</i>	<i>Value</i>
Number of surveys	1 - continuous
Post-processing undertaken	None

The SBP27 was run when necessary on external trigger in K-Sync. This was operated by the science party and primarily used to identify suitable coring sites.

7.6.2.4.4.5 USBL Configuration and deployments

Path of USBL calibration information on the cruise datastore:

/Ship_Systems/Data/Acoustics/USBL

Table 7.125 USBL settings for JC237

<i>Attribute</i>	<i>Value</i>
Number of deployments	Discrete – used for tracking Autosub5 and CTD deployments
Datetime of last CASIUS	08/02/2022
Starboard Head 1DRMS	Out of calibration since refit 2022
Port Head 1DRMS	63.2 % of beacon positions within 0.40 % Depth At 4560 m depth, 63.2 % of positions are within 18.1 m, 86.5 % are within 26.0 m, 98.2 % are within 43.0 m.

Table 7.126 USBL Beacon Deployment information:

<i>Deployment name</i>	<i>Head used</i>	<i>Beacon(s) used</i>	<i>Instrument tracked</i>	<i>SVP Used (Filename)</i>
	Port	2212	CTD Frame	
	Port	2004	ROV ISIS	
	Port	N/A	Autosub5 used own beacons as per their report	

7.6.2.5. Other systems

7.6.2.5.1 Cable Logging and Monitoring

Winch activity is monitored and logged using the CLAM system. The Active Heave Compensate was not working/operational during JC237. All CTD and coring was undertaken without using it.

8. REFERENCES

- Allen, S. E., and Durrieu de Madron, X., 2009, A review of the role of submarine canyons in deep-ocean exchange with the shelf: *Ocean Science*, **5**, p. 607-620. doi:10.5194/os-5-607-2009
- Amaro, T., Huvenne, V. A. I., Allcock, A. L., Aslam, T., Davies, J. S., Danovaro, R., de Stigter, H. C., Duineveld, G. C. A., Gambi, C., Gooday, A. J., Gunton, L. M., Hall, R., Howell, K. L., Ingels, J., Kiriakoulakis, K., Kershaw, C. E., Lavaleye, M. S. S., Robert, K., Stewart, H., Van Rooij, D., White, M., and Wilson, A. M., 2016, The Whittard Canyon - a case study of submarine canyon processes: *Progress in Oceanography*, **146**, p. 38-57. doi:10.1016/j.pocean.2016.06.003
- Aslam, T., Hall, R. A., and Dye, S. R., 2018, Internal tides in a dendritic submarine canyon: *Progress in Oceanography*, **169**, p. 20-32. doi:10.1016/j.pocean.2017.10.005
- Bett, B. J., 2001, UK Atlantic margin environmental survey: introduction and overview of bathyal benthic ecology: *Continental Shelf Research*, **21**, p. 917-956.
- Bett, B. J., 2003, Time-lapse photography in the deep sea: *Underwater Technology*, **25**, p. 121-127.
- Bett, B. J., Billett, D. S. M., Masson, D. G., and Tyler, P. A., 2001, RRS Discovery cruise 248 - A multidisciplinary study of the environment and ecology of deep-water coral ecosystems and associated seabed facies and features (The Darwin Mounds, Porcupine Bank and Porcupine Seabight): Southampton Oceanography Centre, 36, 52 p.
- Bett, B. J., Malxone, M. G., Narayanaswamy, B. E., and Wigham, B. D., 2001, Temporal variability in phytodetritus and megabenthic activity at the seabed in the deep Northeast Atlantic: *Progress in Oceanography*, **50**, p. 349-368. doi: 10.1016/S0079-6611(01)00066-0
- Billett, D. S. M., Bett, B. J., Reid, W. D. K., Boorman, B., and Priede, I. G., 2010, Long-term change in the abyssal NE Atlantic: The 'Amperima Event' revisited: *Deep Sea Research II*, **57**, p. 1406-1417. doi:10.1016/j.dsr2.2009.02.001
- Billett, D. S. M., Bett, B. J., Rice, A. L., Thurston, M. H., Galeron, J., Sibuet, M., and Wolff, G. A., 2001, Long-term change in the megabenthos of the Porcupine Abyssal Plain (NE Atlantic). *Progress in Oceanography*, **50**, p. 325-348. doi:10.1016/S0079-6611(01)00060-X
- Billett, D. S. M., Lampitt, R. S., Rice, A. L., and Mantoura, R. F. C., 1983, Seasonal sedimentation of phytoplankton to the deep-sea benthos: *Nature*, **302**, p. 520-522. doi:10.1038/302520a0
- Billett, D. S. M., and Rice, A. L., 2001, The BENGAL programme: introduction and overview. High resolution temporal and spatial study of the benthic biology and geochemistry of a North-Eastern Atlantic abyssal locality (BENGAL): *Progress in Oceanography*, **50**, p. 13-25. doi:10.1016/S0079-6611(01)00046-5
- Bourillet, J. F., Zaragosi, S., and Mulder, T., 2006, The French Atlantic margin and deep-sea submarine systems: *Geo-Marine Letters*, **26**, p. 311-315.
- Brainard, R., Moffitt, R., Timmers, M., Paulay, G., Plaisance, L., Knowlton, N., Caley, J., Fohrer, F., Charette, A., Meyer, C., and Toonen, R., 2009, Autonomous Reef Monitoring Structures (ARMS): A tool for monitoring indices of biodiversity in the Pacific Islands, 11th Pacific Science Inter-Congress: Papeete, Tahiti.
- Carter, G. D. O., Huvenne, V. A. I., Gales, J. A., Lo Iacono, C., Marsh, L., Ougier-Simonin, A., Robert, K., and Wynn, R. B., 2018, Ongoing evolution of submarine canyon rockwalls; examples from the Whittard Canyon, Celtic Margin (NE Atlantic): *Progress in Oceanography*, **169**, p. 79-88. doi: 10.1016/j.pocean.2018.02.001
- Cunningham, M. J., Hodgson, S., Masson, D. G., and Parson, L. M., 2005, An evaluation of along- and down-slope sediment transport processes between Goban Spur and Brenot Spur on the Celtic Margin of the Bay of Biscay: *Sedimentary Geology*, **179**, p. 99-116. doi:10.1016/j.sedego.2005.04.014
- Davies, J. S., Howell, K. L., Stewart, H. A., Guinan, J. C., and Golding, N., 2014, Defining biological assemblages (biotopes) of conservation interest in the submarine canyons of the South West Approaches (offshore United Kingdom) for use in marine habitat mapping: *Deep-Sea Research II*, **104**, p. 208-229.
- Durden, J. M., Bett, B. J., Jones, D. O. B., Huvenne, V. A. I., and Ruhl, H. A., 2015, Abyssal hills -hidden source of increased habitat heterogeneity, benthic megafaunal biomass and diversity in the deep sea: *Progress in Oceanography*, **137**, p. 209-218. doi:10.1016/j.pocean.2015.06.006
- Durden, J. M., Bett, B. J., and Ruhl, H. A., 2020, Subtle variation in abyssal terrain induces significant change in benthic megafaunal abundance, diversity and community structure: *Progress in Oceanography*, **186**, p. 102395. doi:10.1016/j.pocean.2020.102395
- Eggett, A., McBreen, F., Griffiths, Y., van Rein, H., Last, E., and Callaway, A., 2018, CEND0917 cruise report: north-west of Jones Bank and The Canyons Marine Conservation Zones' monitoring survey: JNCC, 58 p.

- Evans, C. D. R., 1990, United Kingdom offshore regional report: the geology of the western English Channel and its western approaches, 93 p.
- Evans, C. D. R., and Hughes, M. J., 1984, The Neogene succession of the south western approaches, Great Britain: *Journal of the Geological Society*, **141**, p. 315-326.
- Hall, R. A., Aslam, T., and Huvenne, V. A. I., 2017, Partly standing internal tides in a dendritic submarine canyon observed by an ocean glider: *Deep Sea Research I*, **126**, p. 73-84. doi:10.1016/j.dsr.2017.05.015
- Hartman, S. E., 2022, Time-series studies at the Porcupine Abyssal Plain Sustained Observatory: National Oceanography Centre, p.
- Hartman, S. E., Bett, B. J., Durden, J. M., Henson, S. A., Iversen, M., Jeffreys, R. M., Horton, T., Lampitt, R., and Gates, A. R., 2021, Enduring science: three decades of observing the Northeast Atlantic from the Porcupine Abyssal Plain Sustained Observatory (PAP-SO): *Progress in Oceanography*, **191**, p. 102508. doi:10.1016/j.pocean.2020.102508
- Heijnen, M. S., Mienis, F., Gates, A. R., Bett, B. J., Hall, R. A., Hunt, J., Kane, I. A., Pebody, C., Huvenne, V. A. I., Soutter, E. L., and Clare, M. A., 2022, Challenging the highstand-dormant paradigm for land-detached submarine canyons: *Nature Communications*, **13**, p. 3488. doi:10.1038/s41467-022-31114-9
- Hopkins, J. E., Stephenson, G. R., Green, J. A. M., Innall, M. E., and Palmer, M. R., 2014, Storms modify baroclinic energy fluxes in a seasonally stratified shelf sea: inertial-tidal interaction: *JGR Oceans*, **119**, p. 6863-6883. doi:10.1002/2014JC010011
- Huffard, C. L., Kuhnz, L. A., Lemon, L., Sherman, A. D., and Smith, K. L., 2016, Demographic indicators of change in a deposit-feeding abyssal holothurian community (Station M, 4000m): *Deep Sea Research I*, **109**, p. 27-39. doi:10.1016/j.dsr.2016.01.002
- Huvenne, V. A. I., and Furlong, M., 2019, RRS James Cook Cruise 166-167, 19 June - 6 July 2018. Haig Fras Marine Conservation Zone AUV habitat monitoring, equipment trials and staff training: National Oceanography Centre, Southampton, 152 p.
- Huvenne, V. A. I., Georgiopoulou, A., Chaumillon, L., Lo Iacono, C., and Wynn, R. B., 2016, Novel method to map the morphology of submarine landslide headwall scarps using remotely operated vehicles, in Lamarche, G., Mountjoy, J., Bull, S., Hubble, T., Krastel, S., Lane, E., Micallef, A., Moscardelli, L., Mueller, C., Pecher, I., and Woelz, S., eds., Submarine mass movements and their consequences, 7th International Symposium, Volume 41: Heidelberg, Springer, p. 135-144.
- Huvenne, V. A. I., and Thornton, B., 2020, RRS Discovery Cruise 108-109. CLASS -Climate-linked Atlantic System Science Darwin Mounds Marine Protected Area habitat monitoring, BioCAM first equipment trials and BLT-Recipes pilot study: National Oceanography Centre, 224 p.
- Huvenne, V. A. I., Tyler, P. A., Masson, D. G., Fisher, E. H., Hauton, C., Hühnerbach, V., Le Bas, T. P., and Wolff, G. A., 2011, A picture on the wall: innovative mapping reveals cold-water coral refuge in submarine canyon: *PLoS One*, **6**, p. e28755. doi: 10.1371/journal.pone.0028755
- Huvenne, V. A. I., Wynn, R. B., and Gales, J. A., 2016, RRS James Cook Cruise 124-125-126. CODEMAP2015: Habitat mapping and ROV vibrocorer trials around Whittard Canyon and Haig Fras: National Oceanography Centre, 149 p.
- Ingels, J., Kiriakoulakis, K., Wolff, G. A., and Vanreusel, A., 2009, Nematode diversity and its relation to quantity and quality of sedimentary organic matter in the Nazare Canyon, Western Iberian Margin: *Deep Sea Research I*, **56**, p. 1521-1539. doi: 10.1016/j.dsr.2009.04.010
- Ingels, J., Tchesunov, A. V., and Vanreusel, A., 2011, Meiofauna in the Gollum Channels and the Whittard Canyon, Celtic Margin - how local environmental conditions shape Nematode structure and function: *PLoS One*, **6**, p. e20094. doi:10.1371/journal.pone.0020094
- JNCC, 2013, The Canyons Marine Conservation Zone - Site Summary Document, 10 p.
- Johnson, M. P., White, M., Wilson, A., Würzberg, L., Schwabe, E., Folch, H., and Allcock, L., 2013, A vertical wall dominated by *Acesta excavata* and *Neopycnodonte zibrowii*, part of an undersampled group of deep-sea habitats: *PLoS One*, **8**, p. e79917. doi:10.1371/journal.pone.0079917
- Lampitt, R. S., and Burnham, M. P., 1983, A free fall time lapse camera and current meter system "Bathysnap" with notes on the foraging behaviour of a bathyal decapod shrimp: *Deep-Sea Research*, **30**, p. 1009-1017.
- Lampitt, R. S., Salter, I., de Cuevas, B. A., Hartman, S., Larkin, K. E., and Pebody, C. A., 2010, Long-term variability of downward particle flux in the deep northeast Atlantic: causes and trends: *Deep Sea Research II*, **57**, p. 1346-1361. doi:10.1016/j.dsr2.2010.01.011
- Lo Iacono, C., Guillen, J., Guerrero, Q., Duran, R., Wardell, C., Hall, R. A., Aslam, T., Carter, G. D. O., Gales, J. A., and Huvenne, V. A. I., 2020, Bidirectional bedform fields at the head of a submarine canyon (NE Atlantic): *Earth and Planetary Science Letters*, **542**, p. 116321. doi:10.1016/j.epsl.2020.116321
- McBreen, F., Askew, N., Cameron, A., Connor, D. W., Ellwood, H., and Carter, A., 2011, UKSeaMap2010: Predictive mapping of seabed habitats in UK waters, 103 p.

- Morris, K. J., Bett, B. J., Durden, J. M., Benoist, N. M. A., Huvenne, V. A. I., Jones, D. O. B., Robert, K., Ichino, M. C., Wolff, G. A., and Ruhl, H. A., 2016, Landscape-scale spatial heterogeneity in phytodetrital cover and megafauna biomass in the abyss links to modest topographic variation: *Scientific Reports*, **6**, p. 34080. doi:10.1038/srep34080
- Morris, K. J., Tyler, P. A., Masson, D. G., Huvenne, V. A. I., and Rogers, A. D., 2013, Distribution of cold-water corals in the Whittard Canyon, NE Atlantic: *Deep-SEa Research II*, **92**, p. 136-144. doi:10.1016/j.dsr2.2013.03.036
- Nash, J. D., Alford, M. H., and Kunze, E., 2005, Estimating internal wave energy fluxes in the ocean: *Journal of Atmospheric and Ocean Technology*, **22**, p. 1551-1570. doi:10.1175/JTECH1784.1
- Ottensen, E., Marin, R., Preston, C., Young, R. C., Ryan, J. P., Scholin, C. A., and DeLong, E. A., 2011, Metatranscriptomic analysis of autonomously collected and preserved bacterioplankton: *The ISME Journal*, **15**, p. 1881-1895.
- Pearman, T. R. R., 2020, Cold-water coral habitat mapping in submarine canyons [Doctor of Philosophy PhD]: University of Southampton, 139 p.
- Pearman, T. R. R., Robert, K., Callaway, A., Hall, R., Lo Iacono, C., and Huvenne, V. A. I., 2020, Improving the predictive capability of benthic species distribution models by incorporating oceanographic data - towards holistic ecological modelling of a submarine canyon: *Progress in Oceanography*, **184**, p. 102338. doi:10.1016/j.pocean.2020.102338
- Pearman, T. R. R., Robert, K., Callaway, A., Hall, R. A., Mienis, F., Lo Iacono, C., and Huvenne, V. A. I., 2023, Spatial and temporal environmental heterogeneity induced by internal tides influences faunal patterns on vertical walls within a submarine canyon: *Frontiers in Marine Science*, **10**, p. 1091855. doi:10.3389/fmars.2023.1091855
- Phillips, A. B., Kingsland, M., Linton, N., Baker, W., Bowring, L., Soper, S., Roper, D. T., Johnson, A., Morrison, R., Ciaramella, K., Matterson, D., Pebody, M., Marlow, R., Consensi, A., Williams, V., Fanelli, F., Fenucci, D., Martin, A., and O'Hobain, E., 2020, Autosub 2000 Under Ice: design of a new work class AUV for under ice expeditions, 2020 IEEE/OES Autonomous Underwater Vehicles Symposium: St Johns, NL, Canada, p. 1-8.
- Porter, M., Innall, M. E., Hopkins, J., Palmer, M. R., Dale, A. C., Aleynik, D., Barth, J. A., Mahaffey, C., and Smeed, D. A., 2016, Glider observations of enhanced deep water upwelling at a shelf break canyon: a mechanism for cross-slope carbon and nutrient exchange: *JGR Oceans*, **121**, p. 7575-7588. doi:10.1002/2016JC012087
- Praeg, D., McCarron, S., Dove, D., O Cofaigh, C., Scott, G., Monteys, X., Facchin, L., Romeo, R., and Coxon, P., 2015, Ice sheet extension to the Celtic Sea shelf edge at the Last Glacial Maximum: *Quaternary Science Reviews*, **111**, p. 107-112. doi:10.1016/j.quascirev.2014.12.010
- Price, D. M., 2021, Multi-scale investigations of cold-water coral habitat using novel technology and advanced image analysis [Doctor of Philosophy PhD]: University of Southampton, 171 p.
- Rice, A. L., Thurston, M. H., and Bett, B. J., 1994, The IOSDL DEEPSEAS Program – Introduction and photographic evidence for the presence and absence of a seasonal input of phytodetritus at contrasting abyssal sites in the Northeastern Atlantic: *Deep Sea Research I*, **41**, p. 1305-1320. doi:10.1016/0967-0637(94)90099-X
- Robert, K., Huvenne, V. A. I., Georgiopolou, A., Jones, D. O. B., Marsh, L., Carter, G. D. O., and Chaumillon, L., 2017, New approaches to high-resolution mapping of marine vertical structures: *Nature Scientific Reports*, **7**, p. 9005. doi:10.1038/s41598-017-09382-z
- Robert, K., Jones, D. O. B., Tyler, P. A., Van Rooij, D., and Huvenne, V. A. I., 2015, Finding the hotspots within a biodiversity hotspot: fine-scale biological predictions within a submarine canyon using high-resolution acoustic mapping techniques: *Marine Ecology*, **36**, p. 1256-1276. doi:10.1111/maec.12228
- Ruhl, H. A., 2013, RRS Discovery Cruise 377 & 378, 05-27 Jul 2012, Southampton to Southampton. Autonomous ecological surveying of the abyss: understanding mesoscale spatial heterogeneity at the Porcupine Abyssal Plain: National Oceanography Centre, 73 p.
- Stewart, H. A., Davies, J. S., Guinan, J. C., and Howell, K. L., 2014, The Dangeard and Explorer Canyons, South-West Approaches, UK: Geology, sedimentology and newly discovered cold-water coral mini-mounds: *Deep-Sea Research II*, **104**, p. 230-244. doi:10.1016/j.dsr2.2013.08.018
- Tchesunov, A. V., Ingels, J., and Popova, E., 2012, Marine free-living nematodes associated with symbiotic bacteria in deep-sea canyons of north-east Atlantic Ocean: *Journal of the Marine Biological Association of the United Kingdom*, **92**, p. 1257-1271. doi: 10.1017/S0025315411002116
- Thiel, H., Pfannkuche, O., Schriever, G., Lochte, K., Gooday, A. J., Hemleben, C., Mantoura, R. F. C., Patching, J. W., Turley, C. M., and Riemann, F., 1989, Phytodetritus on the deep-sea floor in a central oceanic region of the northeast Atlantic: *Biological Oceanography*, **6**, p. 203-239. doi:10.1080/01965581.1988.10749527
- Thurston, M. H., 1986, RRS Challenger Cruise 6A/85 (IOS Cruise 522): 13-28 June 1985. Benthic biology of the Porcupine Seabight: Institute of Oceanographic Sciences, 36 p.
- Toucanne, S., Zaragosi, S., Bourillet, J.-F., Naughton, F., Cremer, M., Eynaud, F., and Dennielou, B., 2008, Activity of the turbidite levees of the Celtic-Armorican margin (Bay of Biscay) during the last 30,000 years: imprints

- of the last European deglaciation and Heinrich events: *Marine Geology*, **247**, p. 84-103. doi:10.1016/j.margeo.2007.08.006
- Van Gaever, S., Moodley, L., de Beer, D., and Vanreusel, A., 2006, Meiobenthos at the Arctic Håkon Mosby Mud Volcano, with a parental-caring nematode thriving in sulphide-rich sediments: *Marine Ecology Progress Series*, **321**, p. 143-155. doi: 10.3354/meps321143
- Vlasenko, V., Stashchuk, N., Innall, M. E., Porter, M., and Aleynik, D., 2016, Focusing of baroclinic tidal energy in a canyon: *JGR Oceans*, **121**, p. 2824-2840. doi:10.1002/2015JC011314
- Warner, A., and Hays, G., 1994, Sampling by the continuous plankton recorder survey: *Progress in Oceanography*, **34**, p. 237-256.
- Wilson, A. M., Kiriakoulakis, K., Raine, R., Gerritsen, H. D., Blackbird, S., Allcock, A. L., and White, M., 2015, Anthropogenic influence on sediment transport in the Whittard Canyon, NE Atlantic: *Marine Pollution Bulletin*, **101**, p. 320-329. doi:10.1016/j.marpolbul.2015.10.067
- Wood, S., Biessey, L., Latchford, J., Zaiko, A., von Ammon, U., Audrezet, F., Cristescu, M., and Pochon, X., 2020, Release and degradation of environmental DNA and RNA in a marine system: *Science of the Total Environment*, **704**, p. 135314. doi:10.1016/j.scitotenv.2019.135314
- Zaragosi, S., Auffret, G. A., Faugères, J. C., Garlan, T., Pujol, C., and Cortijo, E., 2000, Physiography and recent sediment distribution of the Celtic Deep-Sea Fan, Bay of Biscay: *Marine Geology*, **169**, p. 207-237.
- Zaragosi, S., Bourillet, J.-F., Eynaud, F., Toucanne, S., Denhard, B., Van Toer, A., and Lanfume, V., 2006, The impact of the last European deglaciation on the deep-sea turbidite systems of the Celtic-Armorican margin (Bay of Biscay): *Geo-Marine Letters*, **26**, p. 317-329. DOI 10.1007/s00367-006-0048-9

9. STATION LIST

Site	Final sample number	JDay	Start Date	Start Time	Start Lat	Start Lat Min	Start Long Degr	Start Long	Start Waterdept	Equipm ent	Jday	End Date	End Time	End Lat	End Lat Min	End Lon	End Long	End waterd epth	Comments	Recipient
Whittard Canyon	DY152-000-BSNAP-Trial/																			
Whittard Canyon	JC237-001-CPR01/	218	06/08/2022	13:03:00	50	35.9900	1	0.3300			220	08/08/2022	10:07:00	47	52.3830	10	10.1920	4069		
Whittard Canyon	JC237-002-CTD001/	220	08/08/2022	01:13:00	47	53.6100	10	10.3800	4030.0	4000.0	220	08/08/2022	12:19:00	47	56.8550	10	7.7000	3714.0		
Whittard Canyon	JC237-003-AUV31/	220	08/08/2022	15:39:00	48	15.3580	9	41.8400	516.0		221	09/08/2022	09:19:00	48	16.9500	9	39.9400		Aborted early - too close to seafloor	NOCS
Whittard Canyon	JC237-004-MGC01/	220	08/08/2022	17:42:00	48	18.5000	9	40.9000	479.0	493.0									8 successful cores	
Whittard Canyon	JC237-005-MGC02/	220	08/08/2022	20:05:00	48	24.3091	9	43.5597	497.0	496.0									Failed - empty	
Whittard Canyon	JC237-006-ROV382/	221	09/08/2022	10:20:10	48	16.2200	9	37.9250	315.0		221	09/08/2022	14:04:00	48	16.3740	9	38.2470	323.0		
Whittard Canyon	JC237-006-ROV382/EXP01	221	09/08/2022	12:23:00	48	16.5980	9	38.3650	332.0	332.0									deploy tile house	NOCS
Whittard Canyon	JC237-006-ROV382/EXP02	221	09/08/2022	12:29:00	48	16.5970	9	38.3680	332.0	332.0									deploy flats	NOCS / NUIG
Whittard Canyon	JC237-006-ROV382/NSK01	221	09/08/2022	12:33:00	48	16.5970	9	38.3680	332.0	332.0									fire large niskin	NOCS - OTE
Whittard Canyon	JC237-006-ROV382/NSK02	221	09/08/2022	12:53:00	48	16.6200	9	38.1920	334.0	334.0									fire 6x small niskins	NOCS-OTE
Whittard Canyon	JC237-007-AUV32/	221	09/08/2022	14:39:00	48	16.0740	9	39.6530	377.0		221	09/08/2022	19:37:00	48	15.7435	9	38.3371	348.0	Early return on second to last line	NOCS
Whittard Canyon	JC237-008-CTD002/	221	09/08/2022	16:00:00	48	15.5936	9	40.4335	425.0	420.0	221	09/08/2022	16:36:00	48	15.5931	9	40.4326	422.0		UEA
Whittard Canyon	JC237-009-ROV383/	221	09/08/2022	21:42:00	48	28.1180	9	38.9140			222	10/08/2022	11:23:00	48	28.6660	9	39.3194			
Whittard Canyon	JC237-009-ROV383/NSK01	222	10/08/2022	00:27:00	48	28.1047	9	38.8753	1063.5	1063.5									All small Niskins fired	NOCS - OTE
Whittard Canyon	JC237-009-ROV383/PSH01	222	10/08/2022	01:36:00	48	28.1123	9	38.8214	1061.0	1061.0	222	10/08/2022							3 yellow stripe core, successful	NOCS - MG
Whittard Canyon	JC237-009-ROV383/PSH02	222	10/08/2022	01:38:00	48	28.1123	9	38.8214	1061.0	1061.0	222	10/08/2022							3 blue stripe push core - broke tube	NOCS - MG
Whittard Canyon	JC237-009-ROV383/PSH03	222	10/08/2022	02:51:00	48	28.1380	9	38.9400	1073.7	1073.7	222	10/08/2022							2 blue stripe push core - failed very stiff clay	NOCS - MG
Whittard Canyon	JC237-009-ROV383/PSH04	222	10/08/2022	03:14:00	48	28.1612	9	38.9633	1062.2	1062.2	222	10/08/2022							2 yellow stripe push core - loose sediment	
Whittard Canyon	JC237-009-ROV383/RCK01	222	10/08/2022	03:37:00	48	28.1726	9	39.0191	1049.0	1049.0	222	10/08/2022							fell from tube. Underlying stiff clay	NOCS - MG
Whittard Canyon	JC237-009-ROV383/RCK02	222	10/08/2022	05:58:00	48	28.3536	9	39.2520	935.0	935.0	222	10/08/2022							Clay Rock in front biobox	OGS
Whittard Canyon	JC237-009-ROV383/PTG01	222	10/08/2022	06:58:00	48	28.4560	9	39.3980	867.0	867.0	222	10/08/2022							Blocky grey mudstone in aft biobox	BGS
Whittard Canyon	JC237-009-ROV383/NSK02	222	10/08/2022	08:00:00	48	28.4900	9	39.3170	864.0	864.0	222	10/08/2022							Photogrammetry of coral mound	NOCS
Whittard Canyon	JC237-009-ROV383/TBE01	222	10/08/2022	10:06:00	48	28.6660	9	39.3630	784.0	784.0	222	10/08/2022							Big Niskin fired successfully	NOCS - OTE
Whittard Canyon	JC237-009-ROV383/TBE02	222	10/08/2022	10:15:00	48	28.6660	9	39.3630	784.0	784.0	222	10/08/2022							Desmophyllum pertusum (orange in the 12)	USoton
Whittard Canyon	JC237-010-AUV33/	222	10/08/2022	13:32:00	48	45.7980	9	49.3580	184.0		223	11/08/2022	13:27:00	48	45.5000	9	49.7660	190.0	Desmophyllum pertusum (white in the 9)	USoton
Whittard Canyon	JC237-011-MGC03/	222	10/08/2022	16:39:00	48	24.9300	9	43.6200	538.0										timed out before mission end	NOCS
Whittard Canyon	JC237-012-ROV384/	222	10/08/2022	18:54:00	48	27.7720	9	39.2450			223	11/08/2022	09:10:00	48	28.2460	9	39.9680	819.0	8 successful cores	
Whittard Canyon	JC237-012-ROV384/DRL01	222	10/08/2022	21:08:00	48	27.6860	9	39.3890	1071.1	1071.1									Rock drill sample stuck in drill	OGS/BGS
Whittard Canyon	JC237-012-ROV384/RCK01	222	10/08/2022	21:57:00	48	27.6840	9	39.3780	1070.6	1070.6									Whitish rock. In front biobox	BGS/OGS
Whittard Canyon	JC237-012-ROV384/RCK02	222	10/08/2022	22:04:00	48	27.6840	9	39.3780	1070.6	1070.6									Shell and coral debris in front biobox	NOCS
Whittard Canyon	JC237-012-ROV384/RCK03	222	10/08/2022	22:35:00	48	27.6530	9	39.3500	1050.0	1050.0									Piece of loose rock from whitish formation, in core basket location 2	BGS/OGS
Whittard Canyon	JC237-012-ROV384/RCK04	222	10/08/2022	22:35:00	48	27.6530	9	39.3500	1050.0	1050.0									Piece of loose rock from whitish formation, in core basket blue box	BGS/OGS
Whittard Canyon	JC237-012-ROV384/NSK01	223	11/08/2022	06:49:00	48	28.3100	9	39.9650	839.0	839.0									6 small niskin fired above cwc mound	NOCS - OTE
Whittard Canyon	JC237-012-ROV384/NSK02	223	11/08/2022	07:02:00	48	28.3050	9	39.9570	830.0	830.0									1 large niskin fired above cwc mound	NOCS - OTE
Whittard Canyon	JC237-012-ROV384/BIOB01	223	11/08/2022	07:48:00	48	28.3040	9	39.9710	843.0	843.0									White live desmophyllum sample in front biobox	USoton
Whittard Canyon	JC237-012-ROV384/BIOB02	223	11/08/2022	07:58:00	48	28.3040	9	39.9710	843.0	843.0									Orange live desmophyllum sample in rear biobox	USoton
Whittard Canyon	JC237-013-CTD003/	223	11/08/2022	14:51:00	48	40.8870	10	3.3859	1181.0	1194.0										UEA
Whittard Canyon	JC237-014-ROV385/	223	11/08/2022	18:20:01	48	39.2579	10	1.9324	1334.0		224	12/08/2022	09:35:00	48	39.1021	10	1.1781	1203.0		
Whittard Canyon	JC237-014-ROV385/PSH01	223	11/08/2022	23:18:00	48	39.3837	10	1.3817	1272.1	1272.1									sed core for sed - full	NOCS - MG
Whittard Canyon	JC237-014-ROV385/PSH02	223	11/08/2022	23:20:30	48	39.3837	10	1.3817	1272.1	1272.1									1/2 full leaking sed orgc (sed surface intact)	NOCS - OTE
Whittard Canyon	JC237-014-ROV385/PSH03	223	11/08/2022	23:52:00	48	39.3850	10	1.2740	1242.5	1242.5									biology Xeno	NOCS
Whittard Canyon	JC237-014-ROV385/PSH04	223	11/08/2022	23:55:00	48	39.3830	10	1.2748	1242.5	1242.5									orgc sed surface intact edna	NOCS - OTE
Whittard Canyon	JC237-014-ROV385/PSH05	224	12/08/2022	01:56:00	48	39.4300	10	0.8162	1121.9	1121.9									orgc sed surface intact edna	NOCS - OTE
Whittard Canyon	JC237-014-ROV385/PSH06	224	12/08/2022	02:03:00	48	39.4480	10	0.8484	1121.9	1121.9									sed - sed surface intact	NOCS - MG
Whittard Canyon	JC237-014-ROV385/PSH07	224	12/08/2022	06:33:00	48	39.2250	10	0.9850	1200.4	1200.4									sed - sed surface intact	NOCS - MG
Whittard Canyon	JC237-014-ROV385/PSH08	224	12/08/2022	06:57:00	48	39.2250	10	0.9850	1200.2	1200.2									maybe most fell out - orgc - edna	NOCS - MG
Whittard Canyon	JC237-014-ROV385/PSH09	224	12/08/2022	07:44:00	48	39.3220	10	0.9230	1154.1	1154.1									sed - sed surface intact	NOCS - MG
Whittard Canyon	JC237-014-ROV385/PSH10	224	12/08/2022	08:00:00	48	39.3240	10	0.9220	1154.0	1154.0									edna	NOCS - MG
Whittard Canyon	JC237-015-CTD004/	224	12/08/2022	10:30:00	48	39.1699	10	2.1243	1296.0	1294.0	224	12/08/2022	13:05:00	48	39.2244	10	2.1755	1290.0		
Whittard Canyon	JC237-015-CTD004/SAPS01	224	12/08/2022	11:13:00	48	39.1986	10	2.1525	1294.0	1294.0	224	12/08/2022	12:13:00	48	39.2185	10	2.1690	1299.0	SAPS close to coral wall 461 litres pumped	JMUL
Whittard Canyon	JC237-016-AUV34/	224	12/08/2022	15:30:00	48	29.8400	9	37.3820	707.0		225	13/08/2022	12:03:00	48	39.7130	9	39.2260	330.0		

Site	Final sample number	JDay Start	Start Date	Start Time GMT	Start Lat Deg N	Start Lat Min N	Start Long Degr W	Start Long Min W	Start Waterdept h meter	Equipm ent depth	Jday End	End Date	End Time GMT	End Lat Degr	End Lat Min	End Lon Deg	End Lon Min	End Long m	End waterd e pth (m)	Comments	Recipient
Whittard Canyon	JC237-017-ROV386/	224	12/08/2022	18:30:00	48 20.5260		9 41.3237		1361.0		225	13/08/2022	10:33:00	48 21.6480		9 43.4400		650.0			
Whittard Canyon	JC237-017-ROV386/RCK01	225	13/08/2022	00:23:00	48 20.6140		9 42.8930		1344.5	1344.5										white carbonate rock - hard	BGS/OGS
Whittard Canyon	JC237-017-ROV386/RCK02	225	13/08/2022	00:24:00	48 20.6140		9 42.8930		1344.5	1344.5										white carbonate rock - fragile	BGS/OGS
Whittard Canyon	JC237-017-ROV386/PSH01	225	13/08/2022	01:14:00	48 20.6680		9 42.8820		1296.5	1296.5										sed	NOCS - MG
Whittard Canyon	JC237-017-ROV386/PSH02	225	13/08/2022	01:17:00	48 20.6710		9 42.8820		1296.6	1296.6										orgc/edna	NOCS - OTE
Whittard Canyon	JC237-017-ROV386/PSH03	225	13/08/2022	01:22:00	48 20.6700		9 42.8800		1296.6	1296.6										rock' sample	BGS/OGS
Whittard Canyon	JC237-017-ROV386/PSH04	225	13/08/2022	02:05:00	48 20.7960		9 42.8690		1181.9	1181.9										orgc/edna	NOCS - OTE
Whittard Canyon	JC237-017-ROV386/PSH05	225	13/08/2022	02:07:00	48 20.7960		9 42.8690		1182.0	1182.0										sed	NOCS - MG
Whittard Canyon	JC237-017-ROV386/PSH06	225	13/08/2022	02:10:00	48 20.7960		9 42.8690		1181.9	1181.9										rock' sample	BGS/OGS
Whittard Canyon	JC237-017-ROV386/NSK01	225	13/08/2022	03:43:00	48 21.0960		9 42.9560		1153.3	1153.3										Large niskin fired	NOCS - OTE
Whittard Canyon	JC237-017-ROV386/RCK03	225	13/08/2022	03:53:00	48 21.0960		9 42.9560		1153.1	1153.1										rock - broke up in claw some fell in fwd bio	BGS/OGS
Whittard Canyon	JC237-017-ROV386/NSK02	225	13/08/2022	09:11:00	48 21.7210		9 43.3610		650.0	696.0										bottles 4 & 5 only	NOCS - OTE
Whittard Canyon	JC237-018-ROV387/	225	13/08/2022	19:25:00	48 45.7950		10 27.6350		745.0		226	14/08/2022	10:28:00	48 45.7800		10 27.7210		738.0			
Whittard Canyon	JC237-018-ROV387/PSH01	225	13/08/2022	20:41:00	48 45.6830		10 27.5400		751.5	751.5										PSH3 red - right hand core rack, 3/4 full	
Whittard Canyon	JC237-018-ROV387/PSH02	225	13/08/2022	20:44:00	48 45.6830		10 27.5400		751.5	751.5										PSH3 blue - right hand rack, 1/2-3/4 full	
Whittard Canyon	JC237-018-ROV387/RCK01	225	13/08/2022	21:10:00	48 45.6570		10 27.4390		707.5	707.5										Large rock with some biological turf	
Whittard Canyon	JC237-018-ROV387/NSK01	226	14/08/2022	01:47:00	48 45.5600		10 27.5190		686.7	686.7										Large niskin, top of acesa wall	
Whittard Canyon	JC237-018-ROV387/PSH03	226	14/08/2022	02:24:00	48 45.5420		10 27.4620		550.7	550.7										PSH 2 yellow, note 2 cores with 2 yellow stripes, this one slot 4	
Whittard Canyon	JC237-018-ROV387/PSH04	226	14/08/2022	02:28:00	48 45.5420		10 27.4620		550.7	550.7										PSH3 blue left hand core rack	
Whittard Canyon	JC237-018-ROV387/PSH05	226	14/08/2022	04:09:00	48 45.6046		10 27.4420		761.0	761.0										Yellow 2, left box mid right - 1/2 full	
Whittard Canyon	JC237-018-ROV387/PSH06	226	14/08/2022	04:16:00	48 45.6042		10 27.4681		761.0	761.0										blue 2, 1/2 full left box mid left	
Whittard Canyon	JC237-018-ROV387/PSH07	226	14/08/2022	04:58:00	48 45.6261		10 27.6826		761.0	761.0										blue 1 - very short if any, left box rear left	
Whittard Canyon	JC237-018-ROV387/PSH08	226	14/08/2022	05:14:00	48 45.6272		10 27.6835		761.0	761.0										yellow 1 - v. short if any, left box rear right	
Whittard Canyon	JC237-018-ROV387/PSH09	226	14/08/2022	06:15:00	48 45.6880		10 27.7904		756.0	756.0										blue 2, short but ok. Blue 2 right box mid	
Whittard Canyon	JC237-018-ROV387/NSK02	226	14/08/2022	08:22:00	48 45.8710		10 27.6250		560.0	560.0										small niskins near acesa, all 6 fires	
Whittard Canyon	JC237-018-ROV387/BIOB01	226	14/08/2022	09:25:00	48 45.8440		10 27.7680		545.0	545.0										large orange lophelia in fwd bio box	
Whittard Canyon	JC237-018-ROV387/BIOB02	226	14/08/2022	09:29:00	48 45.8440		10 27.7680		545.0	545.0										white lophelia fell into tool sled	
Whittard Canyon	JC237-019-AUV35/	226	14/08/2022	11:14:00	48 45.3560		10 26.1750				227	15/08/2022	08:42:00	48 44.6420		10 31.4040		528.0		AUV aborted mission - was sent to meet ship and stay close until ROV dive finished	NOCS
Whittard Canyon	JC237-020-GC01/	226	14/08/2022	13:04:00	48 48.7999		10 33.1886		965.0												NOCS - MG
Whittard Canyon	JC237-021-GC02/	226	14/08/2022	14:40:00	48 48.7199		10 32.7286		953.0											80m/min, 1.9 T pull-out.	NOCS - MG
Whittard Canyon	JC237-022-ROV388/	226	14/08/2022	16:27:00	48 42.6760		10 32.2710		1344.0		227	15/08/2022	07:20:00	48 43.2384		10 32.1582		1015.0			
Whittard Canyon	JC237-022-ROV388/PSH01	226	14/08/2022	18:21:00	48 42.6630		10 32.0830		1335.0	1335.0										seeds	
Whittard Canyon	JC237-022-ROV388/PSH02	226	14/08/2022	18:23:00	48 42.6630		10 32.0830		1335.0	1335.0										oc/edna	
Whittard Canyon	JC237-022-ROV388/PSH03	226	14/08/2022	20:01:00	48 42.5350		10 31.9570		1172.5	1172.5										seeds	
Whittard Canyon	JC237-022-ROV388/PSH04	226	14/08/2022	20:10:00	48 42.5390		10 31.9510		1171.6	1171.6										oc/edna	
Whittard Canyon	JC237-022-ROV388/RCK01	226	14/08/2022	21:13:00	48 42.4500		10 32.1190		1225.0	1225.0										loose piece but clearly coming from the wall behind	
Whittard Canyon	JC237-022-ROV388/NSK01	226	14/08/2022	22:18:00	48 42.4040		10 32.0780		1114.0	1114.0										large niskin - delay in recording depth	
Whittard Canyon	JC237-022-ROV388/PSH05	226	14/08/2022	22:34:00	48 42.3680		10 32.0940		1099.0	1099.0										seeds	
Whittard Canyon	JC237-022-ROV388/PSH06	226	14/08/2022	22:36:00	48 42.3670		10 32.0960		1090.0	1090.0										for rock analysis	
Whittard Canyon	JC237-022-ROV388/RCK02	227	15/08/2022	00:08:00	48 42.7290		10 31.9400		1204.0	1204.0										black dark rock not in situ (just to check lithology)	
Whittard Canyon	JC237-022-ROV388/PSH07	227	15/08/2022	00:47:00	48 42.7790		10 31.8780		1256.0	1256.0										oc/edna	
Whittard Canyon	JC237-022-ROV388/PSH08	227	15/08/2022	00:51:00	48 42.7790		10 31.8770		1256.0	1256.0										seeds	
Whittard Canyon	JC237-023-CTD005/	227	15/08/2022	09:45:00	48 45.5594		10 27.5820		764.0	662.0	227	15/08/2022	11:53:00	48 45.5615		10 27.5812		763.0			
Whittard Canyon	JC237-023-CTD005/SAPS02	227	15/08/2022	10:19:00	48 45.5618		10 27.5819		763.0	662.0	227	15/08/2022	11:19:00	48 45.5607		10 27.5812		662.0		SAPS pumped 735 l	JMUL
Whittard Canyon	JC237-024-GC03/	227	15/08/2022	16:38:00	48 45.6593		9 55.8252		2018.0											Failed fell over	NOCS - MG
Whittard Canyon	JC237-025-GC04/	227	15/08/2022	18:55:00	48 30.9160		9 56.0370		2176.0											Failed - core catcher failed	NOCS - MG
Whittard Canyon	JC237-026-GC05/	227	15/08/2022	20:54:00	48 30.9160		9 56.0390		2190.0											Success 0.7m	NOCS - MG
Whittard Canyon	JC237-027-GC06/	229	17/08/2022	09:41:00	48 31.7770		9 56.1640		2098.0	2085.0										Successful - full tube 3m core	NOCS - MG
Whittard Canyon	JC237-028-AUV36/	229	17/08/2022	14:04:00	48 46.0630		10 27.2120		Not recorded		229	17/08/2022	16:05:00	48 44.8930		10 28.4281				A5 aborted 1 hour into mission	NOCS
Whittard Canyon	JC237-029-AUV37/	229	17/08/2022	17:21:00	48 45.6310		10 28.1640		601.0		230	18/08/2022	10:49:00	48 44.1160		10 30.3730		923.0		Mission had several sections	NOCS
Whittard Canyon	JC237-030-ROV389/	229	17/08/2022	19:07:39	48 45.2896		10 37.7335		1306.0		230	18/08/2022	09:23:00	48 46.4050		10 38.3920		750.0			
Whittard Canyon	JC237-030-ROV389/PSH01	229	17/08/2022	21:02:00	48 45.2950		10 37.7360		1322.0	1322.0										OC	NOCS - OTE
Whittard Canyon	JC237-030-ROV389/PSH02	229	17/08/2022	21:05:00	48 45.2950		10 37.7360		1322.0	1322.0										SEDS	NOCS - MG

Site	Final sample number	JDay Start	Start Date	Start Time GMT	Start	Start	Start	Start	Equipm ent depth	Jday End	End Date	End Time GMT	End	End	End	End	Comments	Recipient	
					Lat Deg N	Lat Min N	Long Degr W	Long Min W					Waterdept h meter	Lat Degr	Lat Min	Lon Deg			Lon Min
Whittard Canyon	JC237-030-ROV389/NSK01	230	18/08/2022	05:52:00	48 46.2270		10 38.3500		850.0	850.0							small niskin fired near seapens aggregations	NOCS - OTE	
Whittard Canyon	JC237-030-ROV389/PSH03	230	18/08/2022	06:45:00	48 46.5100		10 38.4890		802.0	802.0							Nematode sampling	J Ingels	
Whittard Canyon	JC237-030-ROV389/PSH04	230	18/08/2022	06:50:00	48 46.5100		10 38.4890		802.0	802.0							Nematode sampling	J Ingels	
Whittard Canyon	JC237-030-ROV389/PSH05	230	18/08/2022	06:58:00	48 46.5100		10 38.4890		802.0	802.0							Nematode sampling	J Ingels	
Whittard Canyon	JC237-030-ROV389/PSH06	230	18/08/2022	07:27:00	48 46.5180		10 38.5120		795.0	795.0							Nematode sampling	J Ingels	
Whittard Canyon	JC237-030-ROV389/PSH07	230	18/08/2022	07:32:00	48 46.5180		10 38.5120		795.0	795.0							Nematode sampling	J Ingels	
Whittard Canyon	JC237-030-ROV389/PSH08	230	18/08/2022	07:39:00	48 46.5180		10 38.5120		795.0	795.0							Nematode sampling	J Ingels	
Whittard Canyon	JC237-030-ROV389/PSH09	230	18/08/2022	08:10:00	48 46.4767		10 38.5202		821.5	821.5							Nematode sampling	J Ingels	
Whittard Canyon	JC237-030-ROV389/PSH10	230	18/08/2022	08:12:00	48 46.4767		10 38.5202		821.5	821.5							Nematode sampling	J Ingels	
Whittard Canyon	JC237-030-ROV389/PSH11	230	18/08/2022	08:15:00	48 46.4767		10 38.5202		821.5	821.5							Nematode sampling	J Ingels	
Whittard Canyon	JC237-030-ROV389/PSH12	230	18/08/2022	08:19:00	48 46.4767		10 38.5202		821.5	821.5							Nematode sampling	J Ingels	
Whittard Canyon	JC237-030-ROV389/NSK02	230	18/08/2022	08:23:00	48 46.4767		10 38.5202		821.5	821.5							Large Niskin	NOCS - OTE	
Whittard Canyon	JC237-031-AUV38/	230	18/08/2022	13:33:00	48 46.0260		10 27.4670		713.0		230	18/08/2022	16:13:00	48 45.1387		10 27.9182	674.0		NOCS
Whittard Canyon	JC237-032-GC07/	230	18/08/2022	19:46:00	48 31.7600		9 56.2500		2112.0	2112.0							wire-out = 2112m, pull-out = 2.04T, 50m/min, hit stiff sandy clay with gravel. Time/location is core on bottom	NOCS - MG	
Whittard Canyon	JC237-033-MGC04/	230	18/08/2022	22:03:00	48 31.7650		9 56.1680		2124.0	2100.0							6 tubes full. Pull-out = 2.7 T, wire-out = 2100. Time/location for core on bottom	NOCS - MG	
Whittard Canyon	JC237-034-CTD006/	231	19/08/2022	06:10:00	48 23.8649		9 50.1347		2050.0	1978.0	231	19/08/2022	07:30:00	48 23.8666		9 50.1397	50.0		UEA
Whittard Canyon	JC237-034-CTD007/	232	19/08/2022	07:32:00	48 23.8666		9 50.1397		2077.0	1976.0	231	19/08/2022	08:43:00	48 23.8653		9 50.1277	51.0		UEA
Whittard Canyon	JC237-034-CTD008/	233	19/08/2022	08:46:00	48 23.8674		9 50.1254		2079.0	1976.0	231	19/08/2022	10:01:00	48 23.8644		9 50.1379	52.0		UEA
Whittard Canyon	JC237-034-CTD009/	234	19/08/2022	10:03:00	48 23.8644		9 50.1379		2077.0	1979.0	231	19/08/2022	11:30:00	48 23.8676		9 50.1337	50.0		UEA
Whittard Canyon	JC237-034-CTD010/	235	19/08/2022	11:32:00	48 23.8676		9 50.1337		2072.0	1977.0	231	19/08/2022	13:38:00	48 23.8744		9 50.1212	51.0		UEA
Whittard Canyon	JC237-034-CTD011/	236	19/08/2022	13:46:00	48 23.8743		9 50.1200		2067.0	1975.0	231	19/08/2022	15:38:00	48 23.8810		9 50.1135	52.0		UEA
Whittard Canyon	JC237-034-CTD012/	237	19/08/2022	15:41:00	48 23.8810		9 50.1135		2064.0	1974.0	231	19/08/2022	17:11:00	48 23.8810		9 50.1137	0.0		UEA
Whittard Canyon	JC237-034-CTD013/	238	19/08/2022	17:15:00	48 23.8810		9 50.1137		2067.0	1966.0	231	19/08/2022	18:59:00	48 23.8813		9 50.1143	0.0		UEA
Whittard Canyon	JC237-035-ROV390/	231	19/08/2022	20:06:00	48 24.7368		9 49.9506		1631.0		232	20/08/2022	11:20:30	48 24.4530		9 50.3750	1800.0		
Whittard Canyon	JC237-035-ROV390/PSH01	231	19/08/2022	23:45:00	48 24.9260		9 50.1170		1599.0	1599.0							Lipids	NOCS - MG	
Whittard Canyon	JC237-035-ROV390/PSH02	231	19/08/2022	23:49:00	48 24.9260		9 50.1170		1599.0	1599.0							SEDS	NOCS - MG	
Whittard Canyon	JC237-035-ROV390/PSH03	231	19/08/2022	23:52:00	48 24.9260		9 50.1190		1599.0	1599.0							OC/Edna	NOCS - MG	
Whittard Canyon	JC237-035-ROV390/NSK01	232	20/08/2022	00:15:00	48 24.9470		9 50.1180		1492.0	1492.0							Large Niskin	NOCS - OTE	
Whittard Canyon	JC237-035-ROV390/PSH04	232	20/08/2022	03:06:00	48 24.4930		9 50.0780		1957.0	1957.0							SEDS	NOCS - MG	
Whittard Canyon	JC237-035-ROV390/PSH05	232	20/08/2022	03:08:00	48 24.4930		9 50.0780		1957.0	1957.0							OC/Edna	NOCS - MG	
Whittard Canyon	JC237-035-ROV390/PSH06	232	20/08/2022	03:10:00	48 24.4930		9 50.0780		1957.0	1957.0							SEDS	NOCS - MG	
Whittard Canyon	JC237-035-ROV390/NSK02	232	20/08/2022	06:12:00	48 24.5887		9 49.5565		1609.0	1609.0							6 small niskins near fan sponge and soft coral agr.	NOCS - OTE	
Whittard Canyon	JC237-035-ROV390/PSH07	232	20/08/2022	08:00:00	48 24.5290		9 50.1911		1899.0	1899.0							SEDS	NOCS - MG	
Whittard Canyon	JC237-035-ROV390/PSH10	232	20/08/2022	08:10:00	48 24.5290		9 50.1911		1899.0	1899.0							OC/Edna	NOCS - MG	
Whittard Canyon	JC237-036-GC08	232	20/08/2022	13:16:00	48 31.7745		9 56.0425		2080.0	2047.0							260 cm recovered. Depth is max wire out. EM120 2080 m WD. Pull-out = 2.6T	NOCS - MG	
Whittard Canyon	JC237-037-AUV39	232	20/08/2022	15:57:00	48 24.7235		9 40.8897		367.0		233	21/08/2022	11:40:00	48 23.4224		9 43.1230	317.0		NOCS
Whittard Canyon	JC237-038-ROV391/	232	20/08/2022	19:05:44	48 38.1684		10 0.8984		1535.0		233	21/08/2022	09:01:00	48 39.7960		9 59.8830	407.0		
Whittard Canyon	JC237-038-ROV391/PSH01	232	20/08/2022	20:58:00	48 38.1680		10 0.9470		1546.0	1546.0							OC/Edna	NOCS - MG	
Whittard Canyon	JC237-038-ROV391/PSH02	232	20/08/2022	21:03:00	48 38.1690		10 0.9460		1546.0	1546.0							SEDS	NOCS - MG	
Whittard Canyon	JC237-038-ROV391/PSH03	232	20/08/2022	23:44:00	48 38.2130		10 1.4140		1360.0	1360.0							OC/Edna	NOCS - MG	
Whittard Canyon	JC237-038-ROV391/PSH04	232	20/08/2022	23:49:00	48 38.2130		10 1.4140		1360.0	1360.0							SEDS	NOCS - MG	
Whittard Canyon	JC237-038-ROV391/PSH05	233	21/08/2022	00:35:00	48 38.1585		10 1.4880		1303.0	1303.0							OC/Edna	NOCS - MG	
Whittard Canyon	JC237-038-ROV391/PSH06	233	21/08/2022	00:37:00	48 38.1604		10 1.4880		1303.0	1303.0							SEDS	NOCS - MG	
Whittard Canyon	JC237-038-ROV391/PSH07	233	21/08/2022	03:05:00	48 38.1274		10 0.1904		1259.0	1259.0							OC/Edna	NOCS - MG	
Whittard Canyon	JC237-038-ROV391/PSH08	233	21/08/2022	03:06:02	48 38.1271		10 0.1904		1259.0	1259.0							SEDS	NOCS - MG	
Whittard Canyon	JC237-038-ROV391/PSH09	233	21/08/2022	04:34:00	48 38.2423		10 0.2517		1253.0	1253.0							SEDS	NOCS - MG	
Whittard Canyon	JC237-038-ROV391/PSH10	233	21/08/2022	04:39:00	48 38.2424		10 0.2512		1253.0	1253.0							OC/Edna	NOCS - MG	
Whittard Canyon	JC237-038-ROV391/PSH11	233	21/08/2022	07:21:00	48 38.5900		9 59.9274		1062.0	1062.0							SEDS	NOCS - MG	
Whittard Canyon	JC237-038-ROV391/PSH12	233	21/08/2022	07:27:00	48 38.5934		9 59.9533		1062.0	1062.0							OC/Edna	NOCS - MG	
Whittard Canyon	JC237-039-CTD014/	233	21/08/2022	13:37:00	48 31.7690		9 56.1760		2122.0	2028.0	233	21/08/2022	16:29:00	48 31.7640		9 56.1710	2121.0	Plus SAPS 3	UEA
Whittard Canyon	JC237-039-CTD014/SAPS03	233	21/08/2022	14:40:00	48 31.7500		9 56.1790		2122.0	2028.0	233	21/08/2022	15:40:00	48 31.7630		9 56.1750	2028.0	volume pumped 667	JMUL

Site	Final sample number	JDay	Start Date	Start Time GMT	Start	Start	Start	Start	Equipm ent	Jday	End Date	End Time GMT	End	End	End	End	Comments	Recipient
					Lat Deg	Lat Min N	Long Degr W	Long Min W					Waterdept h meter	Lat Deg	End Lat Min	Lon Deg		
Whittard Canyon	JC237-040-CTD015/	233	21/08/2022	18:27:00	48 39.1600	10 2.0900	1291.0	1305.0		233	21/08/2022	19:50:00	48 39.1630	10 2.1230	1289.0		~100m off bottom	UEA
Whittard Canyon	JC237-041-CTD016/	233	21/08/2022	20:52:00	48 43.9810	10 5.9040	899.0	873.0		233	21/08/2022	22:05:00	48 43.8910	10 5.9050	901.0			UEA
Whittard Canyon	JC237-042-GC09/	234	22/08/2022	00:54:00	48 35.8400	9 58.0400	1626.0										Empty barrel, stiff sandy clay in core catcher. Wire out 1658, pull out 1.85T, time/location on bottom	NOCS - MG
Whittard Canyon	JC237-043-AUV40/	234	22/08/2022	08:55:59	48 39.7110	10 1.5800	142.6			235	23/08/2022	12:33:15	48 41.7300	10 1.7136	445.0			NOCS
Whittard Canyon	JC237-044-GC10/	234	22/08/2022	14:19:00	48 33.7072	9 55.9170	1879.0										42 cm recovered - loose muddy sand overlying very stiff muddy sand.	NOCS - MG
Whittard Canyon	JC237-045-CTD017/	234	22/08/2022	18:34:00	48 24.7740	9 49.9740	1845.0	1787.0		234	22/08/2022	21:18:00	48 24.7720	9 49.9580	1829.0		Same location as CTD006	UEA
Whittard Canyon	JC237-045-CTD017/SAPS04	234	22/08/2022	19:38:00	48 24.7720	9 49.9580	1845.0	1500.0		234	22/08/2022	20:38:00	48 24.7720	9 49.9610	1500.0		712l filtered	JMUL
Whittard Canyon	JC237-046-ROV392/	234	22/08/2022	21:33:00	48 24.5030	9 49.5238	1548.0			235	23/08/2022	10:02:00	48 24.5770	9 50.1000	1863.0		Rockdrill fitted	
Whittard Canyon	JC237-046-ROV392/DRL01	234	22/08/2022	23:49:00	48 24.6098	9 49.5138	1590.0	1590.0		235	23/08/2022	00:35:00					white carbonate with black surface	BGS
Whittard Canyon	JC237-046-ROV392/BIOB01	235	23/08/2022	02:00:00	48 24.6053	9 49.5892	1616.0	1616.0									white sponge	NOCS
Whittard Canyon	JC237-046-ROV392/BIOB02	235	23/08/2022	02:05:00	48 24.6063	9 49.5918	1616.0	1616.0									red soft coral	NOCS
Whittard Canyon	JC237-046-ROV392/BIOB03	235	23/08/2022	02:09:00	48 24.6053	9 49.5894	1616.0	1616.0									yellow soft coral	NOCS
Whittard Canyon	JC237-046-ROV392/BIOB04	235	23/08/2022	02:21:00	48 24.6078	9 49.5913	1616.0	1616.0									Lophelia	NOCS
Whittard Canyon	JC237-046-ROV392/NSK01	235	23/08/2022	02:26:40	48 24.6073	9 49.5894	1616.0	1616.0									Large Niskin in sponge field - did NOT fire	NOCS - OTE
Whittard Canyon	JC237-046-ROV392/DRL02	235	23/08/2022	04:48:19	48 24.4603	9 49.5057	1631.3	1631.3									stuck in drill barrel	BGS
Whittard Canyon	JC237-046-ROV392/RCK01	235	23/08/2022	06:49:00	48 24.5160	9 49.9880	1917.0	1917.0									Hand sample - black rock rounded	BGS
Whittard Canyon	JC237-046-ROV392/RCK02	235	23/08/2022	07:09:00	48 24.5210	9 49.9970	1908.0	1908.0									light rock/concrete - fishing weight?	BGS
Whittard Canyon	JC237-046-ROV392/RCK03	235	23/08/2022	07:15:00	48 24.5200	9 49.9960	1908.0	1908.0									soft white rock	BGS
Whittard Canyon	JC237-046-ROV392/NSK02	235	23/08/2022	07:58:00	48 24.5960	9 50.2650	1827.0	1827.0									all 6 fired - control values, featureless	NOCS - OTE
Whittard Canyon	JC237-047-CTD018/	235	23/08/2022	13:44:00	48 34.2700	9 56.1108	1850.0	1867.0		235	23/08/2022	15:15:00	48 34.2723	9 56.1108	1852.0			
Whittard Canyon	JC237-048-ROV393/	235	23/08/2022	18:35:00	48 45.6951	10 27.5600	745.0			236	24/08/2022	09:45:00	48 45.5739	10 27.6979	645.0		MBES Reson 7125 survey of Wall	
Whittard Canyon	JC237-048-ROV393/NSK01	236	24/08/2022	08:09:00	48 45.5051	10 27.5907	649.0	649.0									6x small niskins	
Whittard Canyon	JC237-048-ROV393/TBE01	236	24/08/2022	08:31:00	48 45.5020	10 27.5988	648.0	648.0									cwc (maybe Desmophyllum)	USoton
Whittard Canyon	JC237-048-ROV393/TBE02	236	24/08/2022	08:45:00	48 45.5042	10 27.6006	645.5	645.5									cwc (maybe Desmophyllum)	USoton
Whittard Canyon	JC237-049-AUV41/	236	24/08/2022	13:26:06	48 24.9739	9 40.8481	382.0			236	24/08/2022	17:19:45	48 23.1452	9 44.5412	361.0		Dropped abort weight on touching seafloor	
Whittard Canyon	JC237-050-ROV394/	236	24/08/2022	18:28:28	48 20.6774	9 39.0102	1091.0			237	24/08/2022	08:41:00	48 19.6360	9 38.4150	441.0			
Whittard Canyon	JC237-050-ROV394/PSH01	236	24/08/2022	20:24:00	48 20.5962	9 39.0046	1107.7	1107.7									SEDS + Plastic	NOCS - MG
Whittard Canyon	JC237-050-ROV394/PSH02	236	24/08/2022	20:27:00	48 20.5962	9 39.0046	1107.7	1107.7									OrgC + eDNA	NOCS - MG
Whittard Canyon	JC237-050-ROV394/SLP01	236	24/08/2022	21:17:00	48 20.5240	9 39.0171	1083.0	1083.0									Coral Lophelia (good sample)	USoton
Whittard Canyon	JC237-050-ROV394/SLP02	236	24/08/2022	21:30:00	48 20.5248	9 39.0161	1083.0	1083.0									Coral sample Lophelia (very small sample)	USoton
Whittard Canyon	JC237-050-ROV394/SLP03	236	24/08/2022	22:03:00	48 20.5250	9 39.0160	1083.0	1083.0									Coral sample Lophelia (small sample)	USoton
Whittard Canyon	JC237-050-ROV394/PSH03	236	24/08/2022	23:18:00	48 20.3480	9 39.0280	986.9	986.9									SEDS	NOCS - MG
Whittard Canyon	JC237-050-ROV394/PSH04	236	24/08/2022	23:19:00	48 20.3480	9 39.0280	986.9	986.9									OrgC	NOCS - MG
Whittard Canyon	JC237-050-ROV394/SLP04	237	25/08/2022	00:16:00	48 20.3010	9 39.0610	969.5	969.5									Coral sample Lophelia (several >3 pieces)	USoton
Whittard Canyon	JC237-050-ROV394/SLP05	237	25/08/2022	00:23:00	48 20.3010	9 39.0630	969.6	969.6									Coral sample Lophelia	USoton
Whittard Canyon	JC237-050-ROV394/RCK01	237	25/08/2022	02:22:00	48 20.1630	9 38.9910	813.7	813.7									White rock on terrace	OGS/BGS
Whittard Canyon	JC237-050-ROV394/RCK02	237	25/08/2022	03:23:00	48 20.0450	9 38.8650	652.5	652.5									2 rocks taken in 1 claw, 1 brown, 1 black	OGS/BGS
Whittard Canyon	JC237-050-ROV394/RCK03	237	25/08/2022	03:27:00	48 20.0440	9 38.8640	651.8	651.8									Square chunk of black rock	OGS/BGS
Whittard Canyon	JC237-050-ROV394/PSH05	237	25/08/2022	04:17:00	48 19.9870	9 38.7700	632.9	632.9									1/3 full, refusal at that depth. Sand over stiff clay. SEDS + Plastic	NOCS - MG
Whittard Canyon	JC237-050-ROV394/PSH06	237	25/08/2022	04:22:00	48 19.9880	9 38.7700	632.7	632.7									~1/2 full, refusal at that depth, sand over stiff clay. OrgC/eDNA	NOCS - MG
Whittard Canyon	JC237-050-ROV394/PSH07	237	25/08/2022	06:59:00	48 19.5710	9 38.6090	465.2	465.2									Core dropped, may have impacted the surface. SEDS	NOCS - MG
Whittard Canyon	JC237-050-ROV394/PSH08	237	25/08/2022	07:14:00	48 19.5680	9 38.6050	464.3	464.3									h1/2 full. OrgC/eDNA	NOCS - MG
Transit	JC237-051-CPR02/	237	25/08/2022	08:45:00	48 19.6657	9 38.3903	467.0			238	26/08/2022	12:03:00	48 50.2700	16 27.2200	4780.0			
PAP	JC237-052-CTD019/	238	26/08/2022	12:26:00	48 50.5380	16 30.2690	4810.0	4000.0		238	26/08/2022	15:12:00	48 50.5000	16 30.1960	4807.0			
PAP	JC237-053-AUV42/	238	26/08/2022	15:37:00	48 50.9963	16 32.1150	4911.0			239	27/08/2022	14:56:00	48 53.5707	16 31.4448	4836.0			
PAP	JC237-054-ROV395/	238	26/08/2022	19:26:41	48 51.4215	16 36.7630	4806.0			239	27/08/2022	12:55:17	48 50.8136	16 35.8190	4807.0			
PAP	JC237-054-ROV395/PSH01	239	27/08/2022	00:23:00	48 51.2250	16 36.4890	4842.5	4842.5									pushcore in trawl mark	NOCS
PAP	JC237-054-ROV395/PSH02	239	27/08/2022	00:35:00	48 51.2170	16 36.4670	4842.5	4842.5									pushcore in background	NOCS
PAP	JC237-054-ROV395/PSH03	239	27/08/2022	01:57:00	48 51.1260	16 36.3080	4843.0	4843.0									pushcore in trawl mark	NOCS
PAP	JC237-054-ROV395/PSH04	239	27/08/2022	02:00:00	48 51.1200	16 36.3510	4843.0	4843.0									pushcore in trawl mark	NOCS
PAP	JC237-054-ROV395/PSH05	239	27/08/2022	02:09:00	48 51.1230	16 36.3210	4843.1	4843.1									pushcore outside trawl mark	NOCS

Site	Final sample number	JDay	Start Date	Start Time GMT	Start Lat Deg	Start Lat Min N	Start Long Degr W	Start Long Min W	Start Waterdept h meter	Equipm ent depth	Jday End	End Date	End Time GMT	End Lat Degr	End Lat Min	End Lon Deg	End Lon Min	End Long eph (m)	Comments	Recipient
PAP	JC237-054-ROV395/PSH06	239	27/08/2022	02:12:00	48	51.1300	16	36.3296	4843.2	4843.2									pushcore outside trawl mark	NOCS
PAP	JC237-054-ROV395/SLP01	239	27/08/2022	02:52:45	48	51.1280	16	36.2507	4843.4	4843.4									slurp collection of polychaetes in trawl/epibenthic sledge OGS/BGSRas	NOCS
PAP	JC237-054-ROV395/SLP02	239	27/08/2022	04:41:00	48	50.9798	16	36.1218	4843.5	4843.5									young fairy ring sample, slight problems when sampling	NOCS
PAP	JC237-054-ROV395/PSH07	239	27/08/2022	05:29:00	48	50.9457	16	36.0805	4843.3	4843.3									cone beast, pushcore	NOCS
PAP	JC237-054-ROV395/PSH08	239	27/08/2022	05:54:00	48	50.9333	16	36.0592	4843.2	4843.2									probably coral, pushcore	NOCS
PAP	JC237-054-ROV395/PSH09	239	27/08/2022	06:34:00	48	50.9015	16	36.0244	4843.1	4843.1									cerianthid	NOCS
PAP	JC237-054-ROV395/PSH10	239	27/08/2022	06:38:00	48	50.9025	16	36.0303	4842.9	4842.9									cerianthid (larger, darker)	NOCS
PAP	JC237-054-ROV395/NSK01	239	27/08/2022	06:56:00	48	50.8633	16	35.9813	4841.9	4841.9									small niskins (all 6)	NOCS - OTE
PAP	JC237-054-ROV395/TBE01	239	27/08/2022	07:26:00	48	50.8150	16	35.9310	4842.7	4842.7									stick-like object	NOCS
PAP	JC237-054-ROV395/PSH11	239	27/08/2022	07:55:00	48	50.7920	16	35.8961	4842.0	4842.0									pushcore on anemone	NOCS
PAP	JC237-054-ROV395/TBE02	239	27/08/2022	08:08:00	48	50.7954	16	35.8964	4842.0	4842.0									anemone?	NOCS
PAP	JC237-054-ROV395/TBE03	239	27/08/2022	08:16:00	48	50.7696	16	35.8753	4842.0	4842.0									anemone and sponge	NOCS
PAP	JC237-054-ROV395/TBE04	239	27/08/2022	08:50:00	48	50.7570	16	35.8384	4842.0	4842.0									amperima x 2	NOCS
PAP	JC237-054-ROV395/NSK02	239	27/08/2022	09:16:00	48	50.7428	16	35.8224	4839.0	4839.0									big niskin fired	NOCS - OTE
PAP	JC237-055-ROV396/	239	27/08/2022	17:17:21	48	56.0053	16	32.1705	4807.0		240	28/08/2022	13:14:00	48	57.4050	16	32.7244	4807.0		
PAP	JC237-055-ROV396/SLP01	239	27/08/2022	23:41:00	48	56.0770	16	32.1860	4837.0	4837.0									Daontesia porcupina Attached to 'golf-ball'	
PAP	JC237-055-ROV396/SLP02	239	27/08/2022	00:03:00	48	56.0830	16	32.1850	4837.0	4837.0									sized piece of rock	NOCS
PAP	JC237-055-ROV396/SLP03	240	28/08/2022	00:03:00	48	56.0800	16	32.1840	4837.0	4837.0									Daontesia porcupina	NOCS
PAP	JC237-055-ROV396/PSH01	240	28/08/2022	00:30:00	48	56.1029	16	32.1985	4837.2	4837.2									Cerianthid anemone, probably liquidised	NOCS
PAP	JC237-055-ROV396/PSH02	240	28/08/2022	00:49:00	48	56.1383	16	32.2350	4836.4	4836.4									cerianthid anemone	NOCS
PAP	JC237-055-ROV396/TBE01	240	28/08/2022	01:05:00	48	56.1420	16	32.2440	4836.0	4836.0									cerianthid anemone	NOCS
PAP	JC237-055-ROV396/NSK01	240	28/08/2022	05:49:00	48	56.8990	16	33.2960	4746.0	4746.0									<i>Amphianthus bathybiium</i>	NOCS
PAP	JC237-055-ROV396/NSK02	240	28/08/2022	08:39:00	48	57.3100	16	32.6470	4633.0	4633.0									all 6 small niskins fired	NOCS - OTE
PAP	JC237-055-ROV396/TBE02	240	28/08/2022	09:13:00	48	57.3600	16	32.6860	4630.0	4630.0									large niskin on top of abyssal hill	NOCS - OTE
PAP	JC237-055-ROV396/BIOB01	240	28/08/2022	09:35:00	48	57.3600	16	32.6885	4629.0	4629.0									sea cucumber	NOCS
PAP	JC237-055-ROV396/PSH03	240	28/08/2022	09:48:00	48	57.3644	16	32.6926	4629.0	4629.0									large sea cucumber	NOCS
PAP	JC237-055-ROV396/PSH04	240	28/08/2022	09:56:00	48	57.6990	16	32.6915	4629.0	4629.0									actinauge	NOCS
PAP	JC237-055-ROV396/PSH05	240	28/08/2022	10:09:00	48	57.3800	16	32.6980	4629.0	4629.0									actinauge anemone	NOCS
PAP	JC237-056-AUV43/	240	28/08/2022	15:57:00	48	41.9170	16	24.2000			241	29/08/2022	16:29:00	48	40.8533	16	24.0219	4833.0		
PAP	JC237-057-ROV397/	240	28/08/2022	19:59:00	48	43.5015	16	21.8661	4807.0		241	29/08/2022	11:27:00	48	43.7236	16	22.8905	4807.0		
PAP	JC237-057-ROV397/TBE01	240	28/08/2022	23:41:00	48	43.5150	16	21.8990	4839.0	4839.0									Amperima - like holo, damaged?	NOCS
PAP	JC237-057-ROV397/TBE02	240	28/08/2022	23:49:00	48	43.5150	16	21.8990	4839.0	4839.0									Amperima - 3 more	NOCS
PAP	JC237-057-ROV397/TBE03	240	28/08/2022	23:57:00	48	43.5150	16	21.8990	4839.0	4839.0									another amperima	NOCS
PAP	JC237-057-ROV397/PSH01	241	29/08/2022	00:01:00	48	43.5150	16	21.8990	4839.0	4839.0									background sed core	NOCS
PAP	JC237-057-ROV397/PSH02	241	29/08/2022	00:03:00	48	43.5150	16	21.8990	4839.0	4839.0									background sed core	NOCS
PAP	JC237-057-ROV397/PSH03	241	29/08/2022	00:25:00	48	43.5150	16	21.8990	4839.0	4839.0									pushcore to sample 1 vagabunda	NOCS
PAP	JC237-057-ROV397/TBE04	241	29/08/2022	01:47:00	48	43.5682	16	22.0505	4840.0	4840.0									Stalked tunicate species	NOCS
PAP	JC237-057-ROV397/TBE05	241	29/08/2022	02:09:00	48	43.5630	16	22.0578	4840.0	4840.0									Sponge periferia sp 2	NOCS
PAP	JC237-057-ROV397/PSH04	241	29/08/2022	03:00:00	48	43.5710	16	22.1730	4840.8	4840.8									octacnemus by pushore	NOCS
PAP	JC237-057-ROV397/PSH05	241	29/08/2022	03:35:00	48	43.6023	16	22.2874	4840.9	4840.9									background sed core	NOCS
PAP	JC237-057-ROV397/PSH06	241	29/08/2022	03:37:00	48	43.6000	16	22.2824	4841.0	4841.0									background sed core	NOCS
PAP	JC237-057-ROV397/PSH07	241	29/08/2022	03:59:00	48	43.5976	16	22.3446	4841.0	4841.0									The OGS/BGSIeractinian	NOCS
PAP	JC237-057-ROV397/PSH08	241	29/08/2022	04:26:00	48	43.6040	16	22.3700	4841.0	4841.0									octacnemus - type	NOCS
PAP	JC237-057-ROV397/PSH09	241	29/08/2022	05:07:00	48	43.6470	16	22.5440	4841.0	4841.0									background sed core	NOCS
PAP	JC237-057-ROV397/PSH10	241	29/08/2022	05:11:00	48	43.6370	16	22.5340	4841.0	4841.0									background sed core	NOCS
PAP	JC237-057-ROV397/NSK01	241	29/08/2022	05:29/05:	48	43.6690	16	22.6170	4840.0	4840.0									small niskin	NOCS - OTE
PAP	JC237-057-ROV397/TBE06	241	29/08/2022	06:06:00	48	43.6890	16	22.6520	4841.0	4841.0									2 x amperima + 1 + 1	NOCS
PAP	JC237-057-ROV397/PSH11	241	29/08/2022	07:50:00	48	43.7150	16	22.8470	4841.0	4841.0									background sed core	NOCS
PAP	JC237-057-ROV397/PSH12	241	29/08/2022	07:03:00	48	43.7300	16	22.8460	4841.0	4841.0									background sed core	NOCS
PAP	JC237-057-ROV397/PSH13	241	29/08/2022	07:25:00	48	43.7170	16	22.8470	4841.0	4841.0									stalked crinoid	NOCS
PAP	JC237-057-ROV397/TBE07	241	29/08/2022	07:46:00	48	43.7330	16	22.8740	4840.0	4840.0									anemone on tube	NOCS
PAP	JC237-057-ROV397/TBE08	241	29/08/2022	08:13:00	48	43.7430	16	22.9090	4840.0	4840.0									anemone on stick + brittle star	NOCS
PAP	JC237-057-ROV397/NSK02	241	29/08/2022	08:28:00	48	43.7380	16	22.9110	4840.0	4840.0									large NSK fired	NOCS - OTE
Transit	JC237-058-CP03/	241	29/08/2022	16:35:00	48	40.8200	16	23.9700			242	30/08/2022	17:15:00	48	23.2806	10	5.1682	2763.0		

Site	Final sample number	JDay Start	Start Date	Start Time GMT	Start	Start	Start	Start	Equipm ent	End Time GMT	End Lat Degr	End Lat Min	End Lon Deg	End Lon Min	End waterd ePTH	Comments	Recipient
					Lat Deg	Lat N	Long Degr	Long Min W									
Whittard Canyon	JC237-059-GC11/	242	30/08/2022	19:05:00	48 21.6510	10 4.3890		3195.0								Coring abandoned during deOGS/BGSent to assist with mayday call.	
Whittard Canyon	JC237-060-CTD020/	243	31/08/2022	10:53:00	48 39.1702	10 2.1208		1402.0	1304.0	243 31/08/2022 13:18:00	48 39.1732	10 2.1138	1402.0		Same location as cast 4 and 15		
Whittard Canyon	JC237-060-CTD020/saps05	243	31/08/2022	11:43:00	48 39.1712	10 2.1165		1402.0	1304.0	243 31/08/2022 12:43:00	48 39.1710	10 2.1167	1404.0				
Whittard Canyon	JC237-061-AUV44/	243	31/08/2022	15:13:00	48 33.9766	9 45.2727		363.0		244 01/08/2022 13:09:00	48 33.2944	9 46.7225	180.0				
Whittard Canyon	JC237-062-GC12/	243	31/08/2022	19:17:00	48 21.6600	10 4.3920		3220.0							125 cm (45 cm muddy sand overlying mud)	NOCS - MG	
Whittard Canyon	JC237-063-MGC05/	243	31/08/2022	23:31:00	48 21.6610	10 4.3910		3208.0									
Whittard Canyon	DY152-000-DeepGlider01/									244 01/09/2022 15:00:00	48 19.1940	10 47.4560	2130.0		Deepglider recovery		
Whittard Canyon	JC237-064-CTD021/	244	01/09/2022	15:16:00	48 19.1950	9 47.4570		2099.0		244 01/09/2022 17:08:00	48 19.1959	9 47.4564	2089.0		Deepglider calibration cast, conductivity 1 fouled near-surface on downcast (~115m)	UEA	
Whittard Canyon	JC237-065-ROV398/	244	01/09/2022	19:13:00	48 22.4812	10 2.6897		3132.0		245 02/09/2022 11:12:10	48 21.5690	10 2.0340	2555.0				
Whittard Canyon	JC237-065-ROV398/PSH01	244	01/09/2022	21:41:00	48 22.5364	10 2.6791		3152.0	3152.0						Full core, Organic matter, blue1	NOCS - MG	
Whittard Canyon	JC237-065-ROV398/PSH02	244	01/09/2022	21:46:00	48 22.5356	10 2.6787		3152.0	3152.0						seeds, green1	NOCS - MG	
Whittard Canyon	JC237-065-ROV398/SLP01	244	01/09/2022	22:05:00	48 22.5311	10 2.6844		3151.0	3151.0						small cucumbers, chamber red2	NOCS	
Whittard Canyon	JC237-065-ROV398/NSK01	244	01/09/2022	22:12:00	48 22.5296	10 2.6786		3151.0	3151.0						small niskins over sea cucumbers	NOCS - OTE	
Whittard Canyon	JC237-065-ROV398/TBE01	244	01/09/2022	22:26:00	48 22.5324	10 2.6789		3151.0	3151.0						small cucumbers into tube 12	NOCS	
Whittard Canyon	JC237-065-ROV398/PSH03	244	01/09/2022	23:30:00	48 22.4225	10 2.5294		3151.0	3151.0						SAPS, Yellow1	NOCS - MG	
Whittard Canyon	JC237-065-ROV398/PSH04	245	02/09/2022	00:16:00	48 22.3551	10 2.4433		3180.0	3180.0						Seds, red1	NOCS - MG	
Whittard Canyon	JC237-065-ROV398/PSH05	245	02/09/2022	00:19:00	48 22.3551	10 2.4433		3189.0	3189.0						organic C, red2	NOCS - MG	
Whittard Canyon	JC237-065-ROV398/PSH06	245	02/09/2022	00:53:00	48 22.2717	10 2.3578		3204.0	3204.0						org C, sandy. If it spills, bag contents of core catcher and keep for seds, yellow2	NOCS - MG	
Whittard Canyon	JC237-065-ROV398/PSH07	245	02/09/2022	00:54:00	48 22.2717	10 2.3578		3204.0	3204.0						overpenetrated, seds, blue 2	NOCS - MG	
Whittard Canyon	JC237-065-ROV398/SLP02	245	02/09/2022	02:17:00	48 22.1528	10 2.2413		3074.0	3074.0						white stalks from wall, yellow 3	NOCS	
Whittard Canyon	JC237-065-ROV398/SLP03	245	02/09/2022	02:25:00	48 22.1497	10 2.2411		3074.0	3074.0						white stalk, tube 1	NOCS	
Whittard Canyon	JC237-065-ROV398/NSK02	245	02/09/2022	03:37:00	48 22.1538	10 2.2267		3038.0	3038.0						large niskin over photogrammetry area	NOCS - OTE	
Whittard Canyon	JC237-065-ROV398/PSH08	245	02/09/2022	04:39:00	48 22.1230	10 2.0780		2995.0	2995.0						full core, seds, green2	NOCS - MG	
Whittard Canyon	JC237-065-ROV398/PSH09	245	02/09/2022	04:42:00	48 22.1230	10 2.0780		2995.0	2995.0						full core, org C, green3	NOCS - MG	
Whittard Canyon	JC237-065-ROV398/PSH10	245	02/09/2022	07:07:00	48 21.7956	10 2.0012		2773.0	2773.0						Good core, seds, blue3	NOCS - MG	
Whittard Canyon	JC237-065-ROV398/PSH11	245	02/09/2022	07:11:00	48 21.7936	10 1.9989		2773.0	2773.0						good core, org C, yellow3	NOCS - MG	
Whittard Canyon	JC237-065-ROV398/PSH12	245	02/09/2022	08:55:00	48 21.5422	10 1.9777		2625.0	2625.0						70%, red3	NOCS - MG	
Whittard Canyon	JC237-066-AUV45/	245	02/09/2022	12:53:00	48 32.8826	9 48.3397		200.0		245 02/09/2022 17:40:00	48 33.9923	9 44.7900	182.0				
Whittard Canyon	JC237-067-MGC06/	245	02/09/2022	21:28:42	48 20.0792	9 57.1522		1430.0	1431.0								
Whittard Canyon	JC237-068-CPR04/	245	02/09/2022	23:42:00	48 21.5644	9 49.0018		1468.0		246 03/09/2022 19:05:00	49 25.9000	5 3.6100	89.0				

10. MAPS

General cruise track:

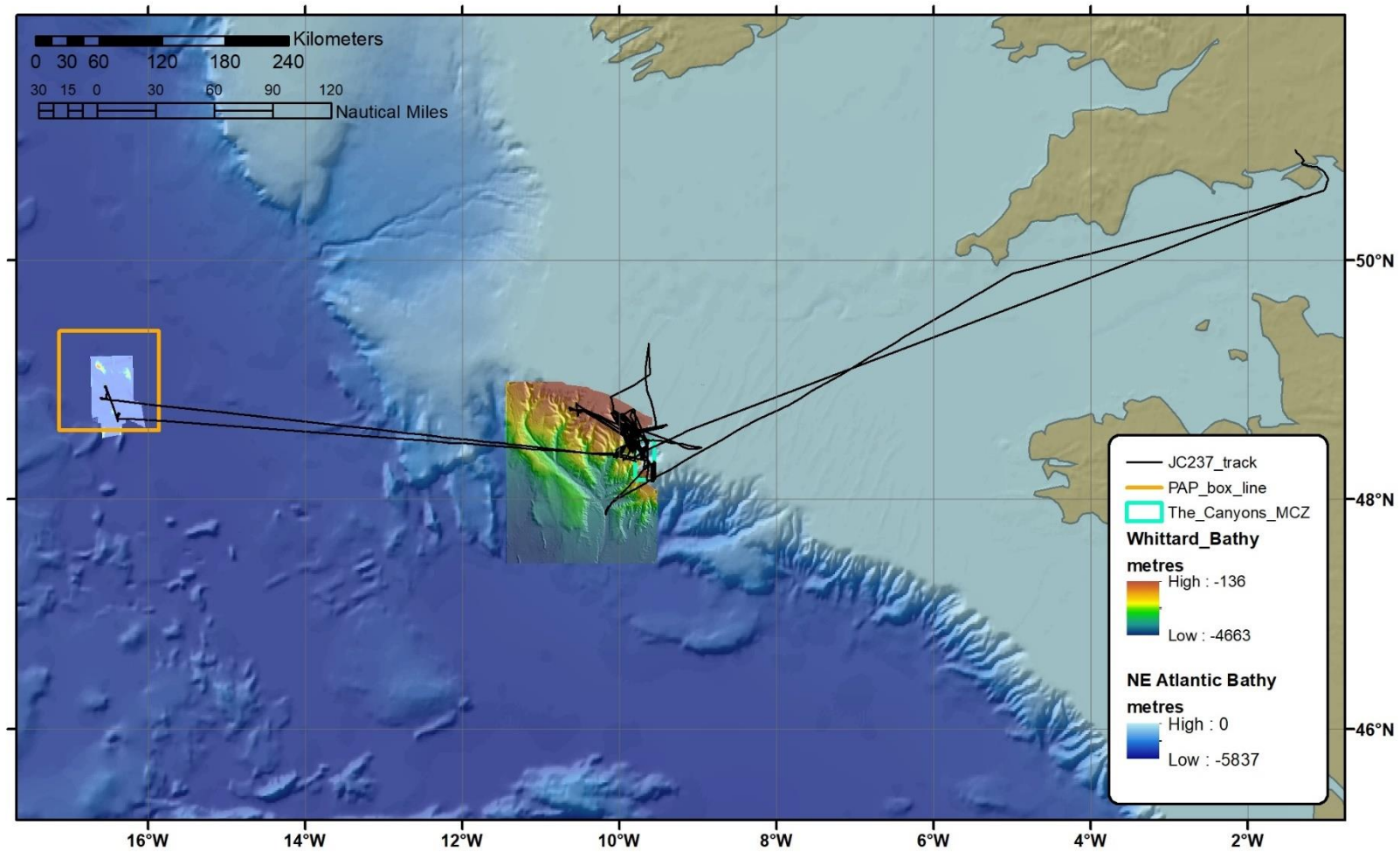

JC237 stations at PAP:

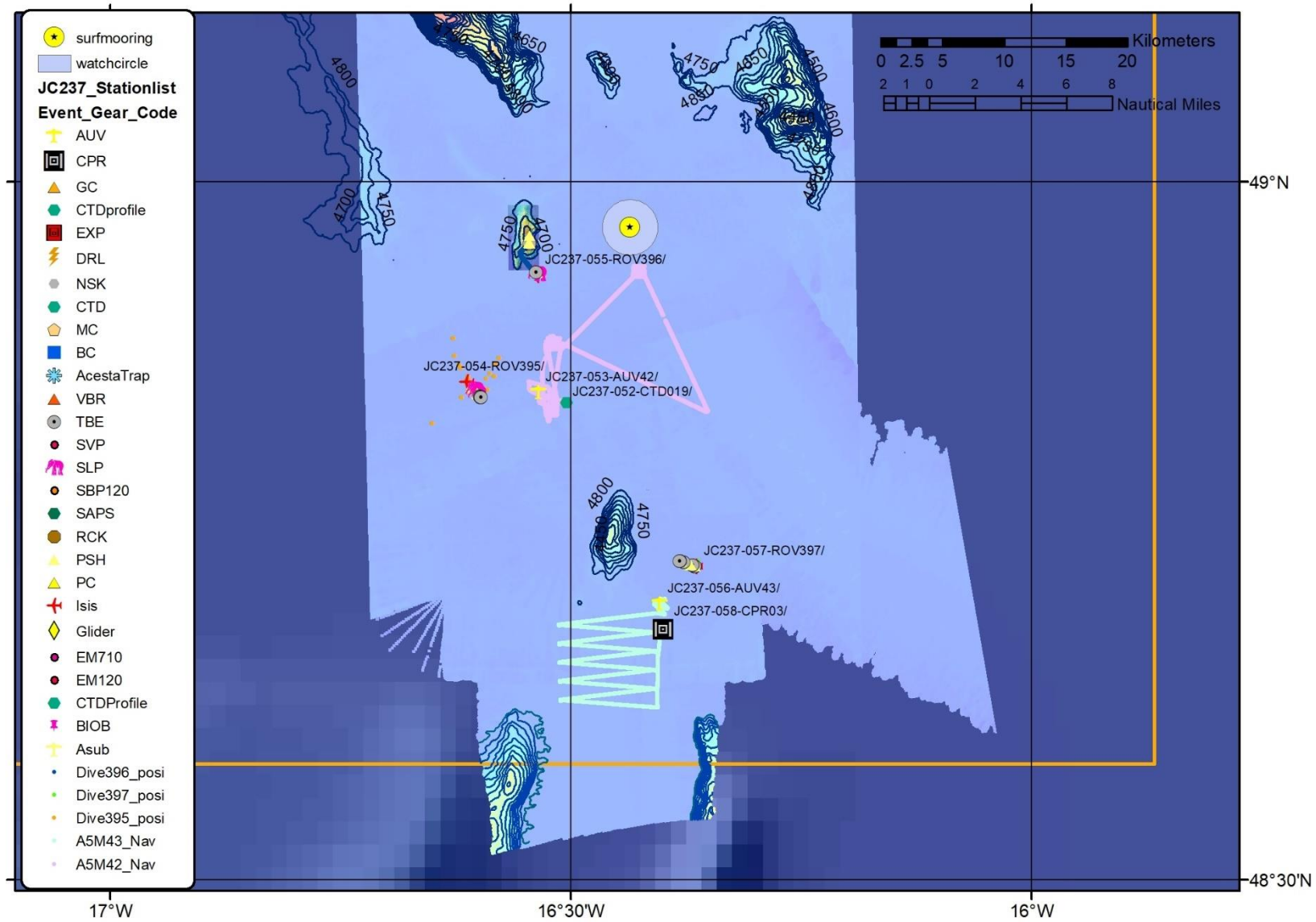

JC237 station locations in Whittard Canyon:

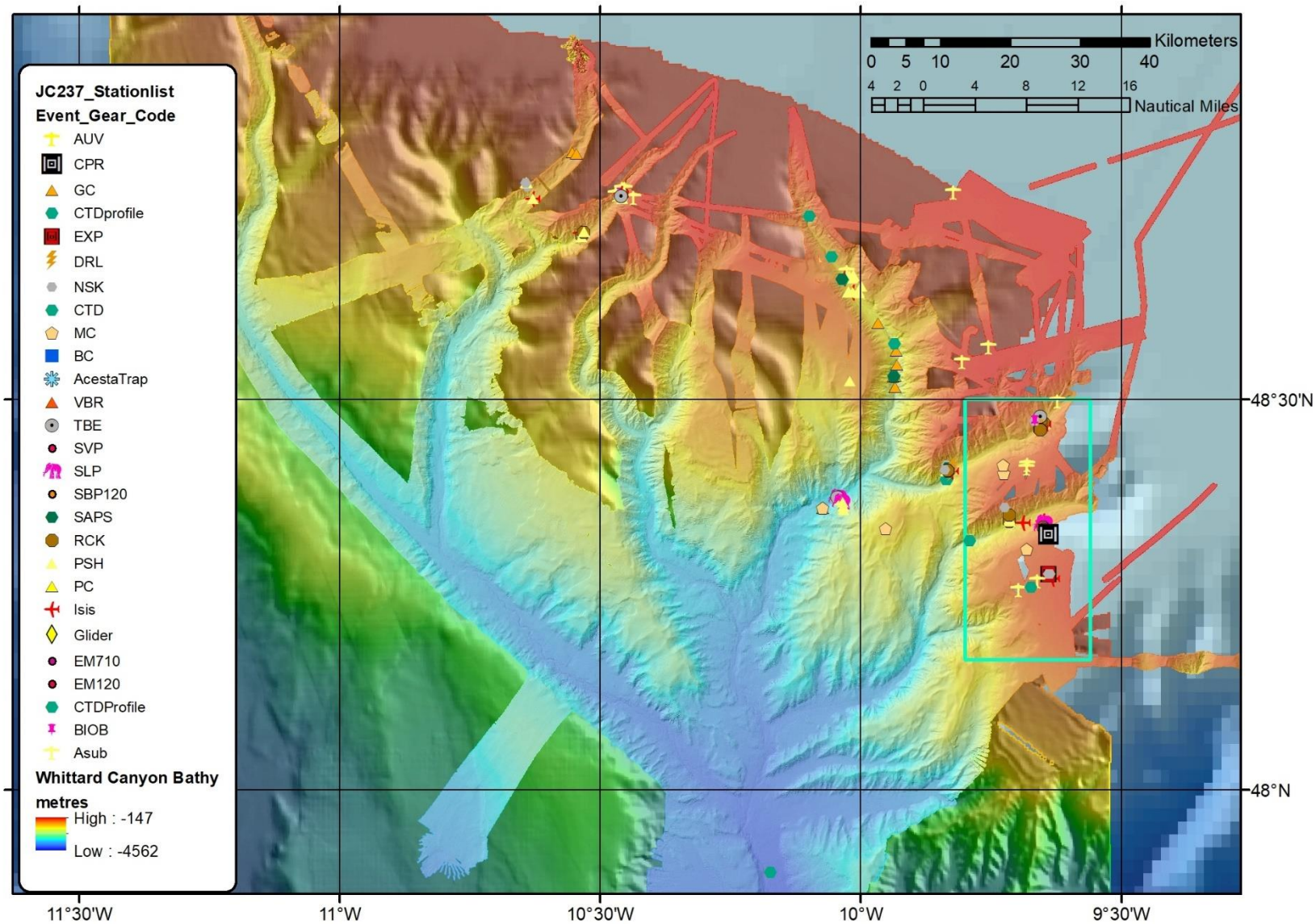

Stations around the Western Middle Branch ('Acesta Wall'):

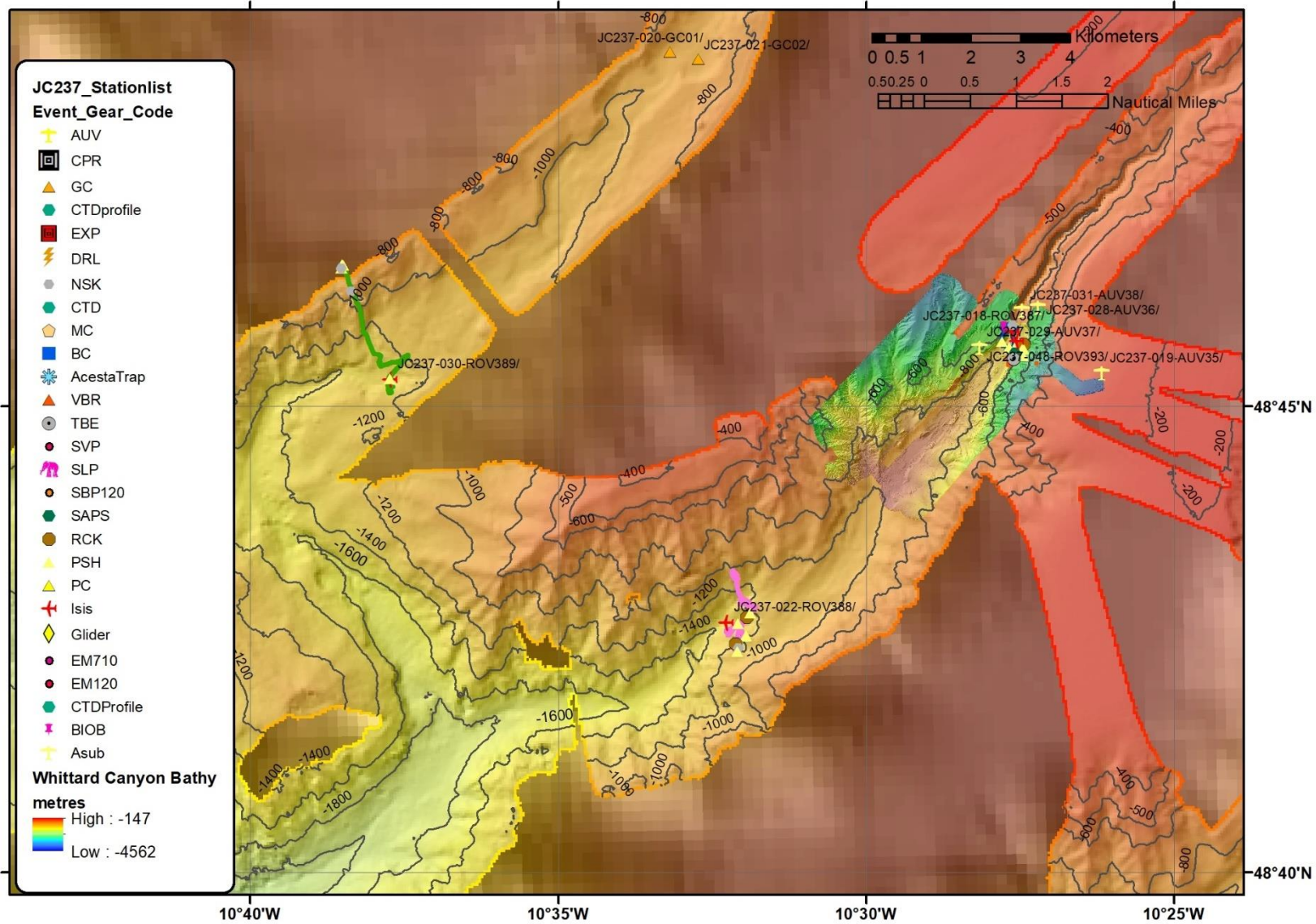

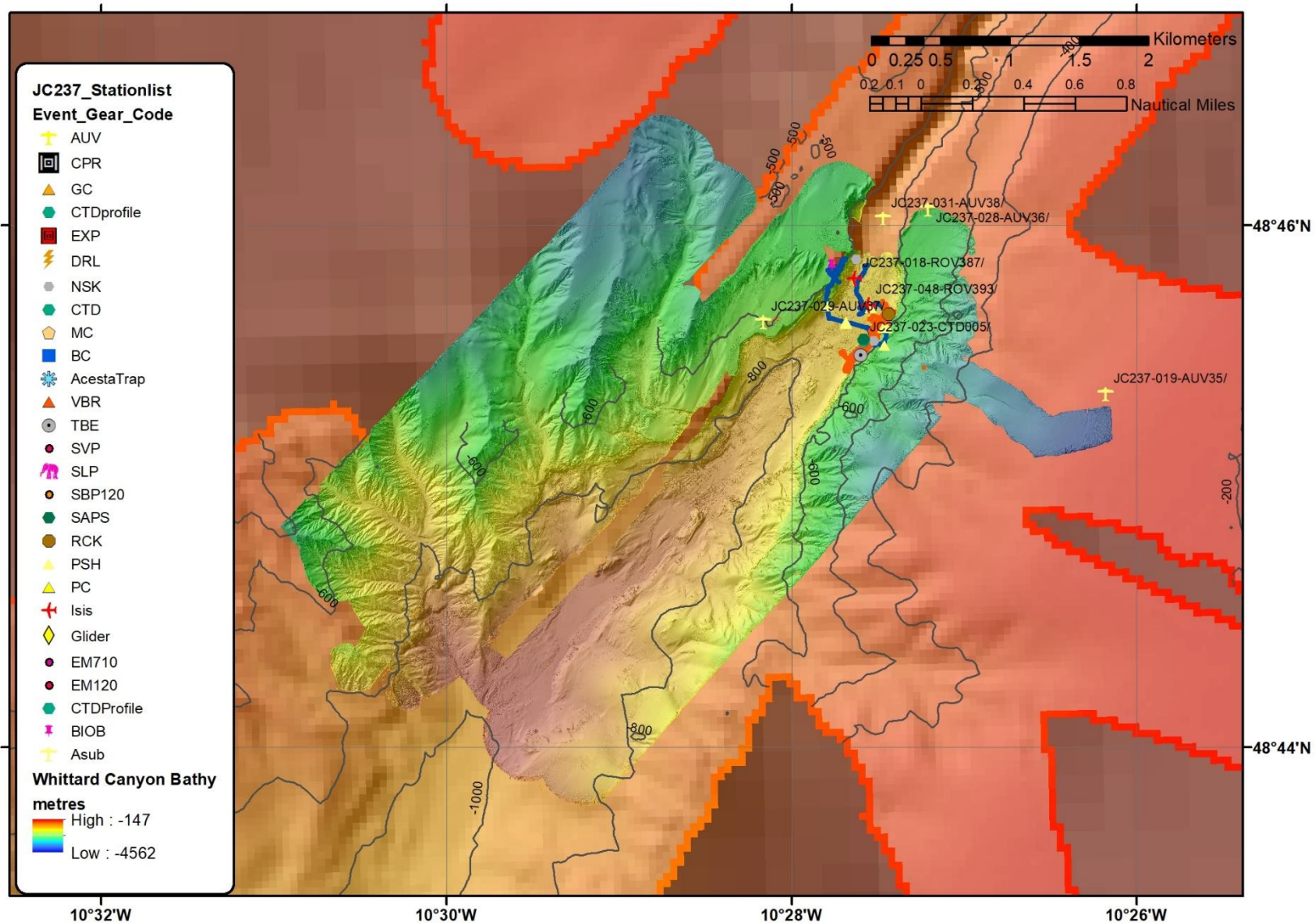

Stations in the Explorer and Dangaard Canyons:

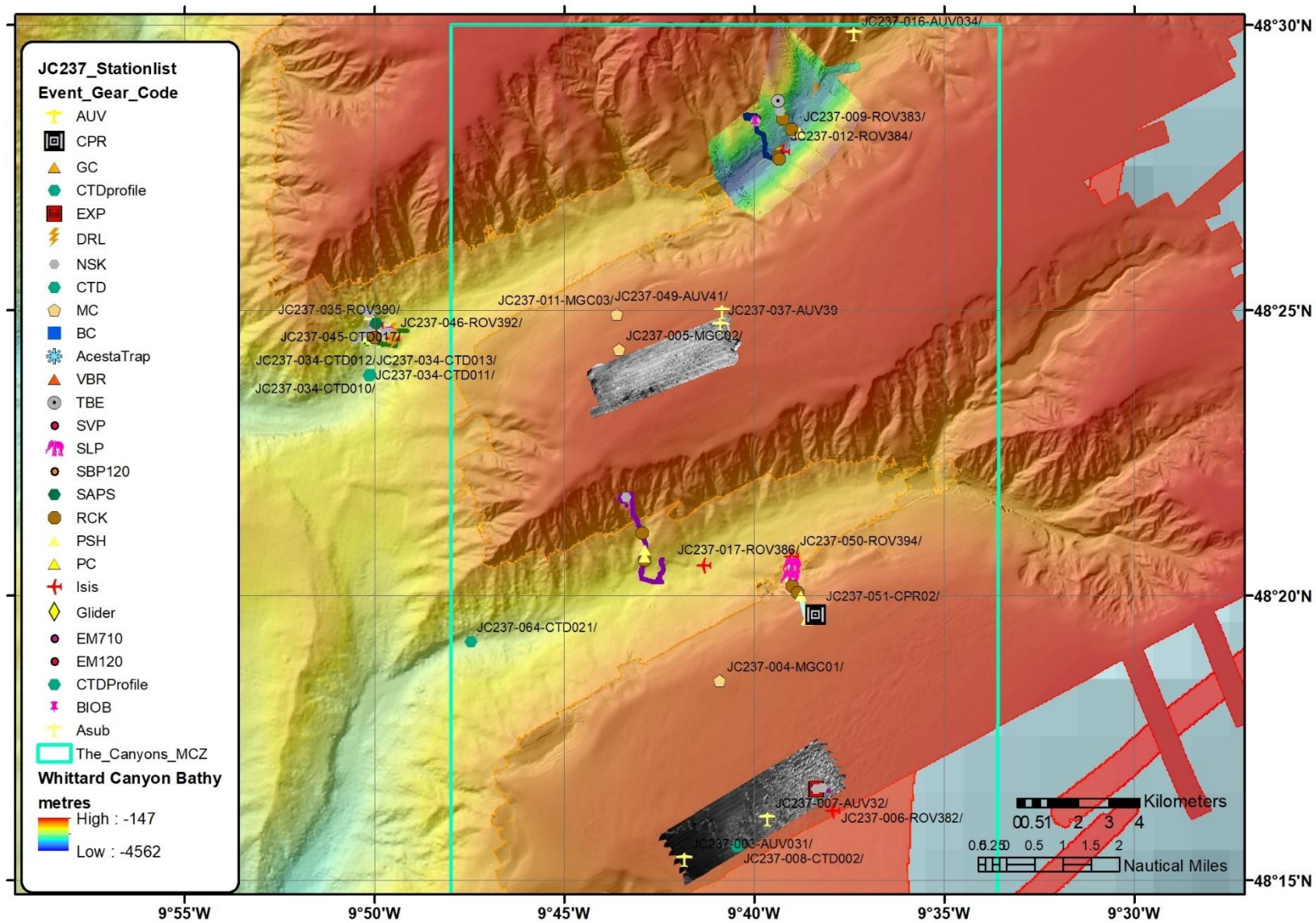

Stations Dangaard Canyon:

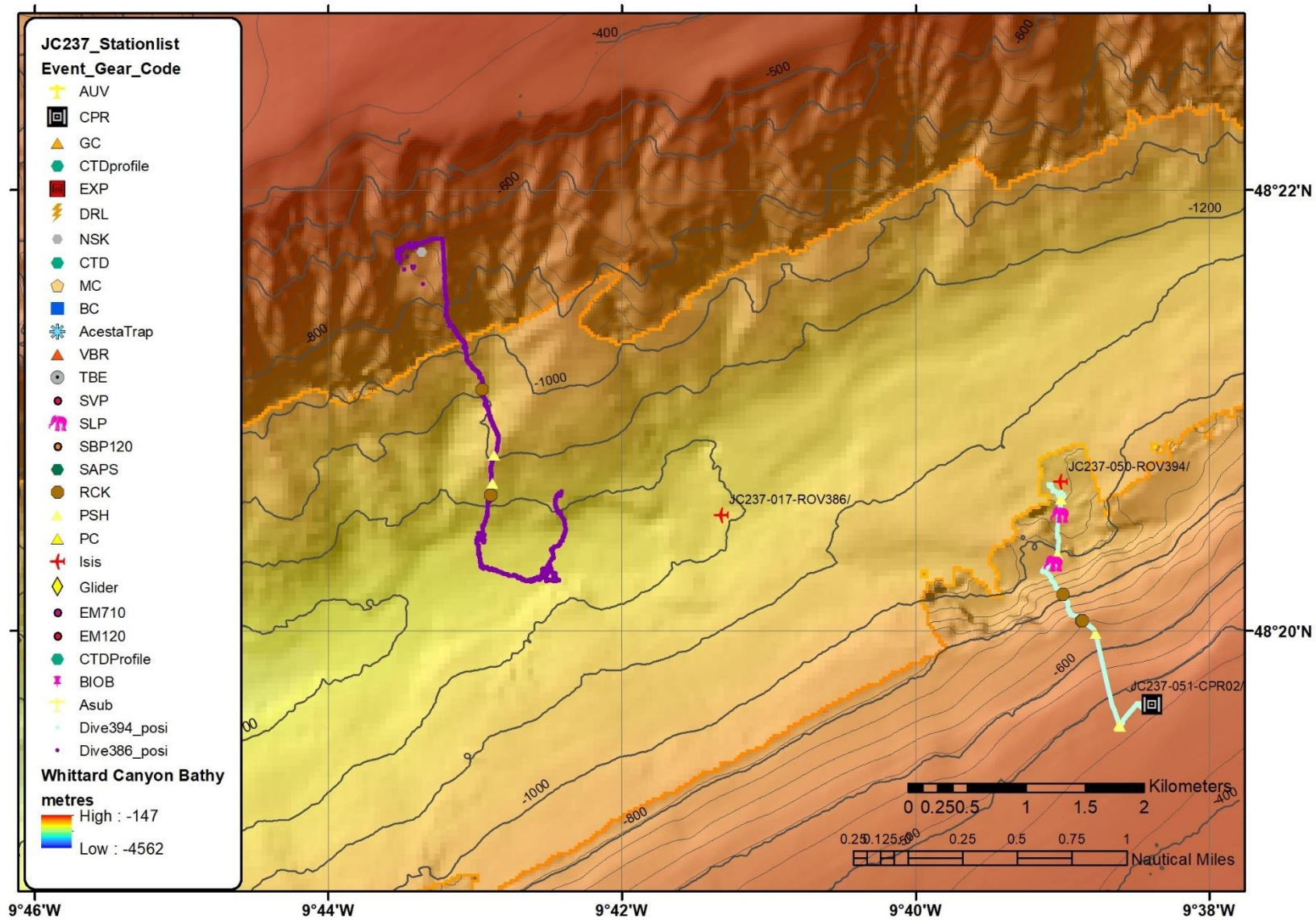

Stations in the Explorer Canyon:

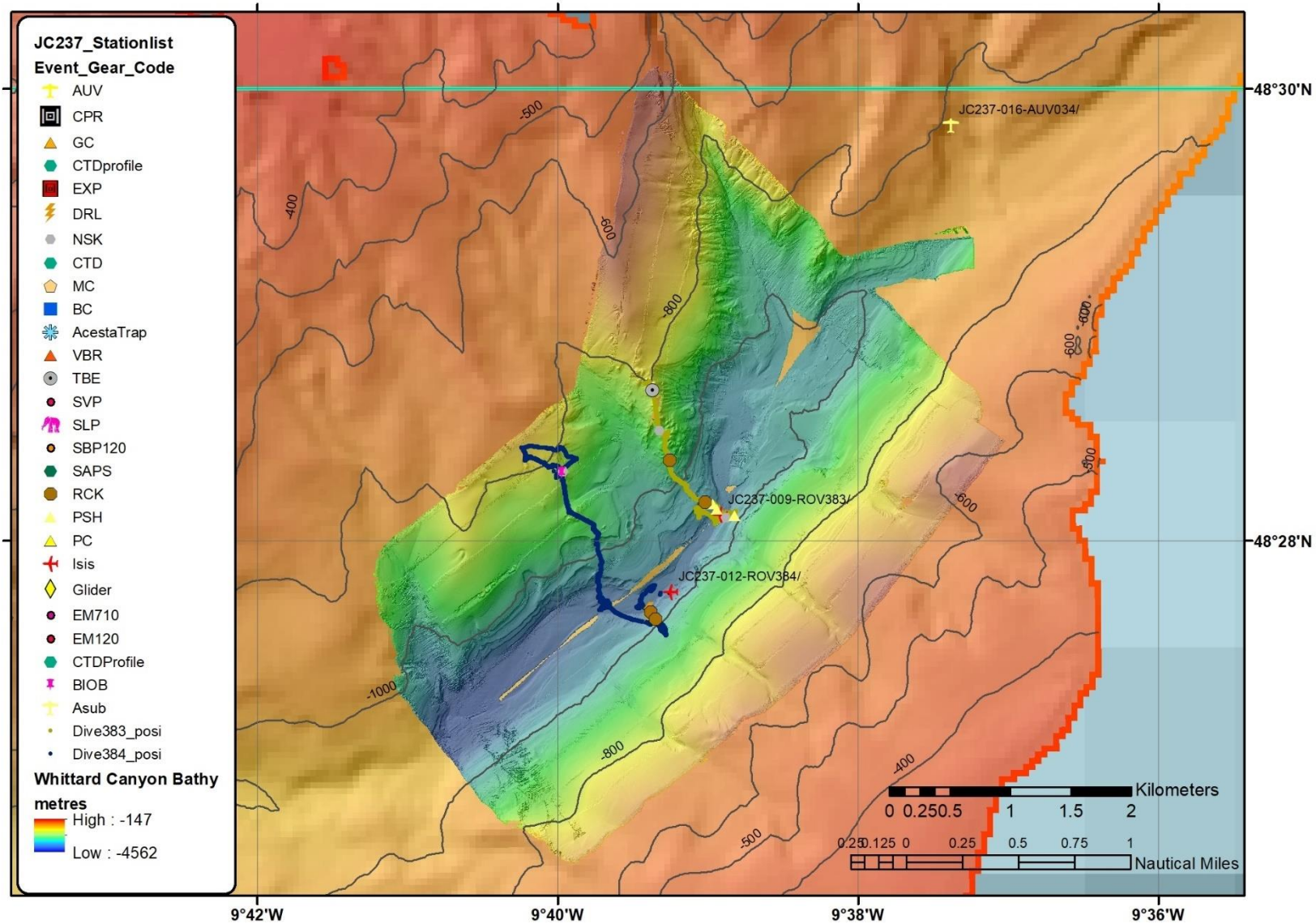

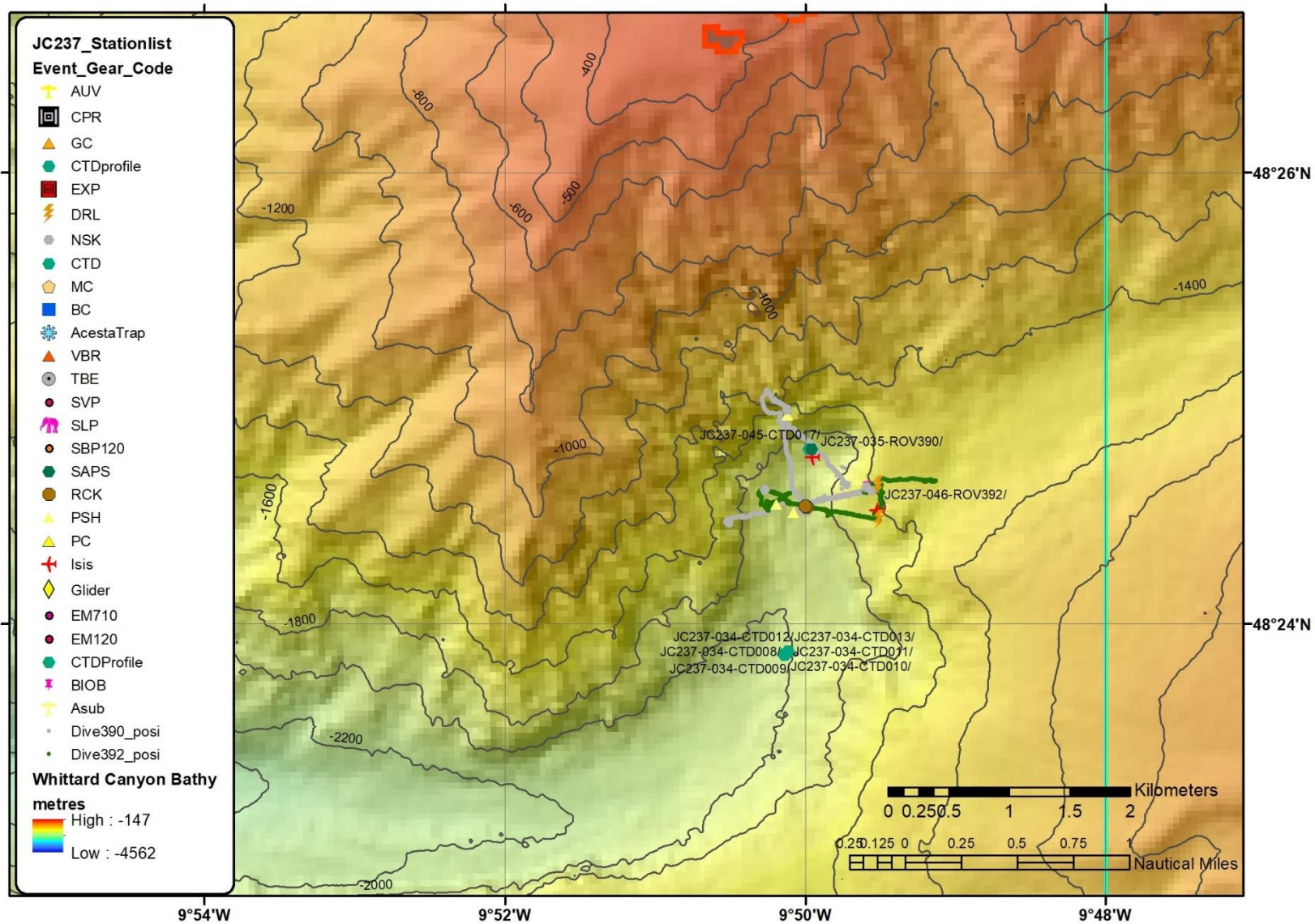

Stations in Eastern Branch:

